

**COLLEGE OF  
ENGINEERING & COMPUTER SCIENCE**



**SECURITY HANDS  
FREE ENTRY SYSTEM**

Senior Design I

Anh Loan Nguyen  
John E. Van Sickle  
Jordan K. Acedera  
Christopher Spalding

**TABLE OF CONTENT**

<b>1.</b>	<b>EXECUTIVE SUMMARY .....</b>	<b>1</b>
1.1	Executive Summary.....	1
<b>2.</b>	<b>PROJECT DESCRIPTION .....</b>	<b>2</b>
2.1	Project Motivation and Goals .....	2
2.2	Objectives.....	3
2.3	Project Requirement and Specifications .....	3
<b>3.</b>	<b>RESEARCH.....</b>	<b>4</b>
3.1	Card Access Control System.....	4
3.1.1	Cards/Tags .....	5
3.1.2	Passive RFID Tag.....	6
3.1.2.1	A Contactless Smart Card.....	6
3.1.2.2	Research Cards .....	7
3.1.2.2.1	iCLASS Prox Card.....	7
3.1.2.2.2	Indala Flexcard.....	7
3.1.2.2.3	ProxCard II .....	8
3.1.3	The Readers .....	8
3.1.4	Reader Controller Interface (RCI) .....	9
3.1.4.1	Wiegand Interface.....	9
3.1.4.2	Clock and Data Mode .....	12
3.1.4.3	RS232 Interface.....	14
3.1.5	Power Supplies.....	14
3.2	Speaker Recognition .....	15
3.2.1	Introduction to Speaker Recognition.....	15
3.2.1.1	Related Devices .....	15

3.2.1.1.1	Images Scientific Instruments (SI) Speech Recognition Circuit SR-07 .....	15
3.2.1.1.2	inVoca Voice-Activated IR Television Remote Control.....	17
3.2.1.1.3	iPhone 4S “Siri” Speech Recognition Application.....	18
<b>3.2.1.2</b>	<b>Speech Recognition .....</b>	<b>19</b>
<b>3.2.1.3</b>	<b>Speaker Recognition Overview .....</b>	<b>19</b>
<b>3.2.1.4</b>	<b>Speaker Identification vs. Speaker Verification .....</b>	<b>19</b>
<b>3.2.1.5</b>	<b>Text-dependent vs. Text-independent .....</b>	<b>20</b>
<b>3.2.2</b>	<b>Methods of Feature Selection.....</b>	<b>21</b>
<b>3.2.2.1</b>	<b>Linear Predictive Coding.....</b>	<b>21</b>
<b>3.2.2.2</b>	<b>Mel Frequency Cepstral Coefficients.....</b>	<b>24</b>
<b>3.2.3</b>	<b>Methods of Pattern Matching.....</b>	<b>27</b>
<b>3.2.3.1</b>	<b>Hidden Markov Models.....</b>	<b>27</b>
3.2.3.1.1	The Babysitter Example .....	27
<b>3.2.3.2</b>	<b>Vector Quantization.....</b>	<b>30</b>
3.2.3.2.1	Basic Definition of Vector Quantization .....	30
3.2.3.2.2	Confidence Rating and Note .....	32
<b>3.2.4</b>	<b>Speaker Recognition Conclusion.....</b>	<b>33</b>
<b>3.3</b>	<b>Door Lock System .....</b>	<b>33</b>
<b>3.3.1</b>	<b>Electronic Access of Doors .....</b>	<b>33</b>
3.3.1.1	Electric Strike & Buzzer.....	33
3.3.1.2	Electric Lock .....	34
3.3.1.3	Magnetic Lock.....	34
<b>3.3.2</b>	<b>Request to Exit Push Button .....</b>	<b>35</b>
<b>3.3.3</b>	<b>Power Supplies and Door Controller .....</b>	<b>35</b>

3.3.4	<b>Contrast of Devices / Vendors of Electronic Security Devices .....</b>	<b>35</b>
3.3.5	<b>Door Hardware .....</b>	<b>38</b>
3.4	<b>PIC Subsystem.....</b>	<b>38</b>
3.4.1	<b>Microcontroller.....</b>	<b>38</b>
3.4.1.1	<b>MSP430G2231 .....</b>	<b>39</b>
3.4.1.2	<b>AVR ATmega8.....</b>	<b>40</b>
3.4.1.3	<b>PIC16F877A .....</b>	<b>41</b>
3.4.2	<b>Compilers and Others Development Tools .....</b>	<b>42</b>
3.4.2.1	<b>CCS PIC Microcontroller C Compiler .....</b>	<b>43</b>
3.4.2.2	<b>Small Device C Compiler.....</b>	<b>43</b>
3.4.2.3	<b>PICKit 2 Microcontroller Programmer .....</b>	<b>44</b>
3.4.2.4	<b>PIC16F877A Development Board .....</b>	<b>44</b>
3.4.3	<b>Printed Circuit Board.....</b>	<b>45</b>
3.4.3.1	<b>Sunstone Circuits .....</b>	<b>45</b>
3.4.3.2	<b>PCBexpress.....</b>	<b>46</b>
3.4.3.3	<b>ExpressPCB .....</b>	<b>46</b>
3.4.3.4	<b>Advanced Circuits .....</b>	<b>47</b>
3.4.4	<b>Communications and Power Supply.....</b>	<b>48</b>
3.4.4.1	<b>Terminal Blocks for Communications .....</b>	<b>48</b>
3.4.4.2	<b>Powered USB .....</b>	<b>49</b>
3.4.4.3	<b>External Power Supply .....</b>	<b>49</b>
3.5	<b>Architectures and Related Diagrams .....</b>	<b>50</b>
3.5.1	<b>Card Access Control Reader Subsystem Diagrams.....</b>	<b>52</b>
3.5.2	<b>Speaker Recognition Diagrams.....</b>	<b>55</b>
3.5.3	<b>Electronic Door Diagrams.....</b>	<b>56</b>

3.5.4	PIC Diagrams .....	58
3.5.4.1	Block Diagram.....	58
3.5.4.2	State Diagram.....	59
3.6	Operation Mode .....	61
4.	PROJECT HARDWARE AND SOFTWARE DESIGN DETAILS.....	63
4.1	Card Reader Subsystem .....	63
4.1.1	125 kHz Long Range Proximity Card Reader 5375 .....	63
4.1.2	ProxCard II.....	65
4.1.3	Reader Converter Interface: OEM Wiegand converter .....	65
4.1.4	Power Supplies .....	67
4.1.5	Installation.....	68
4.2	Speaker Recognition Subsystem .....	68
4.2.1	Texas Instruments MSP430 Ultra Low Power Microcontroller.....	68
4.2.1.1	SoftBaugh ES449 MSP430 Evaluation Board.....	69
4.2.2	Texas Instruments Digital Signal Processors .....	71
4.2.2.1	Texas Instruments C5000 Ultra Low-Power Digital Signal Processors .....	71
4.2.2.2	Texas Instruments TMS320VC5510 DSP Starter Kit (DSK) .....	72
4.2.3	Basic Operation .....	72
4.2.3.1	Interfacing MSP430-F449 Microcontroller with DSP320-C5510 Digital Signal Processor .....	75
4.2.4	Comparison to Images SI Speech Recognition Kit.....	77
4.2.5	Profile Enrollment and Management with Dedicated Netbook .....	78
4.3	Electric Door Latch Subsystem.....	79
4.3.1	Electric Strike.....	79

4.3.2	120V to 12V Transformer.....	80
4.3.3	Strike Timer Module .....	80
4.3.4	Magnetic Contact/ prox switch.....	81
4.3.5	Push to Exit Switch .....	81
4.3.6	Time Module to PIC Integration .....	82
4.3.7	Demonstration Door Frame Assembly.....	82
4.4	PIC Subsystem.....	82
4.4.1	Microchip PIC16F877A .....	82
4.4.1.1	Description of Connection to Power Supply .....	83
4.4.1.2	Description of Connection to Programmer .....	83
4.4.2	Integration with Card Reader Subsystem.....	84
4.4.2.1	Description of Connections .....	84
4.4.2.2	Sequence of Operations.....	84
4.4.3	Integration with Electric Door Latch Subsystem .....	85
4.4.3.1	Description of Connections .....	85
4.4.3.2	Sequence of Operations.....	86
4.4.4	Integration with Speaker Recognition Subsystem .....	86
4.4.4.1	Description of Connections .....	86
4.4.4.2	Sequence of Operation.....	87
4.4.4.3	Additional Plans.....	87
4.4.5	PCB Design .....	87
4.5	Sequence of Operation.....	90
5.	DESIGN SUMMARY OF HARDWARE AND SOFTWARE .....	91
5.1	Hardware Summary .....	91
5.2	Software Summary .....	91

<b>6.</b>	<b>PROJECT PROTOTYPE CONSTRUCTION AND CODING .....</b>	<b>93</b>
<b>6.1</b>	<b>Card Reader Subsystem .....</b>	<b>93</b>
6.1.1	Reader Function .....	93
6.1.2	RS232 Communications.....	93
<b>6.2</b>	<b>Speaker Recognition Subsystem .....</b>	<b>94</b>
6.2.1	Microphone Pre-Amplifier and High-Pass Filter .....	94
<b>6.3</b>	<b>Electric Door Latch Subsystem.....</b>	<b>97</b>
6.3.1	Door Strike Function .....	97
6.3.2	Communications.....	97
<b>6.4</b>	<b>PIC Subsystem.....</b>	<b>97</b>
6.4.1	Programming .....	98
6.4.2	Prototype Circuit.....	98
6.4.3	Construction of the Printed Circuit Board.....	99
<b>7.</b>	<b>PROJECT PROTOTYPE TESTING .....</b>	<b>99</b>
<b>7.1</b>	<b>Card Reader Testing.....</b>	<b>100</b>
7.1.1	Test Environment .....	100
7.1.2	Test Cases and Results.....	101
<b>7.2</b>	<b>Speaker Recognition Testing .....</b>	<b>101</b>
7.2.1	Test Environment .....	101
7.2.2	Test Cases and Results.....	104
<b>7.3</b>	<b>Electric Door Latch Testing .....</b>	<b>104</b>
7.3.1	Test Independent of Other Systems .....	104
7.3.2	Test Environment .....	107
7.3.3	Test Cases and Results.....	107
<b>7.4</b>	<b>PIC Testing.....</b>	<b>107</b>

7.4.1	Test Environment .....	108
7.4.2	Test Cases and Results.....	109
7.5	Total System Testing.....	110
8.	ADMINISTRATIVE CONTENT .....	110
8.1	Project Schedule.....	110
8.2	Budget and Finance Discussion.....	113
8.2.1	Card Access Control Subsystem .....	114
8.2.2	Electronic Door Subsystem .....	115
8.2.3	PIC Microcontroller Subsystem.....	116
8.2.4	Speaker Recognition Subsystem .....	117
8.3	Sponsors .....	118
8.4	Ethical Consideration .....	118
8.5	Project Summary and Conclusion.....	120
9.	APPENDICES .....	I

# 1. EXECUTIVE SUMMARY

## 1.1 Executive Summary

In recent years the problem of home land security has attracted increasing attention and resources. The search for solutions that can guarantee greater independence and a better quality of security has begun to develop easily available state-of-the-art technology. Intelligent control systems, most called smart homes, smart environment systems, intelligent buildings, or intelligent homes can now be planned and would go far towards simplifying the interaction between difference technologies. A great number of benefits would stem from the implementation of such systems: greater safety, autonomy and self-esteem, and consequently, better relationships with others.

The proposed project is to utilize Radio Frequency Identification (RFID) and Voice Recognition technology to create a Security Hands Free Entry System. This project is motivated by the many times when people are hurriedly entering or leaving their residence as they are carrying groceries or boxes which may occupy the use of both hands. With the completion of this project, one will be able to easily enter a home or office even with both hands preoccupied. RFID Technology utilizing a 125 KHz proximity key will allow the user to unlock a lock within two feet (basic) from the door they are trying to open. The users will be able to walk up to the door with their key in their pocket and unlock the door without having to physically touch the key. The proximity key would replace manual keys, swipe cards. The proximity key design will work in combination with voice recognition to ensure a higher level of personal security when unlocking the door. A user spends a few moments enrolling his or her voice in an application (creating a voice profile). Under normal operating conditions when the proximity key is within range, the user will be prompted by the application to speak a predetermined phrase of which will be compared to the voice profile on file. If there's a match, the user is accepted, and the door automatically unlocks. The door will remain unlocked for a pre-programmed period of time, and will return to the locked state at the end of the complete process.

Speaker recognition is one of the most widely used technological advances of our times. The technology has made a large progression to make it practical for commercial consumer use, such as, allowing those with disabilities the freedom to communicate with others. In this project, voice recognition will be manipulated to utilize the capabilities and functionalities of this technology. We plans to achieve this by combining the voice recognition technology with the 125 KHz proximity card access control system.

## 2. PROJECT DESCRIPTION

### 2.1 Project Motivation and Goals

The main motivation behind the security hands free entry system is the core interest of the subject of security from several of the members. Building such a device will develop invaluable skills that can be applied to a wide variety of real life situations. Although this is not a new idea, and has been done in the past, the skills and satisfaction that one gets out of building it yourself, are invaluable. The system has four main components: the Proximity Card Reader system, the Speaker Recognition System, the Electric Door Lock System and the PIC microcontroller. We will use the proximity card reader system, Speaker Recognition System, an electric door locking system and combine all of them with PIC microcontroller acting as central control unit to make up a fully integrated security hands free entry system. In this modern time, maintaining personal security should be considered of the utmost importance. What if we lose the card key, what if someone recorded our voice? With this proposed solution it will take more effort for an adversary to obtain the card key and the voice at the same time.

The security hands free entry system is simple and straightforward. It is designed so that it is self-explanatory in its operation and simple for anyone to use regardless of their educational background even the people that are not as technologically oriented should be able to use the system with much ease. Any technological device should be to facilitate certain aspects of life and not make matters more complicated. The aim of the design team are to gain an in depth understanding of electronic door lock, voice recognition, proximity card reader system integrates with PIC microcontroller in the design and implementation of the Security Hands Free Entry System.

Our primary goal is to design an affordable device for the conveniences. The design has been done in the most efficient way in reference to hardware design. The engineering principles and values are applied throughout the entire design to achieve the best possible solution using the least amount of parts to attain maximum results. All together the system might be costly, but for the target of security and conveniences we have to try to get the best the product we can. If this can be achieved, many other features can be added to our design. The Security Hands Free Entry System should be easy to use, dependable and very accurate. Because of our time constraint, it will be a challenge to add many features to our design.

## 2.2 Objectives

As a part of the design process, the design team needs to have a clear understanding of the task they are trying to accomplish and how to accomplish this task. Furthermore it is vital to be as specific as possible and also give as much details as possible about the requirement of the design. The security hands free entry system shall be comprised of a complete and functioning card access control system, voice recognition and electronic door lock system all into PIC microcontroller as designed.

The card access control system will consist of cards, a reader, and controller (reader converter). A reader is the unit which captures the raw data in the form of cards. The controller will decode the data, to make sure the information correct or not before transfer data to PIC microcontroller which act like an operation interface. From the PIC microcontroller, if the two records match, the person is authenticated for card access control system.

The speaker recognition system requires the user to speak into a microphone. What he/she speaks can be his/her password or an access phrase. Verification time is approximately 5 seconds. To prevent recorded voice use, most speaker recognition devices require the high and low frequencies of the sound to match, which is difficult for many recording instruments to recreate well.

The PIC microcontroller is the central control unit of the security hands free entry system. The speaker system, the card system, and the door lock system shall all inter-connect to the PIC microcontroller for door instructions programmed. Once the PIC microcontroller has verified the data from the card and the profile voice, the match should result in the access being granted. Additionally if the time is within the authorized period for entry, the device will signal and release the electric door lock. Otherwise access will be denied.

## 2.3 Project Requirement and Specifications

The following requirements and specifications are the guiding constraints that we consider when designing every sub-system. The conditions listed below are all physically possible in terms of current technologies and are within the capacity of a focused engineering undergrad. These requirements are discussed in further detail in the succeeding sections.

The Security Hands Free Entry System has four main components: Card Reader Subsystem, the Speaker Recognition Subsystem, the Electrified Door Subsystem and PIC microcontroller. The Card Reader system which included a reader, a reader converter and RFID tags needed a 12VDC or 24VDC power supply. The

Speaker Recognition System which used a DSP chip needed 3V – 3.3V to power it. The Electronic Lock System included a electric strike, request to exit switch, door status switch and a control board. The Electronic lock needs 12VAC power supply. The PIC microcontroller which used microcontroller chip needed 5V to power it up.

As students, we lack much of the hands on experience and real world skills that would enable an engineer to pick the right part for the job. This project represents a significant investment in the development of those “real world” skills. As we research the parts required for the design, we have gained an understanding if the part is going to work for what we are trying to do, but there are always may be unforeseen circumstances that may render that part unusable for the application.

### **3. RESEARCH**

There is a great amount of research that must be done in order to complete our project in the allotted time. The research is important in bridging our knowledge and skills of Computer and Electrical Engineering with the current state of technology. It is mainly through research that engineers gain insight into current market developments and possible solutions to any given problem.

The research done for this project, involved a wide range of items and disciplines, such as research on microcontroller, radio frequency, transceiver, receivers, power supplies specifications design. These are just the items that we needed for our initial project design, but the research also spanned into topics such as product price & ease of use, ease of programmability, and feasibility of design, given limited time and resources. To compare the exciting products in the market we first look at the card access control system, the speaker recognition system, the electric door lock and the PIC microcontroller that tie all subsystem together.

#### **3.1 Card Access Control System**

Card access system will consist of four basic elements. Depending on the size and purpose of the system, there may be many additional types of devices however the four basic elements are: cards, reader, controller and an operator interface. An operator interface is only place where can add and delete cardholders. Our design base on HID Corp products because it is straight forward, and easy to use.

### 3.1.1 Cards/Tags

The term of card or tag can be either used. Any access card simply carries a set of binary numbers (ones and zeros). The card itself has no awareness of the makeup of its format, nor is it aware of any access privileges for the cardholder. Cards can be either passive, active or battery assisted passive. Passive card does not use a battery, while an active has an on-board battery that always broadcasts or beacons its signal. A battery assisted passive (BAP) has a small battery on board that is activated when in the presence of a RFID reader. Most cards contain at least two parts: one is an integrated circuit for storing and processing information, modulating and demodulating a radio-frequency (RF) signal, and an antenna for receiving and transmitting the signal.

An active card is equipped with a battery that can be used as a partial or complete source of power for the card's circuit and antenna. The battery on active card can be replaceable for year of use. The major advantages of an active card are that it can be read at a long distance one hundred feet or more and it can has other sensor that can use electricity for power. There are the problem and disadvantages of an active card. The major issue is battery. An active card cannot function without battery power, which limits the life time of card and typical expensive. Because of the battery, an active card is physical large.

On other side, a passive card is an electronic device that does not contain a battery. It relies on a reader to provide the necessary power for start-up and communication. A passive card can be read if passed within close enough proximity to an RFID reader. The major disadvantage of passive tag is that the tag can be read only at very short distances, typically a few feet at most. This limit is greatly for security entry application. Also, a card remains readable for a very long time, even after the product to which the tag is attached has been sold and is no longer being tracked. The most advantage of a passive card is not using the battery. Therefore, a passive card is smaller, less expensive to manufacture and can have a useful life of twenty years or more unless it is physically abused. The card can also be manufactured with unique data for the purpose of anti-collision, as well as the personalized cardholder data for physical access control

Research has narrowed down to look at certain technology to meet the requirement of hands free entry system. A passive card is more favor by the cost, convenience and the reader range purpose. For the purposed of not contact with the reader, the passive radio frequency identification (RFID) card and a contact smart card has considerate for long range reader.

## 3.1.2 Passive RFID Tag

By Wikipedia the free encyclopedia, a RFID is a technology that uses radio signals to transfer the information from an electronic tag, called RFID tag or label, attached to an object, through a reader for the purpose of identifying and tracking the object. Radio Frequency Identification tags is capable of reading from a greater distance, even in less than optimum environments. Some RFID tags can be read from several meters away and beyond the line of sight of the reader.. The RFID tag includes an antenna and a transceiver unit that uses electromagnetic or electrostatic coupling in the RF portion of the electromagnetic spectrum. The tag's information is stored electronically. An RFID reader transmits an encoded radio signal to interrogate the tag. The tag receives the message and responds with its identification information. Passive RFID tags do not have battery, the power supplied by the reader. There is no battery that can wear out or fail. When radio waves from the reader are encountered by a passive RFID tag, the coiled antenna within the tag forms a magnetic field. The tag draws power from it, energizing the circuits in the tag. The tag then sends the information encoded in the tag's memory.

RFID system design includes a method of discriminating several tags that might be within the range of the RFID reader. Passive RFID tags use the reader as its energy source and it will sends a signal to the reader only when it is in range of the reader. The passive RFID tag consists of an antenna circuit and a silicon device. The reader induces a small electric current when the tag is in range. Then the RFID tag also sends a signal to the Reader. When the tag is not within a design range the door will automatically lock.

### 3.1.2.1 A Contactless Smart Card

A contactless smart card (which uses radio to transmit data) is any pocket-sized card with embedded integrated circuits that can process and store data, and communicate with a terminal via radio waves. There are two broad categories of contactless smart cards. Memory cards contain non-volatile memory storage components, and perhaps some specific security logic. Contactless smart cards do not contain an ordinary read-only RFID, but they do contain a re-writeable smart card microchip that can be transcribed via radio waves. Contactless cards can be programmed with a conventional card data format like 26-bit Wiegand. A compatible reader can read that data and send it on to a controller. The controller can't tell any difference compared to data from a regular proximity (or even Wiegand swipe) card

## 3.1.2.2 Research Cards

As the general definition, RFID stands for Radio Frequency Identification. It provides a unique identifier for that object. RFID tag and contactless smart card technologies are providing very different capabilities as discussed in the previous section. In common, both technologies can be read at longer distances, secure and transmit data through radio signal. Cards can operate at 13.56 MHz or 125 kHz frequency for long range reader. Indala Flexcard, iClass Prox card and ProxCard II are products of HID Corporation which has been used for the purpose of our research.

### 3.1.2.2.1 iCLASS Prox Card

The iCLASS Prox Card combines iCLASS 13.56 MHz contactless read/write smart card and Prox 125 kHz proximity technology on a single card with the ability to add magnetic stripe, barcode, and anti-counterfeiting features including custom artwork or a photo identification directly on the credential. The iCLASS Prox Card meets strict ISO thickness standards for use with direct image and thermal transfer printers. Contactless smart cards are utilized for access control and/or identity verification. iCLASS cards, developed by HID. They are passive devices, requiring no built-in power source. Power is supplied from energy generated in the coil of the card being placed within the radio-wave field of the card reader. A contactless smart card is essentially the same as any regular proximity card. It can be read (and written to) several inches from the reader, and it works really fast. All 2k bit (256 Byte) meet ISO15693 standard for contactless communications which apply for R90 long range reader to get the longer read range. With iCLASS cards, security is handled with challenge and response authentication techniques, data ciphering, and message authentication checks. Uniqueness of cards is guaranteed through serial numbers that cannot be altered.

### 3.1.2.2.2 Indala Flexcard

HID's Indala FlexCard® standard clamshell card is "credit card" length and width, features beveled edges, and can accept photo-flap and direct-print adhesive-backed ID badge overlays. The Indala FlexCard can be programmed in the factory or in the field using the Indala ProxSmith® Programmer and Toolkit with Wiegand, magnetic stripe and serial data formats. For Long-Range Module, Indala Flexcard can have the read range up to 25 inches.

### 3.1.2.2.3 ProxCard II

Proximity is an access control/identification technology that utilizes radio frequency (RF) circuits in microchip form. The microchips are encoded and transmit the encoded information when activated. The proximity card is used with its associated proximity card readers. The proximity card can be design with several options. The proximity card can be a polycarbonate-based card that cannot be run through direct card printers. This card can offer a clip slot pre-punched. The proximity card can be a PVC dual technology card that employs both proximity and magnetic stripe technology. It is comply with ISO standards for thickness (30 mil). This card can allow the printing of cardholder record fields including photo directly on the card.

The RF-programmable Proxcard II is compatible with all HID proximity readers. ProxCard II is offers extremely consistent read range and unaffected by body shielding or variable environment conditions, even when close to keys and coins. Using ProxCard II with MaxiProx reader can produce read range up to 24 inches. The card can fit into wallet or purse. It is light weight, strong, flexible and resistant to breaking.

### 3.1.3 The Readers

The Reader is used to activate the passive tags with RF energy and extract information from these tags. They contain a transmitter, receiver, and digital control module that interface with the operator interface. The reader interfaces with its antenna via an interface chip. If a tag is sensed by the antenna, the reader will transmit the data to controller. The controller will decode the data and pass it to the operation interface where is programmed to lock or unlock the door. The ability to read a tag from much a greater distance requires much more complicated receiver circuitry and the ability to generate a higher power RF magnetic field. Each reader can only talk to its corresponding card type since each of the technologies is unique. HID Corp has provided several card access control system. They are currently available on the markets that are similar to the one we intend to design for our senior design project. Most of these card access control system are universal and can be alone system or PC control. Most of them are capable of learning new codes and because they are universal they are also capable of controlling numerous devices. The reader can communicate with the controller in several methods base on the requirement distance between the reader and controller.. Communication methods will discuss later in the controller section. We look into HID's long range reader product using passive RFID tags have discussed in previous section.

R90 Long Range Reader 13.56 MHZ: R90 Long Range Reader is ideal for long read range applications. The iCLASS R90 is using the 13.56 MHz technology platform with long read range distance up to 18 inches. The iCLASS R90 read

only contactless smart card long range reader with Wiegand output format. It needs 12-24 VDC power supply

Indala Proximity 125 kHz: The Indala 125 kHz Standard has a read range of up to five inches. HID's Indala Proximity access control cards and readers offer an exclusive security technology called FlexSecur® whereby cards and readers are programmed as a unique set for each customer. Therefore, cards belonging to one customer cannot be read by another customer's readers. FlexSecur® provides a dramatic improvement in access control system security at no additional cost, and it works with any access control system. FlexSecur® provides customers with the highest level of security available for 125 kHz Proximity Access Control cards and readers. FlexSecur® can be used with any access control panel because the security is between the card and reader, and is transparent to the panel. FlexSecur® converts even common and frequently duplicated formats such as 26-bit Wiegand, into customer-specific, unique, secure formats where readers and cards are non-interchangeable with those from other systems. It use 4-14 VDC power supply

HID Proximity 125 kHz:MaxiProx Reader is ideal for long read range applications. It has long read range distance up to 6 feet (with ProxPass). MaxiProx is easily interfaced with all existing Wiegand, Clock—and –Data, RS-232, RS-422, and RS-8485 protocol access control system. It needs 12 VDC or 24 VDC power supply.

### **3.1.4 Reader Controller Interface (RCI)**

Reader Controller Interface is build to recognize the card data. The RCI is the only device in the system where the binary card data format can be decoded and acted upon. The RCI will reject the card that does not conforms a specific pre-defined format such as Wiegand, clock/data, serial (RS232, RS422 or RS485). Once the data has configuration it will transmit to an operation interface via Wiegand, RS232, RS485 or USB cable. There are so many configuration modes in RCI to define how the reader can communicate with an operator interface. Following are three popular reader controller interface modes: Wiegand, clock and data and RS232.

#### **3.1.4.1 Wiegand Interface**

The Wiegand interface is wiring standard used to connect access card mechanisms and other security devices to electronic entry systems that read the input information. The Wiegand interface is base on Wiegand effect which was discovered by John R. Wiegand. In the Wiegand mode the serial port is able to receive the data directly from any Wiegand device, such as card reader and also

output the data in the Wiegand format, as if it was a card reader itself. Wiegand interface is popular in the security, access control, and automation industry.

There are two data lines- W0 and W1. Negative pulse on the W0 line represents data bit 0. Negative pulse on the W1 line represents data bit 1. There is no standard Wiegand timing, so pulse widths as well as inter-gap widths vary greatly between devices. Averagely, pulse width is usually in the vicinity of 100uS (microseconds), while the inter-pulse gap is usually around 20-100ms (milliseconds).

There is no explicit way to indicate the end of transmission. Receiving device either counts received bits (if it knows how many to expect) or assumes the transmission to be over when the time since the last pulse on the W0 or W1 line exceeds certain threshold, for example, ten times the expected inter-pulse gap. Below figure 3.1.3.1.1 is shown a standard Wiegand data transmission.

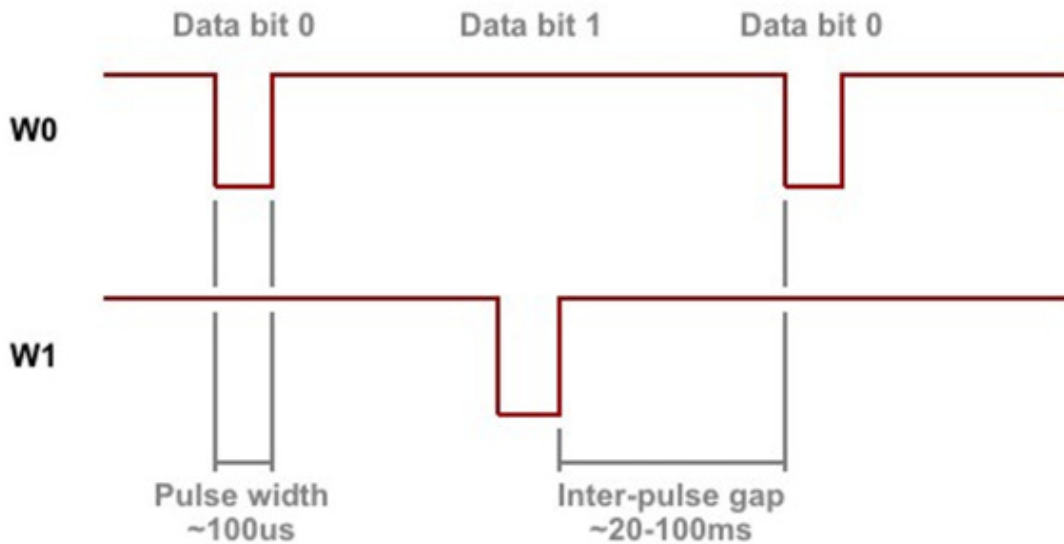

**Figure 3.1.3.1.1: Standard Wiegand Data Transmission**

Figure 3.1.3.1.2 displays the timing pattern for data bit sent by the reader to the access control panel. This timing pattern falls within the Wiegand guidelines as proscribed by the SIA's Access Control Standard Protocol for the 26-Bit Wiegand Reader Interface (a Pulse Width time between 20 uS and 100uS, and a Pulse Interval time between 200uS and 20mS). The Data 1 and Data 0 signals are held at logic high level (above the Voh level) until the reader is ready to send a data stream

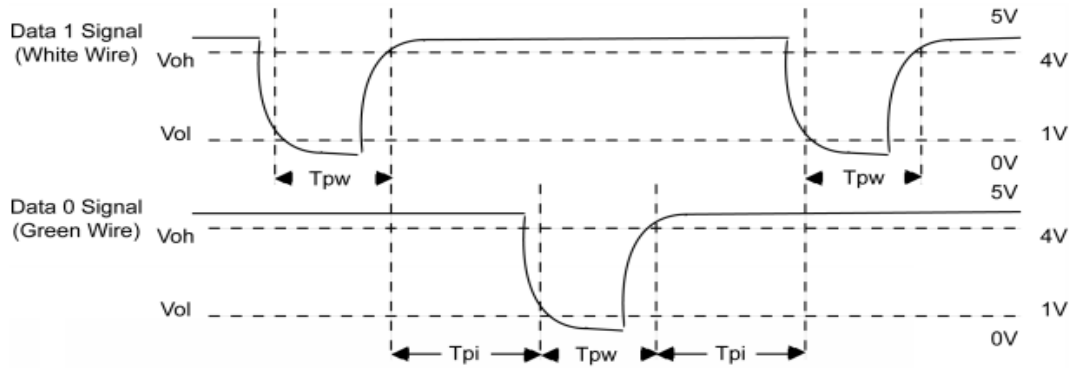

**Figure 3.1.3.1.2: Data Bit Timing Pattern**

The Wiegand interface uses three wires, one grounded and two used for data transmission usually called DATA0 and DATA1 but sometimes also called Data Low and Data High. Zero is pulsed to DATA0 line, while one is pulsed to DATA1 line. DATA0 and DATA1 are at the high voltage (+5V) when no data is being transmitted. DATA0 is at a low voltage while the DATA1 stays at a high voltage when a 0 is transmitted. DATA1 is at the low voltage while DATA0 stays at the high voltage when a 1 is transmitted.

The communications protocol used on a Wiegand interface is known as the Wiegand protocol. The composition of the open de facto industry standard 26 Bit Wiegand format contains 8 bits for the facility code field and 16 bits for the ID number field. Mathematically these 8 facility code bits allow for a total of just 256 (0 to 255) facility code, while the 16 ID number bits allow for a total of only 65536 (0 to 65535) individual ID's within each facility code. Due to the mathematical limitations of the 26-bit Wiegand format, code duplication might occur. An advantage of the Wiegand signaling format is that it allows very long cable runs, far longer than other interface standards of its day allowed. Table 3.1.3.1.1 provides a summary of the 26-bit Wiegand format.

Bit Number	Purpose
Bit 1 (P)	Even parity over bits 2 to 13
Bits 2 to 9 (F)	Facility code (0 to 255); Bit 2 is MSB
Bits 10 to 25 (N)	ID Number (0 to 65,535); Bit 10 is MSB
Bit 26 (P)	Odd parity over bits 14 to 25

**Table 3.1.3.1.1: 26-Bit Wiegand Format**

The sample of a tag ID is as below:

**P FFFFFFFF NNNNNNNNNNNNNNNN P**

**1 0110 1001 1000 0100 0110 1011 1**

There are many Wiegand data formats currently in use. These formats define how "raw" data bits are processed and converted into actual data. Typically, there are 2 parity bits- one at the beginning, and another one at the end of Wiegand data. Parity calculation, however, varies from format to format. Additionally, the length of Wiegand output is not standardized. The figure 3.1.3.1.3 shows how the serial port receives Wiegand data. The serial port does not require an incoming Wiegand data stream to adhere to any strict timing. The port is simply registering high-to-low transitions on the W0&1in line. When such transition is detected, the port checks the state of W1 line. If the line is HIGH, data bit 0 is registered, when the line is low, data bit 1 is registered.

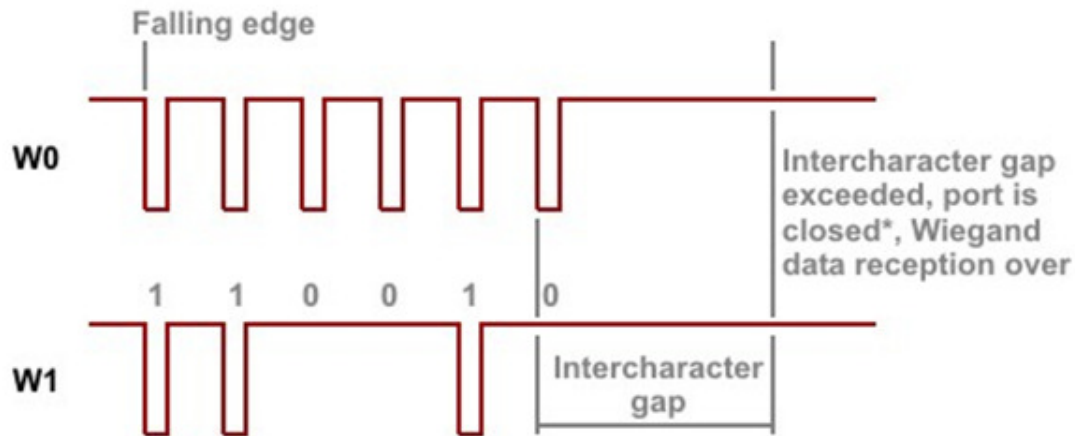

**Figure 3.1.3.1.3: Serial Port Receive Wiegand Data**

The end of Wiegand transmission is identified by timeout- the serial port has a special property for that, called "intercharacter delay". Another property- "auto-close"- can be used to disable the serial port after the delay has been encountered. This way, when the Wiegand output is over the port will be disabled and no further data will enter the port until you re-enable it.

## 3.1.4.2 Clock and Data Mode

In the clock/data mode the serial port is able to receive the data directly from any clock/data or "magstripe interface" device, such as a card reader. The serial port is also able to output the data in the clock/data format, as if it was the card reader itself. Magstripe and clock/data interfaces are popular in the security, access control, automation, and banking industry.

There are two data lines- clock and data. Each negative transition on the clock line marks the beginning of the data bit. The data line carries actual data. When the state of the data line is LOW it means data bit 1, and vice versa. There is no standard clock/data timing and some devices, such as non-motorized magnetic card readers, output the data at variable speeds (depending on how fast the user actually swipes the card). Below figure 3.1.3.2.1 is shows Standard clock/data transmission.

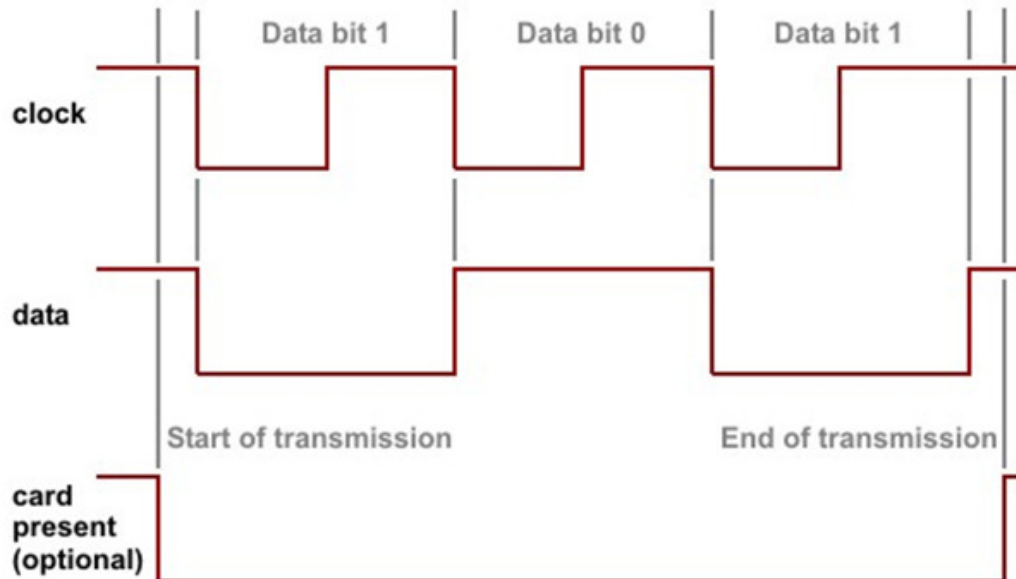

**Figure 3.1.3.2.1: Standard clock/data Transmission**

For the "standard" clock and data consists of two data lines: clock and data. Each negative transition on the clock line marks the beginning of the data bit. The data line carries actual data. It does not require an incoming clock/data stream to adhere to any strict timing. If the line is HIGH, data bit 0 is registered, when the line is low, data bit 1 is registered. The end of clock/data transmission is identified by timeout- the serial port has a special property for that, called "intercharacter delay". The figure 3.1.3.2.2 shows how the serial port receives clock/ data stream

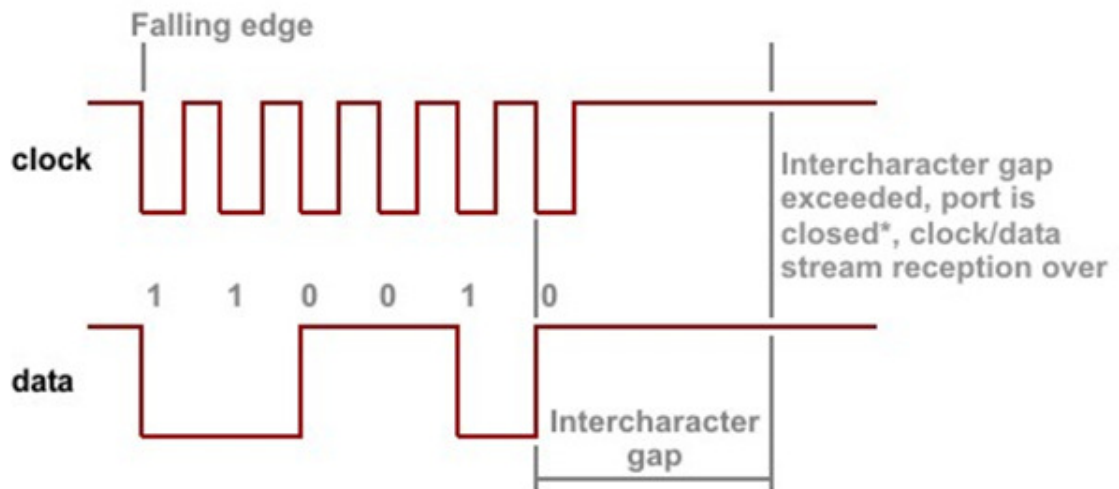

**Figure 3.1.3.2.2: Serial Port Receive Clock/ Data**

### 3.1.4.3 RS232 Interface

Another ways to communicate between devices is RS232 interface. We are using the RS232 protocol for the communication between the devices. The RS232 allows for either seven or eight bit communication and adds a start bit and optional parity and stop bit.

The full-duplex mode of operation is suitable for communicating with RS232, RS422 devices, 4-line RS485 devices, and most TTL-serial devices. Naturally, external transceiver IC is needed for RS232, RS4222, or RS485. TTL serial.

### 3.1.5 Power Supplies

The reader can be operated over the full range of 11.6-28.5VDC. Current requirements are 200-mA average and 700 mA peak at 12 VDC input. At 24 VDC (21 to 28.5 VDC) input the average current is 260 mA and peak is 1.2 A. A linear regulated supply rated at 2.0 A is recommended. The reader converter interface requires a regulated power source of 5VDC or 8 – 16 VDC, 100mA for internal operation. The on-board 5V regulator handles 1A combined consumption so external consumers connected to the 5V bus are limited to 900mA.

## 3.2 Speaker Recognition

### 3.2.1 Introduction to Speaker Recognition

The practice of voice recognition is not a new subject matter. Efforts in the recording and processing of voice data can be traced to no earlier than the 1950s. The first machine developed to recognize speech could determine individually-spoken digits. This was achieved by recording the formant frequencies, which are the peaks of sound pressure in a frequency spectrum, of the spoken digits. The amplitude of a single spoken digit was plotted against the frequency of the vowel portion of the word. When digits were spoken into the trained system they were easily recognizable via pattern-matching (output was, of course, provided, showing that the system did work as intended).

Voice recognition systems were also apparent in popular science-fiction media. Arthur C. Clarke's "2001: A Space Odyssey" saw the inception of "HAL", the "Heuristically Programmed Algorithmic Computer", an artificial intelligence that acts as the crew's support aboard the Discovery One. In George Lucas' epic "Star Wars" the role of AI support came in the form of robots "C-3PO" and "R2-D2". Likewise, Konami video game "Zone of the Enders" had "ADA", an AI developed solely for assisting its user in combat situations.

Simply put, voice recognition is the act of recognizing an identified speaker's speech and converting it into text. In particular, voice recognition systems have to be trained to a specific user, combining the principles of both speaker recognition (identifying the speaker) and speech recognition (determining what words the speaker is saying). The development of voice recognition systems, especially their training methods, is mostly due to the fact that human speech patterns vary from person to person. Accents, in particular, cause these differences to emerge in basic speech recognition systems, causing them to behave in ways not intended.

#### 3.2.1.1 Related Devices

We will examine three devices related to the study of voice recognition.

##### 3.2.1.1.1 Images Scientific Instruments (SI) Speech Recognition Circuit SR-07

The Images SI Speech Recognition Circuit (SR-07) is a simple, inexpensive integrated speech recognition system. With a memory unit of 8K words of length

1 byte, the system can recognize up to 40 words each one second in length, or 20 words each two seconds in length,

The SR-07 can be wired to output to an external devices via pins located on the circuit board. An experienced user can use the properties of a multiplexing unit and various relays to activate up to 40 devices (one word, each one second long, per device). The SR-07 can also be used in conjunction with an external processor in “CPU Mode”. This allows the system to be utilized by a PC system for speech recognition applications without causing too much burden on the PC. It functions as a parallel processor dedicated to speech recognition, including learning and recognizing words. The simplest mode allowed on the SR-07 is “Manual Mode”. It is the mode which allows integration into other peripherals. When not integrated, Manual Mode displays the location in memory of the word being spoken on a two-digit seven-segment LED display. Error codes are also provided, given that the word was spoken into the system: “55” corresponds to a too-long word error, “66” corresponds to a too-short word error, and “77” indicates that the word was not found in memory (not learned). The SR-07 comes pre-assembled for \$179.95 USD. Alternatively, the SR-07 can come unassembled with model number SR-06 (the functionality is the same) for \$114.95 USD. Below figure 3.2.1.1.1 is shows Scientific Instruments SR-07 Speech Recognition Unit and We will further examine the SR-07 in a later section.



**FIGURE 3.2.1.1.1: Scientific Instruments SR-07 Speech Recognition Unit**

### 3.2.1.1.2 inVoca Voice-Activated IR Television Remote Control

Care for the sick and injured is one of the main driving forces behind making voice recognition methods more accessible to the public. In an effort to give consumers more control over their environment, especially if they are quadriplegic, arthritic, or otherwise unable to handle a television remote control, Innotech developed the inVoca Voice-Activated InfraRed Television Remote Control.

Boasting full voice, “totally hands-free” operation, the inVoca can remember the voice profiles of up to four different users using any language, recording up to a total of 50 voice commands or macros. The remote itself is rechargeable with Ni-Cd batteries and can remain in its charging cradle during the entire life of the product or as long as the user requires.

The simple operation allows complete set up using only voice commands as well (although initial setting up by a caretaker, including unboxing the device, other AV device set up and plugging the cradle into a wall outlet, is necessary). Once set to recognize a user’s voice profile, users can set up macros to control up to 4 different AV devices including the television.

Below is a FIGURE 3.2.1.1.2: Innotech inVoca Voice-Activated Infrared Television Remote Control (in cradle. Although the Innotech no longer sells the product, it can be found at many of its distributors typically selling for \$25 USD or less.



**FIGURE 3.2.1.1.2: Innotech inVoca Voice-Activated Infrared Television Remote Control (in cradle)**

### 3.2.1.1.3 iPhone 4S “Siri” Speech Recognition Application

Mobile computing is not a new practice. However, lately Apple, Inc. has been making giant strides towards mobile computing, specifically in the business of mobile phones.

Trend followers of the mobile phone industry (and most people in general) will have heard of the Apple iPhone 4S by now since its launch on October 14, 2011. Improvements to the Apple iPhone series of mobile smartphones include total independence from PC interfacing (users can utilize all the phone’s features, including, but not limited to, updates without connecting to a PC), access to the iCloud storage system (in which apps, music, videos, and any other media available on the iPhone 4S will be readily available in any of the users Apple products), as well as an upgraded camera (8 megapixel still pictures, 1080p HD video recording at 30 frames-per-second). The most notable improvement is the voice recognition system, nicknamed “Siri”.

Siri is the iPhone 4S’s most distinguished feature. It functions as an AI assistant that can make calls, write texts based on the user’s dictation, make reminders, reservations, and so on using mainly voice commands from the user. According to Apple’s Siri web page, users can “talk to Siri as [they] would to a person”.

After a command is spoken into Siri, a speech recognition algorithm detects exactly what words are spoken and performs actions based on that input. For example, the phrase “Remind me about Dad’s birthday tomorrow” prompts Siri to create a reminder of the user’s father’s upcoming birthday. “What is a good Italian restaurant in the area” prompts Siri to load a list of local Italian restaurants, as well as their rating from online sources.

Users also have the ability to freely converse with Siri, similar to the online phenomenon “Cleverbot”. For example, asking Siri “How are you doing today” will result in the reply “I am doing fine, thank you for asking”.

While an exhaustive list of phrases cannot be compiled due to the sheer enormity of possible responses, online communities have been known to post their favorite queries and replies, mostly in the form of YouTube videos.

The iPhone 4S (16 GB model) is currently priced at \$199 USD with 2-year contract, or \$649 USD for an unlocked (non-contract) model.

## 3.2.1.2 Speech Recognition

As stated earlier, the key difference between the two components to voice recognition is that speaker recognition is the process of recognizing the identity of the speaker whereas speech recognition is the process of determining what is said by a speaker. For the purposes of our senior design project, we will be using speaker recognition methods.

A key element of speech recognition is the ability to determine a speaker's words without prior training from that speaker. That is, the system can conform to and handle speech from any speaker, regardless of accent, and process that speech properly.

## 3.2.1.3 Speaker Recognition Overview

Speaker recognition is an entirely separate concept from speech recognition, although the two work hand-in-hand to compose proper voice recognition systems. As such, speaker recognition need not rely on speech recognition to operate fully. This is because the speaker recognition process depends on the "voiceprint" (or spectrogram) of a speaker and not on the words being said.

## 3.2.1.4 Speaker Identification vs. Speaker Verification

It is also important to note the two forms of speaker recognition, which are identification and verification. Their differences are easily discerned in the following explanations and examples.

Speaker identification is the process by which a speaker is identified. That is, from their given voiceprint a system will select key features and compare them to entries from an extensive list of possible identifications. If the speaker's identity is registered as one of those entries, the system can display, in one way or another, the identity of the speaker. For example, a speaker may say "Hello, the weather is nice today!" into the system. The system selects key features from the voiceprint of the speaker and compares those with features from the database of possible identifications. The system sees that the speaker matches the registered identity of one "Samuel Jackson" and informs the speaker (or anyone monitoring the system) that the identity is of Samuel Jackson.

Conversely, speaker verification is the process by which a speaker's claimed identity is compared to his/her voiceprint identity. The point is to verify that the claimed identity (obtained by picture, ID card, or speech recognition) matches the

voiceprint identity provided by the speaker and the database. For example, a speaker walks up to the system and types his name “Joseph Stalin” into the system. He then says “My name is Joseph Stalin” into the microphone. The system obtains the registered voiceprint identity for Joseph Stalin from the database and compares it with the voiceprint provided by the speaker. If the two identities match, then the identity of “Joseph Stalin” is verified. If the two identities do not match, then the speaker is probably not Joseph Stalin (it would be hard to imagine that the speaker is Joseph Stalin in the first place). For the purposes of our senior design project, we will be using speaker verification methods.

### 3.2.1.5 Text-dependent vs. Text-independent

The process of speaker recognition (both identification and verification) can further be divided into two subcategories: text-dependent and text-independent. Their differences are noted here.

Text-dependent systems are the easiest (relatively) to implement because a speaker provides a finite number of sayings that future testable voiceprints can be compared to. For example, a speaker can provide the three primary colors (red, blue, and yellow) to the list of testable words for their registered voiceprint identity. In the future, whenever that speaker must be recognized by the system, they will only use those words (red, blue, or yellow) to determine or verify their identity. The use of words not included in that set would result in failure to perform either action. The obvious con to this method is that the speaker cannot exercise the freedom to speak any words into the system that are not included in their predefined set of passwords. Additionally, this method, when compared to text-independent implementations, is less secure (although the difference is often small enough to be, more or less, unimportant). For the purposes of our senior design project, we will be implementing a text-dependent system.

Text-independent systems are more difficult (once again, relatively) to implement. This is because the speaker does not have to select from a predetermined list of passwords to use at the time of recognition. For example, the speaker may use the phrase “obtuse angle” to verify his identity on one occasion. However, in the future the speaker may or may not use the phrase “obtuse angle” to pass the system once more. The decision can or cannot be entirely up to the speaker as well. The speaker may have the freedom to select a word, chosen completely at random without influence of any kind, and speak that word into the system. Conversely the speaker may be given a word (or more words to select from) to speak into the system. It can be written in the form of a note or displayed on a screen or even said over a speaker (the *electronic device*, not the person). The speaker (person) may then say that word into the system, and his identity can be identified or verified as needed.

Speaker recognition can be best summarized by the following diagram.

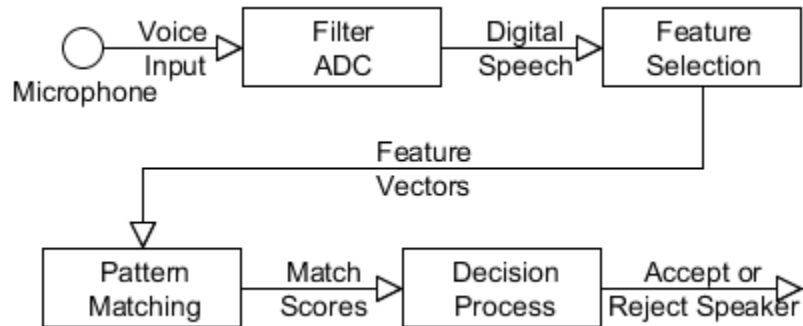

**FIGURE 3.2.1.5: Typical speaker recognition process**

Systems typically follow this model. Each box represents a different modular process. As such, each process can be different depending on the needs of the system in particular as well as the number of users accommodated by the system. Filtering and analog-to-digital conversion (ADC) is typically performed by hardware. Methods of feature selection and pattern matching have their strengths and weaknesses. A select few are outlined in the next two sections.

## 3.2.2 Methods of Feature Selection

There are many methods feature selection available when robust and efficient speaker recognition is to be achieved. We will examine two methods here, Linear Predictive Coding (LPC) and Mel Frequency Cepstral Coefficients (MFCC), respectively.

### 3.2.2.1 Linear Predictive Coding

Linear predictive coding (LPC), or simply linear prediction, is a fairly new, relatively simple form of speech processing. It is a technique that analyzes the outstanding frequencies produced by the vocal tract, or formants (peaks in amplitude for a given frequency; can very loosely translates to vowel sounds), during speech, as well as the popping (consonant sounds for “t”, “d”, “k”, “g”, “b”, and “p”; also known as “plosives”) and hissing noises (“s”, “sh”, “z”, “ch”, and “j”; also known as “sibilants”) present in regular human speech.

The method revolves around the ideas that a frequency is produced by the vocal folds, which controls the frequency and amplitude of a speech sample, and then effectively filtered by the vocal tract (composed of the lips and tongue). These two components collectively form the source-filter model of speech production.

In analysis of the speech sample, the method first removes plosives and sibilants from the sample, leaving behind the formants as well as the underlying speech sound. Through inverse filtering the formants are found and removed as well; the remaining sound is called “residue” and constitutes the base sound produced by the vocal folds in the larynx.

An interesting feature of LPC is its ability to replicate human speech by reproducing the residual sound, then adding formant sounds, plosives and sibilants where appropriate (this can be determined by finding the consonants in text and adding the formant and plosive or sibilant characteristic of that consonant). The result is synthesized human speech. Although the method is considered crude it is the most realistic in accurately depicting the production of human speech.

The following is a basic example (note: note an actual implementation) that shows how LPC can be used to deconstruct a speech sample (“superman”). We first start with the speech sample itself, complete with base, formants, and plosives and sibilants.

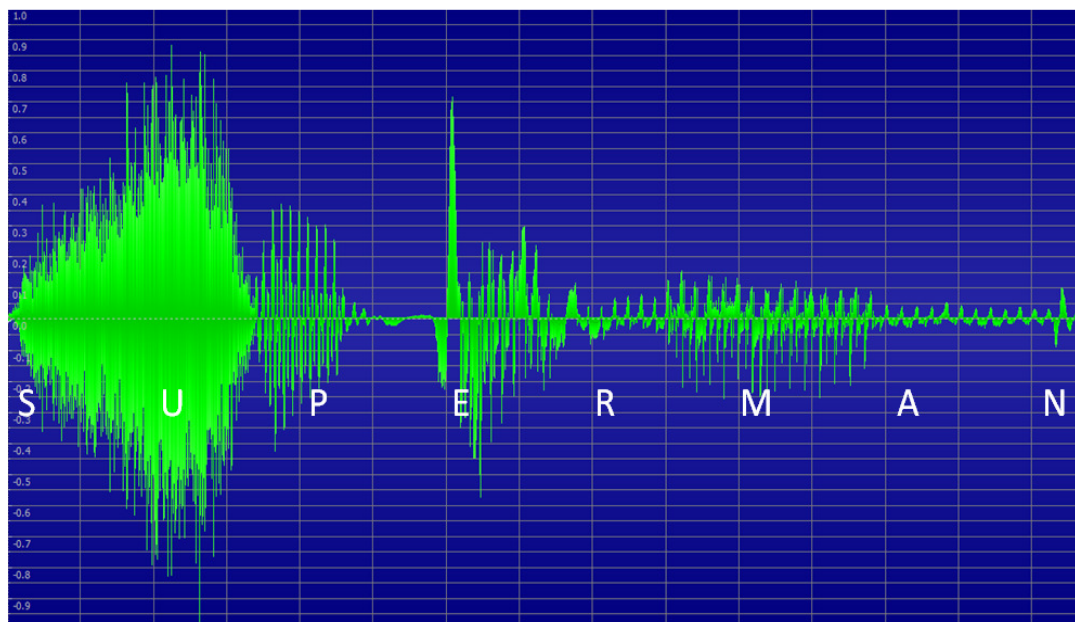

**FIGURE 3.2.2.1.1: Time-variant waveform of spoken word “SUPERMAN”, no inverse filtering**

Notice the high amplitude (and thusly, power) where the consonants “S” and “P” are being spoken, as well as the vowel “E”. From this full sample we remove the plosives and sibilants, resulting in the following waveform.

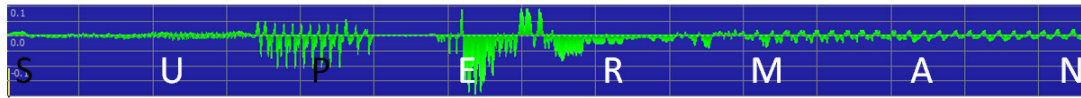

**FIGURE 3.2.2.1.2: Time-variant waveform of spoken word “SUPERMAN”, plosives/sibilants removed/reduced**

We can tell that the sibilant “S” was the most powerful component of this speech sample such that, when sibilants were completely removed, majority of the waveform at that point in the sample was reduced to near zero amplitude. Plosive “P” was mostly removed. Parts of “E”, “R”, “M” and “N” were also reduced. Next a filter was applied to remove formants.

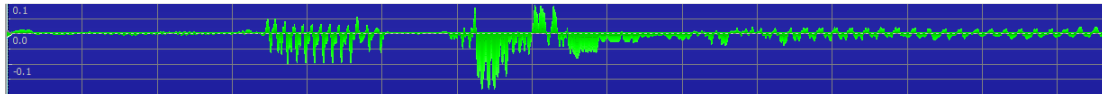

**FIGURE 3.2.2.1.3: Time-variant waveform of spoken word “SUPERMAN”, estimated amplitude peaks removed**

Peaks of amplitude were removed (formants) and this is the resulting residual waveform. Most of the vowel “E” and “A” remained the same from the previous waveform.

In the process of reconstructing the sound using a speech synthesizer, the residual frequency (source) would be played. The locations of formants would be estimated and the formants restored, reproducing the vowel sounds. Lastly, plosives and sibilants (themselves patterned from various other speech samples) would be added where the corresponding consonant sound occurs during speech and the synthesis is complete. The result is a waveform similar to the first waveform, but more “machine-like” in character.

There are different representations for coefficients of LPC, two of which are the logarithmic area ratios and line spectral pairs. However, they are used mainly for transmission across a medium (such as radio waves for GSM communications) and thusly beyond the scope of this report. In fact, the logarithmic area ratio representation is almost obsolete when compared to line spectral pairs.

Feature selection in the form of LPC itself would be of selecting the plosive, sibilant, formant, and residual patterns characteristic of the speaker. Although the algorithm itself is simple, straightforward and most accurately represents human speech activity, it isn’t a very robust solution as changes in a speaker’s voice in the long term (or due to sickness, injury, or otherwise) are known to affect

verification accuracies. A more robust solution would be mel frequency cepstral coefficients, which we will examine in the next section.

The use of LPCs does not apply only to speech deconstruction and synthesis for devices similar to our proposed speaker recognition system. In the absence of speech residue, the source is replaced by instrumental notes before filters are applied. The effect is best described as “singing instruments” and is seen primarily in the use of “talkboxes”.

### 3.2.2.2 Mel Frequency Cepstral Coefficients

Mel frequency cepstral coefficient systems are, with little doubt, the most widely used in feature selection because of its simplicity, robustness, and efficiency. It makes use of the mel (from “melody”) scale, which is the scale pitches perceived to be equidistant from each other. Do, Re, Mi, and so on are pitches on the mel scale, with octaves between pitches having twice the frequency of the lower pitch (for example, the pitch C4 has frequency of approximately 262 Hz, while C5 has frequency of approximately 523 Hz. The “mels” of a frequency can be computed with the following equation:

$$m = 2595 * \log_{10}\left(1 + \frac{f}{700}\right).$$

The mel scale is seen as linear for frequencies below 1000 Hz and logarithmic for frequencies above 1000 Hz.

The robustness of MFCCs are attributed to its usefulness over the long term as the vocal chords of a speaker change, such as aging, sickness, smoking, and so on, as well as its ability to recognize speech features in the presence of background noise, such as those found in a traffic, mall, campus, or other setting.

There are a number of steps in obtaining the MFCCs from a voice sample. It can be summarized by the following diagram.

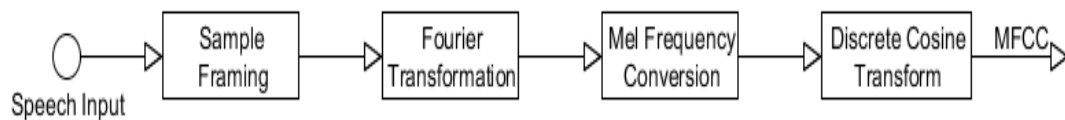

**FIGURE 3.2.2.2: Basic process for computing MFCCs of a speech sample**

Here we will discuss each step in detail, starting with the framing problem.

*Sample Framing* – All sounds, including speech, can be represented by a time-varying function (frequency vs time). We can say that for a one-second sample of

speech, the frequency varies somewhat greatly throughout the sample. Dividing that sample in half, we see that the frequency in each half-second segment doesn't vary to the same extent as the full sample but is still too varying for us to obtain MFCCs. As the signal is further subdivided into sections we see that each section only contains a single frequency with each section possibly having different frequencies. Each sample can then be processed by Fourier transformations.

*Fourier Transformations* – A Fourier transformation in its simplest definition is the conversion of a time-varying signal into sine or cosine frequency-varying waves (from a time domain to a frequency domain). The Fourier transformation, named for Joseph Fourier, obtains the power of a frequency and represents it as a sine or cosine function. The transformation is modeled by the function

$$\hat{f}(\xi) = \int_{-\infty}^{\infty} f(x)e^{-2\pi i x \xi} dx$$

where  $x$  represents time in seconds and  $\xi$  ( $\xi$ ) represents the frequency in hertz.

While the above function represents the Fourier transformation over a continuous set of frequencies, there exists its discrete, more widely-used, counterpart dubbed the Discrete Fourier Transformation (DFT).

Unlike the Fourier transformation which is integrated over time  $x$  from negative to positive infinity, the discrete Fourier transformation is represented as a summation in the function

$$X_k = \sum_{n=0}^{N-1} x_n * e^{-i2\pi \frac{k}{N}n}$$

The values obtained for  $X$  are complex numbers representing the amplitude and phase of a given sinusoid.

Obtaining the exact discrete Fourier transformation of any sample is costly and time-consuming. However, different variations of the Fourier transformation, appropriately called Fast Fourier Transformations (FFT), have since been developed by various mathematicians for the purposes of cutting calculation time while maintaining accuracy, though in some cases FFT can be more accurate than non-FFT calculations where rounding errors can occur. Though there are numerous FFT algorithms available, we'll examine one such algorithm, the Cooley-Turkey FFT.

*Cooley-Turkey FFT* – The Cooley-Turkey FFT, named for JW Cooley and John Turkey who developed it while working in IBM's research division, is the most-used FFT. It is a recursive function that divides a DFT of a large size  $S$  into smaller DFTs of size  $S/n$ .

The simplest form of the algorithm uses a division size of  $n = 2$ . The Radix-2 Decimation in Time (radix-2 DIT) divides the total DFT into even- and odd-indexed DFTs. Computational analysis finds that the time for calculating the final DFT is  $O(N \log N)$  as opposed to  $O(N^2)$ . The equation for the Cooley-Turkey FFT is represented by

$$X_k = \sum_{m=0}^{\frac{N}{2}-1} x_{2m} e^{-2\pi i \frac{2m}{N} k} + \sum_{m=0}^{\frac{N}{2}-1} x_{2m+1} e^{-2\pi i \frac{2m+1}{N} k}.$$

*Mel Frequency Conversion* – Once the set of frequencies are obtained from FFT, they can be converted into mels with the conversion function stated earlier, reproduced here:

$$m = 2595 * \log_{10}\left(1 + \frac{f}{700}\right).$$

*Discrete Cosine Transform (DCT)* – The last step in finding the MFCCs of a speech sample is performing a discrete cosine transform of the base-10 logarithm of the mels obtained in the step above.

A discrete cosine transform is similar to a Fourier transform in that data is represented as a sum of sinusoids each with frequencies and amplitudes. In the case of DCTs, a set of finite, discrete points are represented as a sum of cosines with amplitudes. Though there are many “types” of DCT including inverse functions, we will examine DCT-II, the most commonly used DCT.

The DCT-II function is

$$X_k = \sum_{n=0}^{N-1} x_n \cos\left[\frac{\pi}{N} \left(n + \frac{1}{2}\right) k\right]$$

for all  $k = 0$  to  $N-1$ .

Although a sum of cosines is obtained from this function, only the amplitudes of each given frequency is necessary – these amplitudes for the frequencies compose the mel frequency cepstral coefficients.

MFCC aren’t only useful in speaker recognition applications. Researchers have found that the use of MFCC in recognizing MP3 encoded music is shown to be very robust. Making use of this method are a collection of mobile smart phone “apps” that allow users to determine the artist, title, album name, or other piece of information about a song by having their phone “listen” to a sample of the music (holding it up to a stereo playing the song).

(Trivial note: The word “cepstral” is actually derived by reversing the first four letters in “spectral”.)

For the purposes of our senior design project, we will be using mel frequency cepstral coefficients as our feature selection method.

## 3.2.3 Methods of Pattern Matching

Feature selection occurs prior to pattern matching against a database of known values for the features chosen. Pattern matching can be considered the final step in speaker recognition (verification) if the decision process is included. We will now examine two methods of pattern matching, Hidden Markov Models (HMM) and Vector Quantization (VQ), respectively.

### 3.2.3.1 Hidden Markov Models

The Hidden Markov Model (HMM) is a mathematical concept based on the life work of Andrey Markov, a Russian mathematician who concentrated on the theory of stochastic processes (later known as “Markov chains”). Although the HMM was developed in the late 1960s, its usefulness in various speech applications did not become apparent until the mid-1970s, where it was implemented in a speech recognition algorithm. It can go without say that, although the HMM can prove useful in applications not relating to the field of speech processing, the central focus of HMM is of voice and speaker recognition applications.

The HMM can be described as simply as follows: assume you have a finite number of states,  $N$ , of which you cannot **directly** observe – in other words, these states are **hidden**. However, as a contextual clue to what the current and, subsequently, the next state can be are specific symbols that act as an observational guide. Assume also that each state has a probability distribution of transitioning to another state, which can include itself. Lastly assume that each state has another probability distribution of displaying a certain observable symbol out of a given array of observable symbols. We have constructed a model that has the most basic elements of a Hidden Markov Model.

#### 3.2.3.1.1 The Babysitter Example

Here is another example that focuses on the possible non-linearity of a HMM. That is, each state can transition into multiple states. However, each state can only have one observation.

Imagine that you are a babysitter for a young, 10-month-old baby boy. We know that babies have needs, such as being fed, having their diaper changed, being put to bed, and so on (but for the purposes of this example, we will only assume those three are the only needs at this time). Because you wish to prove yourself as an exceptional babysitter, you will perform certain tasks to meet the needs of the baby boy in an effort to please his parents and earn your pay for the night. However, you are unaware of when to do what. That is, unless you know the

cues and clues that you can directly observe. Until you can observe these clues, you cannot make an informed decision of what to do. Thankfully, you can apply a HMM to the situation.

First let us make a few more simple assumptions about what is going on during your babysitting job. The baby needs to be fed only once tonight, and his food container is transparent and always visible to you. The baby is within the proximity that you can always see and hear him, as well as smell whether or not he has had an “accident” recently. Our last assumption is that no other outside forces can interact with the baby, nor are there any other possible states.

Now we can define the hidden states the baby may have. As we have defined earlier, the baby needs only to be fed, have his diaper changed, or put to bed. Coincidentally, these are our three states, “hidden” in the sense that you don't know which one to assume is the current state unless you look at the observable details. Said details (observations) are as follows: (1) the baby is crying, has no smell (an indication of a clean diaper), and hasn't eaten (remember that the food container is always in view); (2) the baby is crying, has a potent smell lingering about him, and has not eaten yet; (3) the baby is crying, has a potent smell lingering about him, and has already eaten; (4) the baby is crying, has no smell, and has already eaten, and; (5) the baby is not crying (the other observable details are irrelevant).

As we defined earlier, each state can have only one observable detail but can transition into multiple states with a given probability distribution.

If the baby exhibits observation (1), we can safely assume that the baby is hungry and needs to be fed. Because you are proving your babysitting prowess you promptly feed the baby as he transitions to his next “state”.

If the baby exhibits observation (2), the baby's diaper will most likely (with probability 1.0) need changing. Remember that a baby is powerless in changing his own diaper; you immediately change his diaper into a clean one, while the baby transitions into his next state.

If the baby exhibits observation (3), the baby's diaper needs changing. The key difference between this and the previously mentioned state is that the baby has already eaten his dinner.

If the baby exhibits observation (4), he is most likely cranky and wishes to be put to bed, but does not feel comforted in any way. As your maternal instinct kicks in you pick up the baby and cradle him in your arms until he becomes silent. You lay him down in his crib while he transitions into his next state.

If the baby exhibits observation (5), chances are he is sleeping soundly in his crib or has no other issues bothering him to the point of crying. It is a clear indication that you are doing your job well and will be rewarded handsomely for the care of another human being.

The following figure 3.2.3.1.1 is a diagram summarizing the babysitter example.

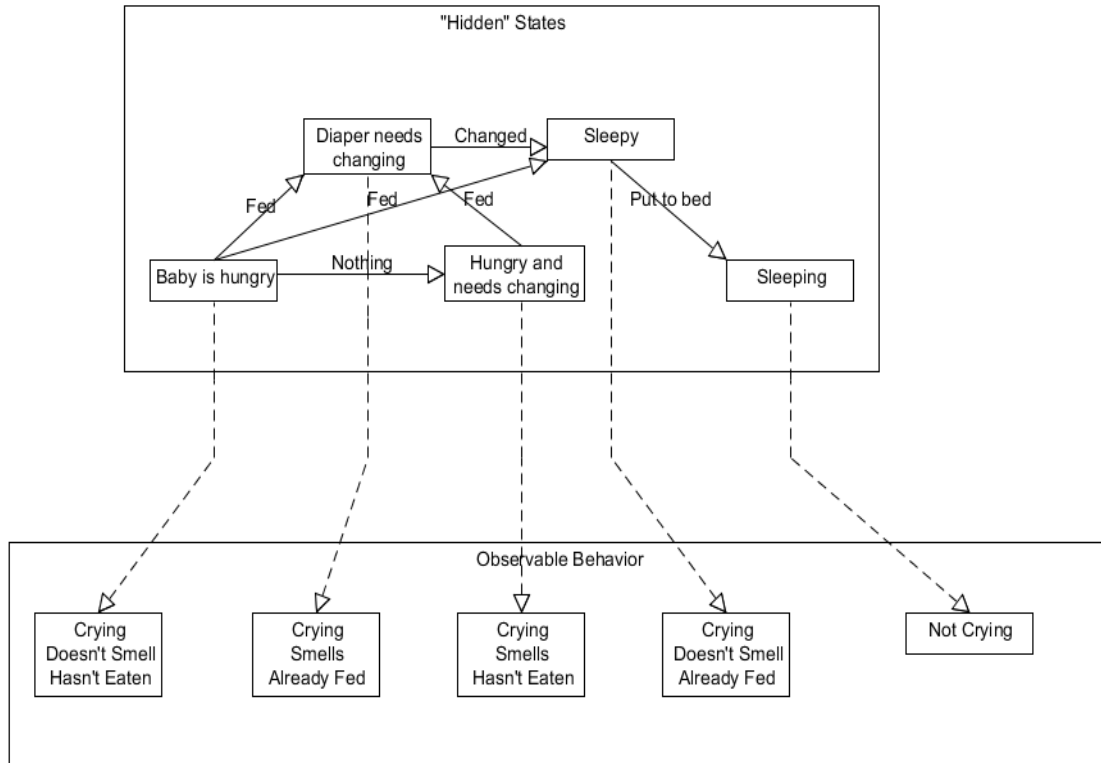

**FIGURE 3.2.3.1.1: Pictorial summary of “Babysitter Example”**

Dashed arrows map the hidden states to the observable behavior. Solid arrows show the possible hidden state changes between states.

It is very important to note that, although these states can occur in the order listed, it is very possible that one state can transition into two or more states. A baby in his “quiet” state can easily transition into any of the other states (although it is not expressed in the diagram above for simplicity). A baby that has been fed can transition into any other state as well (with the exception of the “unfed” states). However, only after the baby has been fed and its diaper changed can it be put to bed, as children put to bed without dinner or in dirty diapers can be considered child-abuse (and that is certainly a state we don't wish to attain). At the end of the night, depending on your ability to react to the observable signs (which includes correctly determining the state the baby is currently in), your ability as a babysitter will be rated by his parents, which we sincerely hope is a favorable one.

For the purposes of this senior design project, we will be implementing hidden Markov models for our pattern matching algorithm.

## 3.2.3.2 Vector Quantization

### 3.2.3.2.1 Basic Definition of Vector Quantization

Vector quantization (VQ), like HMM, is a fairly straightforward approach that, given a two-dimensional space, determines the centroids of clusters.

At its simplest, the VQ method of pattern matching can be implemented and described by the following. Given a two-dimensional space of units  $M$  (domain) and  $N$  (range), we'll assume a certain number of centroids  $C$  exist in that space. For instance, let us decide to have 5 centroids in the space.

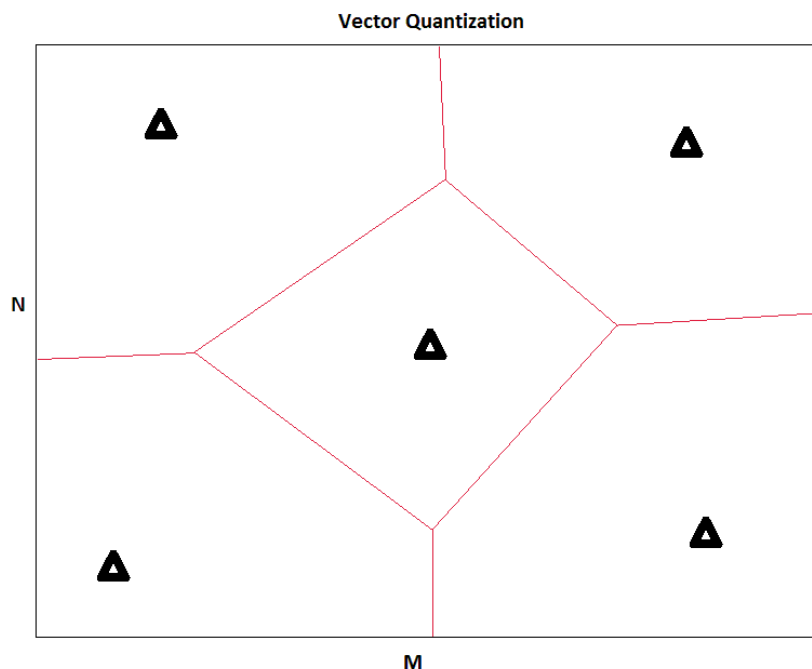

**FIGURE 3.2.3.2.1.1: Initial two-dimensional VQ space with user-defined centroids**

The triangles represent the given centroids. The quadrilateral regions enclosed by the red lines represent the effective regions surrounding each centroid. As the first sample of data is obtained, the points are added to the space. When a data point is the first to land in a region, the centroid of the region equals that data point.

As more and more points are added to the space, the centroid within that region will become the centroid of the collection of points in that region. The equation for finding the new centroid for a region, given all data points P with location (x, y) is simply

$$(x_c, y_c) = \left( \frac{\sum_{n=1}^N x_n}{N}, \frac{\sum_{n=1}^N y_n}{N} \right)$$

where (x<sub>C</sub>, y<sub>C</sub>) is the new centroid position, N is the number of data points in the effective region of the centroid, and n is the index of the sample data points.

The resulting space can look like this:

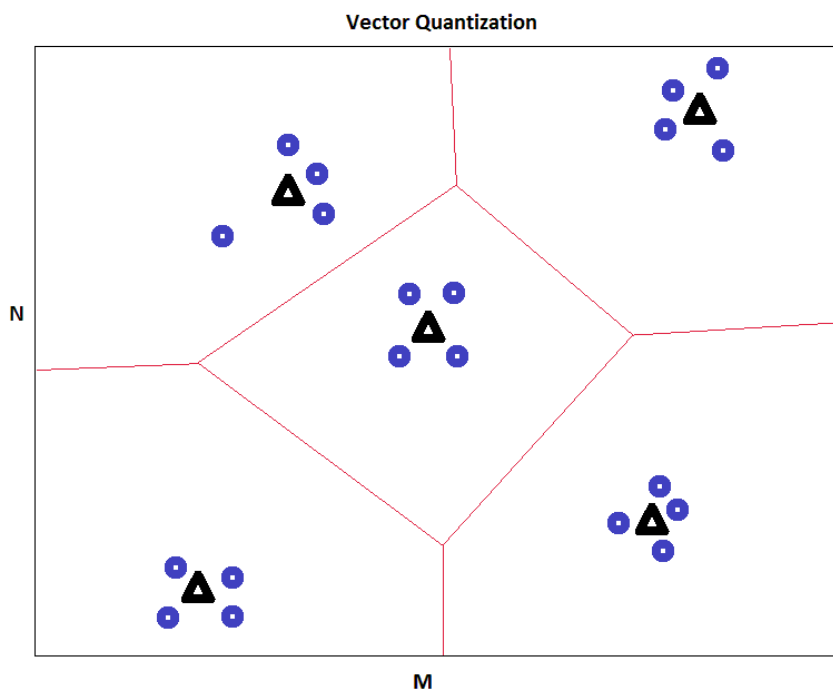

**FIGURE 3.2.3.2.1.2: Resulting two-dimensional VQ space with sample data points and adjusted centroids**

In this case, the positions of all 5 given centroids shifted toward the actual centroids of each effective region. Here is the resulting space overlapping the original space to compare the actual centroids after data has been sampled to the given centroids before sampling. The given centroids are slightly faded for clarity, and the region lines are removed.

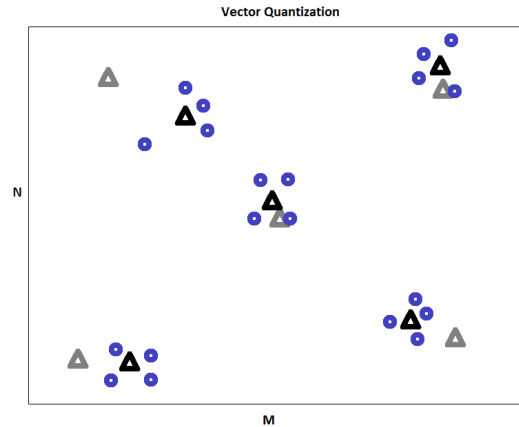

**FIGURE 3.2.3.2.1.3: Two-dimensional VQ space overlapping result over initial spaces**

It is possible, as in this figure, that a given centroid's position can be a great distance from the actual centroid of the sampled data points. Given more sample data points, one can even estimate the position of future sample data points. In that case, the expected value of a new data point is simply the value of the region's centroid at the time of estimation.

VQ becomes apparently useful in a speaker recognition application when comparing a speaker's claimed identity with the identity obtained from a database.

### 3.2.3.2.2 Confidence Rating and Note

In one implementation of VQ that maps the power spectrum of speech onto the space, after the learning phase we can assign, or construct such an algorithm that assigns, each centroid a radius of sensitivity. Given a speaker's input speech sample with data points similar to the ones obtained above, if each data point lies within a centroid's radius of sensitivity we can say that the speaker's identity has been verified. Otherwise, we can say that the speaker's identity has shown to match the claimed identity with a certain confidence given by

$$\text{Confidence} = \frac{\# \text{ of sample data points that fall within a radius}}{\# \text{ of radii in the space}} * 100\%.$$

Lastly, it is important to note that assigning more centroids (and consequently more effective regions) confidence will approach desirable numbers ( $\rightarrow 100\%$ ) coupled with more correct identity matches than mismatches, especially in a setting with a large number of users ( $\sim 10$  or  $\sim 15$  registered profiles).

## 3.2.4 Speaker Recognition Conclusion

We examined a brief history of speech recognition systems, devices related to our project, and outlined different methods of feature selection and pattern matching.

For the purpose of fulfilling the specifications described in this project report, we've chosen mel frequency cepstral coefficients (MFCC) as the method of feature selection because of its robustness in selecting features in the presence of slight variations in vocal folds of the speaker as well as ambient noise like that of a traffic, mall, or school setting. Hidden Markov models are the choice of pattern matching for its straightforwardness and ease of implementation.

## 3.3 Door Lock System

Door Lock System will consist of four basic elements. Depending on the size and purpose of the system, there may be many additional types of devices however the four basic elements are: electric lock, request to exit push button, power supplies and door controller and door hardware.

### 3.3.1 Electronic Access of Doors

Electronic access of doorways can be accomplished utilizing magnets, solenoids or motors to both deny and gain access to an entry. These devices in conjunction with a means of control can allow remote actuation and enhance both security and convenience.

#### 3.3.1.1 Electric Strike & Buzzer

Also called electric latch release they replace a standard strike mounted into the door frame and receive the latch and latch bolt. It has a drop away side that as energized moves out of the way of the door mounted lockset. Latches are set to default as either lock safe or lock secure. This is the mode that the lock would be in if the power were lost. Bear in mind that it will generally be possible for the subject on the interior side of the door to turn the door knob and leave, lessening concern about lock safe and thereby giving lock secure consideration. Voltages typically run from 12 to 24 volt. Typical current draw is in the range of 450 ma. Locksets are designed specifically to match the door frames that they might utilize. Electric strikes can be simple to install when matched to door; otherwise if not designed as a drop-in replacement for a standard strike can require extensive modification of the door frame. Wood, fiberglass and steel are the typical construction materials. Wood tends to be for residential use with steel for

commercial applications. Latch construction is typically stainless steel to hold up to the harsh external environment and moisture caused by residing between these two worlds that locksets inhabit of both interior and exterior. Aesthetically, the door latch needs to be mounted unobtrusively into the door jamb utilizing typical installation cutouts to maintain an attractive outcome. Although not necessary for operation, a buzzer will be considered for this application to provide an audible signal that the strike has been actuated. Because of the requirement to satisfy both RFID and Speech Recognition, a buzzer would insure that the subject entering was signaled that the door was unlocked



**FIGURE 3.3.1: BUZZER**

### **3.3.1.2 Electric Lock**

Electric locks use magnets, solenoids, or motors to actuate the lock by either supplying or removing power. Operating the lock can be accomplished using a switching device such as a pushbutton or more exotically through the use of a managed control system.

### **3.3.1.3 Magnetic Lock**

The most basic type of electronic lock is a magnetic lock (commonly called a mag lock). A large electro-magnet is mounted on the door frame and a corresponding armature is mounted on the door. When the magnet is powered and the door is closed, the armature is held fast to the magnet. Mag locks are simple to install and are very attack resistant. One drawback is that improperly installed or maintained mag locks can fall on people. and also that one must unlock the mag lock to both enter and leave.

### **3.3.2 Request to Exit Push Button**

The user may desire to exit the interior while utilizing the electric latch. This might be because they want to have minimal contact with the door hardware because they are otherwise disabled. This type of door switch tends to be priced by its current rating where a higher rating demands a higher initial cost. The voltage ratings as well need to be considered. In this case a typical size would be for a range of 11.6-28.5VDC. Typical requirement for a door exit application would be a N.O. or Normally Open switch to be surface wall mounted on the interior side of the door and shall be denoted as push to exit.

### **3.3.3 Power Supplies and Door Controller**

Power supply specified shall be a class 2 120v 60 Hz AC to 12v AC transformer. This transformer shall be self-contained with prongs to plug into a normal wall outlet. It shall be rated no less than 450 VA and its conductors shall sized accordingly. It shall be suitable of carrying this load with a +/-5% voltage tolerance. Additionally, shall not exceed 90 degrees Fahrenheit when operated at 80% of designed load. While operating over the range of 11.6-28.5VDC. Current requirements are 400-mA average and 700 mA peak at 12 V input.

Door Controller shall be provided with a rectifier circuit capable of a 12volt ac input for conversion to latch 12volt dc for the electric strike. Additionally, it shall contain a timer circuit with adjustable pot drives time from 1 second to 30 seconds with approx. 1 second intervals. Relay cube on board shall be designed for amperage draw from the electric latch and shall provide a normally open circuit for the processor feed to control the electric strike. The size of the board shall be small in stature allowing convenient installation near door frame.

### **3.3.4 Contrast of Devices / Vendors of Electronic Security Devices**

When researching components for the prototype of these devices it appeared there were four fairly clear delineations of suppliers. Electric latches will be used as the example. First was the high quality, USA made specification grade items. In this case Von Duprin their items far exceeded all the other items in quality and testing. This column of parts; however, were on an order of four times the expense. Second, in this characterization of parts was the very good quality but still very pricey more than likely made in the US or recently moved to Mexico plant. Examples of this would be HES and Adams Rite. Both could be used for a fairly well exercised entry to a commercial facility. Third in pricing and quality were made in Taiwan / China but boxed and UL Listed very much like the US / Mexican made goods that were of a very good quality. Closer analysis of the specifications and visual quality revealed that they were more for the use in a

lower category of commercial and of a decent residential level door assembly. The final category was items direct shipped from China with sparse documentation. These items were very inexpensive. There was a time when this type of item was called “gray market” meaning that they were unsupported in any country other than that of origin. In the event that repair was needed, it was not economically realistic to try to receive parts and a throw away mindset was dictated. For this prototype all four of these product lines was researched with the second to the bottom one immediately dismissed. In the case of the electric strike, for example, why pay 1/3 the cost of a high quality item for something that could be purchased of the same quality sans the paperwork and dealer network for 1/10<sup>th</sup> the cost through direct shipping. Additionally, the first category (that which was most expensive) was dismissed fairly quickly. For this prototype there was no need to purchase an item that would last, if well maintained, for a generation or two. It was not economically realistic that this prototype could justify this cost nor could a subsequent production of our product line should it be placed into manufacture. This first category truly was for an entryway like that of a government building visited by a very large number of patrons daily or annually. This left two categories, the second column of good quality or the last column with questionable testing and documentation. Since we had plenty of lead time we chose to go with the least expensive of all of the offerings and would use our time to adequately test the product to see if it met with minimum standards of operation keeping in mind that with the quick turnaround time an item could be quickly changed out for the 2<sup>nd</sup> highest quality level. The items were chosen and the following table shows the costs both economically and in quality for this decision.

<b>Contrast of Various Vendors of Electric Strikes</b>				
<b>Manufacturer</b>	<b>Von Dupnir</b>	<b>HES</b>	<b>Adam Rite</b>	<b>YLI</b>
Part Number	6214	HES 5000	7440	YS-131 NO
Retail Cost	\$476.44	\$148.00	150.55	\$27.51
Availability	Next Day Shipping	Same Day Shipping		2 week lead time
Pros	Industry standard exceptional quality	Very High Quality for price		Extremely low cost inverter board
Cons	Highest Price	Price still daunting		Unanswered spec.
Notes	1500 lbs. holding strength.	Static strength 1,500 lbs.	Static strength 1,500 lbs.	
	70 lbs. impact strength.	Dynamic strength 70 ft-lbs	Dynamic strength 70 ft-lbs	
	Tested to over 250,000 cycles	Endurance 500,000 cycles	Endurance 500,000 cycles	
	Furnished fail secure (FSE) standard, with fail safe (FS) optional	Field selectable Fail secure/ fail safe	Field selectable Fail secure/ fail safe	Fail Secure
	Furnished 24VDC standard with 12VDC and AC operation optional	Dual voltage 12VDC or 24 VDC continuous duty	Dual voltage 12VDC or 24 VDC continuous duty	12VDC
	Two piece plug connectors are furnished for ease of installation and for removal during strike servicing	Plug in connector	Plug in connector	

**FIGURE 3.3.4: ELECTRIC STRIKE CONTRAST**

### 3.3.5 Door Hardware

Door materials to be considered are wood, fiberglass and steel. Wood is often chosen due to its versatility and low cost. It is easy to drill, fasten hardware to and repair or patch should modifications need to be made. Additionally, wood is used in either residential or commercial installations. Steel can be difficult to cut, grind and patch back in should upgrades/changes be needed. Fiberglass as well holds some daunting prospects as repair can be a time consuming prospect as it is layered back together in the event of a change. Another consideration is whether to use an interior or exterior door. The application taking place, availability and value generally decide the outcome. Running security cabling through a wooden door and frame can be a bit more difficult than chasing through a metal one; however, with the proper pre-planning and tooling, it should not be prohibitive.

The door status switch is placed in the door frame and is interconnected to the processor. This magnetic proximity switch is a normally open set of contacts and shows a change of state when the door opens. Although not necessary for the operation of the various systems, it will give the processor an indication that can be used to determine if the door has been blocked open, etc. It is inexpensive and very easy to install during initial construction and might add value at a later date when it is determined that this feedback is desired.

## 3.4 PIC Subsystem

The PIC Subsystem will consist of four basic components: the microcontroller itself, the development tools used to program the microcontroller, the programmable circuit board that the microcontroller is attached to, and the various connections linking to the other subsystems and the power supply. Each of these components required ample research in order to determine the ideal parts to use for this project. The PIC Subsystem is required to tie together all of the other subsystems and to provide the logic that makes this project work. In other words, the PIC Subsystem needs to bend to the needs of the other subsystems. Because of these requirements, the primary concern when deciding which parts to use was flexibility. Outlined below are the various parts that were considered for each of the components of the PIC Subsystem.

### 3.4.1 Microcontroller

A microcontroller is an integrated chip that contains a CPU, RAM, ROM, I/O ports, and timers. Microcontrollers function as mini computers and can be found in basically any electronic device. If the device has a digital display or buttons, chances are that it contains a microcontroller. The great advantage to using a

microcontroller, as opposed to using a full-fledged microprocessor, is the reduced cost of parts and decreased power demands.

The microcontroller in this project is used to tie together all of the other independently functioning subsystems and to provide the overall functionality to the system that was desired. The microcontroller interacts with virtually every other component involved in the project, the primary consideration when choosing a microcontroller for this project was that it contained enough I/O ports to handle all of these interactions. Some other considerations included: cost, power, usability (how friendly it is to use by beginners), and memory. Several microcontrollers were considered: the MSP430G2231 by Texas Instruments, the AVR ATmega8 by Atmel, and the PIC16F877A by Microchip. Each of these microcontrollers is described below.

### 3.4.1.1 MSP430G2231

The MSP430G2231 microcontroller is developed by Texas Instruments. It is a 16-bit ultra low power microcontroller. The clock module can run at internal frequencies up to 16 MHz. The MSP430G2231 relies on RISC architecture. RISC stands for Reduced Instruction Set Computing. RISC architectures seek to boost performance by simplifying the CPU design, which enables faster execution for each instruction. The CPU is integrated with sixteen 16-bit registers. Four of the registers are reserved for the program counter, the stack pointer, the status register, and the constant generator. The remaining twelve registers are general-purpose registers. The MSP430G2231 contains two I/O ports. P1 is an 8-bit port, and P2 is a 2-bit port. A diagram of the pin configuration is provided below

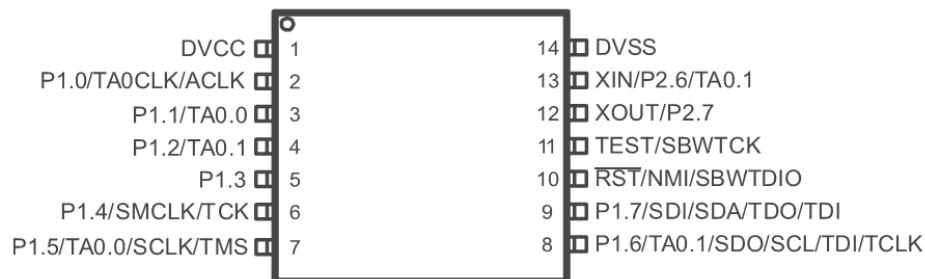

#### MSP430G2231 Pin Configuration

There are many advantages to developing a project with the MSP430G2231. The low cost makes it an ideal choice for projects with a low budget where every penny counts. Texas Instruments provides ample documentation for programming the MSP430G2231, which makes it easy to pick up for beginners. Texas Instruments also provides free software for programming the MSP430G2231.

The real glaring weakness in using the MSP430G2231 is the lack of I/O ports. For a project of this scale, where it is necessary to interact with three other independent subsystems, two ports simply were not going to cut it. It would have been possible to utilize multiple microcontrollers to make up for the MSP430G2231's lack of ports. However, it seemed like a better option to go with a different microcontroller in an effort to simplify the design.

### 3.4.1.2 AVR ATmega8

Atmel develops the AVR ATmega8 microcontroller. The AVR ATmega8 is a high-performance, low-power 8-bit microcontroller. It is capable of 16 MIPS throughput at 16 MHz. The AVR ATmega8, like the MSP430G2231, is based on RISC architecture. It contains many features including: 8K bytes of In-System Programmable Flash with Read-While-Write capabilities, 1K byte of SRAM, 512 bytes of EEPROM, and 32 general-purpose registers. All of the general-purpose registers are 8-bit registers. The AVR ATmega8 also contains twenty-three I/O lines in the form of three ports. Ports B and D are both 8-bit bi-directional I/O ports with internal pull-up resistors. Pull-up resistors are used to ensure that logic systems settle at expected logic levels. The remaining port, Port C, is a 7-bit bi-directional I/O port that also contains internal pull-up resistors. A diagram of the pin configuration is provided below.

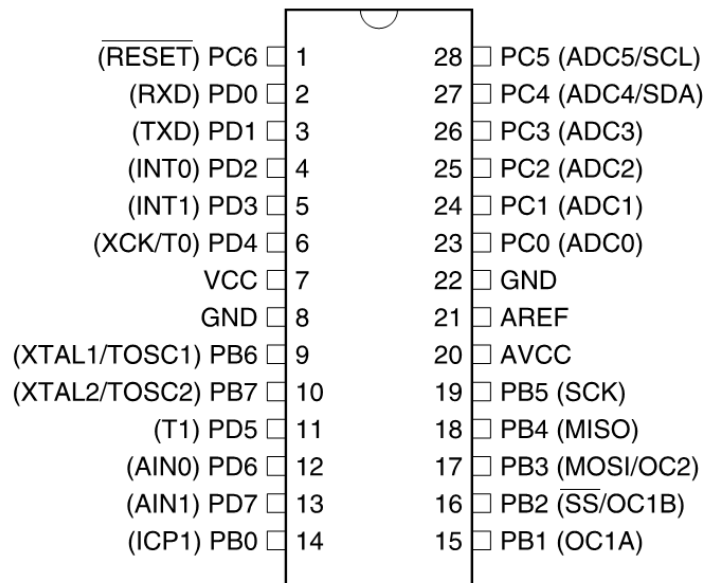

**AVR ATmega8 Pin Configuration**

At first glance, the AVR ATmega8 appeared to be the ideal microcontroller for this project. Each of the three I/O ports could be dedicated to providing interaction between the microcontroller and each of the three independent subsystems. The cost of the microcontroller is comparable to the MSP430G2231. All of the necessary software for programming the AVR ATmega8 is available for free from the Atmel website. Best of all, there is an active forum of users willing to help beginner programmers with any issues they may have.

However, there was still concern that the three I/O ports would not be enough. This project contains several LEDs that indicate the status of the system. Some of these LEDs are controlled by the individual subsystem that they belong to while others are independent of the individual subsystems. If each of the three I/O ports were dedicated to each of the subsystems, there was concern that it would be impossible to light up the independent LEDs.

### 3.4.1.3 PIC16F877A

The PIC16F877A microcontroller is developed by Microchip. The PIC16F877A contains a high-performance RISC CPU, which operates at 20 MHz clock input. Some of the features it includes are 8K Flash Program Memory, 256 bytes of EEPROM, and a unique register file map that can account for up to 129 general-purpose registers. The PIC16F877A also contains thirty-three I/O lines in the form of five ports. Port A is 6-bits wide and bi-directional. Port B is an 8-bit wide, bi-directional port that contains weak internal pull-up resistors. Port C is 8-bits wide and bi-directional. Port C pins have Schmitt Trigger input buffers, which allow for minor changes in input without affecting the output. Schmitt Triggers are typically used in noise reduction applications. Port D is an 8-bit wide, bi-directional port, which also contains Schmitt Trigger input buffers. Each pin of Port D is individually configurable as input or output. Port E has three pins, which are individually configurable as inputs or outputs and also contain Schmitt Trigger input buffers. A diagram of the pin configuration is provided below.

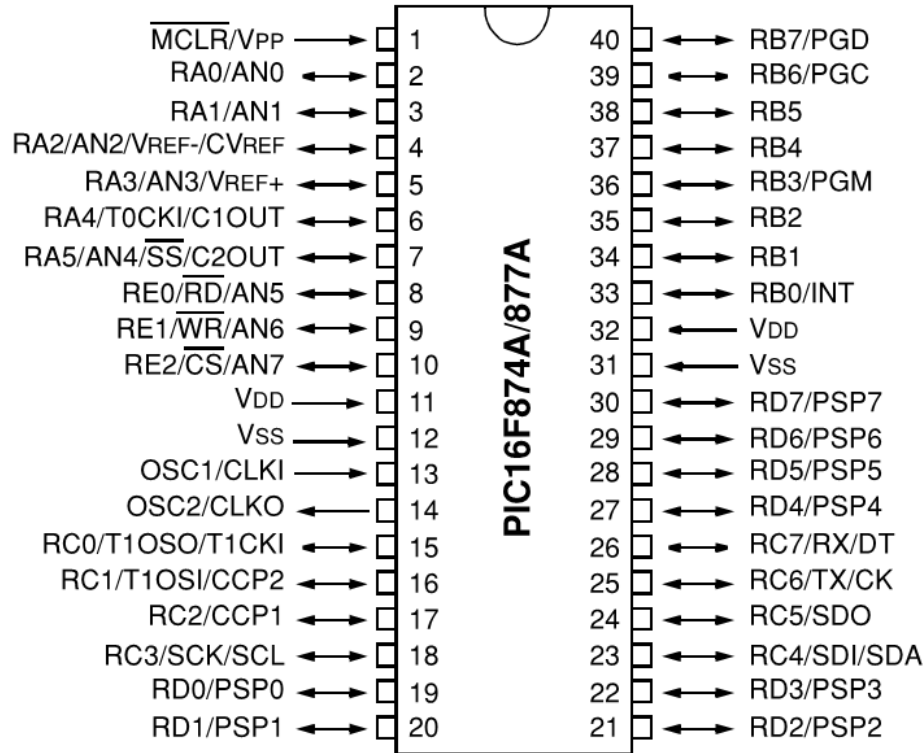

### PIC16F877A Pin Configuration

Like the other microcontrollers that were considered, the low cost of the PIC16F877A makes it very affordable. There is a wide variety of software available for programming the PIC16F877A. Microchip sells a rather expensive C compiler for programming their microcontrollers on their website, but there are several open source options as well. A simple Google search yields dozens of tutorials for beginner PIC programming. Most importantly, five I/O ports provide the flexibility necessary for a project of this scale.

There are literally thousands of different microcontrollers. It would be impossible to compare each and every one of them. With thirty-three I/O pins, the PIC16F877A provides enough flexibility to make it work for this project. It may not be the ideal microcontroller that provides optimal functionality for this application. Some of its I/O pins may not be used, but it will work.

## 3.4.2 Compilers and Others Development Tools

In order to provide functionality to the microcontroller, it needs to be programmed. The process of programming a PIC is often referred to as “burning.” A hex file is required for burning into the PIC. It is possible to program the hex file directly, but for the sake of simplicity, a compiler is often used to

generate the file from code written in a more user-friendly language. There are several C compilers available for programming PICs. Some of them are free, while others are quite expensive and provide extra features. Several compilers were considered for use in this project. The details of these compilers are provided below.

### 3.4.2.1 CCS PIC Microcontroller C Compiler

The CCS C Compiler provides many desirable features. This compiler utilizes device specific include files, which optimizes code generation depending on the specific PIC microcontroller that is being used. The compiler also contains over three hundred built-in functions for direct access to microcontroller hardware features such as on-chip data EEPROM, timers, and external memory busses. Built-in libraries are available for quickly implementing industry standard protocols for interface and communication such as USB and RS232. Additionally, the CCS C Compiler supports up to 56K instructions and 4K RAM for the PIC16F877A and other 14-bit opcode devices.

While these features would be nice to have, there is also a significant learning curve to utilize them efficiently. The time spent researching the various built-in functions and how to apply them to this project would far exceed the amount of time spent writing a function that performs a similar task specific to the needs of this project. These built-in functions would be useful for programming a wide array of projects, but they cannot be utilized effectively without much experience. Another deterring factor for this compiler was the cost. It is hard to justify spending one hundred and fifty dollars for all the bells and whistles when most of them would go unused and free alternatives exist.

### 3.4.2.2 Small Device C Compiler

The Small Device C Compiler (SDCC) is an open source, optimizing C compiler that targets many microcontrollers including the Microchip PIC16F series. SDCC includes an assembler and a linker based on ASXXX, which is also open source software. It includes microcontroller-specific language extensions, which allow for effective use of the underlying hardware as well. The Small Device C Compiler includes a variety of standard optimizations such as loop optimizations; dead code elimination; and jump tables, as well as microcontroller-specific optimizations, including a global register allocator. Additionally, SDCC supports a full range of data types found in the C language, including char, short, int, long, and float.

While it is unclear whether or not many of these features will be utilized in programming the microcontroller for this project, it is nice to have them available. The main appeal for this compiler is the fact that it is free and does not place any

limits on the size of code that it supports. There is also quite a bit of documentation available for installing the compiler, and many tutorials are available online for compiling code via the command line interface. There are dozens of C compilers that are compatible with the PIC16F877A; however, few of them are free. Of the compilers that are free, many only support up to 1K or 2K of code. SDCC is both free and places no limit on the amount of code that it supports.

### **3.4.2.3 PICkit 2 Microcontroller Programmer**

As mentioned earlier, a programmer is needed to “burn” the hex file that the compiler generates into the microcontroller. The programmer consists of software that transmits the file from a computer to the microcontroller and hardware that provides an interface between the computer and the microcontroller. There are dozens of cheap do-it-yourself programmers available, but many of them are targeted at hobbyists who already have a vast understanding of how to program a microcontroller. For this reason, it was decided to buy a programmer that would be more forgiving to use by a beginner.

The PICkit 2 Microcontroller Programmer is developed by Microchip, the same company that develops the PIC16F877A used for this project. The programmer package contains the PICkit 2 Development Programmer/Debugger, the PICkit 2 Programming Software, a USB cable, and lessons for programming PIC microcontrollers. The programmer uses a USB mini-B connector to connect to a computer and a 6-pin programming connector to connect it to the target device. The 6-pin programming connector accepts 0.025” square pins with 0.100” spacing. In order to connect the programmer to the microcontroller, it will be necessary to mount a 6-pin male header connector on the printed circuit board.

### **3.4.2.4 PIC16F877A Development Board**

A custom printed circuit board will be built for use with the final functioning project; however, a preconfigured development board will be purchased in an effort to quickly develop a working prototype. The main concern in choosing a development board was flexibility. Development boards are often designed with a specific function in mind. Finding a development board to fit the specific needs of this project was highly improbable, so a simple development board that could be used in unison with a breadboard for increased adaptability was chosen.

The PIC16F877A Development Board is powered by a 6-12V DC power source. The board comes equipped with a PIC16F877A microcontroller. The development board also provides eight LEDs to show I/O status, one RS232 port for connection with a computer, a power switch, and a reset switch. The board also provides an ICSP Program Emulator Interface that will connect to the PICkit

2 Microcontroller Programmer that will be used to program the microcontroller. Perhaps most importantly, all pins are taken out on IDC connectors to make them available for further connections. This will allow the development board to be coupled with a breadboard in order to provide the exact connections that are required for this project.

### **3.4.3 Printed Circuit Board**

A printed circuit board is necessary to facilitate communication between the PIC subsystem and every other aspect of the project. The microcontroller will be mounted on the printed circuit board, which will electrically connect the microcontroller to other electronic components via conductive pathways. Electrical components are attached to the surface of the printed circuit board by soldering. The conductive pathways that connect each of the electrical components are built into the board based on a schematic diagram that is provided to the printed circuit board manufacturer at the time of purchase. There are multiple resources available for creating custom printed circuit board designs. Several resources were considered for use in this project. The specifications of each resource considered are provided in detail below.

#### **3.4.3.1 Sunstone Circuits**

Sunstone offers a wide array of printed circuit board design services. The most applicable option for this project is the ValueProto design service. ValueProto boards are built within ten days, are produced in small quantities, and offer two layer prototypes for as little as twenty-eight dollars. Sunstone ValueProto boards are built to file as provided at the time of purchase. Sunstone supports a variety of design software, including the free PCB123 Design Software provided by Sunstone and the ever-popular EAGLE PCB software. Additional specifications of the Sunstone ValueProto boards include: 0.062" board thickness, support for up to twelve by fourteen inch board sizes, twenty-three available hole sizes, LPI green solder mask, and white legend on the top side of the board. Sunstone also provides customer service everyday of the year at any hour via email communication.

The most appealing aspect of using a Sunstone printed circuit board is the support for the EAGLE PCB software, which is made available free of charge by the university. There are a wide variety of tutorials available for using the EAGLE software, something that cannot be said for most of the schematic design software available for free. However, the price of the board itself simply does not make this a justifiable option. Only the most simplistic designs are available at the advertised price of twenty-eight dollars. As the size of the board increases, the cost of the board rises at an almost exponential rate. This project requires quite a few electronic pieces to be mounted on the printed circuit board. Between

the 40-pin microcontroller and the various terminal blocks that will allow communication with the other subsystems, it is not reasonable to suspect that Sunstone Circuits will provide a cost-effective printed circuit board for use with this project.

### 3.4.3.2 PCBexpress

PCBexpress also offers a large range of printed circuit boards with many different options available. PCBexpress offers two separate options for 2-layer boards. The first option, E1, excludes the silkscreen and solder mask in an effort to reduce production time and costs. These boards ship the day after they are ordered. The second option, E2, is more applicable to this project. E2 includes the silkscreen and solder mask, which are considered essential parts of the board for this project. E2 boards cost a bit more to account for the extra production costs, but they also ship fairly quickly, only two days after the order is placed. Additional specifications of the PCBexpress E2 boards include: tin lead or silver board finishes, support for up to one hundred and sixty-eight square inch board sizes, twenty-three available hole sizes, and a legend on the top side of the board. PCBexpress also provides 24/7 customer service everyday of the year.

The best thing that PCBexpress has going for them is their support for a wide variety of CAD system design tools. They will accept designs from just about any CAD software available for circuit design. The turnaround time between ordering the printed circuit board and receiving it is also significantly lower than any other manufacturer offers. One additional perk to ordering through PCBexpress is the inclusion of free shipping via UPS ground. Unfortunately, free shipping makes little difference in the total cost of the printed circuit board. A lot of two, nine square inch boards costs an astounding one hundred and thirty-nine dollars, and single board options are not available. The cost per board does drop a bit as more printed circuit boards are ordered, but only a single board is needed for this project. PCBexpress appears to target companies that need to produce multiple identical boards for a product rather than individuals who only need a single board.

### 3.4.3.3 ExpressPCB

ExpressPCB, like many of the printed circuit board manufacturers, has quite a few different options to choose from. The least expensive option offered by ExpressPCB is the MiniBoard Service. The MiniBoard Service provides the same high quality printed circuit boards as other manufacturing services, but the boards are only offered in a fixed size and quantity. By limiting the size of the board to 3.8 by 2.5 inches and restricting orders to three boards, ExpressPCB is

able to offer the printed circuit boards at a very low price. The MiniBoard service offers two separate options for 2-layer printed circuit boards. The first option, the Standard Miniboard, is the cheapest option at fifty-one dollars. Standard Miniboards do not include the solder mask or silkscreen layers. These boards ship the next business day after they are ordered. The second option, the MiniBoardPro, is also a great deal at seventy-five dollars. These boards include both the solder mask and the silkscreen that are absent from the Standard MiniBoards. MiniBoardPros ship two business days after they are ordered to account for the additional production time. ExpressPCB also offers customer service via email communication.

ExpressPCB provides free CAD software that is used to design both the circuit schematic and the board layout. ExpressSCH is used to design the schematic, and ExpressPCB is used to design the printed circuit board layout. ExpressPCB claims that using their software makes designing circuit boards simple for the beginner and efficient for the professional. In addition, the learning curve for using the software is relatively short due to its familiar interface. It is as simple as placing components on the board, positioning them in the desired locations, and drawing the traces to make the necessary connections. The restrictions on the size of the board are a cause for concern though. 3.8 by 2.5 inches should provide enough wiggle room to fit everything that is needed on the board, but it is unclear at this point if a bigger board would be needed. Also, the requirement to purchase three boards is a bit much. Only one board is needed for the project, although having three could be nice in case one is damaged while mounting the components.

### **3.4.3.4 Advanced Circuits**

Advanced Circuits has a unique opportunity available for engineering students that none of the other printed circuit board manufacturers offer. Advanced Circuits offers 2-layer circuit boards at a cost of thirty-three dollars each. This special usually requires the purchase of at least four printed circuit boards, but students qualify for the special with no minimum purchase. The specifications of these boards are similar to many of the other printed circuit board manufacturers. The boards require a minimum of 0.006" line spacing and a minimum of 0.015" hole size. All holes are plated. The board includes a green LPI solder mask and a white legend on one or two sides. Perhaps most importantly, the thirty-three dollar special applies to boards up to sixty square inches in size. This should be more than enough space to contain the various electrical components that will be mounted on the printed circuit board for this project. There is typically a five-day turnaround between when boards are ordered to when they ship, but many orders ship ahead of schedule. Additionally, twenty-four hour tech support is available via telephone.

Advanced Circuits also offers their own free CAD software for designing circuit boards like most manufacturers do. PCB Artist integrates schematic design tools and printed circuit board layout tools into a single application and is comparable to many full-featured CAD design tools without the ridiculous price tag for a single license. Advanced Circuits also provides a sequence of tutorial videos and various other guides for first time users. Perhaps the most impressive service that Advanced Circuits offers is their complimentary file check. When the design files are completed, Advanced Circuits provides a free design file report, which will provide details on any problems in the design that may affect manufacturability. Utilizing the free design file report will ensure that the files meet all fabrication specifications. This free file check is ideal for first time designers. Advanced Circuits appears to be the ideal manufacturer to purchase a single printed circuit board from considering the low cost, relatively quick turnaround time, and beginner-friendly tools available.

### **3.4.4 Communications and Power Supply**

Since all of the subsystems in this project are designed to function independently, there is no need to clutter the printed circuit board with excessive electrical components other than those that are necessary to provide communication with the other subsystems. A few capacitors and resistors will need to be utilized to regulate the voltage and current transmitted to each subsystem, but the schematic diagram will be relatively simple. One of the major decisions that had to be made for this section of the project was whether to provide power to the microcontroller through a powered USB port or employ an external power source. Both options were researched extensively, and it became clear that one of them was far more advantageous to use than the other one was.

#### **3.4.4.1 Terminal Blocks for Communications**

Multiple methods of communication were considered throughout the design phase of the project. At one time it was thought that two RS-232 connectors would be needed to provide communication with the speaker recognition system and the card read system. However, as the project was further researched, it became clear that all of the necessary communications could be achieved via surface-mounted terminal blocks. Terminal blocks are used to connect and disconnect complicated devices more easily. Two varieties of terminal blocks are available: screw-in and plug-in. Screw-in terminal blocks accept bare wires, which are wrapped around a tightened screw to form the necessary connection. Plug-in terminal blocks require a specific male terminal that plugs into a female receptacle to form the necessary connection. Screw-in terminal blocks will be used in this project due to their increased flexibility. The terminal blocks will be mounted on the surface of the printed circuit board. The board itself will include

traces that connect each of the terminals to the desired port on the PIC16F877A microcontroller.

### 3.4.4.2 Powered USB

Powered USB provides the standard USB communication signals as well as an additional wire pair for power. Powered USB comes in five, twelve, and twenty-four volt varieties. Five volts is a perfectly acceptable operating voltage for the PIC16F877A microcontroller. Typically, five hundred milliamps of current is available through a powered USB port. This exceeds the maximum current of two hundred and fifty milliamps that the microcontroller will accept at the  $V_{DD}$  pin, but it would be easy enough to design the circuit in such a way that the current at the  $V_{DD}$  pin would be within an acceptable range. The primary advantage to providing power to the microcontroller via powered USB is that it eliminates the need for an external power supply. This was very appealing at first; however, this advantage quickly disappeared as the needs of each of the other subsystems were further developed.

The main drawback to this approach was the fact that the circuit board would have to remain connected to a computer while demonstrating the functionality of the project. The circuit board needs to be connected to a computer while programming the microcontroller anyway, but it could be disconnected after programming was complete if an external power supply was used. While this would be quite inconvenient, it would not make using powered USB as a power source completely infeasible. When coupled with the fact that an external power supply would be needed to provide power to the other subsystems anyway, powered USB turned out to be quite a bit less ideal than it initially appeared to be. Any remaining reasons to supply power to the circuit board via a powered USB port vanished when it became clear that a five-volt power supply would be required for the speaker recognition subsystem.

### 3.4.4.3 External Power Supply

Using an external power supply provides several advantages over powered USB. The most significant advantage is the flexibility. External power supplies are available in all kinds of configurations and are not limited to five, twelve, and twenty-four volt varieties as powered USB ports are. External power supplies can also be configured more easily to ensure the right amount of current is flowing to the microcontroller. An external power supply also increases portability. There is no need to leave the circuit board connected to a computer for power after the microcontroller has been programmed. Perhaps most importantly, using an external power supply is simply more convenient. Since a five-volt power supply is already required for use by the speaker recognition subsystem, it would be

foolish not to piggyback off of that connection and also use it as a power supply for the microcontroller.

The PIC16F877A will accept voltages in the range of 4.0 V to 5.5 V with frequencies as high as 20 megahertz. The microcontroller will connect to the five-volt power supply via a terminal block, the same way it connects to each of the subsystems. This will provide more versatility than if the power supply were mounted on the board directly. It makes replacing the power supply easier in case it malfunctions. The terminal block will contain a total of four terminals. Two of these terminals will supply power and ground signals directly to the microcontroller. The other two will be linked to the incoming signals and function as outgoing power and ground wires for supplying power to the speaker recognition subsystem. This setup makes using an external power supply to power the microcontroller the ideal choice.

## 3.5 Architectures and Related Diagrams

Presented in figure 3.5 is the generalized block diagram describing the overall operation of the Security Hands Free Entry System. The system is split up into its separate main functions. The subsystems are all fed into the PIC microcontroller where they are turned into a digital representation and processed using C code. Each of the subsystem, although shown as a simple block, represents detailed circuits that are too confusing to show in a single schematic representation. In the previous research section, there are a lot of ways to design each module subsystem. The following sections will be discussed in great detail about actual design for each of subsystem modules. In being a group project, each person is assigned an individual subsystem to both research functionality and come up with a possible design. The core functionality of the Security Hands Free Entry System is around the PIC microcontroller. This is where all the commands will be done and output to the door.

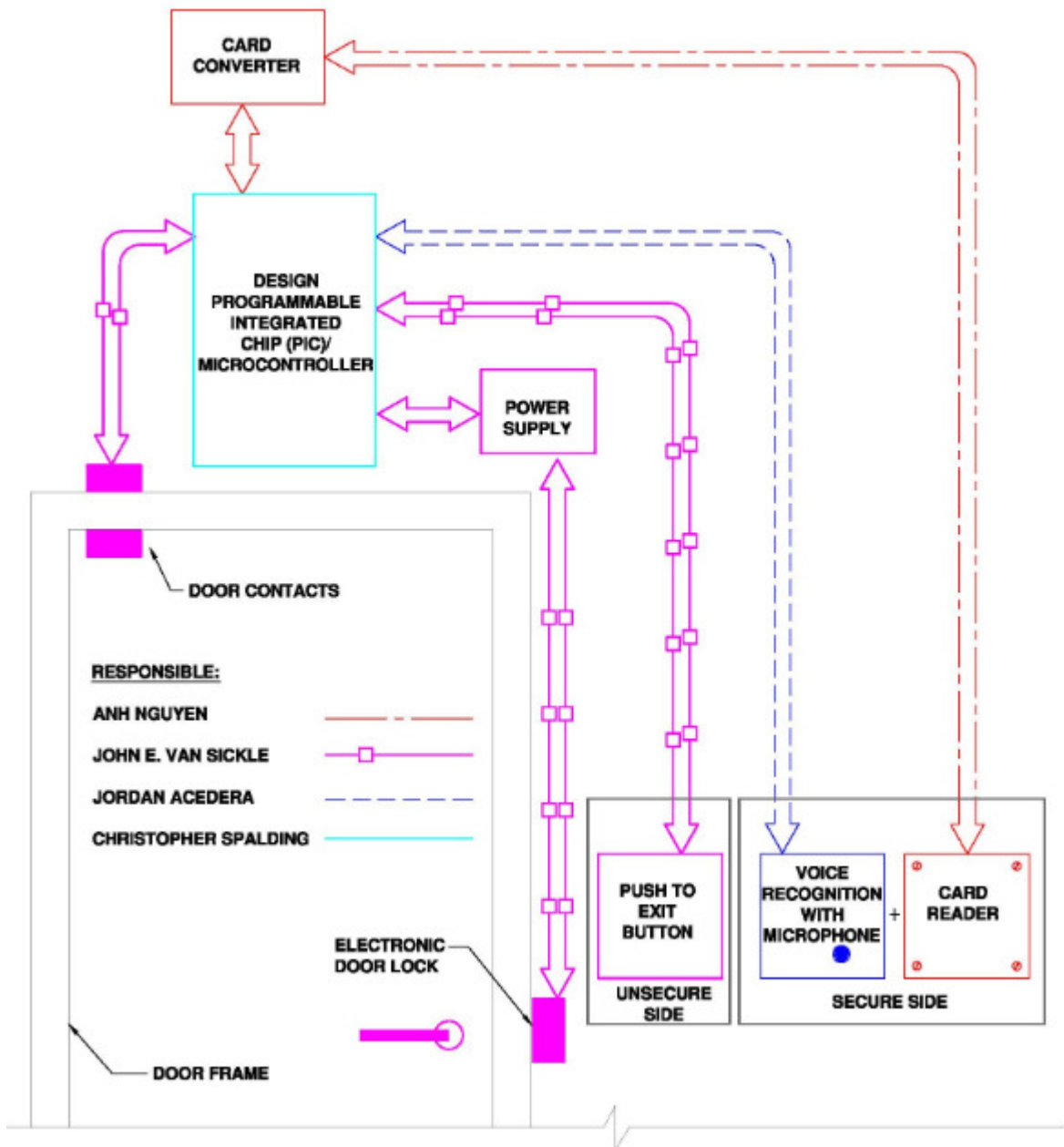

**FIGURE 3.5: OVERALL SECURITY HANDS FREE ENTRY SYSTEM**

## 3.5.1 Card Access Control Reader Subsystem Diagrams

Figure 3.5.1.1 below is a card access control subsystem. In summary, the card reader will continuously look for the RFID tag. Reader converter detects the selected RFID Tag in range. When that tag is in range with the right identification the PIC will send out a signal to card reader to change LED stage in junction with other conditions from the speaker recognition before to release the door.

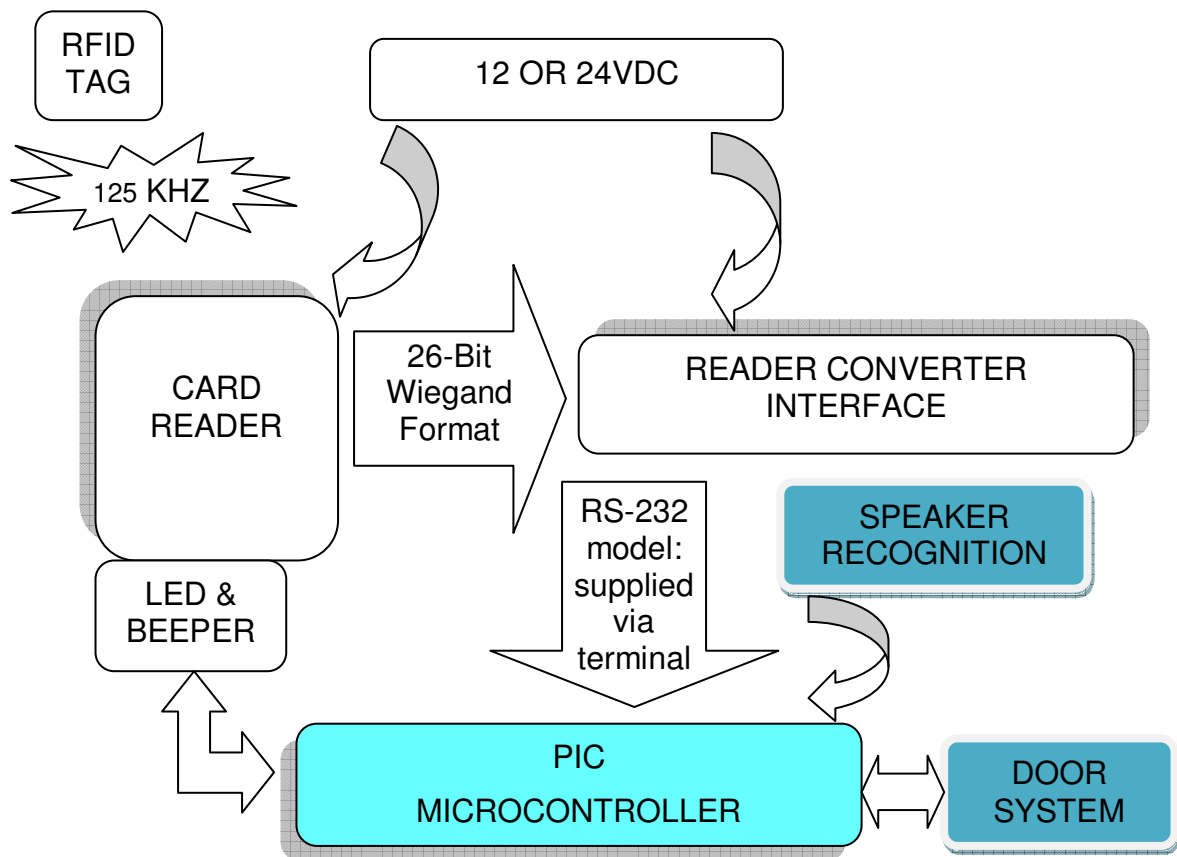

**FIGURE 3.5.1.1: CARD READER SUBSYSTEM BLOCK DIAGRAM**

The figure 3.5.1.2 below is complete pin connection for card access control subsystem. For the purposed of the project, from the reader the green wire and white wire connect to data 0 and data 1 in reader converter. Brown wire and orange wire control LED of the reader from PIC. R232 and T232 pins from the reader converter to PIC. A common signal ground is defined as a voltage reference that is common to both the reader and the reader converter. The voltages for the data outputs are referenced from the power supply ground located at the reader. The voltage measured for the power to the reader is referenced from the power supply return connection location at the reader, not at the source of the power.

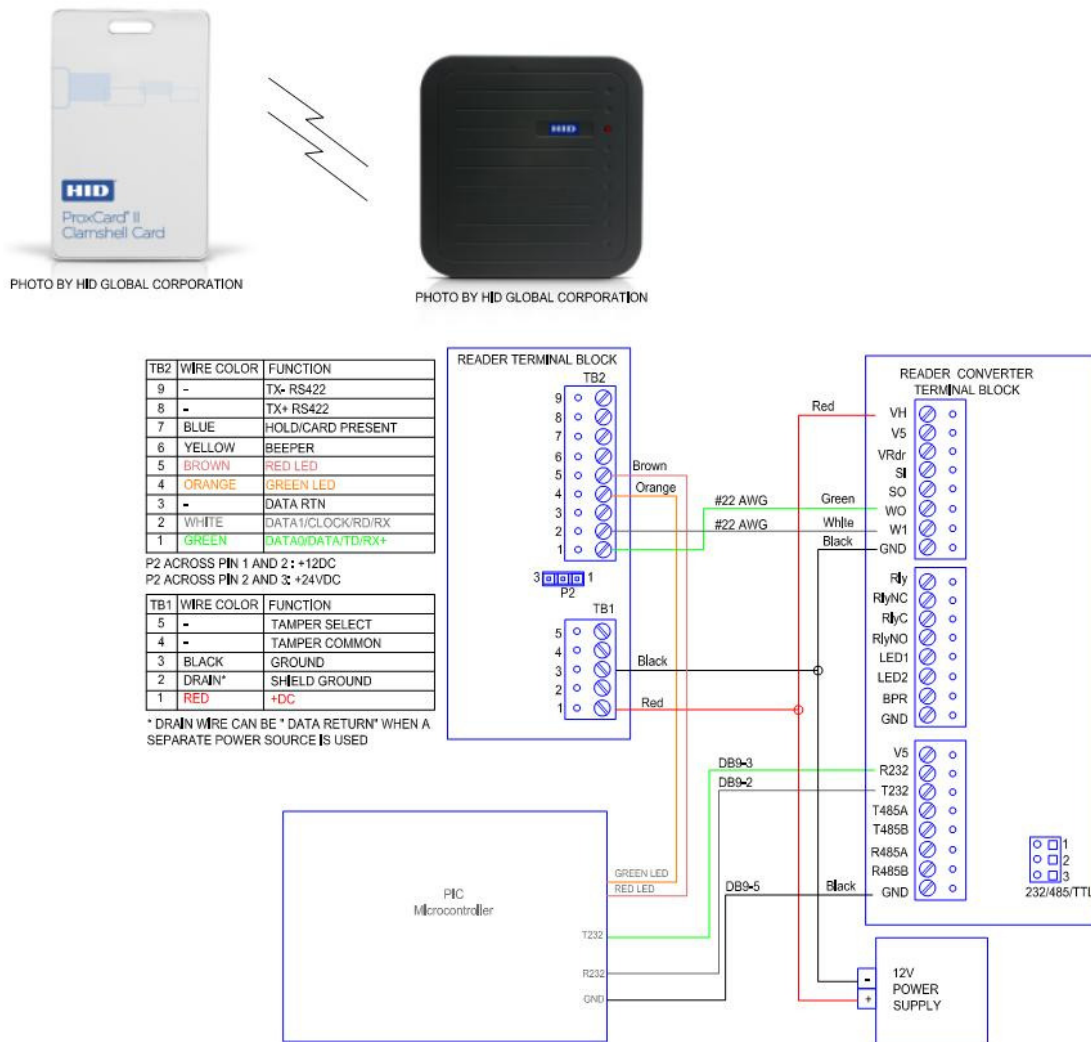

**FIGURE 3.5.1.2: CARD READER SYSTEM WIRING DIAGRAM**

Figure 3.5.1.3 is shown sample of Wiegand reader converter configuration Utility interface from RFIdeas.

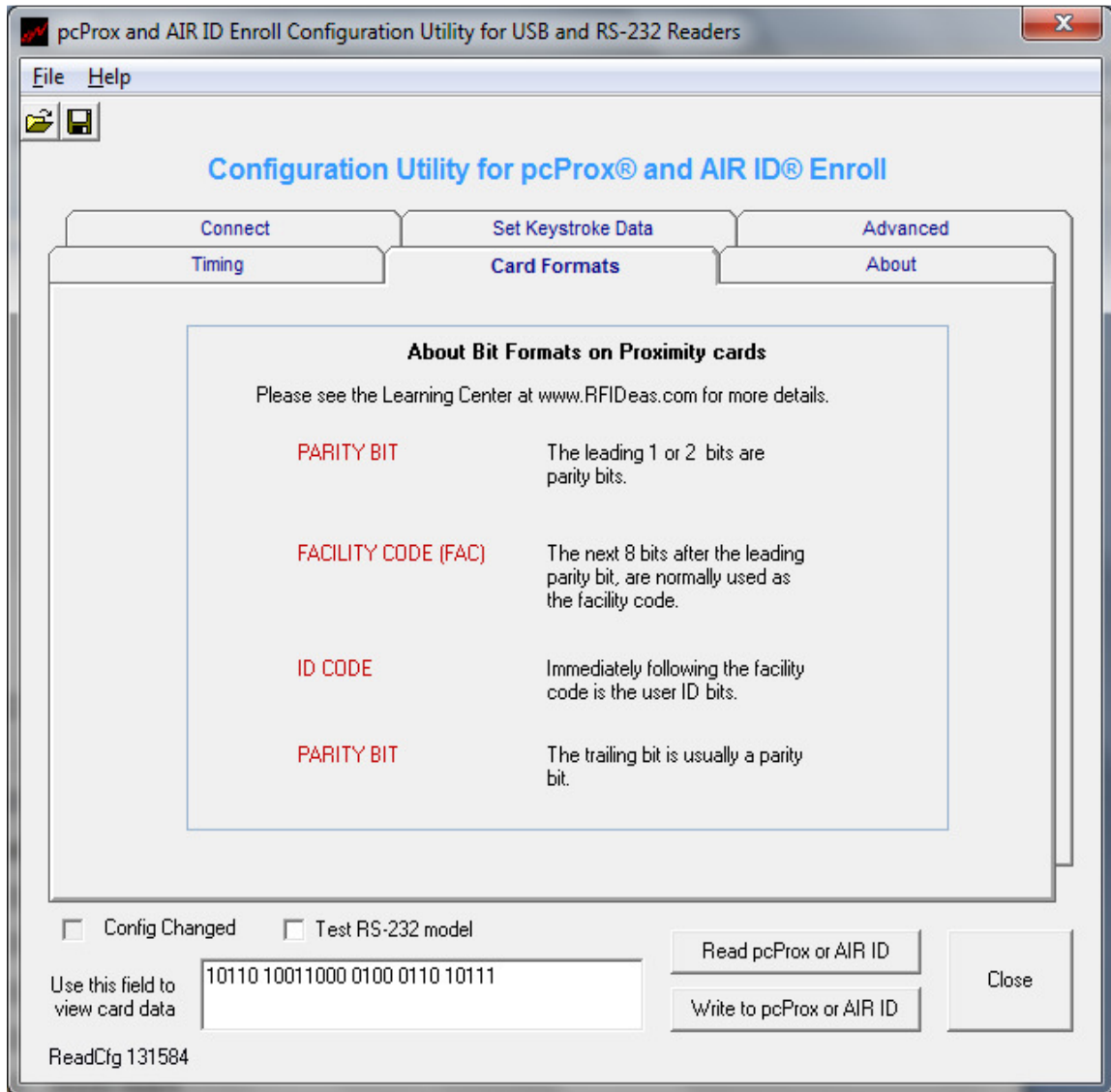
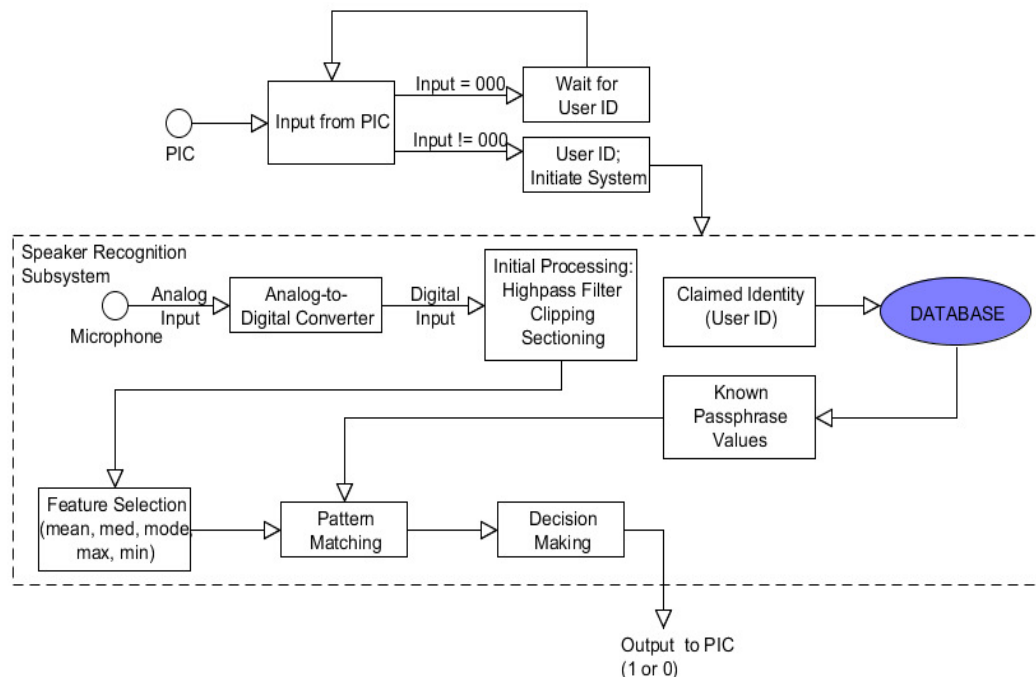

**FIGURE 3.5.1.3: WIEGAND READER CONVERTER INTERFACE**

## 3.5.2 Speaker Recognition Diagrams

Here is a brief explanation of the procedure used by the speaker recognition subsystem, illustrated in Figure 3.5.2.1

While the speaker recognition subsystem is awaiting a User ID input from the PIC subsystem, it will be in a sleep state. During this state, the speaker recognition subsystem will be receiving a constant "000" input from the PIC. When the input from the PIC is not "000", this will constitute the User ID for the speaker recognition subsystem to obtain the user's voice profile from the database. Once the voice profile is obtained from the database, the speaker recognition subsystem will activate the microphone for recording the user's passphrase. The recorded input will then be trimmed and filtered to remove unwanted noise. Feature selection will then be performed by extracting the Mel Cepstral Frequency Coefficients from the passphrase sample. These features will be compared to those found in the database with a Hidden Markov Model pattern matching algorithm. If a match rate above a certain threshold is obtained, then the speaker recognition subsystem will return a 3-bit confirmation code to the PIC. However if the match rate is below that threshold, the speaker recognition subsystem will return a "000" to the PIC indicating a match failure.



**FIGURE 3.5.2.1: BASIC OPERATION OF SPEAKER RECOGNITION SUBSYSTEM**

### 3.5.3 Electronic Door Diagrams

The system below is made up of commercially available components and allows for the opening of a door without the turning of the knob. The parts are summarized and identified on the diagram below. Utilizing 120 volts with low current draw, a wall receptacle mounted low voltage power supply will provide 12 volts ac power as a source for the circuit. This 12 volts ac acts as an input to the circuit board that rectifies it to 12 volts dc and then controls the expected run time of the door strike. A timer resident onboard the circuit administers the voltage for an adjustable period of time in seconds. The prompt to start the clocking down of this power is given by the closing of normally open contacts located on either the push to exit button or more commonly by the pair provided from the processor. Either device will allow the door to go to the unsecured state. Upon change of state of the door (closed to open, vice versa) the status will communicated back to the processor via a normally open pair of contacts residing in the door prox or status switch. This information will be utilized by the processor to insure the door has reverted back to the fully closed position.

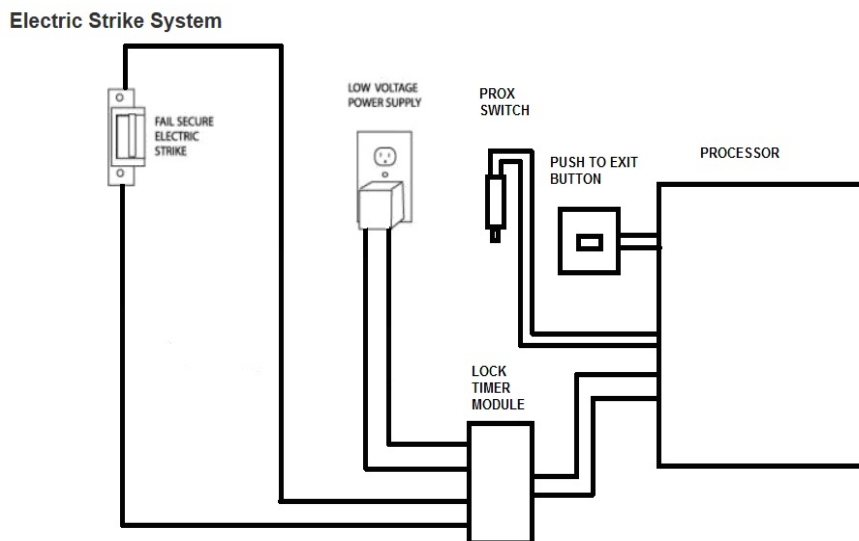

**FIGURE 3.5.3.1: ELECTRIC DOOR SYSTEM BLOCK DIAGRAM**

Interconnection of components will be accomplished using insulated conductors sized per current draw and applicable safety codes. Utilizing this wire with insulation designed for this application, the wiring together of these devices shall be in accordance with the drawing below. As noted, the power comes into the controller board from the wall mounted power supply on the push to connect terminals located on the upper left hand corner. The output of the board will be connected from terminal board connection TB-1 and TB-2 to the electric strike. Note the open door timer located on the right hand side of the board. This potentiometer shall be utilized to control the entrance period allowing the user to enter the secured area. CCW rotation will extend the time – CW rotation to minimize the amount of time the door to remain unsecured. Connection to the Control of this actuation shall be thru TB-5 and TB-6 connected to both the push to exit pushbutton and the processor (see PIC Assembly). A N.O. status switch will not be connected to the controller board but instead will provide a N.O. state directly to the processor. As integration with this processor or any processor takes form, additional optional circuitry will be included (spares if not needed).

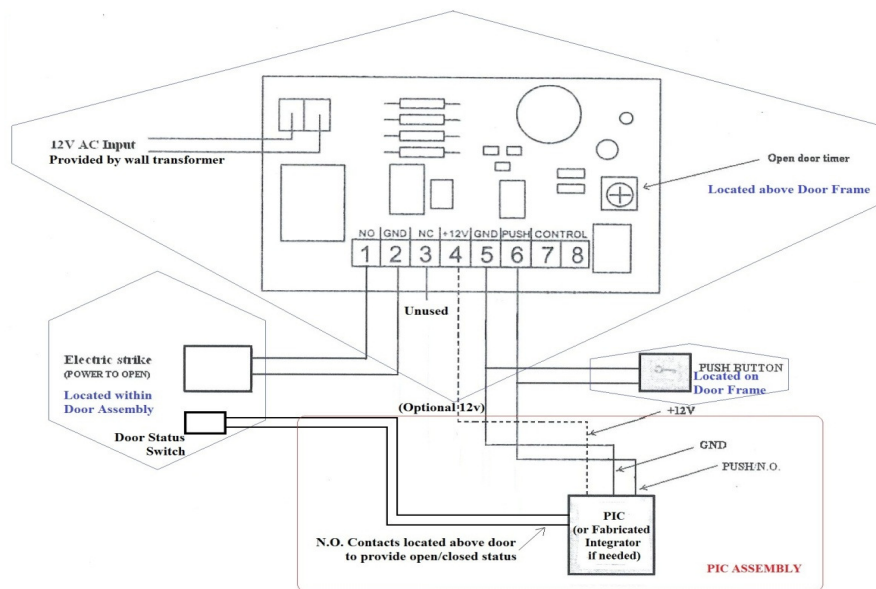
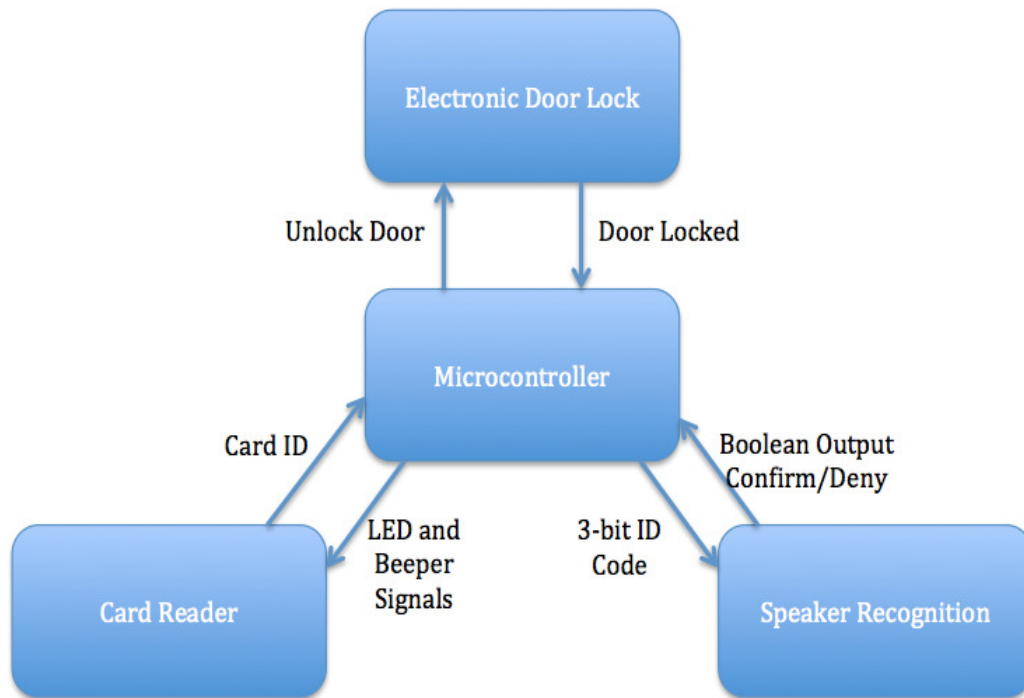

**FIGURE 3.5.3.2: ELECTRIC DOOR SYSTEM WIRING DIAGRAM**

## 3.5.4 PIC Diagrams

### 3.5.4.1 Block Diagram

Figure 3.5.4.1 provides a high level view of the communication that occurs between the microcontroller and the three other subsystems without identifying the specific connections that facilitate that communication. The microcontroller shares input and output connections with each of the three subsystems. A detailed description of these connections including exact pin numbers can be found later in this document. A brief overview of the communication with each of the subsystems is provided here for convenience.



**FIGURE 3.5.4.1 PIC BLOCK DIAGRAM**

The microcontroller accepts the identifying information for the card from the card reader subsystem. It uses this information to determine whether or not a valid card is in range of the receiver. The microcontroller shares additional connections with the card reader subsystem to control the card reader's status LEDs. The card reader includes a red LED and a green LED that are lit up and put out in accordance with the status of the system.

The microcontroller provides the speaker recognition subsystem with a three-bit signal that corresponds to the voice profile that is stored for the user whose card is in range of the receiver. When the speaker recognition subsystem receives this

signal, it begins waiting for voice input from the user. The speaker recognition subsystem will analyze the voice input and compare it to a stored sample of the supposed user's voice. It will then communicate back to the microcontroller indicating whether or not a match was made.

When the microcontroller receives confirmation of a positive voice match from the speaker recognition subsystem, it will proceed to communicating with the electric door latch subsystem. The electric door latch subsystem is almost entirely self-contained. The only information it needs from the microcontroller is a signal to indicate the door should be unlocked. The electric door latch subsystem will then unlock the door and subsequently lock it again after a period of time. The microcontroller will be notified when the door is locked again through its connection with the door status switch contained within the electric door latch subsystem.

### 3.5.4.2 State Diagram

Figure 3.5.4.2 provides a look at the various states that the system can take and the actions necessary to proceed through them. There are five basic states of the system: waiting for card, waiting for voice, card and voice confirmed, door unlocked, and door locked. The function of the microcontroller will vary depending on the state of the system. Certain actions will be expected when the system is in one state, while those same actions will be completely ignored by the microcontroller if they occur while the system is in another state. A brief description of the five states of the system as well as the actions that facilitate changes in state is provided below.

The “Waiting for Card” state is also referred to as the idle state. This is the state of the system when it is not currently in use. The system will remain in the “Waiting for Card” state until a card comes in range of the receiver, and the card reader subsystem transmits the card identification to the microcontroller. If the card's identification is not among the short list of cards to be used by the system, the card will be identified as invalid. No state change occurs when an invalid card is in range of the receiver. However, if the card's identifying information is found in the system, the card will be deemed valid. When a valid card is in range of the receiver, the system will proceed to the next state in line, the “Waiting for Voice” state.

The “Waiting for Voice” state is the second possible state of the system. During this state, the microcontroller is communicating with the speaker recognition subsystem. If the valid card leaves range of the receiver at any time during this state, the system will revert back to the “Waiting for Card” state. As long as the card remains in range of the receiver, the state of the system will depend on the output of the speaker recognition subsystem. The system will remain in the “Waiting for Voice” state until a positive voice match can be made. No state

change will occur for a negative voice match. When a positive voice match is made without the card first moving out of range of the receiver, the system will then proceed to the next state in the sequence, the “Card and Voice Confirmed” state.

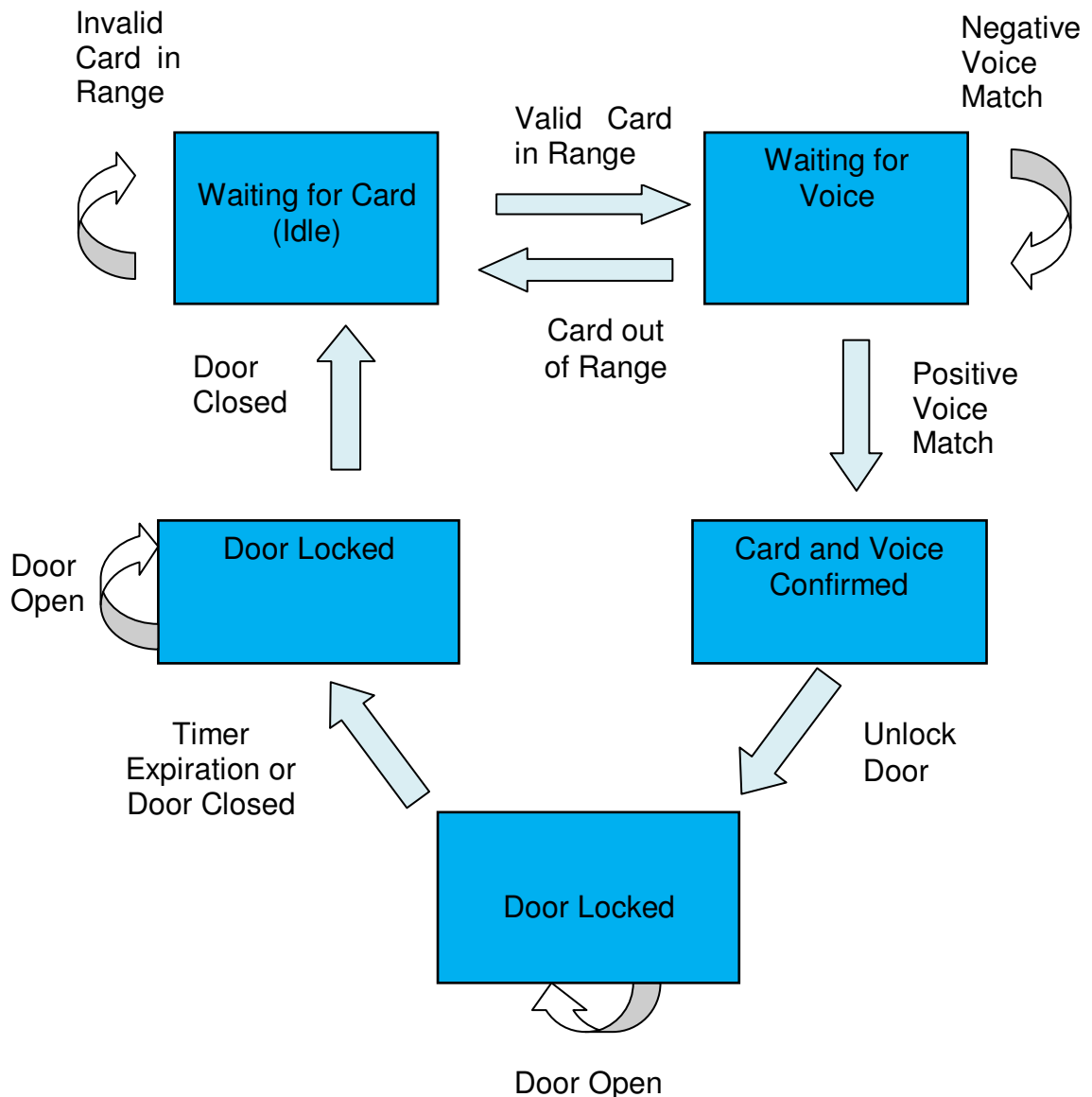

**FIGURE 3.5.4.2 PIC STATE DIAGRAM**

The “Card and Voice Confirmed” state is more of a transitional state than a traditional state that requires an action from the user. The “Card and Voice Confirmed” state initiates communication with the electric door latch subsystem and proceeds almost immediately to the “Door Unlocked” state. There is a possibility that the system can get stuck in this state if the electric door latch

subsystem malfunctions and fails to unlock the door. The system has been designed under the assumption that the hardware will function perfectly, although this is not necessarily the case during real-world experience. The possibility for error has been acknowledged, but addressing it would be beyond the scope of the project.

The “Door Unlocked” state is the state of the system during which the user is expected to walk through the doorway. The system will remain in this state for a set period of time or until the door is first opened and subsequently closed. If the door is never opened, the system will proceed to the “Door Locked” state when the timer expires. The timer begins counting down as soon as the system enters the “Door Unlocked” state. It does not wait for the door to first be opened. If the door is opened, the system will still proceed to the “Door Locked” state when the timer expires, but the change of state can be expedited by closing the door before the timer expires.

The “Door Locked” state is the final state before the system returns to the initial “Waiting for Card” state. The inclusion of this state is simply to check and make sure the door is closed. If the system proceeds from the “Door Unlocked” state to the “Door Locked” state through the action of closing the door, the system will confirm that the door is closed and proceed to the “Waiting for Card” state. If the system proceeds from the “Door Unlocked” state to the “Door Locked” state through the action of timer expiration, it is possible that the door has remained open. There is no use proceeding to the “Waiting for Card” state if the door is already open. Therefore, the system will remain in the “Door Locked” state as long as the door remains open and will only proceed to the “Waiting for Card” state when the door has been closed. When the system returns to the “Waiting for Card” state, the system will cycle through the states again as the necessary actions are performed.

## 3.6 Operation Mode

Any home/office lock or security system inevitably has some ethical considerations associated with it. Is the product 100% reliable? It can't unlock when it is not supposed to and it needs to unlock if someone inside wants to leave. In the security world, people look at any little issue to make the system break, not working properly. There are several considerations how the security hands free entry system can operate rather just open and closed the door. For our project it can be complicate but these operation mode might be useful for implement in the future project. For convenience we are going to call the security hands free system as SYSTEM. The SYSTEM can be set up in several LOCK modes and the change need to take effect after the next time zone change.

Card Only - The LOCK is set to be opened with a card only or by a Reader Access

Unlocked - The LOCK is unlocked.

First Card Unlock - The first valid badge that uses the reader unlocks the LOCK. Thereafter, the LOCK remains unlocked either until an authorized credential is presented twice within six (6) seconds or it exits First Card Unlock mode to another mode that requires the LOCK to be locked. The LOCK can be forced to exit First Card Unlock mode, either automatically based on a time schedule, or as commanded from the SYSTEM.

Blocked - When a LOCK is in the Blocked mode it can remain locked for all cardholders except those with blocking override privileges, or Secured or Unsecured cards. The LOCK shall be able to be put into or taken out of Blocked mode by presenting a Blocking card. A LOCK can only be placed into Blocked mode when the LOCK is in Card Only, Unlocked, or First Card Unlock mode. After exiting the Blocked mode the LOCK can exit into Card Only mode.

Secured - In Secured configuration the LOCK can remain locked until it is transitioned to a new mode. During Secured mode, no card shall be granted access. Automatic changes do not apply when the LOCK is in Secured mode. Lock can enter Secured from any other mode based on a command from the SYSTEM via WAP (Wireless Access Point), or a presented authorized Secured card. The LOCK shall enter Secured mode upon the next heartbeat if initialized from the SYSTEM via a WAP. Lock can exit Secured mode based on a command from the SYSTEM via WAP, a presented authorized Secured card, or a presented authorized

Unsecured card – in this case the LOCK can enter the unsecured mode. The LOCK can exit Secured mode upon the next heartbeat if initialized from the SYSTEM via a WAP. When the LOCK exits the Secured mode because an authorized Secured card was presented, it will always enter Card Only mode.. When the LOCK exits the Secured mode because of a command from the SYSTEM, it shall enter the new mode that was requested in the command.

Unsecured - In the Unsecured configuration the LOCK shall remain unlocked until it is transitioned to a new mode. Automatic changes do not apply when the LOCK is in unsecured mode. LOCK shall enter Unsecured from any other mode based on a command from the SYSTEM via WAP, or a presented authorized unsecured card. The LOCK can enter unsecured mode upon the next heartbeat if initialized from the SYSTEM via a WAP. LOCK can exit Unsecured based on a command from the SYSTEM via WAP, a presented authorized unsecured card, or a presented authorized Secured card – in this case the LOCK can enter the Secured mode. The LOCK can exit unsecured mode upon the next heartbeat if initialized from the SYSTEM via a WAP. When the LOCK exits the unsecured mode because an authorized unsecured card was presented, it will always enter Card Only mode. When the LOCK exits the unsecured mode because of a command from the SYSTEM, it can enter the new mode that was requested in the command.

Facility Code - In the Facility Code mode, authorization decision is based on card only and not the user record. This mode shall use the following credentials to make access grants and denial decisions: Facility Code if present on the card, Authorization Code if present on the card, or Activation and Expiration date, if present on the card.

For Wiegand data, either Facility Code or Authorization Code must be present on the card for validation in this mode. In this mode, after the card is authorized, the user database is searched to see the card is a special purpose card. If the card is authorized, the access shall be granted regardless of whether the user exists in the database or not. LOCK can enter Facility Code mode from any other mode based on Automatic changes, or a command from the SYSTEM via WAP. LOCK can exit Facility Code mode based on Automatic changes, or a Command from the SYSTEM via WAP. The SYSTEM can make sure that when the LOCK is in Facility Code mode it does not get configured to always deny access.

## **4. PROJECT HARDWARE AND SOFTWARE DESIGN DETAILS**

Like research, much of our design was done independently. We did have meetings, emails to address our module specifications and have interactions, but for the most part, time was saved by making the designs on our own time. We agreed to meet twice a week to finalize a document so that the paper would be fluent and any erroneous information would be replaced with relevant topics.

### **4.1 Card Reader Subsystem**

The Card Reader subsystem shall provide the ability to regulate access through doors. Through the research we have decided to use MaxiPro 5375 for card reader, Prox card II and Wiegand converter for reader controller interface. These entire products meet our requirement of our product which is the reader can read the card at least 2 feet range. More discussion about products is follow.

#### **4.1.1 125 kHz Long Range Proximity Card Reader 5375**

The RFID reader we decided to use for our project was the Long Range Proximity Card Reader 5375. Though it seemed many RFID projects had been designed in the past, this specific reader was particularly new. The whole idea is not to have to hold the tag right up next to the door and have the key be hands-

free. The long range Proximity Card Reader 5375 created by HID Corp. It could read a tag up to six feet away depending on local installation conditions and the card tag. This specific reader takes advantage of a polarized antenna, which is connected to the reader. Basically what this means is that the antenna will have an easier time picking up the signal if it is in a direct line from the antenna, but will still pick it up if it is close enough. This allows us to walk up with the tag and have the reader automatically detect it and open the door.



**Figure 4.1.1: MaxiProx 5375 Reader  
(PHOTO BY HID GLOBAL CORPORATION)**

The system that we decided to use is one in which the person will be able to walk past the antenna and the antenna will continuously read the tag until it is out of range. Since the person will be entering through a doorway, an extremely long range is not needed. The reader will also get some help from the PIC. As soon as the tag is in range, the PIC will delay for three seconds. If this setting did not occur, the reader would be continually read and unread the tag and would require much more precision. The reader provides audible and LED flash feedback to indicate access granted/denied decisions. Upon a card in the range, beep and green LED flash will indicate access granted and vice versa for access denied.

RF proximity readers are extremely popular because they can be mounted on an anything surface besides metal; Long Range Proximity Card Reader 5375 readers can read HID cards through brick walls, concrete, plaster, dry wall, glass, plastic, wood and other construction materials. The reader may optionally include card reader back boxes for conduit installations.

The following is an example of an ID card with the number of “816” decimal, which will be output by the MaxiProx reader, the number “02004CA0661” hex (the customer code is never transmitted or displayed)

Customer code 10 zeros (17)	Sentinel bit (1)	Parity even (1)	Facility code (8)	Card number (16)	Parity odd (1)
[0000 0011][0 0000 0000 01][11][01][0 1100 101][0 0000 0110 0110 000][11]					
0   2   0   0		4	C   A	0   6   6   1	
Wiegand Output		0	C   A	0   6   6   1	
Hex code numbers		[ 6   5	][ 0	3   3   0 ]	
Decimals conversion		[ 101	][ 0816	]	

## 4.1.2 ProxCARD II

For the purposed of the project, we plan to use Proximity Card II with read range up to 24” to meet all our specification. The shorter of the reader range, it will reduce the cost of project. The ProxCARD II requires a minimum of 5VDC for operation and will accept up to 16 VDC input. It draws an average of 35 mA at 12VDC and has a peak current draw of 125 mA. Cards has encoded as 26 bit Wiegand to utilizing proximity technology. The card is small as credit size and insensitive to magnetic fields and dirt.



**FIGURE 4.1.2: PROXCARD II  
(PHOTO BY HID GLOBAL CORPORATION)**

## 4.1.3 Reader Converter Interface: OEM Wiegand converter

The Wiegand converter requires a regulated power source of 5 VDC or 8-16VDC, 100mA for internal operation. The RS-232 communications parameters are: 9600 baud, N no parity, 8 data bits, 1 stop bit and no hardware flow control.



## 4.1.4 Power Supplies

Power Supplies for hardware designed specifically for the system equipment installed. The MaxiProx reader requires a linear power supply with a rating of 24 - 28.5 Volts DC at a minimum of 1.5 Amps per reader. A linear power supply aids maximum reader performance.

MaxiProx readers cycle through low, medium, and high power modes. Whenever the MaxiProx switches into high power mode it demands up to one Amp of instantaneous current. Switching supplies monitor the output voltage and adjust by rapidly switching current “on” and “off”. As a result, current supply can lag behind the demand of the load. This also causes fluctuations in the voltage of the power supply, compounding the problem. The result is a reduced read range. In contrast, linear power supplies are always on, ready to supply constant voltage and current. MaxiProx readers surround themselves with a radio frequency excite field. This RF energy field provides power to HID Proximity cards. The field is elliptical in shape and extends about three feet in front of and behind the reader. The field also extends about 8” from the edges of the reader. Metal of any type (aluminum, copper, lead...) should be avoided when mounting a MaxiProx. Even non-ferrous metal within the field can affect reader performance in two ways: metal absorbs the excite energy that is meant to power the card and metal de-tunes the reader’s antennas.

Reduced read range is the result. The degree to which the read range is affected is dependent on how much and how close the metal is to the reader. If metal is unavoidable, then absorption loss will be likely. But the de-tuning effect can be somewhat compensated by re-tuning the reader. Since all RFID (Radio Frequency Identification) readers are radio frequency devices, care should be taken to avoid Radio Frequency Interference (RFI) in the mounting area. Some electronic equipment can generate RFI at a frequency that interferes with the card data transmission to the reader. As an analogy, when a vacuum cleaner is plugged into the same power line as a television, the TV’s reception becomes very poor, but the picture quality returns to normal once the vacuum is turned off. There is nothing wrong with the TV; the vacuum motor generates “noise” (unwanted electrical frequencies) on the power line.

Some computer monitors, vehicle detects loops, and industrial equipment can emit RFI that causes interference with the card data transmission to the reader. Most equipment does not emit an interfering frequency. But it is best to plan the placement of readers away from equipment that generates RFI. MaxiProx readers can also interfere with each other, so they should not be mounted closer than six feet back to back, or three feet side by side. Cross reads can also occur. This will cause the card data to be transmitted by the wrong reader. If ambient RFI is the suspected cause of low read range, try turning the reader 90 degrees (if the reader faces north, then turn it to face west or east). RFI is often directional.

## 4.1.5 Installation

The reader is a self contained proximity reader. The two piece polycarbonate enclosure has a rubber Gasket that seals the pieces together and a cable fitting that seals the cable entry. The water resistant unit is approved for outdoor use. The enclosure is designed to fit on a single gang electrical box. A Bi-color LED and audible tone enhance user feedback. A tamper switch feature is available that will alert the PIC when the enclosure is opened. (not in scope of the project) An internal DIP switch makes the configuration of the outputs; audible tone, keypad and LED control options simple.

Card reader shall install at unsecured side of door. Installation of the reader consists of mounting, verifying the DIP switch settings, setting a tuning jumper and connecting the cable to the reader converter.

## 4.2 Speaker Recognition Subsystem

### 4.2.1 Texas Instruments MSP430 Ultra Low Power Microcontroller

The Texas Instruments MSP430 Ultra Low-Power line of Microcontroller units is programmable MCUs with very cost-effective capabilities integrated into small multiple-pin packages. Each MCU utilizes a 16-bit Reduced Instruction Set (RISC) CPU. Integrated into the MCU are random-access memory (RAM), read-only memory (ROM), Flash memory, and a multiple-mode clock interconnected on common memory address and memory data buses. These features allow the MSP430 MCUs to be utilized in a wide variety of low-voltage, cost-efficient applications ranging from simple liquid-crystal display (LCD) marquee to temperature, humidity, and light sensing applications.

The amount of RAM, ROM, and Flash memory available to each MCU varies between models, ranging from 128 B to 18 kB SRAM and 0.5 to 16 kB combined ROM/Flash memory.

Contributing to the MSP430's ease of use is its 16-bit low-power RISC CPU, with 27 core assembly instructions and 7 addressing modes (register, indexed, symbolic, absolute, indirect register, indirect auto increment, and immediate modes) capable of reaching clock speeds up to 16 MHz (typically reached with 3.3 V reference voltage).

At the CPU's disposal are sixteen 16-bit registers: registers R0 through R3 have reserved functions, such as the stack pointer (SP/R1), program counter (PC/R0), status register (SR/R2[0:7]), and constant generator register (CG1 and

CG2/R2[8:15] and R3); registers R4 through R15 are general-purpose registers and can be used as necessary.

As with typical assembly code, basic arithmetic (addition, subtraction, single and double increment and decrement) as well as logical operations (and, or, exclusive-or, and not-and) are available in addition to branching (jump, call), rotational, status flag-setting, interrupt and reset, and comparing instructions. However, high-level language support is available for all MSP430 devices so knowledge of assembly code is not necessary. The MSP430 series MCUs currently support the C-programming language, so those unfamiliar with assembly code can still utilize the MCU without much difficulty.

What distinguishes the MSP430 series MCUs from TI's competitors, however, is its unique low-voltage requirement. With a bare-minimum operating voltage of 0.9 V, a minimum Flash memory programming voltage of 2.2 V, and a maximum operating voltage of 3.6 V, the MSP430 series MCUs are the lowest-voltage microcontrollers available.

For the purposes of our speaker recognition subsystem, we will be using the MSP430-F449 surface mount MCU.

### 4.2.1.1 **SoftBaugh ES449 MSP430 Evaluation Board**

In order to fully evaluate the capabilities of the MSP430 series MCUs it is strongly recommended that evaluation boards built specifically for the series are used. One such board is the SoftBaugh ES449 evaluation board for the MSP430-F449 MCU.

The ES449 was built specifically for showcasing the strengths of the MSP430-F449 MCU. As such, it has extra functionality that is easily supported by the MCU, such as an RS232 port for serial communications (used mainly in DSP interfacing as outlined in TI Application Report SLLA174 "Interfacing the MSP430 With a DSP Application", ability to use either a single AA, AAA or CR2032 coin cell battery, 4 LED available to software, 2 physical user switches, 32 kHz quartz watch crystal for accurate time-keeping, I/O ports readily available as straight male headers, and access to the MCU built-in low-voltage DAC12 (if using the DAC12, it is important to note that an in-line amplifier is necessary to achieve a readily-available signal for audio playback or otherwise).

A boasted key feature of the ES449 evaluation board is the SoftBaugh SBLCDA2 LCD display mounted directly on the board. With the included driver, programmers will find it easy to display data with a wide range (2.7V to 3.6V) of operating voltages characteristic of the MSP430, seven 14-segment digits with a plus-minus symbol, four additional 7-segment digits (can be used as a clock in

conjunction with the 32 kHz quartz watch crystal; both displays have decimal and colon symbols available to extend usefulness), 3-segment battery display, 3-segment antenna display, 10-segment software-available progress bar, directional arrow display, and up to a 6 o' clock viewing angle with max (3.6V) supply voltage.

A pre-drilled PCB-style prototyping area is available for soldering other additional components onto the board.

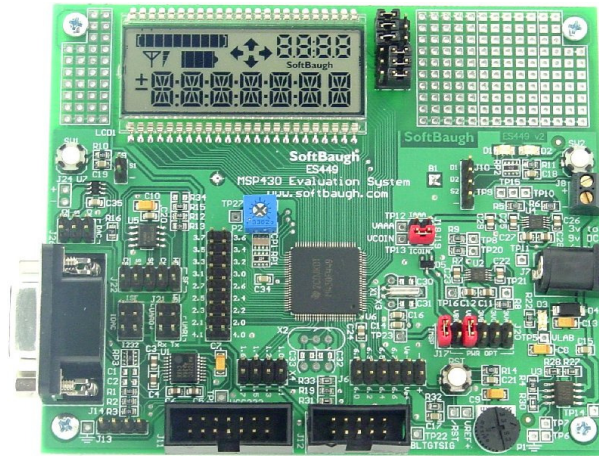

**FIGURE 4.2.1.1: SoftBaugh ES449 MSP430-F449 Evaluation Board with SBLCDA2 Display**

Although TI's line of microcontrollers are efficient for many low-power uses, they are not powerful enough to process large amounts of data, like the voiceprint data, necessary for the completion of our project, quickly or completely enough such that the system performs to a minimum level of necessity. In the case of our project, real-time speaker recognition is necessary, and the MSP430 series is not capable of performing that.

However, the MSP430 series is perfect for displaying raw waveform data in the form of a real-time, two-dimensional LED spectral density display in parallel to another component, a digital signal processor, handling the voiceprint data in real time. The SoftBaugh ES449 evaluation board is available for \$199.00 USD.

## 4.2.2 Texas Instruments Digital Signal Processors

In recent years Texas Instruments has developed a large assortment of digital signal processors (DSP) that can be used in an equally wide variety of end-user applications. With DSPs, ARM microprocessors, or a combination of both integrated onto a single chip, typical DSP maximum processing speeds range from 50 MHz to 1.5 GHz, are capable of floating- or fixed-point operations, and can be priced from \$1.95 to \$200.00. Multiple core DSP packages can operate in up to 10 GHz and range from \$40.00 to \$200.00.

Most DSP packages (with the exception of the Ultra Low Power C5000 DSP series) have support for DDR2/DDR3 external memory modules, USB 2.0, SATA and PCIe data connections, memory caching, RAM and ROM to name a few. Because of its low-power consumption (and, consequently, low power output) the Ultra Low Power C5000 DSP series has been known to work best with LCD displays whereas the other, more powerful DSP/ARM microprocessors can output to full video displays. Furthermore, the C5000 DSP series has built-in simple operating systems (OS)

Suggested hardware solutions include cost-effective portable and high-power stationary medical equipment, voice and fingerprint biometrics, portable audio processing and playback including portable headsets, and telecommunications applications.

### 4.2.2.1 Texas Instruments C5000 Ultra Low-Power Digital Signal Processors

Like TI's MSP430G2 Ultra Low Power series of microcontrollers, TI has developed a series of Ultra Low Power digital signal processors, the C5000 series. Geared towards mobile, low power consuming devices, DSPs in the C5000 series are very inexpensive to purchase (ranging from \$1.95 to \$10 USD) as well as program and evaluate (evaluation boards range from \$49 to \$395 USD, and DSP starter kits [DSK] range from \$395 to \$495 USD).

A common misconception is that low power consuming devices are limited in ability and utility. This is not the case of the C5000 series. One suggested use, provided with a specialized DSK, is fingerprint processing. The C5515 Fingerprint Development Kit is one such DSK. Included with the DSK is a source code for simple fingerprint authentication, giving developers a reference to program their own authentication algorithms or for out-of-box use.

Other suggested uses for the C5000 DSP series include active noise cancellation devices, portable audio docks, digital multimeters, and so on.

For our implementation of a speaker recognition subsystem, we will be using the TMS320 C5510 Ultra Low-Power DSP.

### 4.2.2.2 Texas Instruments TMS320VC5510 DSP Starter Kit (DSK)

The Spectrum Digital TMS320VC5510 DSP Starter Kit (DSK) is a development board used to program the C5510 DSP specifically. With a number of peripherals and additional features included for use at the DSP's disposal, it is nothing less than a powerful tool for utilizing the C5510 DSP to its fullest.

Included are a built-in 24-bit stereo codec (TI AIC23 audio codec) with ADC (as opposed to MSP430 8-, 10-, or 16-bit ADC), audio jacks for microphone, line in, speaker and line out, 256 kB flash programming memory (compared to typical 8 kB for MSP430) and 8 MB SDRAM (compared to 18 kB SRAM max for MSP430), as well as a plug-in adaptor for expansions such as daughtercards in interfacing with other processing units, as explained in the next section.

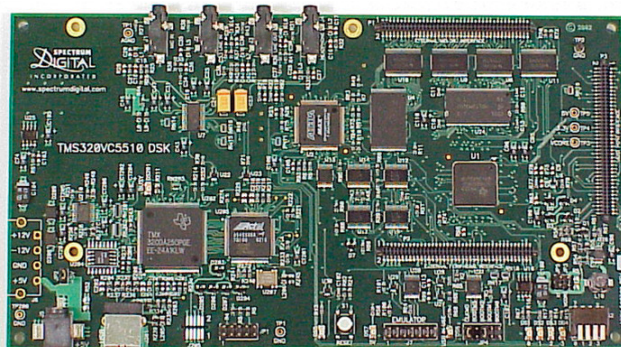

**FIGURE 4.2.2.2: Texas Instruments TMS320VC5510 Digital Signal Processor Starter Kit**

### 4.2.3 Basic Operation

The speaker recognition subsystem will mainly utilize the Spectrum Digital TMS320-VC5510 Digital Signal Processor Starter Kit (DSK). This is because the input/output pins on the TMS320-C5510 DSP are readily accessible as male jumper header pins on the DSK, allowing for simple data transfer to and from the PIC subsystem.

The DSK comes with a 5V input power supply that will be used to power all peripherals on the DSK, as well as provide power for output pins. (The actual output voltage will be determined in software, default 3.3V output)

The C5510 DSP will generally be programmed and debugged using the JTAG (Joint Test Action Group) emulator provided on the DSK. A “netbook” PC will be dedicated to the programming of the C5510 DSP via USB. The netbook PC will also be used to preprogram the user profiles into the C5510 DSP’s flash memory for demonstration and testing purposes. Additionally, the user profiles will be saved on the netbook PC in case of DSP failure. The program flashed onto the C5510 DSP will also be saved on the netbook PC in case of DSP failure.

(Currently the planned method of registering user identities is preprogramming. A learning process can be implemented at a later time but is not important as of this moment. This is purely to demonstrate that the speaker recognition subsystem will only allow the intended individuals to pass the system.)

There will be 4 total input and output pins for data transfer to and from the PIC subsystem. Three (3) pins will be assigned to input from the PIC subsystem and one (1) pin will be assigned to output to the PIC subsystem. The input and output pins will be chosen arbitrarily. They will be connected via jumper wires to the PIC subsystem. Internally, the three input pins will be named I0, I1, and I2; the output pin will be named O.

The speaker recognition algorithm itself will be a simplified Hidden Markov Model (HMM) implementation. See the section “Introduction to Hidden Markov Models (HMM)” for a brief introduction and examples of HMMs.

The basic operation of the system will be as follows:

- I. The speaker recognition subsystem will receive from the PIC a “User ID” in the form of 3 binary digits (bits) to inputs I0, I1, and I2 (the three input header pins) on the DSK. The ID will take the form of (I2, I1, I0). For example, the registered identification of I0 = 1, I1 = 0, I2 = 1 will be represented as “101” (decimal 5) to the speaker recognition subsystem.
  - a) A registered user ID of “000” (decimal 0) will be recognized by the speaker recognition subsystem as “Standby Mode”. It will not be accepting input from the microphone at any time as long as all inputs from the PIC subsystem are zero. The system will not use any extra power for processing, amplifying or filtering microphone input. It will only wait for an incoming user ID.
  - b) The registered user IDs can range from 001 (decimal 1) to 111 (decimal 7). As such, there can be a maximum of seven registered users in the system at any time.

- II. The speaker recognition subsystem will then accept input from the microphone. The user will say his/her passphrase into the microphone once within range of the RFID reader.
  - a) A LED will illuminate to indicate that the speaker recognition subsystem is awaiting voice input from the user. While the system is in “Standby Mode” the LED will be off.
- III. Once the system has recorded the user’s voice sample, it will process the recording.
  - a) An embedded analog-to-digital converter (ADC via TI’s AIC23 audio codec) will convert the analog microphone input into a 16-bit digital signal of signal amplitudes. The recording frequency can be set to the common frequencies of 48 KHz, 44.1 KHz, or 8 KHz.
  - b) The DSP will send frequency and amplitude data in real-time to the MSP430 to display on the two-dimensional array LED power spectrum.
  - c) The system will remove silences at the beginning and end of the passphrase to ensure the identity of the passphrase best matches the claimed identity of the user obtained from the registered user database.
  - d) The recording will be split into equal sections of 100 ms.
  - e) For each section, calculate the mel frequency cepstral coefficients.
  - f) Each section’s coefficients will be compared to the known coefficients obtained from a database.
  - g) If a majority of the sections are considered “matches”, then the claimed identity of the user matches the user’s voice print identity.
- IV. If the system detects a match between the claimed identity and the real identity of the speaker, it will output a “1” on the output pin “O”. If the system detects that the claimed identity and the real identity of the user do not match, it will output a “0” (zero) on the output pin.
  - a) While the system is processing the voice data, it will output a “0” (zero) on the output pin. Likewise, until the system detects a match between the user’s claimed and real identity, it will output a “0” (zero) on the output pin.

The basic operation of the system is best summarized by the following flowchart.

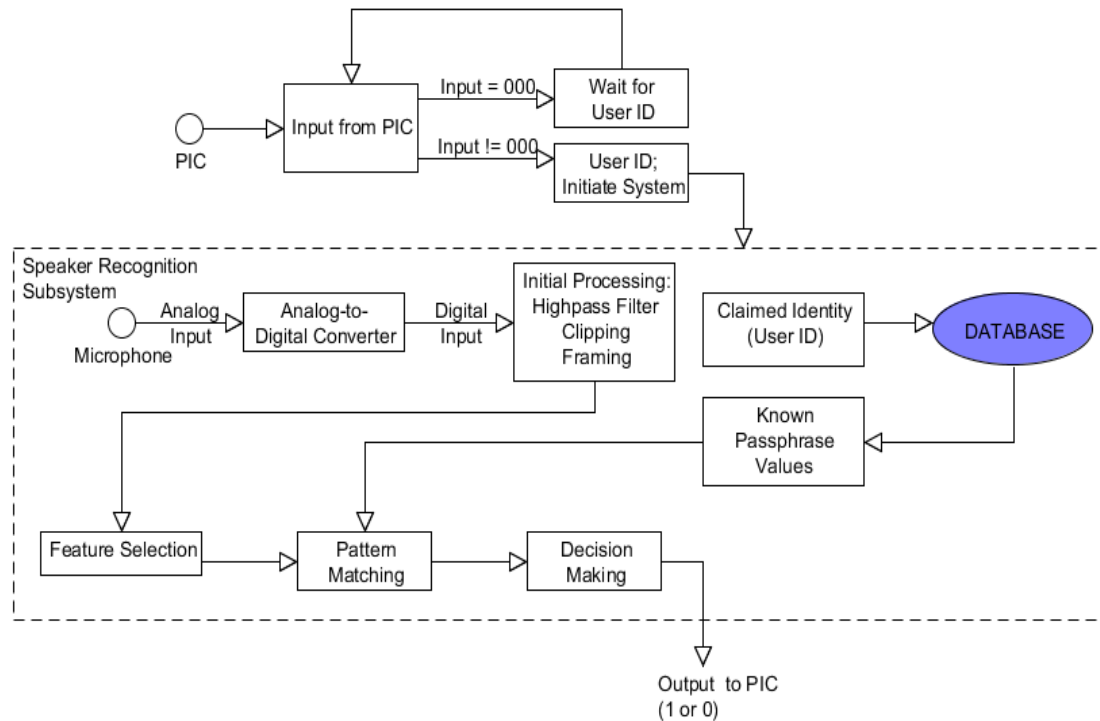
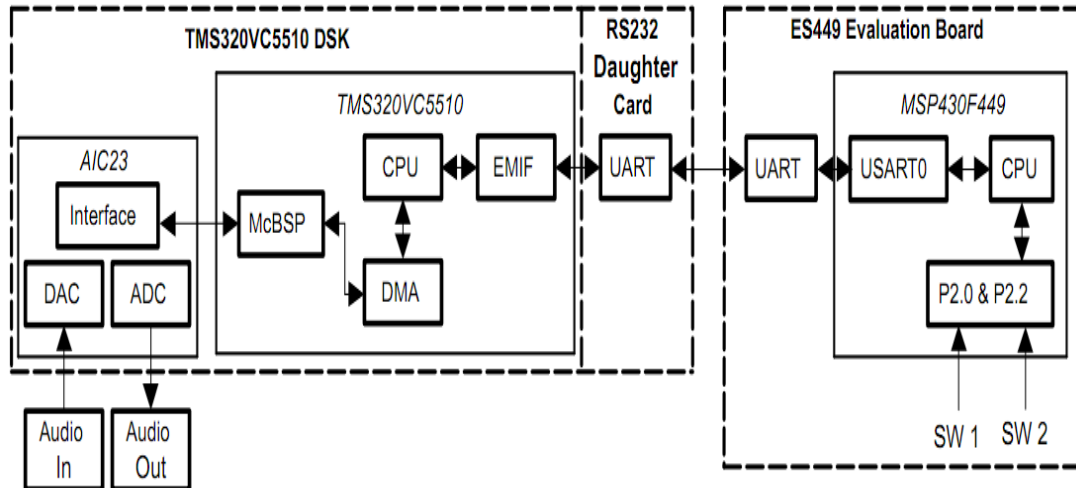

**FIGURE 4.2.3: Basic operation of speaker recognition subsystem given User ID from PIC subsystem**

### 4.2.3.1 Interfacing MSP430-F449 Microcontroller with DSP320-C5510 Digital Signal Processor

The C5000 DSP and MSP430 MCU will be interfaced through the DSPGlobal IS-232 UART RS232/422 Daughtercard via serial cable connection as outlined in TI Application Report SLLA174 “Interfacing the MSP430 With a DSP Application”.

The daughtercard connects directly to the DSP without any connecting cables. A standard straight-through DB9 serial cable will connect the daughtercard to the MSP430 via the evaluation board RS-232 interface. The following diagram from the Application Report SLLA174 summarizes the interface between the C5000 DSP (TMS320VC5510 DSK) and the MCU (ES449 MSP430F449) through the daughtercard.

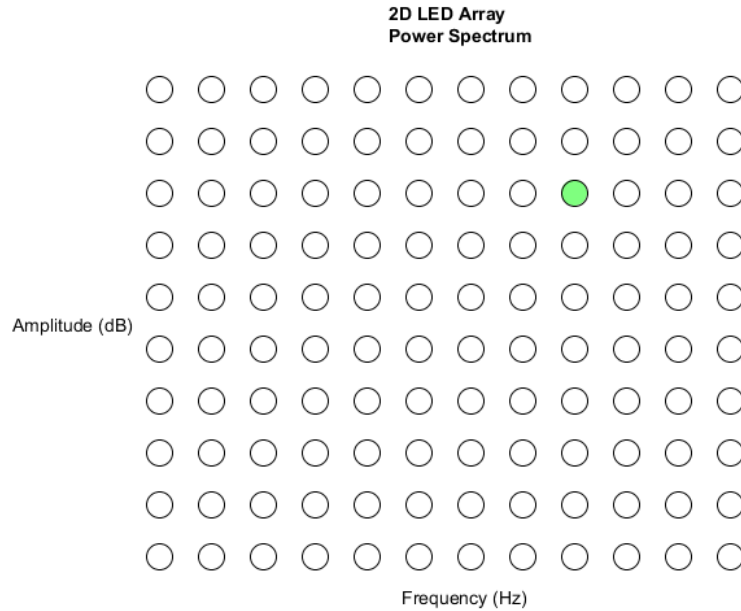

**FIGURE 4.2.3.1:1: Diagram of interface between SoftBaugh ES449 MSP430-F449 Evaluation Board and Texas Instruments TMS320VC5510 Digital Signal Processor Starter Kit through DSPGlobal IS-232 UART RS232/422 Daughtercard**

In the provided implementation of interfacing the MSP430 MCU with the C5000 DSP, the DSP was used for converting an analog audio signal to a digital signal through ADC, then converting back to an analog audio signal through DAC, whereas the sole function of the MSP430F449 was to control the volume at which the audio was played back.

We've already shown our application of the TMS320VC5510 DSK, which contrasts to the application provided in SLLA174. Likewise, our application of the MSP430F449 extends beyond controlling a single option on the DSK. This application, briefly mentioned in the basic operation section earlier in this document, will be further explained now.

The DSP will provide the frequency and amplitude of the incoming speech input to the MSP430F449. With a set of mux units a two-dimensional array LED representation of the spectral density will be displayed by the MCU. Alternatively, separate gauges for the frequency and amplitude of the incoming speech sample can be set up side-by-side to display the respective values.



**FIGURE 4.2.3.1.2: Two-dimensional LED Array of Frequency-varying Power Spectrum**

This is the proposed two-dimensional array LED representation of the power spectrum. Each circle represents a LED; the green-filled circle is a singly-lit LED. Each column of LEDs represents a range of frequencies – if the frequency is between  $f_{x1}$  and  $f_{x2}$ , a LED will be lit on column  $m$ . Likewise, each row of LEDs represents a range of decibels – if the amplitude is between  $a_{y1}$  and  $a_{y2}$ , a LED will be lit on row  $n$ . The intersection of column  $m$  and row  $n$  is the lit LED.

## 4.2.4 Comparison to Images SI Speech Recognition Kit

There are notable differences between our system and the SI Speech Recognition Kit SR-06/7. The central component of the SR-06/07 is the HM2007 speech recognition processor chip.

Advantages of our system – While less expensive to implement than a C5000 DSP, the HM2007 is hard-coded to only accept a maximum of 1.92 seconds worth of individual passphrase length for a total of 20 passphrases, or .96 seconds worth of individual passphrase length for a total of 40 passphrases, whereas our system can handle a substantially larger word length and quantity. It also requires a 5V supply voltage as opposed to typical 3V supply voltage needed by the C5000 ultra-low power DSP. Estimated response time of the HM2007 is 300 ms, while the response time of our proposed system is yet to be determined (but expected to be shorter).

Advantages of HM2007 – The HM2007 also has automatic learning capabilities, while our system is at this moment slated to be capable of a preprogrammed learning phase. Unlike our system the HM2007 can be standalone (manual) or coupled with an external computer (CPU).

Currently, the methods of feature selection and pattern matching of the HM2007 aren't available to us. However, because it is relatively inexpensive and boasts simple operation it most likely implements an unprocessed power spectrum with vector quantization. We will be using mel frequency cepstral coefficients (which require more processing than just a power spectrum) and a hidden Markov model for pattern matching.

## **4.2.5 Profile Enrollment and Management with Dedicated Netbook**

We will have at our disposal an inexpensive, dedicated netbook for the sole purpose of programming the DSP and MCU to meet the speaker recognition needs as well as profile (voiceprint) management. By using only the dedicated netbook for our project, we can avoid the installation and startup of many unnecessary programs that would otherwise hinder efficient programming or management on our personal systems (in the spirit of keeping separate our “work” and “play”). In addition, netbooks offer a mobility absent from other options of programming the system in a non-stationary setting (movable demonstration display) – large laptop PCs are not preferable as they can reach sizes in excess of 17 inches, which is too large to continually transport with the already-bulky door hardware as well as keep a low-profile when accessing the system in smaller spaces.

Netbooks of this day and age have superiorly fast boot times, so in the event emergency programming of the speaker recognition system is necessary the netbook can reprogram the system in a timely manner (beginning with system boot). High cost-efficiency is also achieved as many netbooks come as low as \$200 USD, much less than the evaluation boards they will be used to program.

Currently there is no automated learning process planned for our senior design project, as we are only performing a demonstration of the most basic specifications outlined in the Introduction. As such, the only “learning process” is preprogramming the profile of each intended speaker into the DSP using the selected feature selection and pattern matching methods as guidelines.

Having no automated, “built-in” learning process is definitely a disadvantage of our system currently, but in the same respect profiles can be managed and added off-site and programmed into the system at a later date and time.

Programming will be achieved using TI's Code Composer Studio, free as an evaluation version on TI's web site [www.ti.com/tool/ccstudio](http://www.ti.com/tool/ccstudio) or included as a

fully-functional version with the Spectrum Digital TMS320 VC5510 DSK. Code Composer Studio can fully program the MSP430 (up to 16 kB with evaluation, no limit with the full version) series MCUs as well as the C5000 series DSPs.

## 4.3 Electric Door Latch Subsystem

The Electric Door Strike Subsystem shall provide the ability to open the door without having to insert a key and turn a knob utilizing industry standard hardware utilizing proven technologies. The manufacturer of our components has been chosen for his cost effective yet robust offerings. The product line proposed meets our requirements appropriately. More discussion about products to follow.

### 4.3.1 Electric Strike

The Electric Strike we decided to use for our project was a fail secure stainless steel constructed 12 volt steel/wood frame suitable dc device. Though it seemed many latch assemblies existed with wide ranging pricing schedules, this was determined to best fit the residential through commercial application that we sought. This readily available, yet robust industry tested latch set insures long life and ease of installation for both new construction and upgrade retrofit.



**FIGURE 4.3.1 ELECTRIC STRIKE**

Initially, both an electric strike and a magnetic lock were considered. Both security and safety concerns were not met with confidence utilizing the magnetic variety. Magnetic locks require either fail safe (loss of field upon loss of power) giving rise to security concerns and pin type fail secure (pin retained in door upon loss of power) gave safety concerns. Also, AC versus DC decisions needed to be made. First, DC electric strikes last longer, are quiet and have more options available. Second, the DC variety was less expensive and more readily available. In addition to the safety and security concerns were that of initial and installed cost of devices. The magnetic locksets that would be suited for the project were considerably more expensive, were less immediately available and would require both more initial labor to install and would carry a certain maintenance concern

as their alignment is more apt to be a concern. For example the highest rated magnetic lock was rated at 1200 lb pull force – and with that came a considerable price; whereas, the typical pull force rating on an electric strike is 1200 lb. force. Finally, given that we wanted both a controller board and the ability to provide a DC back-up source locally to the strike as a possible option at a later date the DC electric strike seemed an obvious choice.

### 4.3.2 120V to 12V Transformer

A wall mounted step down transformer of the 500 VA rating was determined to be best suited for our application. This size will insure future addition of options to include status buzzer and perhaps lights. This particular design is readily plugged into the wall not requiring a dedicated circuit.



**FIGURE 4.3.2.: TRANSFORMER**

### 4.3.3 Strike Timer Module

Sized to coordinate with our electric strike, this outstanding controller works seamlessly for a wide range of applications allowing timing for various users with their many needs. Additionally, the on board rectifier simplifies circuit design and provides its voltage source in close proximity to the latch assembly reducing voltage drop.



**FIGURE 4.3.2: TIMER MODULE**

### 4.3.4 Magnetic Contact/ prox switch

This almost invisible sensing device chosen is both aesthetically pleasing and robust in its design. Giving a long life with trouble free operation, this magnetic device minimizes interaction between user and system while providing immediate door status.



**FIGURE: 4.3.4: MAGNETIC CONTACT**

### 4.3.5 Push to Exit Switch

Although the user has the option of exiting utilizing typical exit hardware, this push to exit switch enhances the operation of the system by allowing minimal contact. An additional benefit is the ability to provide exit for times when one is disabled from actuating typical door hardware – again, providing an almost hands free exit.



**FIGURE 4.3.5: DOOR EXIT**

### **4.3.6 Time Module to PIC Integration**

Designed to meet the needs of the processor, this optional integrator board will be sized to meet applicable demands in the event the contacts provided by the PIC are not suitable

### **4.3.7 Demonstration Door Frame Assembly**

A pre-constructed door frame assembly was chosen yet utilizing the most economical and durable building materials available. This attractive door assembly should showcase the door subsystem handsomely.

## **4.4 PIC Subsystem**

The system utilizes a single seamlessly integrated relational database for all functionality. This integration will be provided with one operating environment. The system's operating environment will be the fully multi-tasking multi-threading

The PIC subsystem is responsible for tying together all of the other independently functioning subsystems and providing the desired functionality to the project as a whole. This is accomplished through a combination of hardware and software design. The hardware design involves designing a printed circuit board that includes all of the electrical connections that are necessary to facilitate communication between the various subsystems. The software design involves coding the microcontroller to provide the precise sequence of operations that are outlined in this document. Both the hardware and the software will be designed congruently in order to avoid design errors due to incompatibility. The specific hardware and software design details, as they relate to the PIC subsystem, are provided below.

### **4.4.1 Microchip PIC16F877A**

The Microchip PIC16F877A microcontroller is the centerpiece of the PIC subsystem and really the project as a whole. Without the microcontroller, none of the other subsystems would function as they are supposed to function. In terms of hardware, the PIC16F877A shares an electric connection with virtually every other aspect of the project. Many of these components operate at higher voltages than the microcontroller and carry larger currents; careful consideration had to be given in designing these connections. The PIC16F877A operates at frequencies up to twenty megahertz, voltages in the range of 4.0 V to 5.5 V, and currents as high as two hundred and fifty milliamps. The specific connections for each subsystem are provided in detail later in this section; however, there are certain

connections that are internal to PIC subsystem. Descriptions of those connections are provided below.

#### 4.4.1.1 Description of Connection to Power Supply

The microcontroller will connect to the five-volt power supply through a four terminal block that will be mounted on the surface of the printed circuit board. The power supply has two wires that will connect to the block: power and ground. The power wire will connect to the microcontroller's  $V_{DD}$  pins via the printed circuit board and provide power to the microcontroller. The ground wire will connect to the microcontroller's  $V_{SS}$  pins to ground the circuit board. The remaining two terminals are used to provide power and ground to the speaker recognition subsystem. These connections are necessary because the PIC subsystem and the speaker recognition subsystem share the same power supply, but the power supply only provides the two wires, not four. These connections will be kept separate from the main circuit. The incoming power signal will be split at the terminal. One trace will connect to the main circuit, while the other trace will connect to the outgoing power terminal for the speaker recognition subsystem. The incoming ground signal will be split in a similar manner with one trace connecting to the main circuit and the other trace connecting to the outgoing ground terminal for the speaker recognition subsystem.

#### 4.4.1.2 Description of Connection to Programmer

The microcontroller's connection to the programmer is the only connection to a peripheral device that will not utilize a terminal block. Instead of a terminal block, six 0.025" square pins with 0.100" spacing will be used to connect to the programmer. The six pins that make up this connection are designated as  $V_{PP}/MCLR$ ,  $V_{DD}$  Target,  $V_{SS}$  (ground), PGD, PGC, and auxiliary. The  $V_{PP}/MCLR$  pin provides voltage for programming and master clear functionality. The pin will connect to the  $V_{PP}/MCLR$  pin on the microcontroller through the reset pushbutton that will be mounted on the surface of the printed circuit board. The  $V_{DD}$  pin and the  $V_{SS}$  pin will be connected to their respective pins on the microcontroller. The PGD pin will connect to port B at pin seven, while the PGC pin will connect to port B at pin six. These pins on the microcontroller provide special functionality for in-circuit programming. The auxiliary pin will have no connection to the circuit; however, it will still be included since there is a specified port for it on the programmer.

The programmer will connect to the printed circuit board by plugging the programming connector into the square pin connectors mounted on the board. A USB cable will be used to connect the programmer to a computer. A hex file is used to program the microcontroller. The hex file will be generated from C code by the Small Device C Compiler. The programmer includes software that will be used to burn the generated hex file into the microcontroller's memory. Once the microcontroller is successfully programmed, the file will remain in the microcontroller's memory until the reset button is pushed, which will clear the microcontroller's memory. The programmer can be disconnected from the printed circuit board once programming has been verified and it is confirmed that the device has been successfully programmed. However, the programmer will have to be reattached to reprogram the device if the reset pushbutton is accidentally pressed.

## **4.4.2 Integration with Card Reader Subsystem**

### **4.4.2.1 Description of Connections**

The microcontroller will connect to the card reader subsystem via a simplified RS-232 protocol connection that does not require a physical RS-232 connector. The standard RS-232 connection utilizes nine pins, but the connection between these two subsystems will only require three pins. The three pins that will be used from the RS-232 protocol are receive data, transmit data, and ground. The receive data pin on the microcontroller side will connect to the transfer data pin on the card reader side. Conversely, the transmit data pin on the microcontroller side will connect to the receive data pin on the card reader side. The ground connection is necessary to provide a common ground between both the five-volt power supply and the twelve-volt power supply. There will also be two additional connections between the microcontroller and the card reader subsystem. There will be one connection to the red LED and another connection to the green LED. This makes for a total of five connections between the microcontroller and the card reader subsystem. These connections will span two ports, port D and port E. The decision to use two ports was made because control of the LEDs does not necessarily correspond to transmission of data. Port E will be used to operate the red and green LEDs. Port D will handle data transmission to and from the card reader subsystem.

### **4.4.2.2 Sequence of Operations**

Whenever the system is idle, the red LED on the card reader will be lit. This indicates that there is no RFID card in range of the system. The code will loop

infinitely until a card comes in range. When a card does come in range of the receiver, the card reader will transmit the necessary identifying information that corresponds with that card to the microcontroller. There will be a brief delay as the microcontroller receives this data. Once the card has been identified, the microcontroller will extinguish the red LED, turn on the green LED, and proceed to communicating with the speaker recognition subsystem. The green LED will remain lit until one of two conditions is met. The first condition involves the card moving out of range of the reader. When the card moves out of range of the reader, the microcontroller will cease communication with the speaker recognition subsystem, extinguish the green LED, and light up the red LED again. The second condition involves a positive voice match and subsequent unlocking of the door. The green LED will remain lit until the microcontroller receives a signal from the electric door latch subsystem indicating that the door has once again been locked. When this signal is received, the green LED will be extinguished, the red LED will be lit, and the system will remain idle until another card comes in range of the card reader, which will repeat the sequence from the beginning.

### **4.4.3 Integration with Electric Door Latch Subsystem**

Should the contacts provided by the PIC not be suitable for the application, a board shall be provided that allows for this larger current draw. This additional component shall be designed to meet the load applied by the electric door latch subsystem.

#### **4.4.3.1 Description of Connections**

The microcontroller will communicate with the electric door latch subsystem in a number of ways. First, the microcontroller will share a two-pin connection with the door status switch of the electric door latch subsystem. One pin will be designated for output, and the other pin will handle input from the switch. These connections will allow the microcontroller to keep track of whether the door is locked or unlocked at any given time. These connections are necessary because locking the door after entry is handled internally by the electric door latch subsystem rather than directly by the microcontroller. The microcontroller shares an additional one-pin connection with the electric door latch subsystem that handles unlocking the door. When activated, this connection will effectively close the circuit of the electric door latch subsystem allowing it to unlock the door for a specified amount of time. The final connection between the microcontroller and the electric door latch subsystem is a ground wire to provide a common ground between the five-volt power supply of the microcontroller and the twelve-volt power supply of the electric door latch subsystem. These connections will be made with the microcontroller through a four terminal block with three of the

terminals tying into port A on the microcontroller and the remaining terminal connecting to ground on the printed circuit board. The push to exit button shares no direct connection with the microcontroller. The microcontroller will only know that the button has been pressed through its connection with the door status switch.

### **4.4.3.2 Sequence of Operations**

Whenever the system is idle, the output connections for the door status switch and the operation of the locking mechanism will be set to a value of zero. When a valid card comes in range of the receiver and the voice of the user is positively matched against the profile voice, the microcontroller will send a signal to the switch to change the status of the door to unlock. The door status switch will process the request and send a signal back to the microcontroller indicating that the status of the door has been changed to unlocked. Once this status change has occurred, the microcontroller will send a signal to the electric door latch subsystem that allows it to unlock the door. The door will remain unlocked for a specified amount of time, after which the door status switch will revert to the locked status. When this change occurs, the door status switch will send a signal to the microcontroller indicating that the door has once again been locked. When this signal is received by the microcontroller, the output connections for the door status switch and the operation of the locking mechanism will be reset to a value of zero. All outputs to the speaker recognition subsystem will be reset to zero, the green LED of the card reader subsystem will be extinguished, and the red LED will be lit up. This sequence of events indicates that the system is once again idle and will wait for the next valid card to come in range of the receiver to begin the sequence again.

## **4.4.4 Integration with Speaker Recognition Subsystem**

### **4.4.4.1 Description of Connections**

The microcontroller will share a four-pin connection with the speaker recognition subsystem. Three pins will be reserved for output to the speaker recognition subsystem, while the remaining pin will be maintained for input from the speaker recognition subsystem. The speaker recognition subsystem will support up to seven unique voice profiles. The output pins will be used to communicate which of the seven voice profiles is trying to be matched depending on which card is in range of the reader. The voice profiles will correspond to three-bit binary outputs '001' through '111.' An output of '000' will indicate that no match is trying to be made because there is not a valid card in range of the receiver. The input pin will

indicate the result of the attempted voice match. If the presented voice does not match the stored voice in the profile, a value of zero will be sent to the microcontroller indicating a mismatch. If a positive match is made between the presented voice and the stored voice, a value of one will be sent to the microcontroller indicating a match. All of these connections will be made with the microcontroller through a four terminal block that will be tied to port C. There is no need for an additional ground connection between the microcontroller and the speaker recognition subsystem because they already share the same power supply.

### 4.4.4.2 Sequence of Operation

Whenever the system is idle, the three output pins will be designated as '000.' When a valid card comes into range of the receiver, the microcontroller will proceed through a list of conditional statements to check the card's identifying information. When the card is correctly identified, the values of the output pins will change to the specific three-bit binary code that corresponds to the voice profile for the card that is in range. The system will then wait for the results of the voice match from the speaker recognition subsystem. The system will continue to wait until the voice is positively identified or the card moves out of range of the receiver. If the card moves out of range of the receiver before the voice can be positively identified, the three output pins will be reset to '000,' and the system will remain idle until a valid card comes in range of the receiver. Otherwise, the microcontroller will proceed to communicating with the electric door latch subsystem as soon as a positive voice match is made. The speaker recognition subsystem also contains a sequence of LEDs that will function similarly to the LEDs of the card reader subsystem; however, these LEDs are controlled internally by the speaker recognition subsystem and require no interaction with the primary microcontroller.

### 4.4.4.3 Additional Plans

If time permits, there are plans to implement a limit on the amount of time for positive voice identifications to be made. If a positive match is not made in the required time, the card itself will become deactivated for a short period of time. When a card is deactivated, the system will not recognize it as a valid card to gain entry through the doorway. This will act as an additional security measure in case a card is stolen from the rightful owner.

### 4.4.5 PCB Design

Figure 4.4.5 provides a detailed view of the schematic diagram that the printed circuit board will be built from. It shows how and where each of the subsystems

will connect to the microcontroller. It also displays the necessary connections between the programmer and the microcontroller. Additionally, the connection to the external five-volt power supply and the connections that allow the power supply to be shared with the speaker recognition subsystem are expressed as well. The diagram does not display details for the pin connections on the microcontroller though. It only shows the pin numbers where the connection is made. A summary of the connections is provided below with functional details of the microcontroller's pins. This summary should supplement the information that the diagram is missing.

The card reader subsystem connects to the microcontroller at four different pins with the fifth wire connecting to the circuit's common ground. The red LED of the card reader subsystem connects to the eighth pin of the microcontroller, which is pin zero of port E. The green LED of the card reader subsystem connects to the ninth pin of the microcontroller, which is pin one of port E. These are the only two connections to port E of the microcontroller. Port E is dedicated to controlling the LEDs of the card reader subsystem. The transmit data wire of the card reader subsystem connects to the nineteenth pin of the microcontroller, which is pin zero of port D. The receive data wire of the card reader subsystem connects to the twentieth pin of the microcontroller, which is pin one of port D. These are the only two connections to port D of the microcontroller. Port D is dedicated to handling transmission of the identifying information of the card in range of the card reader's receiver.

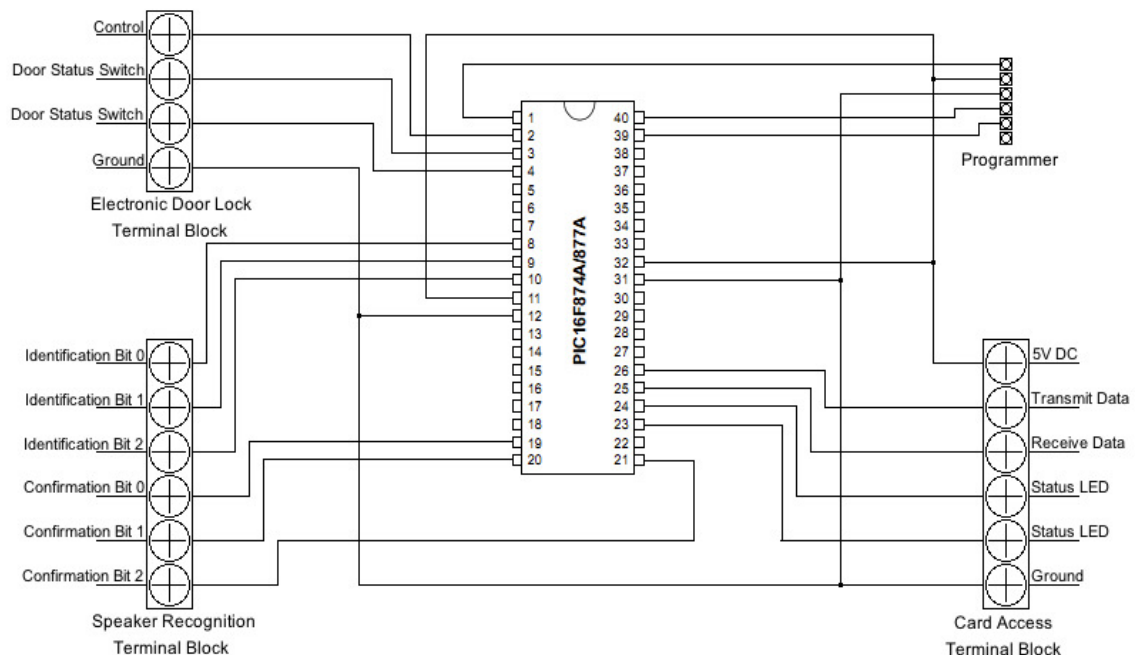

**FIGURE 4.4.5: PIC SCHEMATIC DIAGRAM**

The speaker recognition subsystem connects to the microcontroller at four different pins. Three of these pins are output pins, while the remaining pin is designated as input. The three output pins carry the unique three-bit identification code that corresponds to the voice profile for the card in range of the card reader's receiver. The input pin indicates to the microcontroller whether or not the presented voice matches the stored voice in the voice profile. The second bit of the identification code connects to the twenty-sixth pin of the microcontroller, which is the seventh pin of port C. The first bit of the identification code connects to the twenty-fifth pin of the microcontroller, which is the sixth pin of port C. The zero bit of the identification code connects to the twenty-fourth pin of the microcontroller, which is the fifth pin of port C. The wire carrying the result of the attempted voice match of the speaker recognition subsystem connects to the twenty-third pin of the microcontroller, which is the fourth pin of port C. Port C is dedicated to handling communication with the speaker recognition subsystem. Pins four through seven of port C were used for these connections instead of pins zero through three to reduce the lengths of the traces and improve the efficiency of the design.

The electric door latch subsystem connects to the microcontroller at three different pins with the fourth wire connecting to the circuit's common ground. Two of these pins are output pins, while the remaining pin is designated as input. The two output pins handle communicating with the electric door latch subsystem to tell it to unlock the door. One of the output pins connects to the door status switch to tell it to change the status of the lock, while the other pin is responsible for activating the electric door latch subsystem. The input pin carries a signal from the door status switch that indicates to the microcontroller that the door has been locked again, and the system can begin waiting for the next entry request. The input signal from the door status switch connects to the second pin of the microcontroller, which is pin zero of port A. The output signal to the door status switch connects to the third pin of the microcontroller, which is pin one of port A. The control signal for the electric door latch subsystem connects to the fourth pin of the microcontroller, which is pin two of port A. Port A is dedicated to operating the electric door latch subsystem and keeping track of the current status of the door.

The programmer connects to the microcontroller directly at three different pins with a fourth connection being made indirectly through the circuit's power lines and a fifth connection being made indirectly through the circuit's common ground. The first pin of the programming connector connects to the first pin of the microcontroller, which is the  $V_{PP}/MCLR$  pin. This connection is necessary for providing voltage for programming and clearing the microcontroller's memory. The connection is made through the reset pushbutton. Normally, this connection provides the necessary voltage for programming the device; however, when the button is pushed, the signal is disrupted and the microcontroller's memory is cleared. The second pin of the programming connector connects to the circuit's power lines. The third pin of the programming connector connects to the circuit's common ground. The fourth pin of the programming connector connects to the

fortieth pin of the microcontroller, which is usually pin seven of port B, but also provides the special PGD function for programming. The fifth pin of the programming connector connects to the thirty-ninth pin of the microcontroller, which is usually pin six of port B, but also provides the special PGC function for programming. The sixth pin of the programming connector is identified as auxiliary, but it does not provide any function in this design. The pin is left with no connection.

The external power supply connects to the microcontroller at four pins, but also shares several other connections in the circuit. The external power supply provides two wires coming into the circuit: power and ground. Both of these wires are immediately looped out of the circuit at the same terminal block to provide power for the speaker recognition subsystem. The power wire connects to the eleventh and thirty-second pins of the microcontroller, which are the  $V_{DD}$  pins. The power wire also connects to the second pin of the programming connector as detailed above. The ground wire connects to the twelfth and thirty-first pins of the microcontroller, which are the  $V_{SS}$  pins. The ground wire also connects to the card reader subsystem, the electric door latch subsystem, and the third pin of the programming connector as detailed above. Through the combination of these connections, it is ensured that the total system circuits all share a common ground.

## 4.5 Sequence of Operation

On the secure side of the door, red LED is normal status of reader and voice panel. Person approaches to RFDI range with the valid RFID card, the LCD green's reader will flash and beep once (reader control not from PIC) to indicate that PIC has acknowledge first identification, then green LCD on voice panel will turn on, indicated that system need the second identification which is the voice data. Person is going to speak his/her password. Once both data have matched with memory data, then PIC will release the door contact. The solenoid release with the click sound, door is unlocked and both LCD turn red, ready for next identification.

If the voice profile doesn't match the system, PIC will command LEDs on reader and voice panel turn red which is normal condition, no action to the door. The RFID card wills timeout in about 5-7 second if there is no action which is repeated wrong voice profile. The system is waiting for the next card in range.

If the reader did not recognize the valid card in the first place then nothing happen, no action follow up for voice active either. Reader works as the filter to activate the voice system.

After the person get in to unsecure side, the door will be close and lock by hearing a solenoid' click. On this side, we have designed a request to exit push

button. Once the button press, door will unlock, following a click sounding from the solenoid.

For any others complicate operation, it can happen but it should be consideration for the future design.

## **5. DESIGN SUMMARY OF HARDWARE AND SOFTWARE**

### **5.1 Hardware Summary**

All the hardware will be furnished to complete the project and shall meet all requirements of specifications and all other codes as applicable. Items of hardware specified in the document have been selected for the purpose of establishing a quality and design standard acceptable to the school project level. Products of other manufacturers of security hardware only may be substituted in later of the project.

Security equipment items specified in the security hardware sets have been selected from the catalogs of HID Global Corporation as the basis of design for the card access control.

The design of the security hands free entry system include devices and equipment to control access of cardholders and assets to restricted area (door), detect and deny unauthorized attempted entry. The security hands free entry system is to be designed and configured to provide operational flexibility, reliable performance, and ease of use.

### **5.2 Software Summary**

The software for the PIC subsystem consists of the code that is used to provide the system with the desired functionality by utilizing the specified hardware connections. The code will be designed to follow the sequence of operations and the state diagram provided earlier in this document. It will be written in C and compiled using the Small Device C Compiler. When the code is compiled, a hex file will be generated. This hex file will be used to program the microcontroller. It will be burned into the microcontroller's memory using the PICkit 2 Programmer. A brief overview of the code design and functionality is provided below to summarize the wealth of information that is available in the previous sections of this report.

When the system starts, the red LED will be lit up. The microcontroller will execute an infinite loop that checks to see if a card is in range of the receiver. When a card comes in range of the card reader, the identification code will be transferred from the card reader to the microcontroller. The microcontroller will then compare this identifying information against a list of valid cards contained in memory. If the card is not found, the system will behave as if there is not a card in range of the receiver and continue waiting for the next valid card. If the card is found, the microcontroller will then convert the card identification information into a unique three-bit binary code that corresponds to the voice profile for that card in the speaker recognition subsystem. The microcontroller will then transmit this three-bit code to the speaker recognition subsystem and wait the results of the voice match. If the presented voice does not match the stored voice in the profile, the system will continue to wait until a positive match can be made. When a positive match is made, the microcontroller will send a signal to the door status switch of the electric door latch subsystem to tell it to change the status of the door. Simultaneously, the microcontroller will send a control signal to the electric door latch subsystem that will activate the subsystem and allow it to unlock the door. The door will remain unlocked for a period of time or until the door is opened and subsequently closed. The microcontroller will keep track of the status of the door through its communication with the door status switch of the electric door latch subsystem. When the timer expires, the system will enter the "Door Locked" state, but it will not proceed to processing the next request for entry until it is confirmed that the door is closed. There would be no need for the system to continue reading cards to unlock the door when the door is already opened. When it is confirmed by the door status switch of the electric door latch subsystem that the door is indeed closed, the system can proceed with addressing any additional requests for entrance from both valid cards and invalid cards.

## 6. PROJECT PROTOTYPE CONSTRUCTION AND CODING

### 6.1 Card Reader Subsystem

#### 6.1.1 Reader Function

The table 6.1.1 is shown how the LED of card reader functions during operation.

CARD READER LED-BEEPER FUNCTION			
Card Present	Beeper	Green LED	Red LED
No card	None	Off	On
Valid Card	Once beep	Flash	Off
Invalid card	None	Off	On

**TABLE 6.1.1: CARD READER FUNCTION**

#### 6.1.2 RS232 Communications

The card reader is communicating with the PIC microcontroller via RS-232 EIA standard protocol. The RS-232 standard defines the voltage levels that correspond to '1' and '0' levels for the data transmission and the control signal lines. Valid signals are plus or minus 3 to 15 volts; the  $\pm 3$  V range near zero volts is not a valid RS-232 level. The serial port transmits a '1' as  $-3$  to  $-12$  volts and a '0' as  $+3$  to  $+12$  volts. Therefore the serial port can have a maximum swing of 24V. For data transmission lines (TxD, RxD and their secondary channel equivalents) logic one is defined as a negative voltage and logic zero is positive.

Control signal is show below in figure 6.1.2.1. It will be between +3 to +15 volts. The inactive state for these signals is the opposite voltage condition, between -3 and -15 volts.

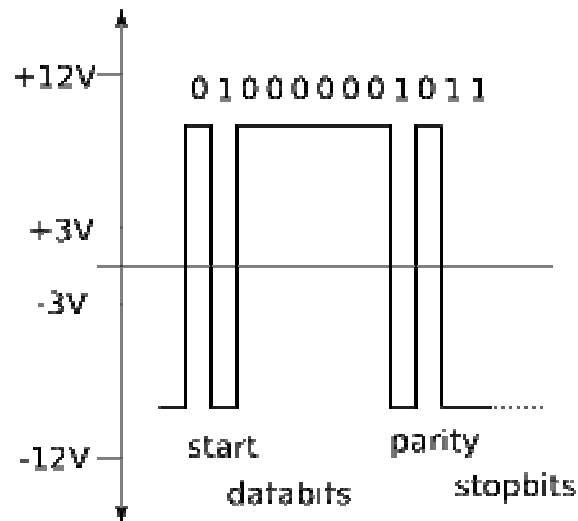

**Figure 6.1.2.1 RS-232 Control Signal**

## 6.2 Speaker Recognition Subsystem

### 6.2.1 Microphone Pre-Amplifier and High-Pass Filter

A previous prototype of the speaker recognition subsystem wasn't a DSP implementation but just utilized the MSP430G2553 MCU of the MSP430G2 value-line series of low-power MCUs. It was based on a previous project that used the MSP430F449 to record audio to a SD memory card and replays it on powered PC speakers.

Accepting speech input on MCUs poses some problems, however.

Because the MSP430 series of MCUs doesn't have a microphone input built-in on any model, an alternative method of input is to use any of the many channels of analog-to-digital converters (ADC) available on most devices. In the case of the MSP430G2553, which is as of this moment the most powerful MCU in the G2 ultra low power series of MSP430 MCUs, there are 8 channels of ADC available on pins P1.0 through P1.7. This solved the problem of accepting microphone input.

The second issue that arises from using this method is the weak speech input signal coming straight from the microphone.

The below figure demonstrates the need for an amplified microphone input as opposed to a straight signal. The amplifier also zeroes the signal, referencing the lowest input voltage with zero while referencing the highest input voltage to the provided supply voltage.

## Working with microphone output

An op-amp amplifies the mic output.

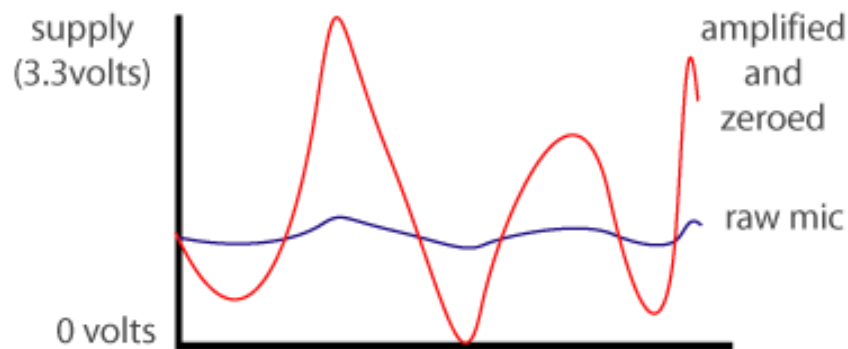

Ian Lesnet

**FIGURE 6.2.1.1: Comparison of straight (“raw”) microphone input and amplified, filtered and zeroed source**

A third issue is that of background noise. Naturally background noise is present in all settings, even if it is a miniscule amount. A simple, but incomplete fix for this is to use a thresholding method to allow only input above a defined threshold to be processed by the MCU.

This is very possible because of the nature of ADC.

The below figure best illustrates the method of converting analog input to digital input. Given an input voltage at a certain time T, we obtain a ratio of input voltage to reference voltage of

$$Ratio = \frac{V_{in}}{V_{ref}}$$

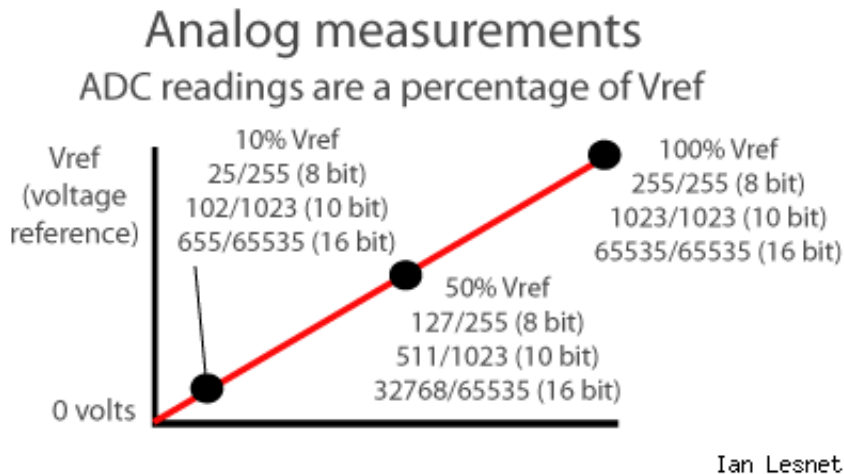

**FIGURE 6.2.1.2: Output of ADC; comparison of digital representation to voltage levels**

We determine the maximum integer amount that can be obtained from the ADC bit. Lengths can be either 8-, 10-, or 16-bit ADC (labeled ADCX where X is the length of conversion). MSP430G2553 has a 10-bit ADC (ADC10). As shown in the above figure, 8-bit can have 256 values (0-255), 10-bit can have 1024 values, and 16-bit can have 65,536 values. ADC8 is the lowest quality converter available, while ADC16 is the highest quality converter available.

To obtain the digital value of the input voltage  $V_{in}$  at a particular time T (hence  $V_{T,in}$ ) we simply multiply the ratio obtained earlier by the maximum value possible for the bit-sizes for the ADC. Obtaining the value at a particular time for the MSP430G2553 is accomplished by multiplying the ratio by 1023, or

$$S_T = (bit\ string) \frac{V_{T,in}}{V_{ref}} * 1023$$

where  $S_k$  is the bit string obtained at time T.

## 6.3 Electric Door Latch Subsystem

### 6.3.1 Door Strike Function

The table 6.3.1 listed all possible function of door strike. It is basically listed in four states: PIC output, Idle condition N.O, invalid used N.O. and valid user contact close.

DOOR STRIKE FUNCTION				
PIC Output	Controller Board Status	Door System Condition	Door Strike	User State
Idle condition N.O.	Controller fails to energize circuit	Door remains secure	Not actuated	Not allowed access
Invalid User N.O.	Controller fails to energize circuit	Door remains secure	Not actuated	Not allowed access
Valid User Contacts Close	Controller energizes circuit	Door allows access	Door actuated	User allowed access

**TABLE 6.3.1: DOOR STRIKE FUNCTION**

### 6.3.2 Communications

The electric door latch subsystem communicates with the PIC microcontroller via twisted pair change of state wiring. In the event that the N.O. pair changes state and shows continuity (closes), a relay on the electric latch control board changes state and the power supply delivers rectified DC voltage to the electric latch for a field adjustable time duration.

## 6.4 PIC Subsystem

Construction and coding for the PIC subsystem will take place in three phases: programming, building a prototype circuit, and constructing the final printed circuit board. Programming will consist of developing the code to be burned into the microcontroller's memory. This will need to be completed as early as possible so

that there is ample time to address problems identified during testing. The code will undoubtedly be modified throughout the semester as problems are discovered, but it is important to have a functioning base to work with as early as possible. Once the program is written, a simulation circuit will be built using the purchased development board and a peripheral breadboard. This allow for adjustments to be made to the circuit if problems should arise before ordering the printed circuit board. Once all the kinks have been worked out, the printed circuit board will be ordered and put together. Provided below is a more detailed description and the primary objectives of each of these phases for construction and coding.

## 6.4.1 Programming

The objective of programming is to quickly develop code that will provide the basic functionality to meet the specifications of this project. When the fundamental code is complete and functions correctly, additional features can be developed if time allows. The initial code will be developed quickly. Because of this, it is unlikely to be efficient and will likely lead to processing delays. If time permits, the code will be cleaned up to minimize processing delays and increase readability. As the system is designed now, there is no mechanism for handling multiple attempts for access at the same time. If two users bring their cards in range of the receiver at the same time, it is unclear how the system will respond. Implementing a solution for multiple card access through the use of delays or deactivating the card reader for a period of time is a top priority. Another feature that could be added is a penalty for failed voice matches. If a user cannot provide a valid voice sample in a given amount of time or in a certain number of attempts, their card should be deactivated and restricted from access for a certain period of time. Programming will continue throughout the construction of the project in an effort to implement these features, but the goal for this first phase of construction for the PIC subsystem is to provide functioning code as early as humanly possible.

## 6.4.2 Prototype Circuit

Once the code has been developed to a point where it should provide the desired functionality, construction of the prototype circuit will begin. The primary reason for building a prototype circuit is to identify any flaws before ordering the printed circuit board. The prototype circuit will allow changes to be made on the fly as opposed to the printed circuit board, which is a bit more permanent. The prototype circuit will be built from the development board, which includes the necessary interface for connection with the programmer, and a breadboard, which will be used in place of the terminal blocks to form connections with the other subsystems. The prototype circuit will not be included in the final project. Its purpose is only to aid in designing the printed circuit board. It is not intended to develop into the circuit that will be used for the final project. When its purpose

has been served, the prototype circuit will be discarded in favor of the printed circuit board.

### **6.4.3 Construction of the Printed Circuit Board**

The printed circuit board will be based on the prototype circuit, but the two circuits will not be identical. For instance, the connection for the programmer is built into the development board that will be used. This connection will have to be built into the printed circuit board even though it will not be based on the design of the prototype circuit. Another difference between the prototype circuit and the printed circuit board will be the connection to the power supply. The development board used in the prototype circuit has its own power supply and will not connect to the external power supply to be used by the printed circuit board. The connection to the external power supply will not be part of the prototype circuit, but it will have to be considered as part of the final design of the printed circuit board.

As for physically constructing the printed circuit board, it is a relatively simple process. The process starts with downloading the PCB Artist software from the Advanced Circuits website ([www.4pcb.com](http://www.4pcb.com)). The PCB Artist software is used to design the schematic diagram and the printed circuit board layout. Once the design is complete, it is submitted to Advanced Circuits when ordering the board. The board will ship approximately five days after it is ordered and should be delivered soon after. When the board arrives, the microcontroller, terminal blocks, and various other electrical components will be soldered to the board using tools in the senior design lab. The necessary connections will be made to the board, the microcontroller will be programmed with the final code, and the project will be complete.

## **7. PROJECT PROTOTYPE TESTING**

We will build our functional prototype, and will test each subsystem of our design both for individual functionality, as well as when each subsystem is working together. During this stage we will have most of our parts needed. It is also very likely that during this stage we will both break subsystems and have to redesign certain methods. For this season, when we researched parts, as long as they are decently inexpensive, we will order more than we need, just in case we break a component.

## 7.1 Card Reader Testing

### 7.1.1 Test Environment

When testing the read range, hold the card facing the reader. Optimum read range is achieved when the access card is presented face on, and parallel to the reader face. Move the card toward the reader very slowly from approximately three feet away. Moving slowly allows the card to be read at the same distance every time. It also allows different card ranges to be compared. Present an ID card to the reader. If the card ID number is found to be present in the PIC list, the reader LED will momentarily turn green and flashing while the beeper beeps once indicating that the card was read successfully. If the card ID is not present in the PIC list; the reader LED will remain red. The operation of the LED is controlled by the PIC. Normally The LED is controlled by the internal reader firmware.

When the PIC microcontroller receives the data from the reader, its software begins the process of deciding whether or not to grant access. This is usually done in several stages.

Does the length of the data format match what the controller is expecting? PIC microcontroller is designed to only accept a 26 bits length of data. If the data from the card is too long or too short, the PIC microcontroller may ignore it completely. Other PIC microcontroller may have a special “access denied” for a non-matching format length.

Does the format structure make sense to the controller? If the length is acceptable, the controller then breaks the binary string down into its component parts. These might include: Voice Profile, card number

Does the voice profile match? The controller will examine the data to determine if the Voice profile portion matches the one that has been programmed into the PIC microcontroller. If the Voice Profile doesn't match, access will be denied.

Is the Card Number within the allotted range? If yes, the decision process will continue. If no, access will be denied.

Is the Card Number in memory? If yes, the process continues. If no, access is denied.

The PIC microcontroller be decoded and acted upon. Only the PIC microcontroller is aware of the makeup of the format and whether the received data makes sense.

## 7.1.2 Test Cases and Results

Case 1: Hold UCF access card facing the reader. Nothing changes on reader.

Case 2: Hold a regular parking card facing the reader. Nothing changes on reader.

Case 3: Hold ProxCard II, which design to use facing the reader. Lights will turn on along with a beep indicated the data has transmitted.

## 7.2 Speaker Recognition Testing

### 7.2.1 Test Environment

In order to test the robustness of the chosen feature selection and pattern matching methods, the testing environments (chosen within reasonable boundaries of our proposed system application – it will never be used in an area of high vehicle traffic) can be in or simulate the following conditions:

- A quiet room with almost no ambient noise.
- A typical office setting with telephones quietly ringing in background.
- A classroom setting with multiple students speaking at the time of testing.

The speaker's mouth should be within the range of approximately 4 to 12 inches away from the microphone while the passphrase is being spoken. Before the passphrase is spoken, the speaker should also wait for the PIC subsystem-controlled LED to light, indicating the system is ready for a speech input.

Providing speech input at different distances from the microphone can also provide the optimum distance at which to say one's passphrase.

During the training stage, the speaker should have said his/her passphrase multiple times at the same word length and pitch as much as possible. During testing and simulation the same speech pattern should be repeated for the spoken passphrase to obtain a high probability of passing the verification process.

After the trimming, windowing, selection and matching processes a verdict should be achieved. An output of 1 will effectively inform the PIC subsystem that the claimed identity of the speaker matches the voiceprint identity. A continuous output of 0, on the other hand, will constitute a failure to match the identities. The output will remain a zero for as long as a match is not reached; even during idle times (output of zero is close to zero volts to the PIC subsystem).

Ambient noise, if present, should be insignificant enough such that the power spectrum of the voice sample is not adversely affected in a way that causes mismatches. We'll now examine the test cases and the expected results that can occur during the testing phase. Here we see a simple diagram outlining the basic structure of the code. The speaker recognition subsystem will idle while receiving an input of "000" from the PIC subsystem. It will continually check the input until it receives the UserID. Upon receiving the ID, the speaker subsystem will obtain from a database-like structure the voice profile of the given UserID. The data type of the profile is yet to be determined, but will most likely be in the form of an int array. Once the profile has been obtained from the database, the subsystem will activate the microphone and await for speech input. The speech input will be in the form of an int array representing amplitudes.

After trimming and thresholding to remove excess background noise, the received speech input will be accepted as an argument for the feature selection function. The function will return a set of features (of data type yet to be determined). The features will then be passed to a pattern matching function along with the database profile. The profile and features selected should be of the same data type. If enough features match the profile of the user, the subsystem will return a "Match", translating to sending a "1" to the PIC subsystem. However, if not enough features match the given profile, it will return a "Mismatch", sending a "0" to the PIC subsystem. Passively, while the speaker recognition subsystem is idle, senses a mismatch, or is processing the speech input, it will always output a "0" (mismatch) to the PIC subsystem.

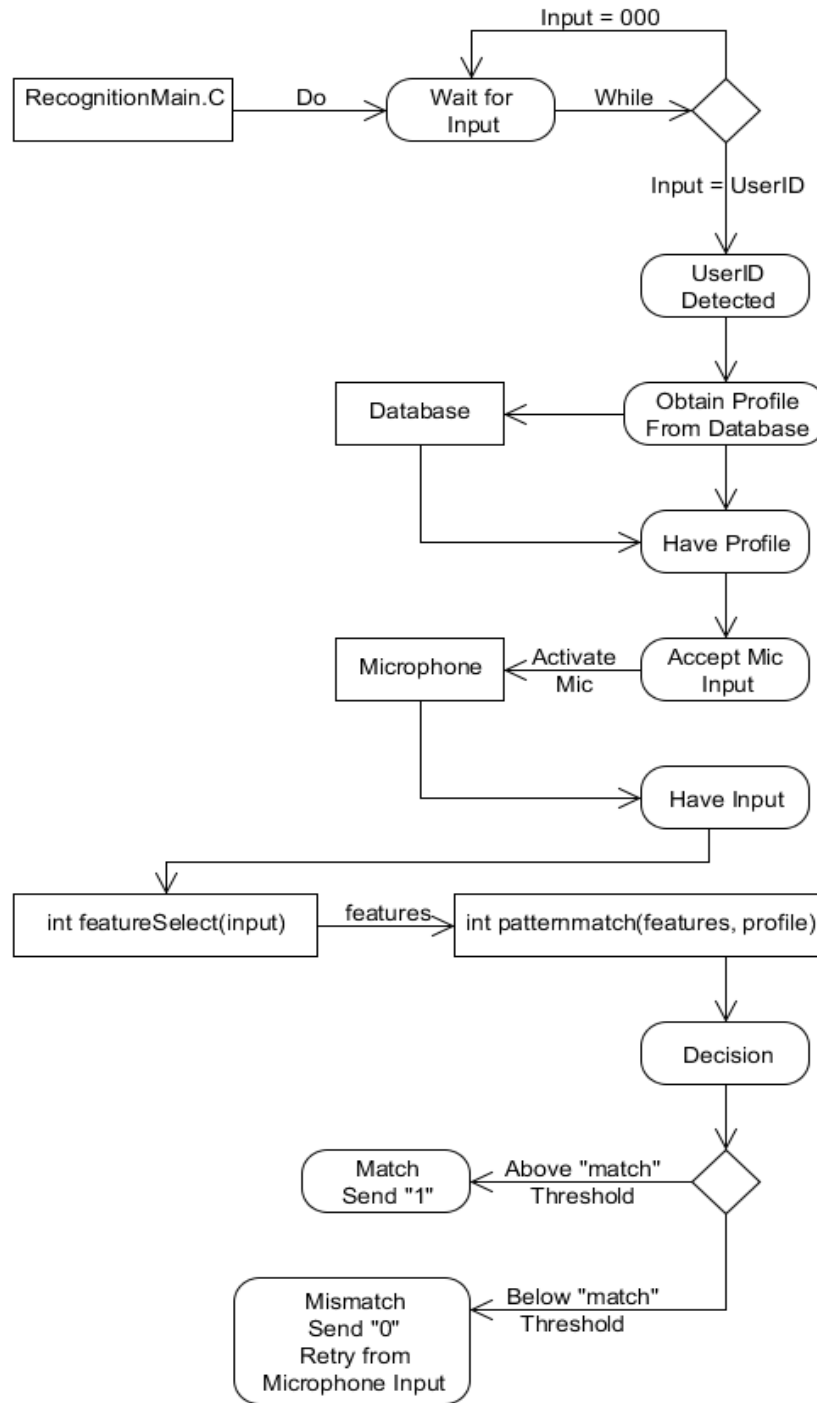
**FIGURE 7.2.1: SPEAKER RECOGNITION FLOW CHART**

## 7.2.2 Test Cases and Results

For each environment listed in section 7.2.1

Case 1: The user speaks into the microphone without using his RFID card (as outlined in 7.1.2). No match.

Case 2: The user speaks into the microphone after using his RFID card and waiting for the LED indicator. Match.

Case 3: The user speaks into the microphone after using another RFID card and waiting for the LED indicator. No match.

Case 4: The user uses his RFID card and does nothing else. No match.

## 7.3 Electric Door Latch Testing

### 7.3.1 Test Independent of Other Systems

Following the of the door assembly by itself, testing must be accomplished insuring the complete system is operating per design and as specified in the order of operations. The correct operation concludes this full circuit test and insures complete project compatibility. Likewise, failure at this point in the procedure invalidates the integration as designed. Systems engineering approach utilizing fishbone analysis is required until resultant test is validated.

The testing of the door assembly is one of the most visible parts of the complete project and must be accomplished insuring the complete system is robust and capable of withstanding the interaction with the user. The testing will begin with a closed loop approach of actuating the board and verifying this circuit works initially independent of the other systems to instill confidence. Immediately following this test and check out this system should now be slaved to the rest of the project.

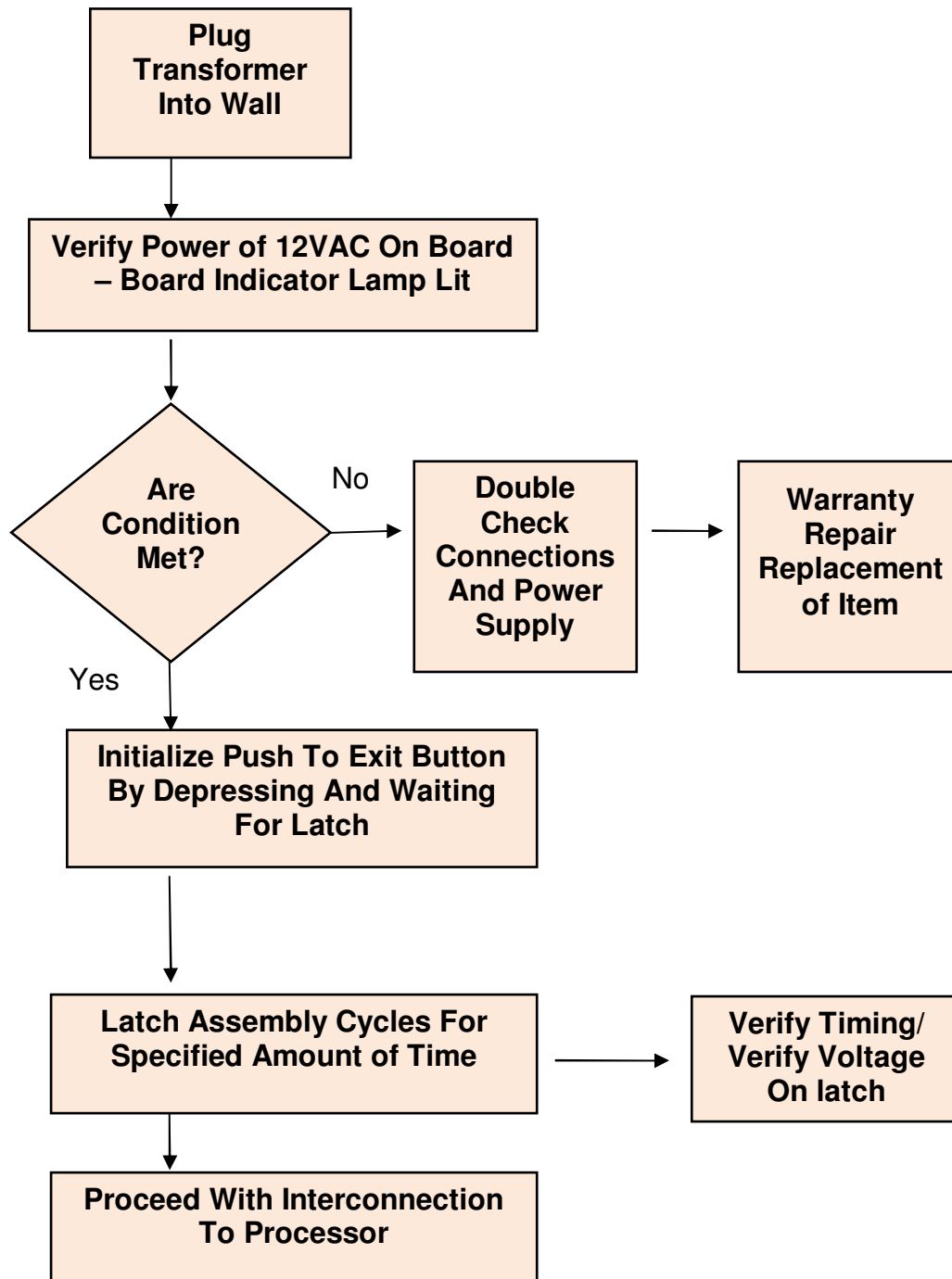

**FIGURE 7.3.1.1: INDEPENDENT ELECTRIC STRIKE FLOWCHART**

Following the of the door assembly by itself, testing must be accomplished insuring the complete system is operating per design and as specified in the order of operations. The correct operation concludes this full circuit test and insures complete project compatibility. Likewise, failure at this point in the procedure invalidates the integration as designed. Systems engineering approach utilizing fishbone analysis is required until resultant test is validated.

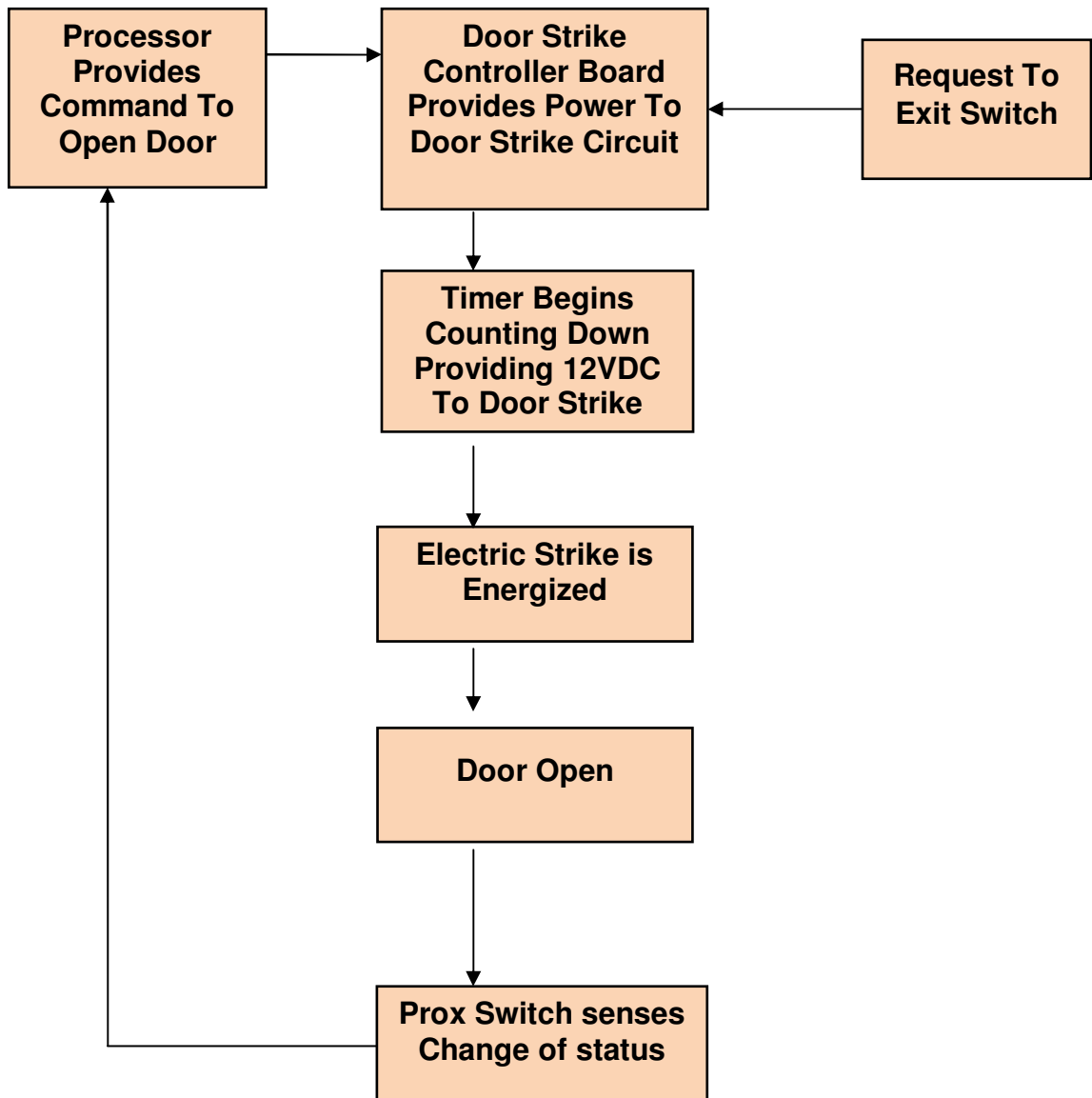

**FIGURE 7.3.1.2: ELECTRONIC STRIKE TEST DEPENDENT ON PROCESSOR**

## 7.3.2 Test Environment

When testing the door operator system, it must be insured that the output signal to door control board is satisfied (N.O. contact reads continuity – contacts provided by the processor are in a closed state). With voltage from power supply provided to control board, actuation of door strike should be applied. Potentiometer on control board will need to be adjusted for entrance timing. With door in open position and cycled close, door status switch should change states and report as closed (N.O. contacts will now read continuity to processor).

At this time, again cycle the processor circuit to allow energizing of door system for three cycles. Using infrared heat sensor, take a baseline temperature reading and record. Continue for 30 cycles and take another reading.

- Compare these temperature readings and ascertain if rise in operating temperatures is as expected for this number of cycles. Is temperature acceptable given circuit board ventilation?
- Does door latch operation change with this number of cycles? Is manufacturer lubrication acceptable?
- Check overall condition of all door system components. Based on observation is door system robust and acceptable given interactions with users?

## 7.3.3 Test Cases and Results

Case 1: No actuation from processor. Door remains secured.

Case 2: Incorrect RFID and / or Voice Actuation. Door remains secured.

Case 3: Correct information received from user. Door actuated from processor and door allows access.

Case 4: User desires exit. Either knob is turned or request to exit is actuated. Door strike allows exit and re-secures upon exit.

## 7.4 PIC Testing

The primary objective of testing the PIC subsystem is to ensure that all of the other subsystems are correctly integrated together and the final project functions as expected. Testing of the PIC subsystem will begin as early as possible, but it will be much more efficient if it is first confirmed that the other subsystems function as expected. That way, if an error is discovered, it will be clear that the

PIC subsystem is the one causing it and not one of the other subsystems. Pinpointing the cause of a problem quickly will significantly reduce the amount of time spent correcting the problem. Testing of the PIC subsystem will proceed in the following manner.

## 7.4.1 Test Environment

Testing for the PIC subsystem will be performed in a variety of ways and in a number of different environments. Testing will begin from the moment the first iteration of code is developed and will likely continue until the day before the project is presented. When the code is first developed, testing will be performed using the gpsim software. Testing will begin in this environment because a working circuit will not be available when the code is first completed. Since the circuit will not physically exist at that time, it will be necessary to simulate a circuit for the purpose of testing. The gpsim software will allow the contents of the registers to be micromanaged and will ensure the code is progressing as expected.

Testing will also be carried out with two separate physical circuits: the prototype circuit and the printed circuit board. When the prototype circuit is first completed, all testing successfully completed using the simulator will be repeated using the prototype. This will be done to confirm that the hardware connections are secure and functioning. All test cases will be run on the prototype board before ordering the printed circuit board. When the printed circuit board is received and constructed, all of the test cases will again be run for confirmation using the new hardware. This repetitive approach to testing should help catch some uncommon errors that might have otherwise slipped through the cracks without being noticed.

## 7.4.2 Test Cases and Results

There are eight possible cases for testing the PIC microcontroller are listed in table 7.4.2.

<b>Test Objective</b>	<b>Test Description</b>	<b>Expected Results</b>
1. Programming	Ensure the code is successfully loaded into the microcontroller's memory.	The code is successfully loaded into the microcontroller's memory.
2. LED Function	Ensure the LEDs on the card reader function as specified.	The LEDs on the card reader function as specified.
3. Valid/Invalid Card	Ensure the system can differentiate between a valid and invalid card.	The system differentiates between a valid and invalid card.
4. Speaker Recognition Profile Code	Ensure the system sends the correct profile code to the speaker recognition subsystem.	The system sends the correct profile code to the speaker recognition subsystem.
5. Voice Match Results	Ensure the microcontroller receives the correct match results.	The microcontroller receives the correct match results.
6. Electric Door Signal	Ensure the microcontroller provides an ample signal to unlock the door.	The microcontroller provides an ample signal to unlock the door.
7. Correct Door Status	Ensure the microcontroller has the correct status for the door at any given time.	The microcontroller has the correct status for the door at any given time.
8. Door Locked/Closed	Ensure the system recognizes the difference between a locked door and a closed door.	The system recognizes the difference between a locked door and a closed door.

**TABLE 7.4.2: PIC TEST CASES**

## 7.5 Total System Testing

In order for the devices used for the project to be properly tested and prototyped, each device must be prototype friendly. This means converting all microchips and other parts acquired to either a DIP standard packaging, or standard set of jumper wires. Smaller chips can be converted easily to a DIP with the purchase of a converter. Other chips may be harder to convert, requiring a separate PCB milled board with jumper outputs. In either case, each device's pin outs must be easily accessible and movable for quick development.

The door controller will require a lot testing, thus making prototyping a must for this device. This setup will most likely be composed of a series of breadboards, each for a separate chip, all mounted together on a piece of wood.

The completed design testing will be one of the last steps in the prototyping process. During this testing process, we will test the security hands free entry system in all aspects of our goal.

## 8. ADMINISTRATIVE CONTENT

### 8.1 Project Schedule

The below project milestone is a tentative schedule of the design process for the security hands free entry system. While it is accurate for the research data, some if it may change once we get into prototype testing. The first few months of senior design 1 was dedicated to researching different methods of implementing our design. This was including looking into the feasibility of what we are attempting to do, as well as reviewing similar projects by other people. The remaining months of the class were spent designing the project itself. Every member is responsible to oversee the progress of the other. This will ensure no delays in the long run of the project.

The project was distributed evenly between all the members of the team. The team had weekly meetings on Tuesdays and Thursdays and additional planned discussion days. Table 8.1.1 summarizes the milestone chart in senior design I that we have done.

<b>PROJECT MILESTONE- SD1</b>				
<b>Date</b>	<b>Anh Nguyen</b>	<b>Jordan Acedera</b>	<b>Christopher Spading</b>	<b>John E. Van Sickle</b>
9/27/2011	Proposal: Introduction/ Cost Analysis and Block Diagram Description	Proposal: Verifications, Testing Procedures, Block Diagram	Proposal: Introduction/ Block Diagram Description	Proposal: Introduction/ Block Diagram Description
10/20/2011	Research Antenna System, Proximity Key, Reader	Research Voice Recognition	Research PIC Microcontroller	Research Electric Door Lock
10/25/2011	Prepare Table of Content	Prepare Table of Content	Prepare Table of Content	Prepare Table of Content
11/16/2011	Drafting report for WCF/Mentor Meeting	Drafting report for WCF/Mentor Meeting	Drafting report for WCF/ Mentor Meeting	Drafting report for WCF/ Mentor Meeting
12/5/2011	Finished SD1 Paper	Finished SD1 Paper	Finished SD1 Paper	Finished SD1 Paper

**TABLE 8.1.1: PROJECT MILESTONE SD1**

The expected duration for each stage of our project for senior design II is depicted in table 8.1.2 below which we wish to use as a guide of goals. The primary focus will be the Speak recognition circuit and PIC microcontroller circuit. This will consist mostly of using multisim simulations as well as testing code in C. The start of senior design 2 will be spent ordering parts and beginning the prototype stage. The later end of the class will be used testing and possibly redesigning certain parts when needed.

<b>PROJECT MILESTONE SD-2</b>				
Date	Anh Nguyen	Jordan Acedera	Christopher Spading	John E. Van Sickle
1/15/2012	Order Card Reader, Reader converter, Tags	Order Voice Recognition System	Order PIC Microcontroller System	Order Door Hardware System
	Test Antenna/Help Programming Microcontroller	Begin designing the Voice Activation	Programming Microcontroller	Begin designing the Electric Door Lock
	Test Card Key/Help Program Microcontroller	Continue designing Voice Activation	Programming Microcontroller/ Helping Test	Programming Microcontroller/ Helping Test
	Test Reader	Continue designing Voice Activation	Finish Programming Microcontroller	Programming Microcontroller/ Helping Test
	Assist with Voice and Microcontroller Testing	Complete Voice Recognition	Testing Microcontroller	Testing Electric Door Lock
	Mock Up Demos	Mock Up Demos	Mock Up Demos	Mock Up Demos
	Assemble All Parts Together	Assemble All Parts Together	Assemble All Parts Together	Assemble All Parts Together
	Testing/Debugging	Testing/ Debugging	Testing/Debugging	Testing/Debugging
	Testing/Debugging/ Start Presentations	Testing/Debugging/ Start Presentations	Testing/ Debugging/ Start Presentations	Testing/ Debugging/ Start Presentations
	Finish Presentation/ Start Papers	Finish Presentation/ Start Papers	Finish Presentation/ Start Papers	Finish Presentation/ Start Papers
	Finish Final Papers	Finish Final Papers	Finish Final Papers	Finish Final Papers

**TABLE 8.1.2: PROJECT MILESTONE SD2**

## 8.2 Budget and Finance Discussion

Our bill of materials will serve as our estimate of how much we were going to spend in materials when designing and building a functional prototype. While the following table includes most of the important parts, it cannot take into consideration parts required from redesign and breakage. We are bound to most likely break something when designing this and will likely require us to go out and purchase another of the same part. There is also likelihood that we will redesign some parts of the system while in the prototype stage. The following table gives a brief baseline of how much we should spend. Though our aim is to keep the project “cost effective” like every company does with any product they develop, we will not skimp on parts in order to save a few bucks. Since this is a learning experience, and one we would like to take full advantage of, and using cheap parts that break or don’t work upon arrival.

The Security Hands Free Entry System had four main subsystems that were designed. The four subsystems of the Security Hands Free Entry System are the card access control, electronic lock, speaker recognition and PIC microcontroller. A total of \$3296.02 was baseline estimated to design and development these subsystems. The expected costs of the components are described in the following section.

## 8.2.1 Card Access Control Subsystem

The card access control subsystem contained a few number of electrical components and was one the simplest of the whole system. The baseline costs of the card access control subsystem are listed in table 8.2.1.

<b>Parts</b>	<b>Quantity</b>	<b>Unit Price</b>	<b>Price</b>
Card Reader			
Long Range Reader	1	450.00	450.00
Tag	4	15.00	60.00
Power Supply	1	25.00	25.00
Reader Converter	1	175.00	175.00
Wire (lot)	1		0.00
Connector	2	5.00	10.00
Tax	1	6.50%	46.80
Shipping & handling	1	1.00	50.00
Sub Total	1	1.00	816.80

**TABLE 8.2.1: CARD ACCESS CONTROL COST**

## 8.2.2 Electronic Door Subsystem

The electronic door subsystem was the second least expensive system. The baseline costs of the electronic door subsystem are listed in table 8.2.2.

<b>Parts</b>	<b>Quantity</b>	<b>Unit Price</b>	<b>Price</b>
Electronic Door Hardware			
Electrified Hinge	1	205.00	205.00
120 v to 12 v transformer	1	25.00	25.00
Software Coordination	Lot	5.00	5.00
Access control/electric strike/mag lock timer Module	1	15.00	15.00
Misc. wiring & parts	Lot	10.00	10.00
Magnetic contact/prox switch	1	5.00	5.00
Push to exit switch	1	15.00	15.00
Misc. cabling & parts	Lot	90.00	90.00
Demonstration Door frame assembly	Assy	150.00	150.00
Hardware / door knob, etc.	Lot	15.00	15.00
Door Operator to PIC Integration	Lot	55.00	55.00
Tax	1	6.50%	38.35
Shipping & Handling	1	1.00	100.00
Sub Total	1	1.00	728.35

**TABLE 8.2.2: ELECTRONIC DOOR COST**

## 8.2.3 PIC Microcontroller Subsystem

The PIC Microcontroller subsystem was very similar to the speaker recognition system in terms of design and complexity. The PIC Microcontroller was the least expensive subsystem. The baseline costs of the PIC Microcontroller subsystem are listed in table 8.2.3.

<b>Parts</b>	<b>Quantity</b>	<b>Unit Price</b>	<b>Price</b>
PIC Microcontroller			
Programmable Circuit Board	1	39.60	39.60
PIC16F877A (Microcontroller)	2	24.00	48.00
PIC16F877A Development Board	1	40.00	40.00
Dip Switch	1	5.00	5.00
CR2032 3V Lithium Battery and Clip	1	5.00	5.00
Reset Switch (Pushbutton)	1	2.00	2.00
PCB Board	1	35.00	35.00
Red LED	1	1.00	1.00
Green LED	1	1.00	1.00
Female RS-232 Connector	2	5.00	10.00
Wire and other Misc. Parts	1	25.00	25.00
PCB Assembly	1	50.00	50.00
Tax	1	6.50%	11.48
Shipping & Handling	1	1.00	50.00
Sub Total	1	1.00	288.08

**TABLE 8.2.3: PIC MICROCONTROLLER COST**

## 8.2.4 Speaker Recognition Subsystem

The speaker recognition subsystem was the most expensive of all the security hands free entry system. This subsystem was the most complex of all other subsystems. The baseline costs of the speaker recognition are listed in table 8.2.4

<b>Parts</b>	<b>Quantity</b>	<b>Unit Price</b>	<b>Price</b>
Speaker Recognition			
MSP430 Microcontroller Kit "LaunchPad"	2	4.30	8.60
TMS320 VC5510 DSP Starter Kit	1	395.01	395.01
DSPGlobal IS-232 UART RS232/422 Daughtercard	1	149.00	149.00
SoftBaugh ES449 Demo Board	1	199.00	199.00
Standard DB9 Serial Cable	1	10.00	10.00
Images SI Speech Recognition Kit (Unassembled) SR-06	1	114.95	114.95
NetBook	1	400.00	400.00
Board Assembly	1	50.00	50.00
Tax	1	6.50%	86.23
Shipping & Handling	1	1.00	50.00
Subtotal			1,462.79
Total			3,296.02

**TABLE 8.2.4: SPEAKER RECOGNITION COST**

## 8.3 Sponsors

This portion of the Administration chapter is dedicated to those who supported the group in any aspect and capacity. The Security Hands Free Entry System group would like to give thanks to the follow people (in no special order):

### **Dr. Samuel Richie of the University of Central Florida**

Dr. Richie is our professor. He is our guideline for the project.

### **Dr. Michael Georgiopoulos, of the University of Central Florida**

Dr. Georgiopoulos has helped our group to grant an allowable budget roughly of \$3300.00 from Work Force Central Florida sponsor program.

**Work Force Central Florida has sponsored our senior project.**

### **Mr. Sean P. Wick of HDR Inc**

Mr. Wicks is professional security physicals and very knowledgeable in homeland security field. He has provided many common and ideas in the card access control system.

### **Mr. Herb Gingold of Texas Instruments.**

Mr. Gingold has provided the free workshop at University of Central Florida. MSP430 and Stellaris are very good application to use.

Finally, all the evenly contribution of each member in this group.

## 8.4 Ethical Consideration

Our design is only a prototype; however, because we desire to provide a project that would meet real world applications, we must research what the industry standards are. First and foremost of these concerns is safety. With the litigation that our society struggles with daily that is both costly and time consuming it is prudent that any design take this into account. Second to our safety is security. An appeal to our product would be to upgrade an existing application that is not meeting the user's current needs. We must provide comparable security to the system that we wish to replace. Third and lastly is the economic / interchangeability of our product. Most likely an existing system will be retrofitted to ours. If this is too cumbersome and time consuming to implement then it will never be realized as a viable improvement.

To assure ourselves that we are moving towards the objectives above, certain readily available industry standards were researched. The most immediately recognized authority on exit/entrance devices would be the prominent NFPA. The NFPA (National Fire Protection Association) Green Book on safety was the foremost resource considered when we initiated our design criteria. Specifically, NFPA 101, Life Safety Code, Section 7.2.1.7.4 – Electric Locks was researched. The three main types of electric locks are electromagnet locks, electric bolt locks and electric strikes. The first two are not for use on doors used as points of egress. They have rigorous constraints placed upon them such as tie in to fire alarm, backup of power and timer requirements and were eliminated for our application early in the design process. Since the electric strike replaces the existing strike and still allows entrance and exit using the existing lockset it meets both the security and safety requirements mandated by this project.

An entity that is a sub category of the NFPA is the NEC or National Electric Code (NFPA 70). The NEC is consulted at the time of installation so that fire inspectors and insurance companies can be in agreement that your equipment was installed in workmanlike manner. Of special importance are circuits related to the control of building safety systems, door release devices and other low voltage security and life safety installations. Article 760 covers all of these and more.

When a facility is initially conceived or revised / updated, a specification must be followed. Therefore, architects and engineers utilize the 50 divisions of construction information, as defined by the Construction Specification Institute (CSI)'s Master Format. For our system the applicable division of these 50 would be Division 28 - ELECTRONIC SAFETY AND SECURITY. This is somewhat of a boilerplate outline of anything that these designers would expect of their contractors and vendors so that there is little confusion about what is to be delivered. In researching typical requirements during construction or renovation that would be placed upon our device we began to utilize the Division 28 documentation available as a benchmark to measure our project against. Additionally, as a vendor we searched out this same documentation to provide a testing outlines that would stand up to the rigors of the marketplace.

For individual components contained within ones security system, there is the UL Listing. The UL or Underwriters Laboratory lists items that have met their standards and testing. For example, in the case of the electric strike the item is listed for the temperature rating that it can sustain in the event of a fire at an egress point. Additionally, there is a test and standard for the pull force that someone could apply to an electric latch while still maintaining its integrity – generally 1200 lbs though there are companies currently at 1500lbs with a UL Listing for this rating. The UL Listing interests us greatly; however, they do not appear to be open source about their testing and practices and very little information was found on how to become compliant with their standards other than to note that a vendor had met their standard. Our stance was that if an item needed a UL Listing it might be most cost effective to purchase the item with the

listing already rather than trying to meet this illusive standard. The items that come readily to mind are electric strike, door and jamb and lockset hardware.

In this era that we live in nothing is done in a vacuum. One can do their research in advance or they can try to answer the myriad of questions that follow when they fail to. If they are fortunate they might have this opportunity. However, some parties find out once they are tied up in litigation after losses of property, or even life occur that they have caused these endangerments because they failed to comply with the many standards that exist for our societies well being. It is our intent with this project to perform this due diligence and to comply with these practices.

## 8.5 Project Summary and Conclusion

This project, being a heavily involved group initiative, required that each person achieve their individual goal and responsibility. The scope of this project is too much work for any one person, but when broken down across the talent of 4 capable engineers, it is well within reach. The individual assignments of each member included researching the function, designing a capable system, and methods of testing that function. The subsystem assignments and member responsibilities are shown in the previous section. Each group member was responsible for the individual research for their section. We met weekly on Tuesday and Thursdays to ensure that the project was progressing and that we were all working toward the same goal. From the beginning we had established both an email group to communicate on daily and a hotmail website [ucfseniordesign@hotmail.com](mailto:ucfseniordesign@hotmail.com) to send all correspondence, instructor provided pdf's and funding forms, etc to in the event a classmate/member was unable to attend class and/or make a scheduled meeting. This email correspondence has become an invaluable tool as both the end of the first semester approached and holiday campus closures have begun. This use of the emails meant that we had to communicate in a more one dimensional dialogue resulting in our realization that our paper needed more diagrams and illustrations and their accompanying descriptions to convey our ideas. We believe that both our paper and our project profits from this added depth of communication. Additionally, because each individual part of the project is dependent upon the rest of the pieces, we had to make sure during both our meetings and our email correspondence that each member was informed by the others how they were planning to design certain things. This kept us from researching things that would not have made sense because they wouldn't work together. The report represents our design plan and how we will build this project. We realized early in the project that development of one list of milestones and goals for the group was the most effective way for the group to be consistently productive individually. This will be similarly followed for the second semester as well, as there will surely be much to do. The project group plans to move forward in a similar fashion with the remainder of the project. There are always unforeseen things that will happen when building a

prototype and during this, we will probably have to redesign some parts. Though we may end up changing some of the design, the core requirements should still be met. This means we will not stray from our own specifications just because something did not work on the first attempt. The design stages and acquisition of parts for the build process have already begun and as we move forward we desire to continue our success into the development and build. We will continue to accumulate our spares on-hand while items still required for procurement, development tools and software necessary for the project build will continue to be specified and purchased as well as parts and materials for building of enclosures for the units. This project will be a difficult undertaking for the group and should be a worthy test of the skills that we've obtained over the years. We want to thank Dr. Richie for both his valuable constructive input and his candid critical eye and we endeavor to utilize this and our mentor's much respected field knowledge to put forth a project worthy of this partnering.

## 9. APPENDICES

### I. WORKS CITED

#### a. Card access Control system

<http://www.hidglobal.com/products/readers.php>

[http://en.wikipedia.org/wiki/Radio-frequency\\_identification](http://en.wikipedia.org/wiki/Radio-frequency_identification)

<http://www.technovelgy.com/ct/Technology-Article.asp?ArtNum=47>

[http://en.wikipedia.org/wiki/Wiegand\\_interface](http://en.wikipedia.org/wiki/Wiegand_interface)

[http://docs.tibbo.com/taiko/index.html?ser\\_clockdata\\_mode.htm](http://docs.tibbo.com/taiko/index.html?ser_clockdata_mode.htm)

[http://en.wikipedia.org/wiki/Wiegand\\_interface](http://en.wikipedia.org/wiki/Wiegand_interface)

[http://en.wikipedia.org/wiki/File:Rs232\\_oscilloscope\\_trace.svg](http://en.wikipedia.org/wiki/File:Rs232_oscilloscope_trace.svg)

<http://proxclone.com/wiegand.html>

<http://www.arcelect.com/rs232.htm>

<http://www.beyondlogic.org/serial/serial.htm>

<http://www.lammertbies.nl/comm/cable/RS-232.html>

[http://www.rfideas.com/products/wiegand\\_converters/wiegand\\_to\\_serial/index.php](http://www.rfideas.com/products/wiegand_converters/wiegand_to_serial/index.php)

#### b. Door Lock system

[http://www.youtube.com/watch?v=X7U6rrTPe-U&feature=player\\_embedded](http://www.youtube.com/watch?v=X7U6rrTPe-U&feature=player_embedded)

[http://www.vonduprin.com/prod\\_strikeforce.asp](http://www.vonduprin.com/prod_strikeforce.asp)

<http://www.vonduprin.com/pdf/Security.pdf>

[http://en.wikipedia.org/wiki/Electric\\_strike](http://en.wikipedia.org/wiki/Electric_strike)

<http://www.hesinnovations.com/en/site/hesinnovations/Support/General-Education/FAQs/>

<http://www.nokey.com/elstrikandma.html>

<http://www.grainger.com/Grainger/security-doors/door-and-door-frames/security/ecatalog/N-b6c>

<http://www.ebay.com/sch/i.html?from=R40&trksid=p3984.m570.l1313&nkw=electric+strike&sacat=See-All-Categories>

<http://www.ul.com/global/eng/pages/offerings/industries/lifesafetyandsecurity/securityandsignaling/>

<http://buildipedia.com/knowledgebase/division-28-electronics-safety-and-security>

<http://www.securitysales.com/Channel/Intrusion/Articles/2007/02/Complying-With-Key-Points-of-National-Electric-CodeNFPA-70.aspx>

<http://www.youtube.com/user/HESinnovations#p/u/1/MJO8iqSUH3s>

<https://www.jlmwholesale.com/images/Top10.pdf>

<http://rubecom.us/fail-safe-and-fail-secure-electric-locking-devices.htm>

<http://www.keylessamerica.com/product-p/hes%205000.htm>

[http://www.buyelectricstrikesonline.com/orderinfo.asp?url=http://www.adamsrite.com/NewFiles/prod\\_electricstrike.htm&sn=Adams%20R](http://www.buyelectricstrikesonline.com/orderinfo.asp?url=http://www.adamsrite.com/NewFiles/prod_electricstrike.htm&sn=Adams%20R)

<http://www.handlesets.com/von-duprin-6214-9-electric-strike-for-single-door-application-mortise-and-cylindrical-exit-device->

### **c. PIC Subsystem**

<http://www.wisegeek.com/what-is-a-microcontroller.htm>

<http://www.instructables.com/id/How-to-choose-a-MicroController/>

<http://www.ti.com/lit/ds/symlink/msp430g2231.pdf>

<http://www.datasheetcatalog.org/datasheet/atmel/2486S.pdf>

<http://ww1.microchip.com/downloads/en/devicedoc/39582b.pdf>

<http://www.ccsinfo.com/content.php?page=compiler-details>

<http://sdcc.sourceforge.net/>

<http://ww1.microchip.com/downloads/en/devicedoc/51553e.pdf>

<http://www.ebay.com/itm/New-PIC-Development-Board-PIC16F877-PIC16F877A-/270745410796>

<http://www.sunstone.com/>

<http://www.pcbexpress.com/index.php>

<http://www.expresspcb.com/>

<http://www.4pcb.com/>

[http://www.ehow.com/facts\\_5668923\\_terminal-block\\_.html](http://www.ehow.com/facts_5668923_terminal-block_.html)

<http://www.poweredusb.org/whatisusb.html>

#### **d. Speaker Recognition**

[Sigurdsson, Sigurder, Kaare Brandt Petersen, and Tue Lehn-Schioler. "Mel Frequency Cepstral Coefficients: An Evaluation of Robustness of MP3 Encoded Music". \*CiteSeerX\* 3.0 \(2006\). \*The Pennsylvania State University\*. Web. 4 December 2011.](#)

[Cinneide, Alan O., David Dorran, Mikel Gainza, and Eugene Coyle. "Linear Prediction, The Technique, Its Solution, and Application to Speech". \*http://eleceng.dit.ie\*. Dublin Institute of Technology – School of Electrical Engineering Systems, August 2008. Web. 3 December 2011.](#)

[Hasan, Rashidul, Mustafa Jamil, Golam Rabbani, and Saifur Rahman. "Speaker Identification Using Mel Frequency Cepstral Coefficients". \*3<sup>rd</sup> International Conference on Electrical and Computer Engineering\* \(2004\): 565-568. Web. 3 December 2011.](#)

[Sarosi, Gellert, Mihaly Mozsary, Peter Mihajlik, and Tibor Fegyo. "Comparison of Feature Extraction Methods for Speech Recognition in Noise-Free and in Traffic Noise Environment". \*IEEE Xplore\* \(2011\): n. pag. \*IEEE\*. Web. 3 December 2011.](#)

[Stamp, Mark. "A Revealing Introduction to Hidden Markov Models". \*CiteSeerX\* \(2011\). \*The Pennsylvania State University\*. Web. 20 November 2011.](#)

[Rabiner, L.R. and B.H. Juang. "An Introduction to Hidden Markov Models". \*IEEE ASSP Magazine\* January 1986: 4-16. Web. 21 November 2011.](#)

[Campbell, Joseph P. "Speaker Recognition: A Tutorial". \*Proceedings of the IEEE\* 85.9 \(1997\): 1437-1462. Web. 19 November 2011.](#)

[Wu, Randy. "Interfacing the MSP430 with a DSP Application". \*Application Report SLLA174\* February 2005. Texas Instruments. Web. 8 November 2011.](#)

["TMS320VC5510 DSK Technical Reference". October 2002. Spectrum Digital. Web. 8 November 2011.](#)

["User's Guide for MSP430F44X Evaluation System \(ES449\)". \*SoftBaugh.com\* 29 December 2004. SoftBaugh. Web. 8 November 2011.](#)

[Lesnet, Ian. "Record audio with the MSP430 microcontroller pt. 2". \*DIYLife.com\*. AOL Inc 16 May 2008. Web. 20 November 2011.](#)

[Raju, Murugavel. "Solid State Voice Recorder Using Flash MSP430". \*Application Report SLLA123\* January 2001. Texas Instruments. Web. 20 November 2011](#)

## II. PERMISSION

### a. Card Reader System

Knights Email Print Message

Page 1 of 1

#### Re: Requesting Permission to use Long Range Reader System Information

From: **Michael Klein** (MKlein@hidglobal.com)  
Sent: Tue 11/01/11 6:03 PM  
To: ncal@knights.ucf.edu  
Cc: Jeremy Hyatt (JHyatt@hidglobal.com); Mark Doi (MDoi@hidglobal.com)  
2 attachments  
proxcard-clamshell-new-brand-hi.jpg (571.5 KB) , maxiprox\_5375-hi.jpg (578.4 KB)

Hello Anh,

Mark had forwarded me you email and we'd be more than happy to help you with your project. I've attached the requested imagery but ask that you provide the proper accrediting and rules below along with a proof of the finalized copy/layout featuring our images and/or information you cite in your project.

1. Photo(s) must be credited "photo by HID Global Corporation"
2. HID Global Corporation must be mentioned in the accompanying text or article.
3. Images cannot be used for the promotion of products or technologies competitive to HID.

Please let me know if there is anything else we can provide you with, otherwise good luck with your project!

Cheers,

Mike

(See attached file: proxcard-clamshell-new-brand-hi.jpg)(See attached file: maxiprox\_5375-hi.jpg)

**Mike Klein**  
Global Public Relations  
Specialist

HID Global Corporation  
15370 Barranca Parkway  
Irvine, CA 92618  
949 732 2054 (Office)  
949 981 1099 (Mobile)  
[mklein@hidglobal.com](mailto:mklein@hidglobal.com)  
[www.hidglobal.com](http://www.hidglobal.com)



-----  
**Confidentiality Note:**

This message is intended for use only by the individual or entity to which it is addressed and may contain information that is privileged, confidential, and exempt from disclosure under applicable law. If the reader of this message is not the intended recipient or the employee or agent responsible for delivering the message to the intended recipient, you are hereby notified that any dissemination, distribution or copying of this communication is strictly prohibited. If you have received this communication in error, please contact the sender immediately and destroy the material in its entirety, whether electronic or hard copy. Thank you.

<http://sn112w.snt112.mail.live.com/mail/PrintMessages.aspx?cpids=b79821a2-04b3-11e1-...> 11/1/2011

## RE: Wiegand Converter - RS 232

From: **Koz Hood** (khood@rfideas.com)  
Sent: Wed 11/02/11 9:39 PM  
To: ncal@knights.ucf.edu  
Cc: TechSupport@RFIDeas.com

Hi Anh,

You can download the information on our wiegand to serial converter from our website at:  
[http://www.rfideas.com/products/wiegand\\_converters/wiegand\\_to\\_serial/index.php](http://www.rfideas.com/products/wiegand_converters/wiegand_to_serial/index.php).

Good luck with your project!

Thank you!

Koz

Koz Hood

**RF IDeas, Inc.**

*Single Badge Solutions for Identification and Access*  
www.RFIDeas.com  
(Office) 847-870-1723 X415  
(Fax) 847-483-1129

[khood@rfideas.com](mailto:khood@rfideas.com)

## b. Electric Door System

jevansickle@hotmail.com ·

To: benny\_t\_hu2855sjzg@members.ebay.com ✎ ✕

Subject: RE: Other: ucfengineering sent a message about Access control/electric strike/mag lock timer Module #200424979900

Insert: Attachments Office docs Photos From Bing Emoticons

Tahoma 10 B I U

---

**Dear ucfengineering,**

I already **sent** invoice and **instruction** to your email address.

Thanks  
benny

- bennytrade181

---

From: ucfengineering  
To: bennytrade181  
Subject: RE: Other: ucfengineering sent a message about Access control/electric strike/mag lock timer Module #200424979900  
Sent Date: Oct-17-11 17:55:07 PDT

**Dear bennytrade181,**

Push button is acceptable, price/terms are fine.  
I need specification sheets on these three items - can you pdf them to me.  
my email address for payment is jevansickle@hotmail.com <email address removed per policy>.  
**Please send item cut sheets to me as soon as possible - I will be sending payment at that time.**  
Thank you,  
John\_V