

The Wi-Fi Seeker

Senior Design I

Group #30

Fall 2014



UCF

Department of Electrical Engineering and Computer Science

University of Central Florida

Dr. Samuel Richie

Christina Leichtenschlag c.leichtenschlag@knights.ucf.edu

Adrian Morgan amorgan18@knights.ucf.edu

Jimmy Wong wongj92@knights.ucf.edu

Table of Contents

1.0 Executive Summary	1
2.0 Project Description	2
2.1 General Description	2
2.2 Motivation and Goals	2
2.2.1 Motivation	2
2.2.2 Goals.....	3
2.3 Requirements and Specifications	3
2.3.1 Android Application and Wireless Communication	4
2.3.2 Microcontroller and Sensors	4
2.3.3 Power	5
3.0 Research	6
3.1 Existing Similar Projects	6
3.1.1 KnightroKart.....	6
3.1.2 T-100 Watch Dog.....	6
3.2 Relevant Technology	7
3.2.1 Microcontrollers	7
3.2.2 Sensors.....	8
3.2.3 Robot Base.....	10
3.2.4 Motors.....	11
3.2.5 Motor Controllers	12
3.2.6 Remote Control System.....	14
3.2.7 Wireless Data Communication.....	16
3.2.8 Wi-Fi Signal Sensing.....	18
3.2.9 Video Streaming.....	19
3.2.10 IP Cameras.....	19
3.2.11 Potential Power Sources	20
3.2.12 Types of Rechargeable Batteries	21
3.2.13 Other Battery Considerations	23
3.2.14 Photovoltaic (PV) Cells	26
3.2.15 Maximum Power Point Tracking	29
3.2.16 Charge Controllers.....	30
3.2.17 Voltage Regulators	33
4.0 Hardware & Software Design Details	36
4.1 Initial Design Architectures and Related Diagrams	36
4.2 Sensors Subsystem	37
4.2.1 Infrared Proximity Sensor	37
4.2.2 Ultrasonic Proximity Sensor.....	37
4.3 Motion Subsystem	37
4.3.1 Motors.....	37
4.3.2 Motor Controller.....	37

4.4 Android Application Subsystem	40
4.5 Wireless Subsystem	46
4.5.1 Bluetooth Communication.....	46
4.5.2 Wireless Signal Sensing	48
4.6 Video Streaming Subsystem.....	48
4.7 Power Subsystem.....	49
4.7.1 Rechargeable Batteries	50
4.7.2 Solar Panel.....	52
4.7.3 MTTP Charge Controller.....	53
4.7.4 Power Conversion.....	56
5.0 Design Summary of Hardware and Software	60
5.1 Hardware	60
5.1.1 Specifications.....	60
5.1.2 Microcontroller	60
5.1.3 Bluetooth Module.....	60
5.1.4 Wireless Module.....	61
5.1.5 Camera.....	62
5.1.6 Sensors.....	62
5.1.7 Motor	64
5.1.8 Solar Panel.....	65
5.1.9 Power Supply.....	65
5.1.10 Robot Base.....	66
5.1.11 MSP430F5529 Connections.....	67
5.2 Software.....	68
5.2.1 Specifications.....	68
5.2.2 Android Application.....	68
5.2.3 Microcontroller.....	70
6.0 Project Prototype Construction and Coding.....	72
6.1 Parts Acquisition	72
6.1.1 Free Samples.....	72
6.1.2 Texas Instruments.....	72
6.1.3 Digi-Key	72
6.1.4 SparkFun Electronics.....	72
6.2 PCB Manufacturing and Assembly	73
6.2.1 4PCB.....	73
6.2.2 Express PCB.....	73
6.2.3 OSH Park.....	73
6.2.4 UCF Radio Club.....	73
6.2.5 TI Innovation Lab.....	73
6.3 Final Coding Plan.....	74
6.3.1 Android Application.....	74
6.3.2 Microcontroller.....	75

7.0 Project Prototype Test Plan	77
7.1 Hardware Test Environment	77
7.1.1 Motor Controller Tests	77
7.1.2 Sensors Tests	79
7.2 Hardware Specific Testing	80
7.2.1 Battery Life.....	80
7.2.2 Battery Charging.....	81
7.3 Software Test Environment.....	83
7.3.1 Phone	83
7.3.2 Tablet.....	83
7.4 Software Specific Testing.....	84
7.4.1 Wireless Module Tests	84
7.4.2 Bluetooth Communication Tests	85
7.4.3 Video Streaming Tests.....	86
7.4.4 Obstacle Avoidance Tests	87
7.5 Integration Testing.....	88
8.0 Administrative Content	90
8.1 Milestone Discussion	90
8.2 Finances and Budget Discussion	91
8.2.1 Project Sponsorship	91
8.2.2 Budgeting.....	91
8.3 Division of Labor	93
9.0 Project Summary	95
Appendix A - Copyright Permissions.....	96
Appendix B - Works Cited.....	104

1.0 Executive Summary

The idea for the Wi-Fi Seeker began small. Initially Group #30's design was a simple radio-controlled (RC) car that would use an Android device for a controller. This ended up being the very beginning and basis for what the Wi-Fi Seeker would become. First, the robot needed a purpose; it was actually the group's advisor, Dr. Samuel Richie, who proposed the idea of a robot that would seek out a wireless signal, with the purpose of identifying the location where the signal is strongest in an area.

Once the thought had been proposed, it was too good of an idea to not implement. Almost everyone who has ever used his/her laptop, smart phone, or other electronic that connects to the Internet via a Wi-Fi signal has stumbled across the issue where s/he is not getting a strong enough signal to establish a good connection. This often happens in public buildings because the user does not necessarily know where the nearest wireless router is. As of 2014 there are not a lot of options for people who want to measure a Wi-Fi signal. Other than the extremely vague Wi-Fi indicator, which is the dot with three curved lines radiating from it, where having all three lines is supposed to mean that a signal at its strongest and having none of the lines means the signal is at its weakest, there is no good method for determining Wi-Fi signal strength. Even this pictorial representation is not accurate to a science, and the user has no way of knowing exactly how strong his/her connection to the Internet is.

Thus the need is established for the Wi-Fi Seeker. The general premise of this project is that a robot will be built with the purpose of sniffing out a Wi-Fi signal. The robot will be controlled using an Android device that will communicate with the robot using Bluetooth. The Android application will allow the user to initiate the robot's autonomous functionality, as well as be the interface for how the user will see what Wi-Fi signal the robot is getting. Another feature that will be implemented is the ability for the user to "see what the robot sees", which will be achieved by mounting a camera on the robot and streaming the video feed from the camera to the Android application. Thus as the robot goes on its mission to find the strongest Wi-Fi signal, the user can watch from a first-person point of view. The IP camera will communicate with the Android device using Wi-Fi. As for the motor control, that will be implemented using two H-bridges that will be connected to the MSP430. Additionally there will be sensors on the robot to assist the autonomous functionality and allow the robot to avoid obstacles such as walls or drops. Finally, the robot will run off of lithium ion batteries that are recharged using solar panels. There will be a solar cell mounted on the top of the robot body, allowing the batteries to be recharged when there is a strong enough light source hitting the solar cell. The algorithm that the robot will implement once it enters its autonomous mode is as follows: the robot will identify the current signal strength of its Wi-Fi connection using a specific function on the wireless module. If the signal strength is not the maximum value, the robot must move and search for the location with the strongest signal. Should the robot move in a direction and the Wi-Fi signal strength decreases, it will move in the opposite direction; similarly if the robot moves in a direction and the Wi-Fi signal strength increases, it will continue to move forward. If the robot reaches a point where moving in any direction decreases the Wi-Fi signal strength, the robot has found the local maximum Wi-Fi signal strength in the area, and will cease its search. Since the Wi-Fi Seeker robot has been designed to be low power and will utilize solar energy, this project will be partially funded by Leidos Engineering.

2.0 Project Description

2.1 General Description

The Wi-Fi Seeker robot is a UCF Senior Design project. The purpose of this robot is to seek out a wireless signal to determine where it is strongest in an area. This will be accomplished using an autonomous algorithm and the robot's ability to determine the strength of a given wireless network. The robot will be equipped with sensors to allow it to detect and avoid obstacles as it implements its autonomous functionality. In addition, the robot will have other features, such as a video streaming system. This will allow the user to "see what the robot sees", by watching a video coming from a camera mounted on the robot. In order to view this video stream, an Android application will be developed for the Wi-Fi Seeker robot. This application will serve as the medium for control of the robot, and will have the ability to allow the user to either manually control the robot or start the robot's autonomous functionality, all the while allowing the user to watch the video stream being broadcasted by the robot. Another feature of the Wi-Fi Seeker robot will be its use of solar energy. The robot will be powered by lithium ion batteries, and the batteries will be able to be recharged using solar energy and the solar panel that will be mounted on top of the robot. This will allow the robot's battery life to be extended and for renewable energy to be used to recharge the batteries. This robot prototype will be built by two Electrical engineers and one Computer engineer in the Spring 2014 semester.

2.2 Motivation and Goals

2.2.1 Motivation

The motivation behind the Wi-Fi Seeker robot is personal. The members of Group 30 decided that they wanted to put their individual skills to practice, as well as learn new skills to develop themselves as engineers. They wanted this Senior Design project to combine all of their experience and knowledge of Computer and Electrical Engineering while pursuing new interest and knowledge. From an Electrical Engineering perspective, designing and implementing hardware is very important part of being a successful Electrical Engineer. From a Computer Engineering perspective, designing and implementing algorithms are an important part.

In order to accommodate the skill set and desire to learn of each member, it was decided to use a robotic vehicle as a base for this project. Using a robotic vehicle allows for the project to be very modular, where it is as simple as adding another subsystem to expand upon the functionality of the robot. With the ability to add any subsystem, the members could choose which skills they wanted to improve and then do so by implementing a related subsystem. By combining each group members' ideas with Dr. Samuel Richie's ideas, it was decided to build an autonomous vehicle that seeks out a Wi-Fi signal and could be recharged using solar energy. The Electrical Engineers will be able to apply the skills they have learned in theory and gain experience in fabrication. They will design and implement the motor, sensors, and power subsystems. The Computer Engineer will be able to gain experience in designing and implementing an autonomous algorithm, a mobile application, and working with network communications.

2.2.2 Goals

The main goal of this project is to create an autonomous robotic vehicle that is able to sniff out and determine the location where the connection to a given Wi-Fi signal is strongest. In addition, the user should be able to see what the robot is seeing, as well as having the ability to manual control the vehicle. Therefore the project will consist of the following objectives: Wi-Fi Seeking, Obstacle Avoidance, Autonomous Function, Remote Control, Video Feedback, and Solar Charging.

For the Wi-Fi Seeking function, the goal is to have the robot to scan an area for the location where its connection to the Wi-Fi signal is strongest. The user will first select a Wi-Fi signal, and then the robot will begin its mission of finding where the signal is strongest, which coincides with finding the location of the router. While tracking down the router, the robot must be able to avoid colliding with any obstacle along its path. This is where the goal of Obstacle Avoidance comes in; without it the autonomous Wi-Fi Seeking could not take place. Thus the robot will utilize the proximity sensors equipped on the perimeter of the robot, and when an obstacle is detected the robot must be able to find a different path to the router in order to continue.

While the main objective is for the robot to be autonomous, meaning that it will not need any user interaction to be able to complete its assigned task of Wi-Fi Seeking, there still needs to be some level of user interaction with the robot. This introduces the objective of Remote Control, which allows the user to have the option of controlling the robot via a mobile application. If the user should decide that s/he wants to control the robot manually, there will be a mode within the application where the robot will exclusively follow the user's commands.

The objective of Video Feedback ties in to the functionality of the Wi-Fi Seeker robot. Regardless of if the robot is autonomously completing its mission or if the user is remotely controlling the robot, the user will have the urge to see what the robot sees, so to speak. In order to accomplish this, a video stream will be implemented. This will allow the user to watch a video stream broadcasted from a camera mounted on the robot, and will serve the purpose of entertainment when the robot is in autonomous mode and of information when the user is controlling the robot in manual mode.

The final objective, Solar Charging, will equip the robot with a solar charging system. Since Wi-Fi signals are not limited to the indoors, the robot will be expected to perform in outdoor conditions as well. Having a solar charging system will allow the robot to function for a longer period of time, and in the case that the batteries run out of juice, the solar charging system will recharge the batteries so that the robot will eventually be able to complete its mission.

2.3 Requirements and Specifications

Once the idea of a Wi-Fi seeking robot was determined, the next step was to lay out the exact specifications as to what the robot was going to achieve. These requirements will be the expectations that the Wi-Fi Seeker will be expected to meet, and would be the basis for the test cases that the Wi-Fi Seeker will be tested against.

2.3.1 Android Application and Wireless Communication

The Wi-Fi Seeker will be driven by an Android application, which will be the controller for the user to give commands to the robot. The means of communication between the controller and the robot itself will be through Wi-Fi, which means that the Android device, the wireless module on the robot, and the IP camera will all need to directly connect to a Wi-Fi signal. The IP camera will transmit a video stream to the Android application separately from the communications between the MSP430F5529 microcontroller on the robot and the Android application. The requirements for the Android application, wireless communications, and video streaming are specified in Table 2.3.1.A below.

Table 2.3.1.A - Android Application and Wireless Communication Requirements

Requirement ID	Requirement Description
WFS-001	The robot will seek out a Wi-Fi signal.
WFS-002	The robot will have two modes: autonomous and user controlled.
WFS-003	During autonomous mode, the robot will stop when it determines that its current location is where the Wi-Fi signal is strongest.
WFS-004	The robot will notify the user when it has found the strongest Wi-Fi signal.
WFS-005	The Android application will be developed in Java for an Android device with operating system version KitKat.
WFS-006	The robot will be able to receive commands from the Android application using Bluetooth.
WFS-007	The Android application will display the current signal strength that the robot is receiving.
WFS-008	The Android application will allow the user to manually control the motion of the robot.
WFS-009	The robot will respond to the manual Bluetooth commands within 1 second of the user issuing the command.
WFS-010	The robot will be able to connect to a wireless signal using a wireless module.
WFS-011	The IP camera will be able to connect to a wireless signal.
WFS-012	The Android application will be able to communicate directly with the IP camera.
WFS-013	The Android device will display the video stream from the IP camera while the robot is functional.
WFS-014	The robot will be able to measure the strength of the wireless signal it is connected to.

2.3.2 Microcontroller and Sensors

The Wi-Fi Seeker will use the MSP430F5529 microcontroller mounted on the robot body in order to control the motion of the robot. Also mounted on the body of the robot will be sensors to aid in obstacle avoidance. The requirement for the robot chassis, sensors, and functions are specified in Table 2.3.2.A below.

Table 2.3.2.A - Robot Body and Functionality Requirements

Requirement ID	Requirement Description
WFS-015	The robot will be able to move forwards and backwards.
WFS-016	The robot will be able to turn left and right.
WFS-017	The robot will have collision avoidance to avoid hitting obstacles.
WFS-018	The robot should have one main microcontroller for movement and navigation.
WFS-019	The robot will be able to traverse various terrains.
WFS-020	The robot will be able to travel at a 3.1 mph.
WFS-021	The dimensions of the robot should be at most 2x2x2 ft.
WFS-022	The sensors will be able to detect obstacles at a minimum of 1ft.

2.3.3 Power

The power subsystem for the Wi-Fi Seeker will be based off of batteries. Lithium polymer batteries will be used to power the individual components of the robot, such as the microcontroller, sensors, motor controller, and wireless communication modules. In order to recharge the batteries, a solar panel will be attached to the robot. The power generated from the solar panel will enter a maximum power point tracking charge controller, which will charge the batteries from ambient light. The maximum power point tracking ensures that the solar panel is operating at its maximum efficiency.

Table 2.3.2.B - Power Requirements

Requirement ID	Requirement Description
WFS-023	The robot will be powered by lithium polymer batteries.
WFS-024	The robot will have a solar panel mounted on top of it.
WFS-025	The lithium polymer batteries will be recharged using solar power from the solar cell.
WFS-026	The batteries will be charged using maximum power point tracking.
WFS-027	The batteries will have an average life span of 20 minutes.
WFS-028	The batteries will have a minimum life span of five minutes when the robot is at full operation.
WFS-029	The batteries will be able to fully charge within eight hours.
WFS-030	The batteries will each weigh at most one pound.
WFS-031	The solar panel will weigh at most five pounds.
WFS-032	The voltage regulators will have an efficiency of at least 85%.
WFS-033	The charging controller will have overcharging protection.

3.0 Research

3.1 Existing Similar Projects

3.1.1 KnightroKart

KnightröKart is a University of Central Florida Senior Design project completed in the Spring semester of 2012. KnightröKart is an Android controlled vehicle race system, which utilizes an Android device as the controller for a robot that uses light sensors to stay within the boundaries of a race track. KnightröKart is controlled by an application written for an Android device, which then communicates wirelessly using Bluetooth to the robot. The robot uses its light sensors to stay within the bounds of a track that it can travel within. The robot is powered by batteries, and aside from the purchased robot body the motor components were also designed and implemented by the group.

KnightröKart has many similarities to what the Wi-Fi Seeker will have and implement. To begin with, it utilizes an Android device as a controller for the robot, and the controller communicates wirelessly with the robot via Bluetooth; the Wi-Fi Seeker robot will also be controlled by an Android device that communicates with the robot via Bluetooth. KnightröKart is also equipped with light sensors to prevent the robot from moving out of a specified boundary; the Wi-Fi Seeker will also have optical sensors to assist with collision avoidance. The body for each KnightröKart was purchased, and then the motor components were replaced with H-bridges installed by the group to provide motor control for the robot; the Wi-Fi Seeker will use this same technique for the robot body and motor control. Finally, KnightröKart operated off of battery power; the Wi-Fi Seeker will also be powered by batteries. As a result of the many shared topics between KnightröKart and the Wi-Fi Seeker, the KnightröKart documentation will be a valuable resource and will serve as a reference design to assist in the development of the Wi-Fi Seeker.

3.1.2 T-100 Watch Dog

The T-100 Watch Dog is a University of Central Florida Senior Design project completed in the Summer semester of 2014. The T-100 Watch Dog is a surveillance robot that is controlled by an Android device, has multiple cameras for detecting motion, connects to a web server to allow images from the webcam to be saved, as well as an autonomous mode where the robot will track motion. The T-100 Watch Dog had many complex functionalities and thus used a very powerful system-on-chip that ran a version of Linux.

The T-100 Watch Dog shares many of the same design patterns that the Wi-Fi Seeker will also have. For one, the T-100 Watch Dog is controlled by an Android device, and through the use of Wi-Fi the video feed is streamed to the user's Android device; similarly, the Wi-Fi Seeker robot will be controlled by an Android device, and the Android application will display a video feed from a camera on the robot. As for movement, the T-100 Watch Dog's motion is controlled by four different motor controllers, one for each wheel and each equipped with H-bridges, that receives an analog signal from the microcontroller. In comparison, the Wi-Fi Seeker will also use H-bridges to control the motors, except it will only have two motors. Finally, the T-100 Watch

Dog is powered by lithium polymer batteries that can be recharged by a separate battery charger; the Wi-Fi Seeker robot will also be powered by lithium polymer batteries, except they will be recharged by solar panels. These aspects of the design of the T-100 Watch Dog are extremely similar to what will be implemented by the Wi-Fi Seeker, and therefore the T-100 Watch Dog documentation will also serve as a reference design.

3.2 Relevant Technology

3.2.1 Microcontrollers

The central component to the Wi-Fi Seeker will be the microcontroller, which will be responsible for controlling the sensor, motor, Wi-Fi communication, and possibly the video streaming subsystems. Thus one of the requirements for a microcontroller is that it must be able to communicate with multiple devices. Another important feature the microcontroller should have is low power, since the Wi-Fi Seeker is being built with the least power-consuming components as possible. The microcontroller should also be fast in regards to data communications so that the Wi-Fi Seeker is quick and responsive. There are a number of available microcontrollers that could be selected, but the search was narrowed to Atmel's Atmega328 and Texas Instrument's MSP430F5529. Some of the details regarding each microcontroller are shown in Table 3.2.1.A below.

Table 3.2.1.A - Microcontroller Comparison

Specifications	Atmega328	MSP430F5529
UART	1 port	2 ports
SPI	1 port	4 ports
I ² C	0 ports	2 ports
Power Consumption	1.8-5.5 V	1.8-3.6 V
RAM	2 KB	8 KB
Flash Memory	32 KB	128 KB
Data Bus	8-bit	16-bit
CPU Speed	20 MHz	25 MHz

Examining Table 3.2.1.A above, the first three specifications are related to communications. On Atmel's Atmega328 microcontroller, there is one programmable serial Universal Asynchronous Receiver/Transmitter (UART), one Master/Slave Serial Peripheral Interface (SPI), and no interface for Inter-Integrated Circuit (I²C) communications. However for the MSP430F5529, there are two ports that support UART communications, two other ports that support I²C communications, and then four ports that support SPI, though the four SPI ports are made of the two UART and two I²C ports. With regards to communication, the MSP430F5529 emerges the winner as it has four possible ports for communication versus the Atmega328's two. With regards to power consumption, the MSP430F5529 operates from 1.8-3.6 volts while the Atmega328 can consume up to 5.5 volts, making the MSP430F5529 more power efficient. As for the rest of the statistics, the MSP430F5529's processor is also faster than the Atmega328, it has a bigger data bus, as well as more flash memory and RAM. After considering the specifications, while the Atmega328 could be used for the Wi-Fi Seeker, the MSP430F5529 is

better equipped to handle the many challenges, and thus the MSP430F5539 was chosen to be the microcontroller that would control the many subsystems to the Wi-Fi Seeker.

3.2.2 Sensors

One of the requirements for the Wi-Fi Seeker is that it is able to maneuvering both indoor and outdoor environments. In order to successfully track Wi-Fi signals, the Wi-Fi Seeker must be able to detect obstacles and make a correction to course to avoid the object to continue its tracking mission. To accomplish this several different methods of obstacle avoidance were researched.

Tactile Sensors: The first type of technology that examined was the tactile sensor. Tactile sensors require physical contact with an object. Thus when pressure is detected the sensor will send a signal back to relay the information to the microcontroller than an object is in the way. The Minisense 100 by Measurement Specialties was the sensor chosen to study this technology. The way this sensor works is by stressing a strip of piezoelectric material. When this material is stressed it can produce a voltage spike upwards of positive ninety volts. This spike in voltage is then translated into G-force experience by the sensor. Since there is such a large voltage spike, an ample amount of resistance is needed to bring the voltage down to a safe level in order to interface with the microcontroller.

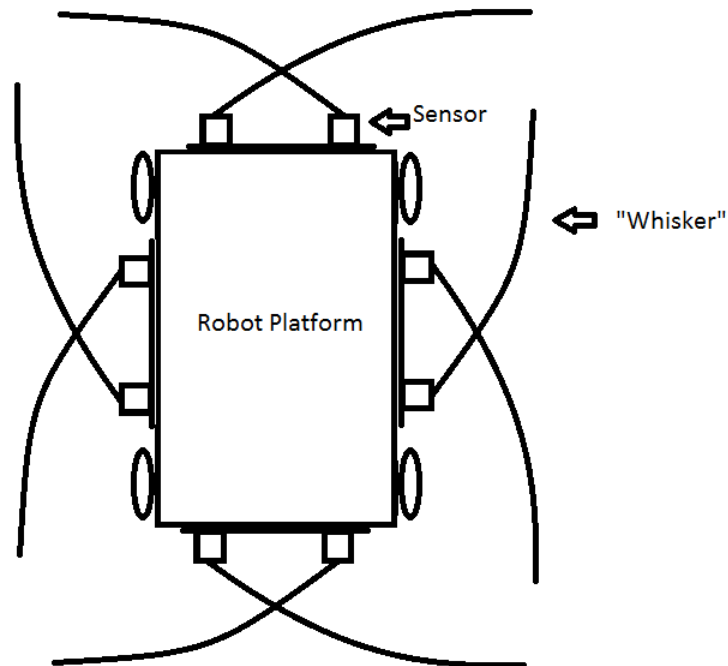

Figure 3.2.2.A - Minisense 100 Example Configuration

Figure 3.2.2.A shows how the Minisense 100 will be used with the Wi-Fi Seeker robot. The sensor will be mounted to the robot platform and the “Whiskers” attached to the sensor. Should the “Whiskers” come into contact with an obstacle, the piezoelectric material in the sensor will

be stressed as a result, notifying the MSP430F5529 that an obstacle is in the way. Using this configuration would require the robot footprint to be almost doubled in order to get the coverage needed to detect obstacles.

Non-tactile Sensors: Non-tactile sensors are sensors that do not require physical contact with an obstacle. They generally use an emitter that will emit a signal and a detector in order to detect the signal reflected by an obstacle. Since no contact is required, the Wi-Fi Seeker robot would not need to reverse in order to correct its course. One benefit that would result from using non-tactile sensors is that the time required in order to complete the Wi-Fi searching algorithm would be reduced, since the robot would not need to reverse when an obstacle is avoided. The second benefit is that battery usage would be reduced, since the Wi-Fi Seeker robot would not having to reverse in order to change its direction.

Infrared Sensors: Infrared sensors are another possible option in order to recognize motion, since they pick up changes in the infrared signature in the area they are monitoring. This type of sensor would also allow the robot to have a non-contact object detection system. The sensor works by emitting an infrared light and triangulating the position of an object, which can be seen in Figure 3.2.2.B. The intensity of the reflected light is used to determine the proximity of the object. Infrared sensors can detect object ranging from four centimeters to thirty centimeters. With its low range it could be advantages or detrimental depending on the scenario. These sensors are also not the most precise in ranging. One of the disadvantages of using infrared sensors is that direct sunlight could affect the reading on the sensor. However, an advantage of using infrared sensors is that they can be used in a noisy environment, unlike ultrasonic sensors.

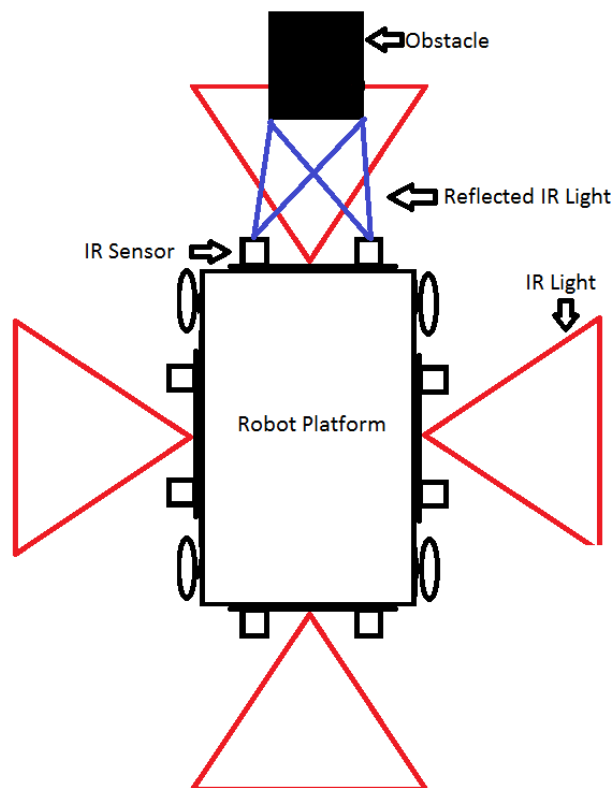

Figure 3.2.2.B - Proximity IR Sensor Configuration

Ultrasonic Sensors: Another option for a type of non-tactile sensor that could be used by the Wi-Fi Seeker robot is an ultrasonic distance sensor. The way ultrasonic sensors work is that first an ultrasonic burst is emitted, and then the sensor “listens” for the echo return pulse. Next the sensor will measure the time required for the echo to return. The return value is sent to the microcontroller as a variable-width pulse using the same I/O pin that triggered it. This sensor has an approximate range of 2 centimeter to 300 centimeters. The benefit of using ultrasonic sensors is that they would work well in brighter conditions in comparison to infrared sensors, since infrared sensors could have problems in bright light. However, ultrasonic sensors do have their own set of problems. The reading could be thrown off if the sensor encountered a sponge-like material that has the ability to absorb sound. Another issue that can occur with ultrasonic sensors is that a “ghost echo” can occur when the sound bounces off of weird or irregular objects. Overall, even with its weaknesses the ultrasonic sensor is still considered to be more accurate than other non-tactile sensors.

3.2.3 Robot Base

The robot base is constituted by the drive train, drive motor, and motor controllers. The robot base will need to travel at reasonable speed while carrying all of the sensors, battery, electronics, and solar panels that are attached to the robot. As such there are several considerations that will be taken into account when choosing a robot platform for the Wi-Fi Seeker robot project. Size Weight

Platform: The size of the platform is the most important factor to consider. The platform for the Wi-Fi Seeker robot needs to be large enough in order to carry all of the electrical components, as well as the cumbersome solar panel. One on hand, if the platform is too large, it will not be able to fit through door openings, hallways, or other indoor obstacles, which would then limit the robot’s ability to survey locations in order to measure the Wi-Fi signal strength. The Wi-Fi Seeker robot also cannot be too large because the operator needs to be able to easily transport the robot to the location it will be used at, i.e. the user should be able to pick up and carry the robot. Preferably the robot should fit into a mid-size sedan. On the other hand, if the size of the robot is too small it will not be able to carry all of the components that need to be mounted. The robot has to be large enough to mount a solar panel securely on a flat surface and carry enough batteries to last long enough to complete its mission.

The next factor that will be considered is weight. Not only should the weight of the robot body be low, but also the weight of the robot with all of its components mounted needs to be taken into consideration. Therefore the body for the robot must be chosen carefully, as well as the motor and batteries, in order for to be able to maintain a certain weight such that the Wi-Fi Seeker robot can move at a respectable speed. This means that the robot body should be as light as possible in order to maximize the speed that the robot can travel at. The tradeoff, however, will be stability, as the lighter the robot body the less stable it will be when traveling to complete its mission.

The final factor that will be considered is whether the Wi-Fi Seeker robot should wheels or caterpillar treads. For the application of the Wi-Fi Seeker robot, the various terrains it will be required to be able to travel across include the likes of concrete, asphalt, tiled flooring, wood

flooring, carpet, and potentially others. The caterpillar track has many advantages and can travel across a variety of surfaces. It is able to handle uneven, soft, hard, and rough surfaces. Caterpillar track also has greater traction compared to wheels since it has more contact with the surface and therefore can distribute weight more evenly across the surface it is in contact with. However the disadvantage of using caterpillar track is that it cuts down on the vehicle's top speed and puts more strain on the motor. As a result this will shorten the life span of the motors. Another challenge would be that using caterpillar track is much more complex than using wheels. Assembling and installing the track is a labor intensive and complex procedure. Finally, caterpillar track is more expensive than the cost of wheels. Taking all of these factors into consideration, wheels were chosen to be fitted to the Wi-Fi Seeker robot. This is because the wheels are less expensive, which will keep costs down, as well as the fact that the wheels are much more simple to implement and use, and that they are more flexible than caterpillar track.

3.2.4 Motors

Since it has already been decided that the Wi-Fi Seeker robot will be using DC motors, the next decision is to decide between using brushed or brushless motors. These two types of motors operate similarly by having the motor winding energized and having a temporary magnetic field created to repel against the permanent magnets. The force is then converted into shaft rotation. As the shaft rotates, electric current is routed to different winding that maintain electromotive repulsion/attraction. Motors are one of the most important components when it comes to mobility and power consumption. Without choosing the proper type of motor, the robot will not be able to efficiently use the power supplied to it.

Brushed Motors: Brushed motors are simpler in design since they only require two wires with a potential difference in voltage of operate. The brushes inside the motor are used to deliver current to the motor winding through commutator contact. The windings are on the rotor, i.e. the rotating part of the motor. The advantage of using brushed motors is that they are simple and inexpensive. The disadvantages are that brushless motors are less energy efficient, are electrically noisy, and have a shorter lifespan. The only way to combat the shortened lifespan of the motor is to replace the brushes, which will then increase the lifespan.

Brushless Motors: Brushless motors use hall position sensors in order to determine the position of the rotor. They switch the field by using an amplifier triggered by a commutating device, such as an optical encoder. The windings are found on the stator, i.e. the stationary part of the motor. By having the winding on the outside of the stator the need for brushes is eliminated. The advantages of using brushless motors are that they have a longer lifespan, are low maintenance, and are highly efficient. The only disadvantage is the higher cost because using a brushless motor creates a for a driver or controller.

Servos: A servo is a device that contains a DC motor, a potentiometer, and reduction gears. They work by having the position of the shaft, measured by the potentiometer, continually compared to the commanded position from the controller. When an error signal is detected the electric motor moves in the appropriate direction, forwards or backwards moving to the commanded position. When the servo is in the correct position the error signal becomes zero and the servo stops moving. Servos are connected through a three-wire connection. Two wires are needed for

the DC power supply, and one wire is needed for control carrying a PWM (pulse-width modulation) signal.

3.2.5 Motor Controllers

The motor controller is an essential component in controlling and making the Wi-Fi Seeker robot mobile. The motor controller will tell the DC motors which direction to go, how fast to travel in that direction, and will control the speed of rotation of the wheels. The motor controller will also provide the option to turn off the motors completely. Since the Wi-Fi Seeker robot have a wide range of mobility, four motors will be used. This raises the question as to a four port motor controller or four separate motor controllers should be used to control the four motors. Implementing one of these configurations will allow the Wi-Fi Seeker robot to move in any direction without having to turn the wheels.

Biasing the motors is the simplest way to control a DC motor. By forward or reverse biasing the motor the user can control whether the motor will turn clockwise or counter-clockwise. An H-bridge relay is an inexpensive and effective method to perform this function. This device uses a transistor as an electrical switch in order to control the current flow. Paths are opened and closed by biasing certain transistor pairs. Using an H-bridge relay will allow the robot to move forwards and backwards, but with no way to control the speed of the motors. In order to control the speed of the motors, an oscillating circuit can be used to vary the duty cycle. This circuit will control how long the motor is on and off, which in turn controls the speed. This is known as PWM (pulse-width modulation). Many microcontroller have the ability to create PWM signals but not many can produce four separate signals. There are three options: use a microcontroller that can produce four separate signals; create four separate PWM circuits that are controlled by the microcontroller with an analog signal; or create four separate PWN circuits that are controlled by an H-bridge relay with a shared PWM signal. The advantage of the second option would be greater control over each motor and allow us to use most DC motor. The advantage of the last option would be control of all motor with one PWM signal, but a disadvantage is that the ability to control each motor individually is limited. One of the most popular methods of creating a PWM signal is to use the LM555 timer. This device is highly stable and can create accurate time delays and oscillation.

Talon SRX: The first motor controller to be analyzed is the Talon SRX. This is a robust motor controller capable of operating with voltages up to 28 V and 60 A continuously. It has four different types of input methods. The first is the standard RC interface, using PWM. The second is a Controller Area Network interface (CAN), which is a protocol that allows a microcontroller to communicate with multiple devices through a CAN bus. The third method is Serial Peripheral Interface (SPI) that is used for short distance, single master communication. The final method is Universal Synchronous/Asynchronous Receiver/Transmitter (USART) serial. It has many other features but these are not needed since they will only further complicate the coding of the robot.

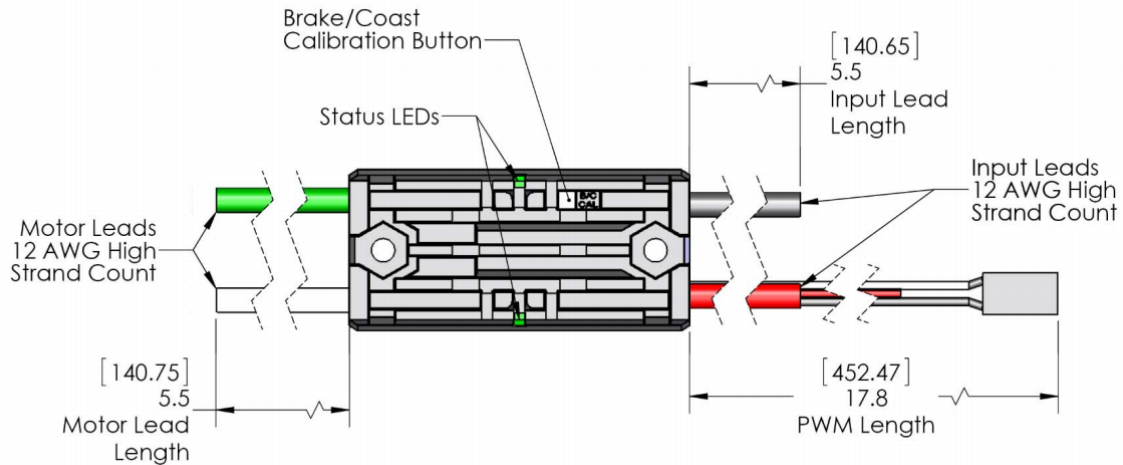

Figure 3.2.5.A - Talon SRX Motor Controller

Designing a Motor Controller: Another option is to design the motor controllers and build them from components. There are a vast amount of resources available that would to help with the design and building process. This method also allows the Wi-Fi Seeker robot to get all of the features it needs.

H-Bridge Chip: H-Bridges are integrated circuit chips that have all the components of an H-bridge put together in one convenient package. This can save a lot of time since the H-bridge does not need to be built from scratch and have the accompanying issue of having to deal with the offset voltages. These chips also come in packages of multiple H-bridge build into one device to save on space and cost. The H-bridge circuit is connected directly to the motor of the robot. An H-bridge is made usually made up of four transistors. A simple diagram is shown in Figure 3.2.5.B. In Table 3.2.5.A, note that the H-bridge uses the following sequence: 0 = open and 1 = closed.

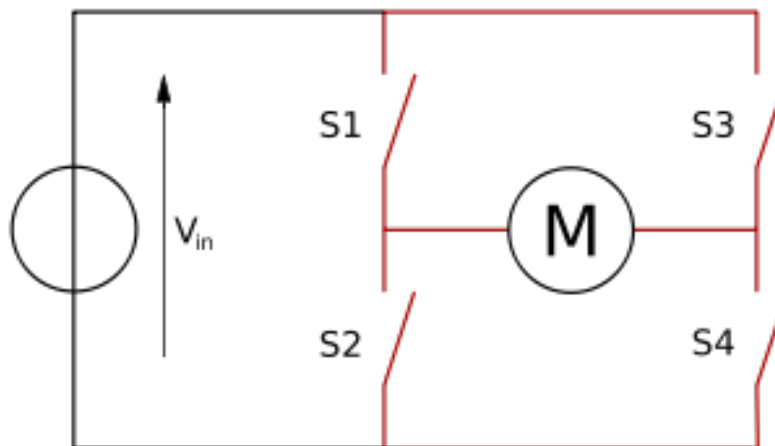

Figure 3.2.5.B - Shows basic structure of an H-bridge

Table 3.2.5.A - H-Bridge sequence

S1	S2	S3	S4	Result
1	0	0	1	Motor moves right
0	1	1	0	Motor moves left
0	0	0	0	Motor free runs
0	1	0	1	Motor brakes
1	0	1	0	Motor brakes
1	1	0	0	Shoot-through
0	0	1	1	Shoot-through
1	1	1	1	Shoot-through

Bi-polar Junction Transistor (BJT): In order to build an H-bridge, one option is to use a BJT. BJTs are simple circuits that are easy to use, but they consume more power than FETs. They also have slower switching times and have a voltage drop of 0.7 V (assuming silicon). This means when using a basic H-bridge there will be a 1.4 V drop over the transistor.

Field Effect Transistors (FET): The other option is to use a FET in order to build the H-bridge. These transistors have a faster switching time and consume less power than BJTs, however the design for FETs is a bit more complicated and expensive.

3.2.6 Remote Control System

Once the requirements and specifications for the Wi-Fi Seeker had been determined, the next step was to determine what kind of controller would be used. The controller would have to be able to communicate with the robot via a wireless communication protocol, as well as be able to display a video stream sent from the robot. This led to the conclusion that a smart device should be chosen as the controller, such as a smartphone or a tablet. The next choice was to choose between the top two competitors in the smart device market - either a device running Google's Android operating system or a device running Apple's iOS operating system.

There were several factors that were considered when deciding which platform would be chosen to develop the device controller application for. The first factor was support: Google's Android has extensive tutorials and documentation for all of the libraries and APIs it has released. Apple's iOS has its own Developer Library, which also has APIs as well as tutorials and sample code. Both operating systems have forums for discussing issues and asking questions about how to implement specific functionality. As a result of the two platforms being equivalently well documented, a decision could not be made by simply looking at the factor of support.

The second was cost. In order to become a developer for Google's Android, a developer must register for a "Publisher Account" with Google. There is a one-time \$25.00 fee that accompanies registration, but then the account is allowed to publish applications to the Google Play store. There is no limit to the number of applications that the account is allowed to publish, and after paying the initial fee publishing is free. In order to become a developer for Apple's iOS, a developer must enroll in the "iOS Developer Program". This is a subscription service that charges \$99.00 once a year. The subscription includes tons of sample code, testing environments, access to the exclusive Apple Developer Forums, and of course the ability to publish applications

to the Apple App Store. With the intention of keeping this project as low-budget as possible, on the factor of cost Google's Android operating system was decidedly more appealing.

The final and most important factor considered was language. Applications for Google's Android devices are developed using Java and XML, while Apple's iOS applications are developed using Objective-C programming. Developing an application on either of these platforms would require not only the back-end coding for functionality but front-end coding for the graphical control and the user interface. Since the use of Java and XML is functionally comparable to using Objective-C, this factor was decided by examining group member experience. Of the three members, two are electrical engineers who only know the C language, which is not the same as Objective-C that iOS development utilizes. The third group member, however, is a computer engineer who has extensive experience in Java and has previously developed Android applications. Considering the complexity of the task at hand, it was decided that choosing the Android operating system would be a smart decision because of the group's previous experience as well as the reduced cost that comes with developing for Android.

Simply deciding to use the Android operating system is not enough; a specific version of Android must be chosen to develop the application in. Google releases a new version of their Android operating system about once a year. These larger releases usually include a number of new features and libraries to accompany them. When choosing exactly which version of the operating system to use, it was decided that the two most important factors were to choose a popular operating system that a lot of Android users were using, and to choose a recent version of Android such that the most up-to-date APIs would be accessible by the developed application. As shown in Figure 3.2.6.A, the percentage of the current market using the Jelly Bean operating system is 50.9% by itself, and the next generation KitKat makes up another 30.2%. Considering that the newest operating system KitKat is already holding over quarter of the market, and that the number of Android users running KitKat will only increase with time, it was decided to develop the Android application using version 4.4, i.e. KitKat. Since Android promotes backwards compatibility, we are confident that our application will work for any Android device, including all devices currently running Jelly Bean.

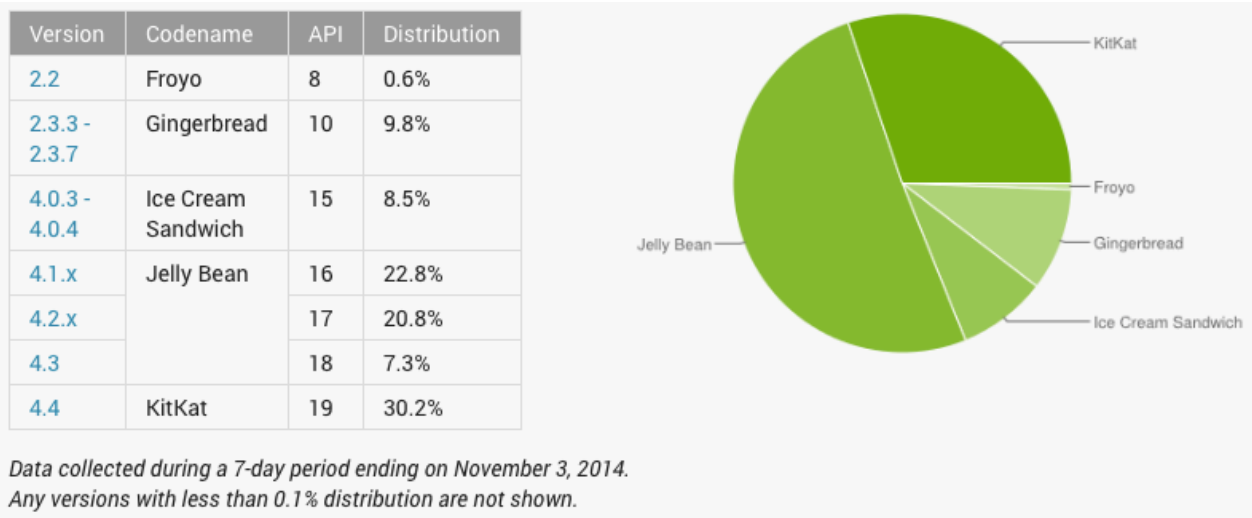

Figure 3.2.6.A - Android Operating System Usage

3.2.7 Wireless Data Communication

Once it was decided to build a Wi-Fi Seeking robot, a major design choice had to be made regarding the type of wireless communication that would allow communication between the robot controller (i.e. Android device) and the microcontroller on the robot. The two options that were considered were Wi-Fi Direct and Bluetooth.

Wi-Fi Direct was the first option that was considered using for this project. Unlike regular 802.11 Wi-Fi, Wi-Fi Direct allows two devices to communicate without a wireless access point. One of the benefits of using Wi-Fi Direct is the 200-meter range for communication. Wi-Fi Direct also has a high data transfer rate of up to 250 Mbps. These two statistics would mean that the Wi-Fi Seeker robot would be able to be controlled from far distances, and the robot would be quick to respond to the user's commands. Additionally, Wi-Fi Protected Access 2 (or WPA2) is used to protect Wi-Fi Direct connections, ensuring that there is security for our data transmissions.

The way that Wi-Fi Direct works is that one device needs to be Wi-Fi Direct certified, which means that the device is certified by Wi-Fi Alliance. This "host" device can then allow discovery to happen the same way it does with regular Wi-Fi. In the case of the Wi-Fi Seeker robot, an IP-based network would be created between the Android device and a Wi-Fi module that would be connected to the MSP430F5529 microcontroller. After the connection is made, the Android device and the MSP430F5529 would be able to transmit data back and forth wirelessly without having to rely upon a local access point. With Wi-Fi Direct there is the option to have several different devices connected simultaneously to the same network, but for the purposes of the Wi-Fi Seeker robot a one-to-one connection would be enforced. This is because there should only be a single Android device that has the capability to control the Wi-Fi Seeker robot at any given time. Additionally, by only allowing a one-to-one connection to take place the issue of interference with other Wi-Fi devices will be prevented, since other wireless devices will not be allowed to connect to the network that exists between the Android device and the Wi-Fi module.

The second mode of transmission considered was Bluetooth. It is a type of peer-to-peer wireless transmission that operates in the range of 2.4 GHz to 2.4835 GHz, a frequency band that is reserved for ISM (Industrial, Science, and Medical) devices. For versions Bluetooth 2.0 and later, the top data transfer speed is 3.0 Mbps. In order to connect and transmit data between two Bluetooth devices, a connection must first be made between the devices. When it comes to the range of a Bluetooth transmission, it depends on which class the device is in. The operating range of Bluetooth is defined by classes that are organized by power consumption. There is a direct correlation between power consumption and transmission range of Bluetooth devices: Class 1 Bluetooth devices operate at about 100 mW and have a range of up to 100 meters; Class 2 Bluetooth devices operate at about 2.5 mW and have a transmission range of up to 10 meters; Class 3 Bluetooth devices that operate at about 1 mW and have a transmission range of up to 1 meter. Since the Wi-Fi Seeker is to be an autonomous robot that communicates with an Android device, a Class 1 Bluetooth module was decided upon. This is because a range of 1 or 10 meters would be an unacceptable range for the maximum distance between the device controller and the robot, but the 100 meter range offered by Class 1 Bluetooth devices would provide a sufficient maximum distance.

Another factor to consider with Bluetooth is its low power consumption. Bluetooth EDR (Enhanced Data Rate) was introduced with Bluetooth 2.0, the minimum version the robot would use, which utilizes different modulation techniques to bring the transfer speed up to 3.0 Mbps, but more importantly it cuts down the amount of power used by reducing the duty cycle. This means that the amount of time that the transmitting signal is active is reduced during a period of transmission. This reduction results in a decrease in power consumption when using Bluetooth. This is highly advantageous because the robot will already be equipped with a low-power microcontroller, and to keep power consumption at a minimum low-power components need to be chosen. Therefore Bluetooth would be a good choice for wireless communication because of its low power consumption.

The decision of choosing the type of wireless data communication came down to three data points: speed, transmission range, and power consumption. When choosing which communication medium to use, the first data point that was considered was data transfer rate. Bluetooth 2.0 caps out at a speed of 3.0 Mbps. While this is significantly slower than the maximum transmission rate of 250 Mbps for Wi-Fi Direct, this was not considered a deal-breaker in terms of the Wi-Fi Seeker project. Since the only communication that will be taking place between the Android device and the robot will be either simple commands or a piece of data indicating the current Wi-Fi signal strength, the 3.0 Mbps should be enough to get the job done. The video streaming will be discussed later, but the video stream will not be sent over Bluetooth. Thus because of the distinct advantage that Wi-Fi Direct has over Bluetooth when it comes to the speed of transferring data, this data point favored using Wi-Fi over Bluetooth, but Bluetooth has not yet been ruled out as an option.

The second data point that was considered when choosing a means of wireless communication was range of transmission. On one hand, choosing a Class 1 Bluetooth device would mean that the Wi-Fi Seeker robot would have at most a 100 meter range for communicating. On the other hand, Wi-Fi Direct has twice the range that a Class 1 Bluetooth device has, specifically 200 meters in comparison to 100 meters. While anticipating the user to stay within 10 or less meters of the Wi-Fi Seeker robot is not a realistic expectation, anticipating the user to stay within 100 or less meters of the robot is a realistic expectation. To put this into perspective, consider the length of a football field, which is 110 meters. The whole point of the Wi-Fi Seeker robot is to sniff out the location of the strongest Wi-Fi signal, with the implied result being that the user will then go to the determined location in order to receive the best reception while connected to the specified wireless network. If a user is a football field's length away, s/he would not be properly using the Wi-Fi Seeker robot, because s/he would not be able to reap the benefits that the findings of the robot provides. Therefore the decision for choosing the wireless communication could not be made based off of transmission range, because in practice the range of Bluetooth should be more than enough for the Wi-Fi Seeker's specific application.

The third and final data point that was considered when choosing between Bluetooth and Wi-Fi Direct for wireless communication was power consumption. As previously discussed, Bluetooth operates using very little power. Historically Wi-Fi requires much more power, and thus Wi-Fi Direct does as well, though with the latest advancements Wi-Fi Direct has claimed to be up to 40 percent more power efficient in battery powered devices. In truth, there are not hard numbers that describe how much power is used when transmitting data using Wi-Fi Direct, and

considering that Wi-Fi requires a lot of power in order to work and that Wi-Fi Direct is an adaption of the classic Wi-Fi, it is safe to assume that Wi-Fi Direct is at best comparable to the power consumption of Bluetooth. Yet because of the lack of specific numbers, this data point leans towards Bluetooth being a more optimal choice over Wi-Fi Direct. When tallying all three data points, Wi-Fi Direct is both faster at transmitting data and can transfer data from a further range, and Bluetooth's only possible advantage over Wi-Fi Direct is that it has a guaranteed lower power consumption. However, when framing the data points to cater to the Wi-Fi Seeker robot, the transmission range of Bluetooth is acceptable, the guaranteed low power consumption is desirable, and the lower transmission speed is enough to get the job done for the purposes of the Wi-Fi Seeker. Additionally, there is the fact that even though Wi-Fi Direct has been around for several years there is a lack of popularity and support for this method of wireless communication. Bluetooth still dominates when it comes to peer-to-peer transfer of data, and there are many more reference designs that use Bluetooth over Wi-Fi Direct. Therefore after careful examination of Bluetooth and Wi-Fi Direct it was decided that the means of communication between the Android device and the robot will be through Bluetooth.

3.2.8 Wi-Fi Signal Sensing

The Wi-Fi Seeker's main purpose is to determine the location of the strongest Wi-Fi signal in an area, thus the robot needs to have a way to determine the strength of a Wi-Fi signal. Seemingly the only method to do this is by measuring the Received Signal Strength Indication (RSSI). In order to determine the RSSI of a wireless signal, the power from the signal must be measured. Deciphering the results from measuring the RSSI of a signal depends on the type of wireless networking card that is being used to receive the signal. Each card has its own specifications for how RSSI measurements are to be read. Thus in relation to the Wi-Fi Seeker, understanding the RSSI metric will not be possible until a specific wireless module is chosen for the robot.

RSSI was defined with the IEEE 802.11 standard. In the protocol it is specified that there is a direct relationship between the strength of a Wi-Fi signal and its RSSI signal, such that the stronger that the wireless signal is, the higher the RSSI measurement value will be. According to the standard, there is no specified conversion between the amount of milliwatts (mW) or decibels (dB) that specify a wireless signal's power level and the corresponding RSSI value. This is another metric that is left to be decided by the manufacturers of the individual proprietary wireless networking cards. As a result, the various wireless networking cards each have different power levels associated with different RSSI values. This is a data point that will be considered when choosing a wireless module for the Wi-Fi Seeker, in order to keep the robot as low-power as possible.

In application to the Wi-Fi Seeker, the measuring of the RSSI is going to be the key to the algorithm guiding the robot. After installing a wireless module on the robot, the module will be used to poll for the Wi-Fi signal's RSSI value as the robot continues to move around in an area. If the robot travels in one direction and sees a pattern of the RSSI value decreasing, the robot will know to change its course. Along this same line of thought, if the robot travels in another direction and sees a pattern of the RSSI value increasing, the robot will know to continue along its course. Theoretically at some point the robot will either receive a RSSI value of the maximum possible value, or it will reach a scenario where regardless of which direction it moves in, the

RSSI value of the wireless signal decreases. This will be the stopping condition for when the robot has found the best wireless signal in an area. This is the preliminary and basic design for the algorithm that the Wi-Fi Seeker robot will use to seek out a strong Wi-Fi signal.

3.2.9 Video Streaming

One of the requirements for the Wi-Fi Seeker is to have a video stream that allows the user to see what the robot is doing and where it is going when it enters its autonomous mode. To do this, a camera will be mounted on the robot and the video stream will be relayed to the Android device via Wi-Fi. There are two methods for displaying a video; the first is to take several pictures very quickly and display them in rapid succession, in a stop-motion format. The second method is to actually stream the video being recorded by the camera.

The benefit of the first option, taking and sending pictures, is that overall less data has to be sent. Since sending a video requires many more frames than displaying still frames semi-rapidly, it would cost less power and less data to implement the stop-motion method of displaying what the robot sees on the Android device. However, sending and displaying still images is costly on the side of effort. First, a camera must be connected to the microcontroller. Then, the microcontroller has to constantly tell the camera to take pictures, and for each image the data has to be compressed and sent to the Android device via Wi-Fi. After the Android device receives each image, the image must be displayed for a short period of time. The major issue with this method is the amount of effort it would take to develop the algorithm for displaying still images rapidly enough. In addition, the MSP430F5529 has been chosen to be the microcontroller, but it is not the optimal microcontroller for handling the sending of large amounts of data that using a camera module would require.

The second option is to stream the video directly to the Android device. As aforementioned, the MSP430F5529 is not well equipped to handle large amounts of data flow that accompanies sending images. In addition, a standard USB webcam cannot be hooked up to the MSP430F5529 since it is not a system-on-chip architecture. Therefore, in order to be able to stream a video to the Android device, the microcontroller will be bypassed and the camera will communicate directly with the Android device. This involves using an Internet Protocol (IP) camera, which has its own hardware for connecting to a wireless signal. This would circumnavigate the limitations of the MSP430F5529's rate of communication while allowing the Wi-Fi Seeker to remain as low power as possible. After the IP camera is initially configured with a static IP address, the Android device will be able to directly connect to it and display the video stream being sent by the camera.

3.2.10 IP Cameras

The Wi-Fi Seeker will be equipped with an IP camera so that a video stream displaying what the robot "sees" can be sent to the Android device enabling the user to view the stream. There are many brands and variations of IP cameras on the market, and they can get quite expensive. Two different cameras were examined as potential candidates for the Wi-Fi Seeker: the Foscam FI8910W Wireless IP Camera and the D-Link DCS-932L Wireless Day/Night Camera. In Table 3.2.10.A below several different specifications are compared between the two cameras.

Table 3.2.10.A - Comparison of IP Cameras

Specification	Foscam FI8910W	D-Link DCS-932L
Dimensions (L x W x H)	8.0 x 5.0 x 6.5 inches	2.6 x 2.6 x 5.0 inches
Wireless Standard	IEEE 802.11 b/g/n	IEEE 802.11 b/g/n
Wireless Security	WEP/WPA/WPA2	WEP/WPA/WPA2
Display Resolution	640 x 480 pixels	640 x 480 pixels, up to 20 fps 320 x 240 pixels, up to 30 fps
Power Consumption	5V at 2A	5V at 1.2A
Operation Temperature	14°F-122°F	32°F - 140°F
Image Compression	MJPEG	MJPEG
Supports HTTP	yes	yes
Supports UDP	yes	yes
Price	\$55.00	\$60.00

When it comes to the wireless specifications, the IP cameras are comparable. The Foscam FI8910W and D-Link DCS-932L support the same wireless standards and wireless security protocols. As for the actual video streaming protocol, both cameras support the two main protocols that the Wi-Fi Seeker might implement, HTTP and UDP. The resulting video from both cameras is in the format MJPEG as well. As for display resolution, both cameras support 640 x 480 pixels, but the D-Link DCS-932L also supports a lower resolution of 320 x 240 pixels at a faster rate of 30 frames per second. This makes the D-Link camera more well-rounded, for in the event that the Wi-Fi Seeker has a weak connection to the Internet the D-Link camera would be able to continue to send the video stream at a lower resolution whereas the Foscam camera might lag or pause the stream. In regards to physical dimensions, the D-Link DCS-932L is considerably smaller than the Foscam FI8910W. This would make the D-Link camera easier to fit into the Wi-Fi Seeker if the robot body were to get crowded by the other parts. When it comes to power consumption, the D-Link DCS-932L requires 0.8 amps less current than the Foscam FI8910W, which is desirable since the Wi-Fi Seeker robot is aiming to consume as little power as possible in an attempt to be energy conscious. Finally, the Foscam FI8910W camera and the D-Link DCS-932L both have an operating temperature range of 108°F, the only difference is that the FI8910W can operate at slightly cooler temperatures and the DCS-932L can operate at slightly warmer temperatures. After considering all of these specifications, the D-Link DCS-932L was chosen to be the IP camera that would be fitted into the Wi-Fi Seeker. Overall it is smaller, operates using less power, and supports different video resolutions, which will make it more robust and more likely to be able to continuously stream to the Android device.

3.2.11 Potential Power Sources

Every electronic devices needs to be powered by an external source. In the case of the Wi-Fi Seeker robot, the source of power needs to be portable and renewable. The types of renewable energies that were viable were taken into consideration One type of renewable energy is wind power through a turbine. Another type of renewable energy is solar. Since both of these energy sources have their advantages and disadvantages, both will be examined in order to determine which will be the better fit for the Wi-Fi Seeker robot.

Wind Power: One advantage of wind power is that it is free and clean, so it does not contribute any pollution to the environment. Another advantage of implementing a wind power solution is that wind turbines are relatively cheaper in comparison to solar panels. One disadvantage is that wind turbines usually produce a lot of noise, which can be irritating to others, and depending on which components are attached to the robot, could cause interference. Another disadvantage of wind power are that wind might not be blowing consistently. Therefore, there will be times where almost no electricity is generated. Additionally, a wind turbine implementation would add a lot of weight to the Wi-Fi Seeker robot. The robot needs to be as lightweight as possible in order to be more energy efficient.

Solar Power: Some of the advantages of solar power are that it is abundant, free, and environmentally friendly, similarly to wind power. Another advantage is that solar panels are fairly lightweight, so the robot can be more energy efficient as it moves about an area. Additionally, because of the abundance of solar panels, there are many in existence and they come in all shapes and sizes. This will make it easier to find a solar panel that will be able to fit onto our robot and provide enough energy to charge the batteries.

One disadvantage of solar power is that solar panels can be very expensive. Another disadvantage is that they require a lot of space, since the more area a solar panel covers the more resulting energy can be collected and redirected. Mounting a solar panel on the Wi-Fi Seeker robot will require that the robot is large enough to be able to sustain the size of the panel. Lastly, solar energy is not always available. During the middle of the afternoon on a cloudless day when the sun is shining brightly is when solar panels are able to generate the most energy. However, during nighttime, or on cloudy days, little to no electricity would be produced and no charge would be collected during these times.

After analyzing all of the advantages and disadvantages of both wind and solar energy, using solar panels on the Wi-Fi Seeker robot seems to be the more viable option. Since solar panels are lightweight, the robot will be able to be more energy efficient as it is not as weighed down as it would be using a wind turbine. In addition, the energy from the sun is more reliable than wind energy, and certain types of solar cells are able to absorb artificial light, making it a viable indoor solution as well. Finally, the ability to choose from the many different shapes and sizes based on the robot body allows for more breathing room when choosing the body of the robot and how all of the components are going to fit onto the robot.

3.2.12 Types of Rechargeable Batteries

Since the Wi-Fi Seeker robot is going to be equipped with solar panels as renewable energy source, there needs to be a way to store this energy when the robot is not in use. Rechargeable batteries offer a great storage solution. Batteries are simply a storage element that converts chemical energy to electrical energy and vice versa. There are many different types of batteries depending on the cell chemistry associated with them. Along with each of the various types of batteries are benefits and downsides that are associated with the type. Therefore, in order to select the best battery for the Wi-Fi Seeker robot, several batteries will be examined with respect to this specific application. The most common rechargeable batteries used today, and the ones

that will be researched, are nickel cadmium, nickel-metal hydride, lead acid, lithium polymer, and lithium ion polymer.

Nickel Cadmium: Nickel cadmium batteries have a long cycle life and high discharge rate, which is good for products such as radios, medical equipment, and power tools. They are also fairly inexpensive, and this type of battery holds up really well in harsh working conditions. As for the disadvantages, nickel cadmium batteries have a low energy density. Another major downside to these batteries is that they are made using toxic materials, which can pollute the environment. Leaving these batteries on the chargers for long periods of time can cause it to deteriorate. It can also deteriorate if the battery is not fully discharged when used, which is called the memory effect. This happens when large crystals form on the cell plates and causes the battery to lose efficiency. These batteries also suffer from a high self-discharge rate, so if they are stored for long periods of time, they will need to be recharged.

Nickel-Metal Hydride: Nickel-metal hydride batteries have up to 40 percent higher charge density than nickel cadmium, but they also have a lower cycle life. These batteries are great for cell phones, laptops, and satellite applications. These batteries contain no toxic materials, which makes them more environmentally friendly. The downsides of this battery are that they have a higher self-discharge rate than nickel cadmium batteries. Additionally, they are less durable than nickel cadmium and deteriorate under heavy use and high temperatures. The memory effect usually does not occur with these batteries.

Lead Acid: Lead acid batteries were the first rechargeable batteries available for commercial use. They are inexpensive and easy to manufacture. They are mainly used in large power applications such as hospital equipment, automobiles, emergency lighting, and UPS (Uninterruptible Power Supply) systems. The memory effect does not occur in these batteries. This battery has the best charge retention out of all the other rechargeable batteries. The downsides are that it takes a long time to charge, ranging from 8 to 16 hours. The battery has to always be charged, or else sulfation occurs, which is a condition that makes the battery difficult to recharge. These batteries don't like to be fully discharged or else the charge capacity will be reduced. This battery has a low cycle life and deteriorates as temperature increases. This battery has the lowest energy density out of all the rechargeable batteries. The battery is environmentally unfriendly because of its high lead content.

Lithium Ion: Early lithium metal based batteries were very high in energy density due it lithium being the lightest metal and having a high electrochemical potential. Lithium metal-based batteries were phased out because of safety concerns. Lithium ions were used instead and had the similar energy density characteristics of lithium metal-based batteries. Lithium ion batteries have energy densities usually two to three times as much as nickel cadmium. The high cell voltage of these batteries enables battery packs to contain only a single cell, which simplifies the design. Single cell batteries are great for cell phones and other small-scale applications. Lithium ion batteries do not suffer from the memory effect and have a low self-discharge rate. The drawbacks of lithium ion batteries are that they are fragile and pose many safety concerns since lithium is very reactive and flammable. If mistreated, they can catch on fire and explode. Most lithium ion batteries include protective circuitry to prevent from overheating and overcharging. They also have vents to release pressure that may build up.

Lithium Ion Polymer: Lithium ion polymer or li-poly batteries are similar to lithium ion batteries. They come in many shapes and sizes and are lightweight. They can be very thin, comparable to a credit card. They also can be flexible for special applications in which the battery has to be curved. Li-poly batteries offer high current discharge rates, which is great for high current applications. The downsides of li-poly batteries are that they usually have a lower energy density compared to lithium ion. They also have a lower charge cycle count. Additionally, they are more expensive to manufacture.

The Wi-Fi Seeker robot most accurately matches the needs and characteristics of either lithium ion or lithium polymer batteries. These two types of batteries are ideal because they are lightweight, which is advantageous for the robot because the less weight means that less energy is required to make the robot move. In addition, they have high energy capacities, so the robot can operate for longer periods of time. Since they are available in many different shapes and sizes, deciding where and how to place them onto the robot reduces the difficulty. Li-poly would be a great option if the motors require a lot of current to function. The rest of the non-lithium ion batteries are not a great choice because they suffer from the memory effect, and having dead batteries would render the Wi-Fi Seeker robot useless. Also, they are toxic and would not be as safe to handle. Another reason that lithium ion batteries are better is because the other types of batteries suffer from high self-discharge rates, which means a lot of energy would be wasted.

3.2.13 Other Battery Considerations

Capacity: The capacity of a battery is a measure of how much charge it can store. The capacity determines how the maximum amount of energy that can be used from the battery as long as the battery is in ideal conditions. The capacity of a battery can decrease from its nominal capacity depending on its age, temperature, and charging cycles. Capacity is the total amp-hours available when the battery is discharged at a certain current from when the battery is full until it is dead. Capacity is calculated by multiplying the discharge current in amps by the discharge time in hours. The unit for a battery's capacity is typically mAh, which means milli-amperes per hour. For example, a battery that has a capacity of 2000 mAh can output a current of 2A for 1 hour or 2mA for 1000 hours. This capacity is an important parameter because it defines how long the Wi-Fi Seeker robot can be operational for. Ideally the robot will be able to have a long life span, therefore a battery with a high capacity will be chosen.

Discharge Rate: The discharge rate is the rate at which current is drawn from the battery. The discharge rate is known as the C rate. Batteries usually have a C rate specification on them. If a battery has a C rate of 10C, it means the battery can have a discharge current of 10 times the capacity. The higher the C rate, the lower capacity will be. It is suggested by manufacturers to stay on or below the C rate to preserve the battery's lifetime. The maximum output current can be calculated once the capacity and C rate of a battery is known. To calculate the maximum output current, simply multiply the capacity by the discharge rate. For example, if a battery has a C rate of 20C and a capacity of 2000 mAh, the battery can discharge 40 Amps of current. However, since the battery is discharged higher than 1C, the capacity greatly decreases. The amount of running time can be calculated by dividing the capacity by the discharge current. Therefore, the same 2000 mAh battery discharged at 20 amps would have a running time of 0.05 hours, or 3 minutes.

This parameter is important because some of our subsystems require a high amount of current, such as the motors running the robot. The battery would also need to supply enough current for all of the other subsystems, such as the MSP 430F5529 microcontroller, the various sensors, the wireless and Bluetooth modules. In order for everything to function properly, the discharge rate should be taken into consideration.

Nominal Voltage: The nominal voltage of a battery is the reference voltage the battery operates at. The nominal voltage is the voltage measured at the midpoint of the batteries' charge or discharge cycle. When the battery is fully charged, the voltage is marginally higher than the nominal voltage. When the battery is depleted, the voltage is slightly lower than the nominal voltage. This can be shown in the Figure 3.2.13.A below. As the figure shows, as the charge decreases, so does the voltage. The nominal voltage can be seen in the middle (depicted by MPV.)

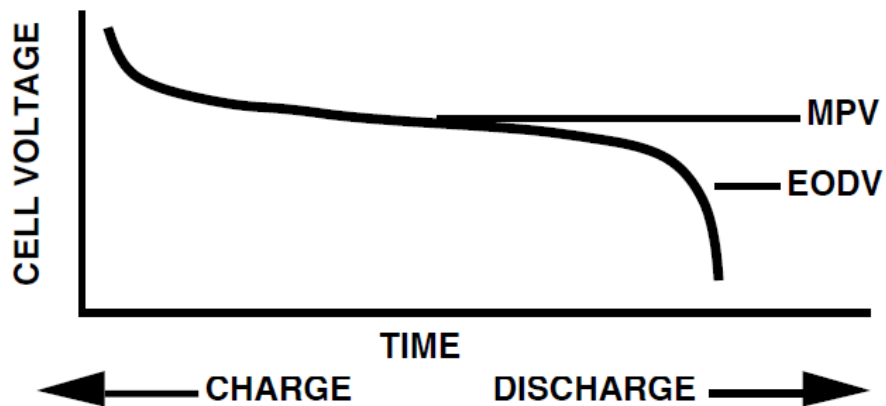

Figure 3.2.13.A - Battery Nominal Voltage

The nominal voltage is an important parameter because the parts that will make up the Wi-Fi Seeker robot will each need to be operating at a certain voltage. If a part is rated at a certain voltage, the battery needs to be about the same voltage. There would be too much fluctuation in voltage if a part were operated at the battery's maximum or minimum voltage. This fluctuation can cause the part to fail. Therefore, a part's voltage should be used with a battery that has a voltage similar to it, so that the part can function efficiently and properly.

How Many Batteries? How the subsystems will be powered is something to take into consideration. One battery can be used to power all of the subsystems but poses the risk of particular subsystems not running optimally. Another option is to have separate batteries for each subsystem. However, too many batteries would increase the weight of the vehicle, and the frame can only hold a certain amount of weight. Another possibility is to use two batteries in parallel for double the charge capacity. This would increase the running time and ensure each subsystem has enough energy for function properly.

Choosing a Battery: The first step in designing the power system would be to determine the battery that will be used. Since step down voltage regulators will most likely be used, a battery

will be needed that has a nominal voltage higher than the all of the component's voltage specifications. The motors have the highest voltage requirement at 7.2V, and therefore the battery needs to have a nominal voltage of at least 7.2V. To meet the total requirements of the system at 28A, the battery must have a very high discharge rate. Another consideration is the weight of the battery because the robot's frame can only support 20 pounds. The battery will probably be one of the heaviest components, so it must be chosen carefully. The different battery options that can be used for the Wi-Fi Seeker robot are listed in Table 3.2.13.A below.

Table 3.2.13.A - Comparison of Rechargeable Batteries

Manufacturer	Thunder Power	Hunger Lipos	Thunder Power
Model Number	TP2700-2SPP25	RC03217	TP2100-3SPP25
Price	\$39.99	\$18.45	\$34.99
Nominal Voltage	7.4 V	7.4 V	11.1 V
Capacity	2700 mAh	3000 mAh	2100 mAh
Discharge Rate (C)	25	25	25
Chemistry	Li-polymer	Li-polymer	Li-polymer
Weight	0.26875 lb	0.46875 lb	0.332898 lb
Calculated Current Output	67.5 A	75 A	52.5 A
Operating Current	28 A	28 A	28 A
Battery Life	5.78 min	6.42 min	4.50 min

In order to choose between the battery candidates, they will be compared and the one that can best meet the needs of the Wi-Fi Seeker robot will be. Both lithium-polymer and lithium-ion batteries supply enough voltage to power the robot. However, the total amount of current output has to be considered to see if it will allow the subsystems to run correctly. By calculating the total amount of current that can be output using the equation: Capacity x Discharge Rate = Current Output, the batteries will be compared. The results are listed in Table 3.2.12.A.

Looking at these results, the three lithium-polymer batteries are qualified since they meet the current requirement. It is advised not to discharge more than 80% of a battery's capacity to keep the battery healthy (r helicopter fun). The lithium-polymer batteries also meet this suggestion. All of the batteries are less than half a pound, which is a reasonable weight that won't add extra stress to the robot's frame. Ignoring the discharge rate since they are all the same for lithium-polymer, the best price per capacity ratio was compared. The Hunger Lipos battery has the best at 6.15 \$/Ah compared to 14.8 \$/Ah and 16.6 \$/Ah for the Thunder Power 2700 and 3100, respectively. However, the Hunger Lipos battery is over 50% heavier than the Thunder Power batteries.

An important specification to know is the battery life of the robot when using these batteries. The maximum battery life at full operating current can be calculated by this equation: (Capacity * 60 minutes) / Operating Current. At the robot's maximum current load, the battery life of the batteries are shown in Table 3.2.12.A. The battery life is concerning because the average of 5 minutes is not a very long time. The results above are assuming the robot is using the maximum current at all time.

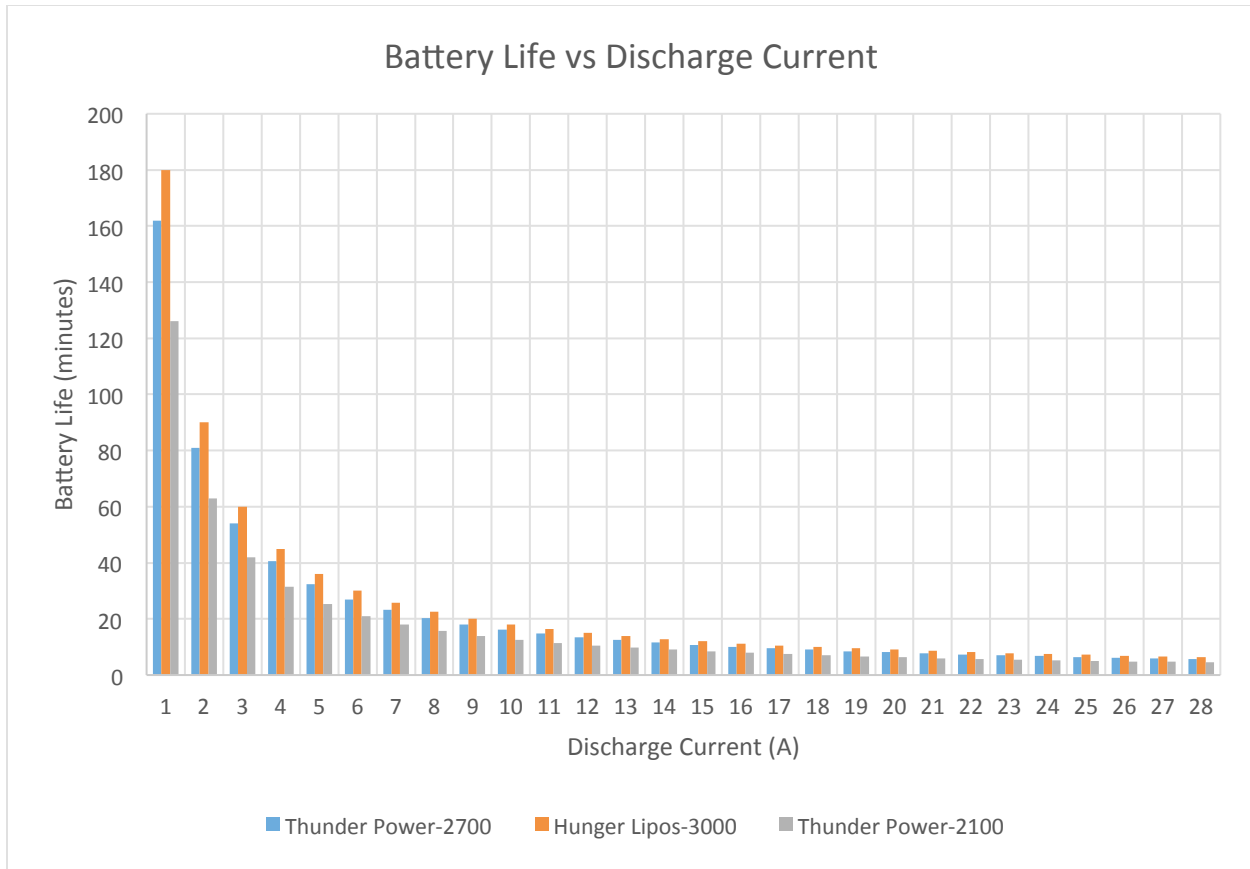

Figure 3.2.13.B - Battery Life Versus Discharge Current

A more accurate representation of battery life would be when the current varies. A plot is shown above in Figure 3.2.12.B, which compares the three lithium polymer batteries' battery life when the discharge current varies. The graph shows that the Hunger Lipos battery has the longest battery life, which is due to its higher capacity.

The battery that will be chosen for this project is the 3000 mAh Hunger Lipos. This battery was chosen because it meets all of the voltage and current requirements for the subsystems. It also has the longest battery life and the best price per capacity ratio. The only downside is the greater weight than the other batteries but it is marginal.

3.2.14 Photovoltaic (PV) Cells

Crystalline Silicon: Crystalline silicon used today makes up about 90% of all solar panels in the market. The purity of the silicon is important because the better the crystal structure, the more efficient the solar panel will be at converting sunlight into electricity. However, increasing the purity of silicon can be very expensive. There are two types of crystalline silicon, mono-crystalline and poly-crystalline.

Monocrystalline: Monocrystalline solar panels are made using single crystal solar cells. They are made using cylindrical silicon ingots which are then cut similar to an octagon to lower cost and increase efficiency. The advantages are that they have the highest efficiency out of all other

solar panels because they have the highest purity. They are also more compact than other solar panels since they produce more power. Also, they usually have the longest lifespan of over 25 years. Lastly, when sunlight is not very intense, they may perform better than other solar panels. A major disadvantage of monocrystalline solar panels is that it is the most expensive out of all the other solar panels. Additionally, different weather conditions can cause damage to the panels, such as snow and dirt. Also, the efficiency of these solar panels depends on temperature.

Polycrystalline: Polycrystalline solar panels are made using multi-crystal solar cells. They are made by melting silicon and pouring it into a mold, which is cooled and then cut up into squares. This manufacturing processes reduces the amount of wasted silicon and is cheaper to produce. The major disadvantage in using polycrystalline solar panels is that the efficiency is only about 13-16% because the silicon has a low purity. Additionally, these solar panels require more space to output the same amount of power as monocrystalline solar panels.

Thin-Film Solar Cells: Thin-film solar cells are made by incorporating thin layers of photovoltaic material onto a substrate. There are three main types of photovoltaic material that can be used to make them. They are amorphous silicon, cadmium telluride, and copper indium gallium selenide. The efficient of thin film solar cells are about 7-13%. The advantages of thin-film solar cells are that they are easier to manufacture compared to crystalline based solar cells and cheaper. They can be made flexible which introduces more possible uses. They can also withstand higher temperatures without affecting efficiency. The disadvantages of thin-film solar cells are that they degrade faster than monocrystalline and polycrystalline solar panels, and that they require more space to equate to the power output of other types of solar panels.

Amorphous Silicon: Amorphous silicon solar cells usually have low electrical power and are typically used in small devices, such as calculators. They have been in the market for over 15 years, and they have an efficiency rating of about 6-8%. The low efficiency rating is a major disadvantage of using amorphous silicon solar panels. They also have a shorter lifetime than crystalline solar cells. One advantage of amorphous silicon is that it is cheap to manufacture. Another advantage is that amorphous silicon is resistant to impurities affecting it since it is naturally impure already. Amorphous silicon comes in many different shapes and sizes, so they can be used in many different applications. Also, these solar cells can be arranged together to output a specific voltage.

Cadmium Telluride: Cadmium telluride solar cells are highly cost efficient compared to crystalline silicon. Their efficiency is typically 9-11%. These cells are rapidly growing and are the second most used solar cell in the market. The main advantage is that they are cheaper to manufacture compared to silicon cells. Also, cadmium is abundant, which also benefits the cost to prepare them. One disadvantage is that the efficiency is lower than silicon cells. Also, tellurium is not abundant and is a rare element. Another disadvantage is that cadmium is very toxic.

Copper Indium Gallium Selenide: Copper indium gallium selenide solar cells are also highly efficient. They have an efficiency rate in the range of 10-12%. The advantage of copper indium gallium selenide is that it can be manufactured onto glass or steel. Also, they can be made

flexible. It also has a good resistance to heat in comparison to silicon cells. The main disadvantage is that they are expensive to manufacture.

Based on the research of the different types of solar panels, monocrystalline silicon sounds like the best choice. Although expensive, they have the best efficiency rating out of all other solar cells. Also, they provide much more power than other solar cells, which means that a smaller monocrystalline solar panel can be used and produce the same amount of energy than a larger solar panel made from one of the less efficient materials. Monocrystalline silicon also has a very long lifespan, which reduces the risk of solar cell malfunction.

Choosing a Solar Panel: Now that the battery has been chosen, an appropriate solar panel can be researched. The battery will operate at a nominal voltage of 7.4V, so the solar panel voltage needs to be slightly higher than 7.4V. This is because if the battery voltage is higher than the solar panel voltage, the diode in the solar panel will be reverse biased. This won't allow current to flow into the battery to charge it. Also, it prevents the solar panel from draining the battery. The types of solar panels that will be considered are crystalline silicon solar cells because they offer high efficiency, while being compact. The candidates for the solar panel are shown below in Table 3.2.14.A. Multiple parameters are compared to each other to decide which one to use. The data taken was from the STC (Standard Test Conditions), not from NOTC (Normal Operating Test Conditions.) The average power the solar panel will produce under NOTC would be about 75% of the STC (amsolar).

Table 3.2.14.A - Comparison of Solar Panels

Manufacturer	Solartech Power Inc.	Solartech Power Inc.	Ledtronics
Model Number	SPM010P	S01PC-15	SLR-PNL-10W-101
Price	\$69.95	\$39.95	\$29.75
Maximum Power	10 W	15 W	10 W
Nominal Voltage	12 V	12 V	12 V
Operating Current	0.59 A	0.85 A	0.84 A
Efficiency	9.5%	10.78%	N/A
Weight	3.3 lb	3.3 lb	3.52 lb
Area (in ²)	176.9	216.6	170.2
Crystal Structure	Polycrystalline	Polycrystalline	Monocrystalline

After examining the results, it became clear that all of the solar panels meet the requirement of operating great than 7.4V. The monocrystalline solar panel seems to have a high efficiency because it outputs as much current as the 15W polycrystalline. However, it is not explicitly stated in the datasheet and therefore this panel will be avoided. The two polycrystalline solar panels from Solartech both have similar specifications. However, the 15W panel has a greater efficiency and a higher operating current. They both have the same weight, so it doesn't need to be considered. The price for the 15W panel is also 20 dollars cheaper which makes it a good option. The footprint of the 15W panels is greater than the 10W panel by 39.7 square inches.

The solar panel that will be chosen for this project is the Solartech 10W panel. This solar panel was chosen because the specifications were similar to the 15W and it has a smaller footprint.

This will allow our robot to not be very large. The main deciding factor in choosing this panel is that it is already obtained.

3.2.15 Maximum Power Point Tracking

Maximum Power Point Tracking, also known as MPPT, is an electronic device that controls a solar panel to output the maximum amount of power. These devices convert a solar panel's higher DC voltage to a lower DC voltage that the batteries require to recharge. The charge controller monitors the output voltage of the solar panel and compares it to the voltage of the battery. It then figures out the maximum power the solar panel can output. Once it finds out the maximum power, it converts the voltage in order to get the most amperage out of the solar panel. A graph of maximum power point tracking is shown in Figure 3.2.15.A below. The maximum power point of the solar panel is the peak of the green line. Once that maximum is found, the controller adjusts the output to match it.

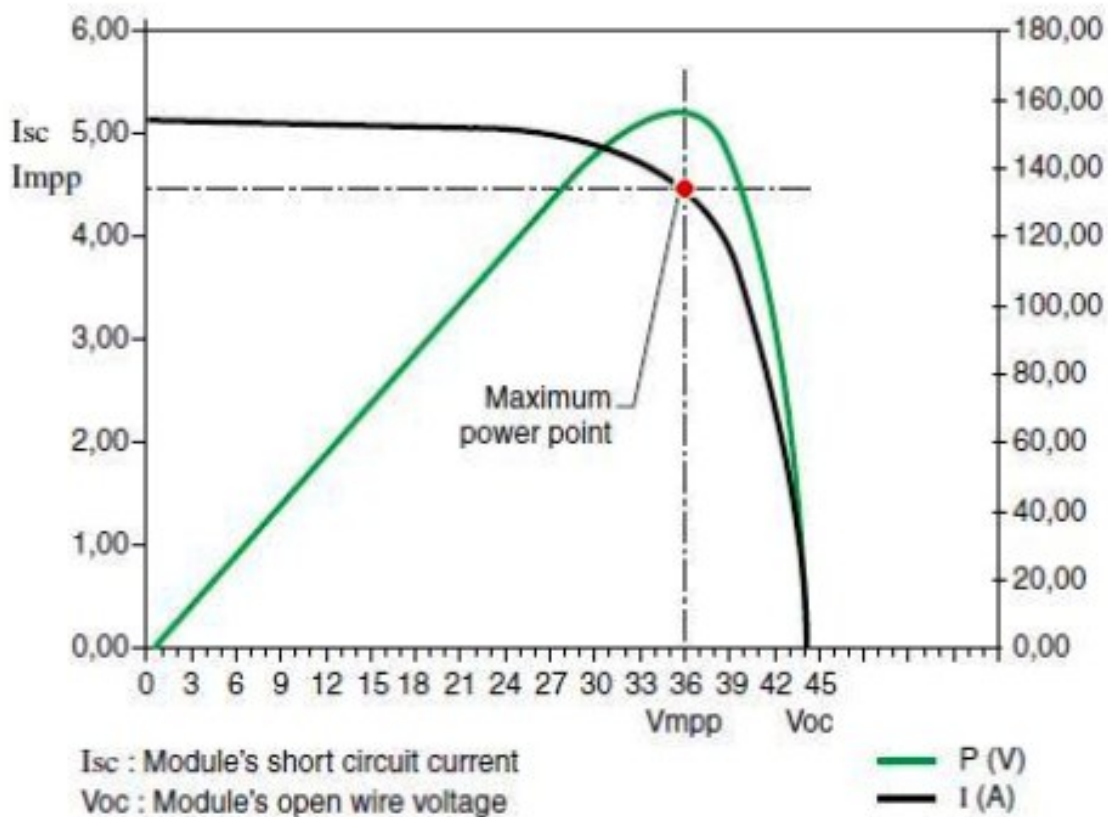

Figure 3.2.15.A - Maximum Power Point of a Solar Panel
Permission Pending

Here is an example of why maximum power point tracking is important. Let's assume there is a solar panel rated at 50W, a voltage of 15V, and 3.33 amps of current. If this solar panel is connected through a normal charge controller to a 9V battery, it will force the solar panel to operate at 9V. Thus the solar panel will deliver 3.33 amps at 9V. Using the equation for power, where power is equal to current multiplied by voltage, the output power would be $P = 3.33 * 9$,

which is about 30 Watts. As seen from the calculations, the solar panel only produced 30 Watts of power, instead of the 50 Watts it is rated at. The extra 20 Watts is not produced because there is a poor mismatch between the solar panel and the battery.

Now, let's assume this solar panel is connected to the battery using maximum power point tracking. The same 50W solar panel will be connected to a 9V battery. The maximum power point will be found, and the solar panel will output 9V at 5.55 amps. The amount of amps that will charge the battery can be used with the equation: Battery Charging Current = Solar Panel Voltage / Battery Voltage * Solar Panel Current. So $15V/9V * 3.33A = 5.55A$. Using the equation for power: $P = 5.55 * 9$, is about 50 Watts. Therefore, there is a 100% power conversion, ideally. The tracker does this continuously to get the most power.

Internally, a maximum power point tracker uses a DC-to-DC converter with a high frequency. The DC voltage from the solar panel is inverted into AC, and then rectifies the voltage into a different DC voltage and current to match the battery to the solar panel. These trackers use frequencies in the range of 20 kHz to 80 kHz. The advantage of using a high frequency is that it enables the power conversion to be more efficient. The disadvantage is that it can cause interference with other signals. This may cause a problem for our sensors because they usually operate within those frequencies. Therefore, noise isolation will have to be considered when using maximum power point tracking. Maximum power point tracking is also great because of potential varying weather conditions. It will help to achieve the maximum power available in every condition.

3.2.16 Charge Controllers

Charging lithium batteries can be challenging. Many lithium batteries have charging protection circuits built in to prevent them from exploding. While it is possible to directly connect the solar panel across a lithium battery for it to charge, it will be very inefficient and take a very long time. This is because the solar energy varies depending on how much sunlight it receives, and thus it is not a guarantee that the solar panel will be receiving enough light at any time in order to produce a charge. In order to extend the lifetime of lithium batteries, they should be treated carefully. Overcharging them can cause the battery lifetime to decrease dramatically. This includes charging the battery for too long, or charging the battery at a very high voltage. On the other hand, undercharging the battery can also reduce that batteries capacity.

Another parameter that affects the lifetime of lithium batteries is the operating temperature. When the battery is at a low temperature, the electrolytes in the battery can freeze when the battery is dead. When the battery is at a high temperature, the chemicals can break down and destroy the battery. The graph in Figure 3.2.16.A below depicts the effects of temperature on the capacity of lithium batteries. There is a direct relationship between temperature and battery capacity; as the temperature decreases, the capacity decreases greatly over the battery's operation.

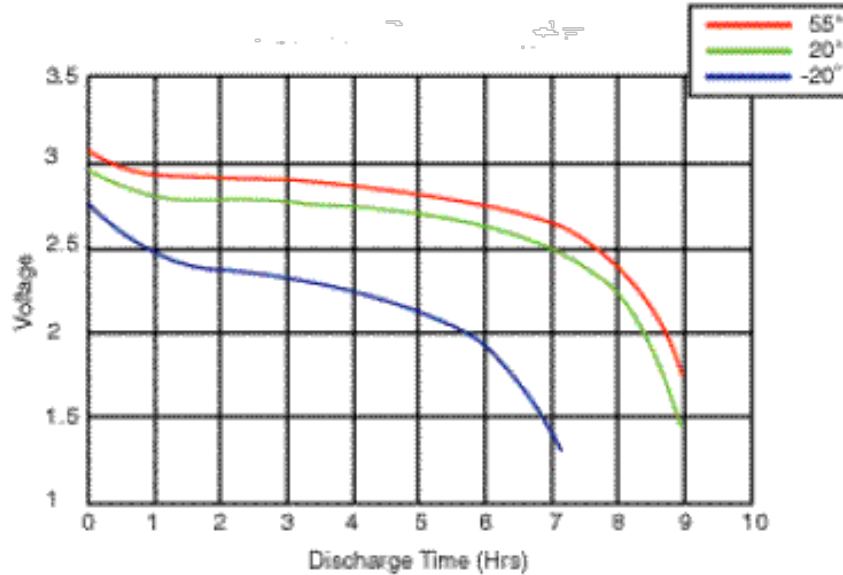

Figure 3.2.16.A - Battery Voltage Over Discharge Time At Various Temperatures

Lithium polymer batteries require an intricate charging process. They are charged using a method called constant-current / constant-voltage. This includes 5 steps in order to successfully charge the battery. These include: pre-conditioning, constant current, constant voltage, charge termination, and standby mode.

Step 1: Pre-conditioning: Using a 4.1V lithium polymer battery as an example, let's assume the battery has been extremely depleted to the point where the voltage becomes less than 3V. This usually occurs when the battery is left on for too long and the cell essential dies. In order to charge the battery, the cell needs to be rejuvenated first. The battery is charged under pre-conditioning phase, which only charged the battery at about 0.1C. It is charged until the cell reaches a certain voltage and is able to withstand the all of the current in the constant current phase. This pre-conditioning phase helps to prevent the cell from overheating also.

Step 2: Constant-Current: Once the battery has completed pre-conditioning, it enters a constant current phase. In the constant-current phase, the battery is charged at a maximum rate of 1C. When the battery reaches its voltage of 4.1V, the constant-current phase transitions into the constant-voltage phase. The charge rate can be less than 1C and is advantageous to charge it at a slower rate. For example, if the battery is charged at 0.8C, by the time it reaches 4.1V, it only has a capacity of about 60%. However, if the battery is charged at 0.20C, when it reaches 4.1V, the capacity can be very close to 100%. The downside is that charging it at a slower rate takes longer to charge.

Step 3: Constant-Voltage: When the constant-current phase has reached 4.1V, it switches to a constant-voltage mode. It switches to this mode to prevent the battery from overcharging. The current steadily decreases while in the constant-voltage phase.

Step 4: Charge Termination: Once the charge rate reaches 0.1C, charging is terminated and the battery is fully charged. However, the battery can discharge itself over time. This is where topping it up comes into play.

Step 5: Charge Top-Up: The top up charge process occurs when the battery discharges to a certain level, usually around 3.9V or lower. The battery gets charged again until it reaches 4.1V.

The graph in Figure 3.2.16.B depicts the charging cycle of a lithium polymer battery. As shown in the figure, the battery starts off in a pre-conditioning phase, which then transitions into the constant current phase. When the battery reaches 4.1V, it transitions into the constant voltage phase. And when the charge current reaches 0.1C, charging terminates. Then the battery gets topped off when the voltage decreases.

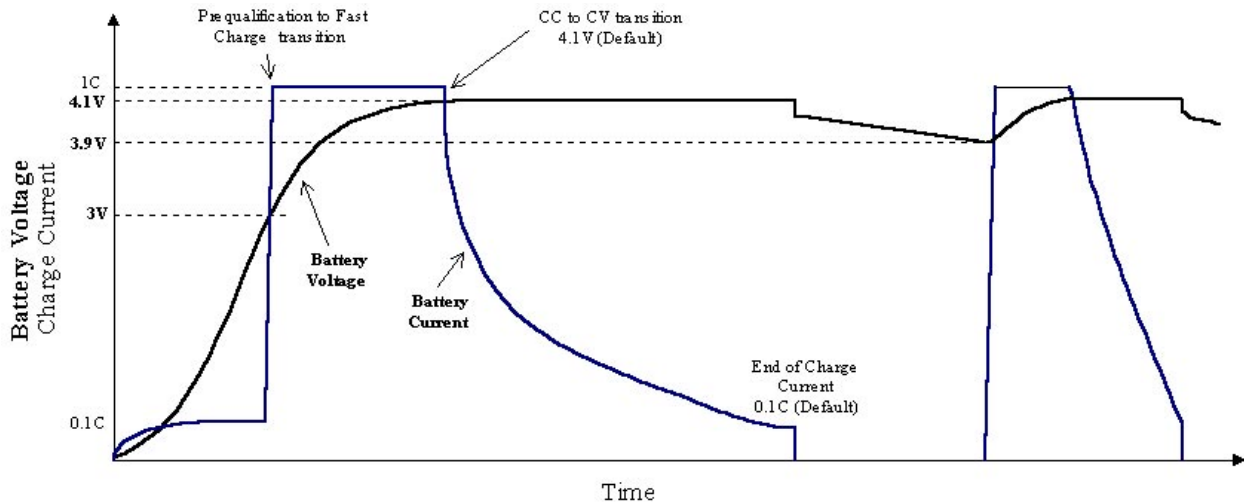

Figure 3.2.16.B - Lithium Polymer Battery Charging Cycle
Permission Pending

Choosing a MPPT Charge Controller: With the solar panel chosen, an appropriate solar panel charging controller can be selected. The ones that will be researched are the controllers that have a maximum power point tracking feature. This is needed in order to allow the solar panel to run optimally, so that the maximum power can be achieved. Other features that are beneficial are controllers that implement the pre-conditioning, constant-current, and constant-voltage charging method. Also, a controller that measures the battery temperature will help to know when the battery is overheating. And overcharging protection will be needed to help preserve the battery lifespan. Two charge controllers have been researched and are compared below in Table 3.2.16.A.

Table 3.2.16.A - Comparison of MTTP Charge Controllers

Manufacturer	Texas Instruments	Linear Technology
Part Number	bq24650	LT3652
Price	\$5.96	\$6.53
Input Voltage-Solar Panel	5-28 V	4.95-35 V
Charge Rate	Up to 10 A	Up to 2 A
Safety Features	Yes	Yes
Package	QFN-16	MSOP-12 or DFN-12

Both charge controllers offer maximum power point tracking which is needed. Also, they both offer a wide range of input voltages that meets the voltage of the chosen solar panel. Additionally, they both offer safety features, such as battery temperature monitoring. If the battery temperature is out of the boundaries, both battery controllers will stop charging until it goes within boundaries. The Texas Instruments charge controller has additional safety features, such as overvoltage protection and battery absence detection. The charge controller also has a programmable charging rate of up to 10 Amps, while the Linear Technology one is only up to 2 Amps. The TI chip comes in a QFN-16 package which is difficult to test, while the LT chip comes in an MSOP-12 package which is much easier to work with. The TI chip is cheaper than the LT chip by 54 cents but that is negligible.

The maximum power point controller that will be used for this project is the Texas Instruments bq24650. This one was chosen because it offers a few more safety features than the LT chip. Also, it supports 5 times more current than the LT chip in case the battery needs to be charged faster. The downside of choosing this chip is that it will be more challenging to design.

3.2.17 Voltage Regulators

This project has many subsystems that each requires different voltages. However, a battery only supplies one specific voltage. Suppose the battery supplies 12 volts and each subsystem requires 3.3, 5, and 9 volts; how will this battery power each subsystem? The solution to this problem is to use voltage regulators. Voltage regulators provide a constant DC output regardless of the load current and the input voltage, as long as they are in the operating range. There are three main types of voltage regulators that will be discussed, which are linear regulators, switching regulators, and zener diode regulators.

Linear Voltage Regulator: Linear voltage regulators are a simple way to convert from a higher voltage to a lower voltage, so that each subsystem receives the correct amount. They are very easy to use and they are also very inexpensive. These regulators are used mainly in low power applications. Most linear regulators work by using an operational amplifier to compare the output of the regulator to a voltage reference. The amplifier will then increase or decrease the output to match the reference voltage.

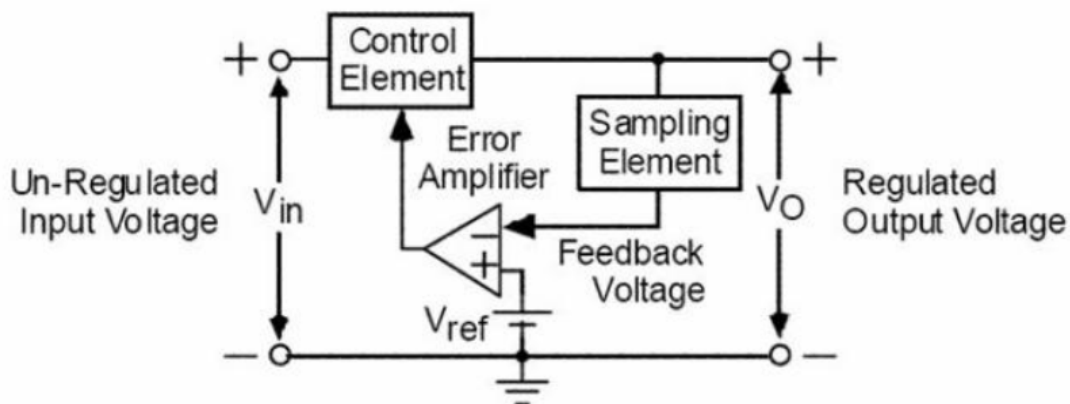

Figure 3.2.17.A - Linear Voltage Regulator Circuit
Permission Pending

In Figure 3.2.17.A above, a linear voltage regulator circuit is shown. The output of the regulator is sampled usually with a resistor divider. The error amplifier compares the voltage to V_{ref} . If the sampled voltage is higher than the reference voltage, the amplifier will decrease its output. If the sampled voltage is lower than the reference voltage, the amplifier will increase its output. The error amplifier then sends this corrected voltage through the control element, which is usually a transistor.

Although linear regulators are simple and cheap, they are also very inefficient. This is because the power going into the regulator is greater than the power coming out of the regulator. Any excess power has to be dissipated in the regulator. This power dissipation within the regulator causes the device to increase in temperature. To help dissipate the heat, a heat sink can be used to keep the temperatures cool.

Linear regulators have a maximum power dissipation parameter, which can be found in the datasheet. This is the maximum amount of power that can be dissipated in the regulated via heat. The power dissipated in the regulator can be calculated using the following equation : $P_{reg} = P_{in} - P_{out}$. $P_{in} = V_{in} * I_{in}$ and $P_{out} = V_{out} * I_{out}$. The efficiency can be calculated using the equation: $Efficiency = (P_{out}/P_{in}) * 100$. Assume a 12V battery is used with a 5V regulator and a load current of 1A. The power dissipated in the regulator would be: $P_{reg} = 12 * 1 - 5 * 1 = 7$ Watts. And the efficiency would be: $Efficiency = (5/12) * 100 = 41.6 \%$. One way to increase the efficiency is to decrease the input voltage, so that it's closer to the regulated voltage. Assuming a 6V battery is used with the same regulator and load current. The efficiency would now be 83.3%.

However, linear regulators have a parameter which requires a minimum input voltage. This is known as the dropout voltage. The dropout voltage is the amount of voltage required above the output voltage to successfully regulate the output. The minimum voltage needed can be calculated using the equation: $V_{in}(\text{minimum}) = V_{out} + V_{do}(\text{dropout voltage})$. For example, if a 5 volt linear regulator has a dropout voltage of 2 volts. The minimum input voltage would have to be : $V_{in} = 5 + 2 = 7$ volts for proper regulation. There is a type of linear regulators called low dropout regulators, which have a low dropout voltage. Therefore, the user can apply an input voltage much closer to the regulation voltage. However, low dropout regulators can be unstable, so much care has to be taken into account with added capacitors.

Switching Voltage Regulator: Switching voltage regulators are similar to linear regulators because they can step down the voltage from a higher input to a lower output. They are a little bit more complex and expensive since they require storage elements, such as inductors and capacitors. They are very efficient and can range more than 90% efficiency. A high efficiency also means that less power will be wasted within the regulator, resulting in less heat. Therefore, a smaller heat sink can be used compared to a linear regulator, or in some cases a heat sink will not be required. In addition to stepping down voltages, they can also step up voltages from a lower input to a higher output voltage.

Switching regulators work by utilizing a switch, usually in the form of a pulse width modulator. The switch opens and closes periodically, sending the energy from the input to the output. The switch is controlled by sampling the output and comparing it to a reference voltage. When the

output voltage is lower than the reference, the pulse width has to be reduced. When the output voltage is higher than the reference, the pulse width has to be increased.

When the switch is closed, the diode is reverse biased and current flow through the inductor and energy gets stored in the magnetic field. When the switch is open, the diode is forward biased and the energy stored in the inductor keeps current flowing to the output. In a switching regulator, the input and output currents are not the same. The output actually has more current than what is supplied from the input. This is why these regulators are more efficient than linear regulators. Since the switching regulator is being switched frequently, they tend to have ripple in the output voltage. One way to solve the switching regulator's voltage ripple problem is to connect a linear regulator in series with it. The linear regulator will take the rippled voltage into the input and provide a constant DC voltage at the output.

Zener Diode Regulator: Another type of regulator is the zener diode regulator. Zener diodes are used in reverse bias in order to keep a constant voltage. The regulated voltage is equal to the diode's breakdown voltage. These regulators are accompanied by a resistor, which sets the amount of current flowing through the diode. The voltage across the diode will be constant as long as the input voltage is a little greater than the output voltage. The output voltage of the diode does not depend on current. If the resistor value is decreased, more current will flow through the diode but the voltage will not change. The advantage of using this regulator is that it is a simple circuit and only requires two components. Also, these components are very cheap. The disadvantage of using this regulator is that noise can be generated when it is trying to regulate the voltage.

4.0 Hardware & Software Design Details

4.1 Initial Design Architectures and Related Diagrams

The Wi-Fi Seeker has many functions that require many subsystems. However, there is a physical abstraction that should be discussed so that it is clear how the subsystems interact and how they will be physically put together to form the final robot. In Figure 4.1.A the Wi-Fi Seeker is shown as being decomposed into three physical subsystems: the Android, Power, and Robot subsystems. The Android subsystem consists of the Android application, which will wirelessly communicate with the IP camera and the Bluetooth module on the robot. The power subsystem consists of the solar cell and the lithium polymer batteries it charges, which will be used to power all of the components in the Robot subsystem, but does not affect the Android device. Finally there is the robot subsystem. Here the main hardware is the MSP430F5529, which will connect to and control the wireless module, the Bluetooth module, the motors, and the sensors. The IP camera will be in close proximity to the hardware in the robot subsystem, but it will not communicate with the Android device by going through the MSP430F5529 microcontroller.

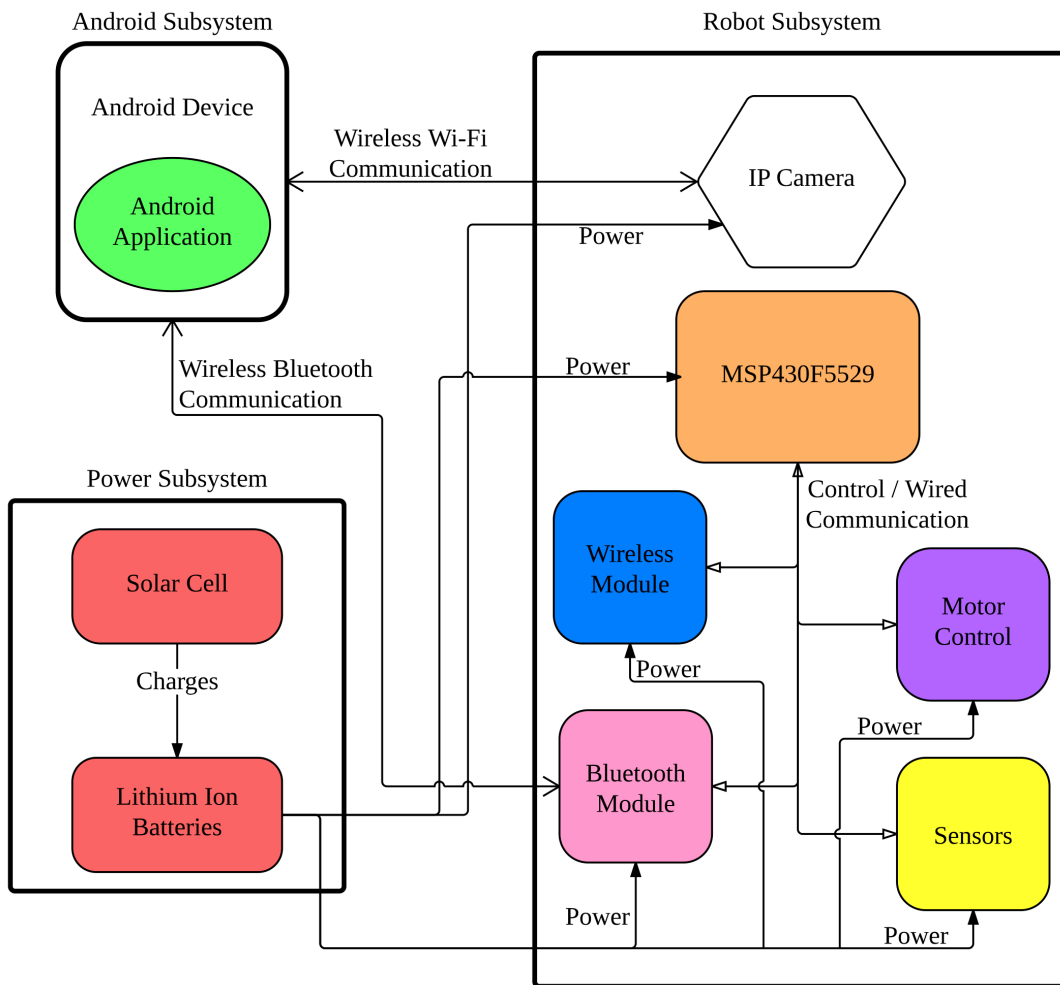

Figure 4.1.A - Physical Abstraction of the Wi-Fi Seeker's Components

4.2 Sensors Subsystem

Taking into consideration all of the information noted in the research section, it was decided to use both the Infrared Proximity sensors and Ultrasonic Proximity Sensors for the Wi-Fi Seeker robot. These sensors will be used together in order to make up for the disadvantages that each of the sensors suffer when used alone, and will allow the robot to be used in both indoor and outdoor environments. One of each sensor will be placed at the front and rear of the Wi-Fi Seeker robot chassis, since the robot will have both forwards and backwards motion.

4.2.1 Infrared Proximity Sensor

The Sharp GP2Y0A21YK Infrared Proximity Sensor is the type of infrared sensor that was chosen. This sensor will be attached directly to the MSP430F5529 microcontroller with a Japanese Solderless Terminal (JST) Connector. This will allow the sensor to provide an analog signal in order to relay information about obstacle to the microcontroller.

4.2.2 Ultrasonic Proximity Sensor

The HC-SR04 Ultrasonic Proximity Sensor will be the ultrasonic sensor that will be used in parallel with the infrared proximity sensor. It will also be attached directly to the microcontroller and will provide an analog signal to relay information to the processor about obstacles.

4.3 Motion Subsystem

4.3.1 Motors

The motors that will be used for the Wi-Fi Seeker are an extremely important because they are what will make the robot move, which is crucial to its functionality. The motors will need to be powerful enough to pull the weight of all of the electrical components, as well as the batteries, circuit boards, and solar panels. Also they will need to be able to travel at an average human walking pace (about 5 km/h). The motors will be connected to the H-bridge circuit which will be connected to the microcontroller. The robot chassis for the Wi-Fi Seeker robot comes with motors preinstalled. Since the robot chassis is more heavy-duty, the motors that come equipped are well suited for powering a heavier robot, and thus will be a good fit for the Wi-Fi Seeker robot once all of its subsystems are successfully mounted on the robot body.

4.3.2 Motor Controller

Instead of using a costly motor controller that covers a broader range of applications and has many features that will not be used by the Wi-Fi Seeker robot, a motor controller will be designed in order to fit the specifications of the robot. The motor controller will be capable of generating its own PWM signal for speed control. This method will allow the robot to save on processing power for the microcontroller since the microcontroller will only need to send out a simple analog signal rather than multiple PWM signals for each of the individual motors. The robot will

be equipped with an MSP430F5529 that will generate the signal to control the speed and rotation direction of the motors. It will control the rotation direction by altering the H-bridge relay. The microcontroller will use two signals to control the motor movement. The first signal will be a digital signal that will control the direction of rotation. The signal will control which of the transistor the H-bridge relay will allow current to flow through. As a result the direction of rotation will be dependent on the signal. The second signal will be an analog signal that will control the duty cycle of the PWM being generated. The duty cycle of the PWM will determine the duration that the current can flow during each cycle.

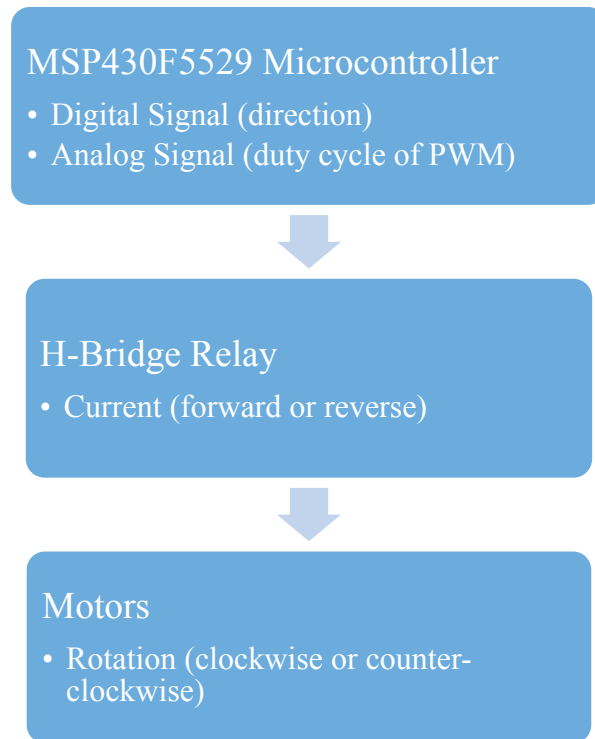

Figure 4.3.2.A - Motor Controller Flow Chart

The full design for the Dual H-Bridge will use bi-polar transistor in place of the switches shown in a basic H-Bridge configuration. A multimeter will be used in place of a DC motor. Diodes are then added in parallel to the transistor in order to prevent damage to the circuit and prevent the power supply from having the motor generating and transferring unwanted energy. The diodes provide a short-circuit discharge path that will dissipate the energy generated by the motors stopping. A capacitor is also added to serve as a local energy source, which will provide some energy when the motors are turn on and to store some energy when the motors are turned off. In short, it will help smooth out the voltage spikes. The resistors are used to control the amount of current available to the motors. Finally, another transistor was added to be an overall enable line to add PWM to control speed. Pulsing this will make the motor run only while the control is high so the user will not have to worry about which direction the motor is running. To ensure that the circuit does not overheat, heat sinks may need to be added if the transistor gets too hot.

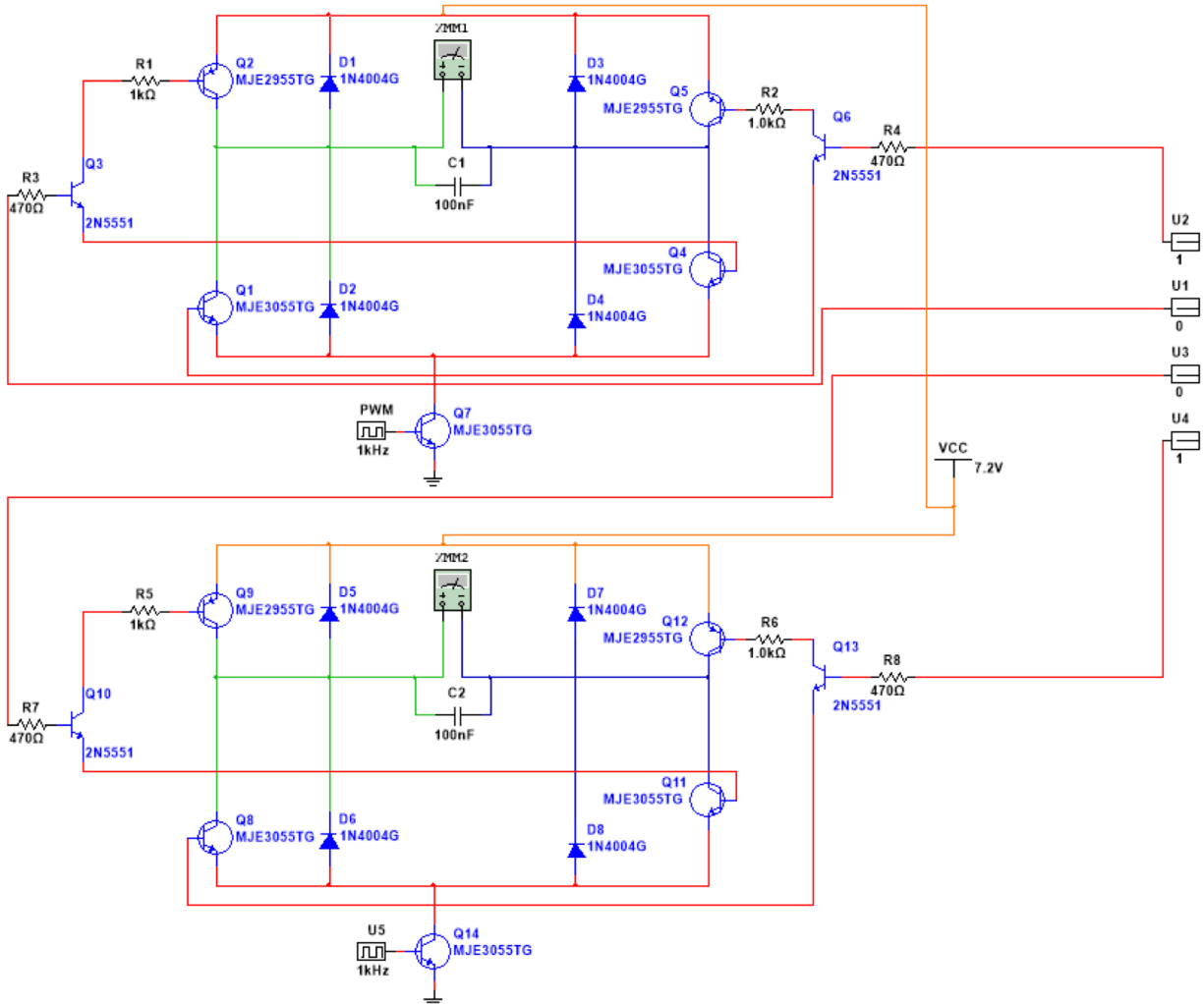

Figure 4.3.2.B - Full H-Bridge Schematic For Wi-Fi Seeker Robot

The MJE2955TG PNP and MJE3055TG NPN bipolar junction transistors were chosen to be used in the full H-bridge design. These devices are rated to handle a maximum collector-emitter voltage of 60 V. They can handle a maximum DC current gain of 10 A. The 2N5551 NPN bipolar transistor can handle a maximum collector-emitter voltage of 160 V and a maximum continuous DC current gain of 600 mA. The capacitor chosen will have a voltage rating of at least twice the typical load to ensure that it isn't overloaded during operational changes. The prices in Table 4.3.2.A below show that four motor controllers can be made for less than the price of buying a motor controller unit.

Table 4.3.2.A - Table of motor controller components and prices.

Component	Amount	Price per unit	Total
MJE2955TG	2	\$0.3514	\$0.7028
MJE3055TG	3	\$0.3387	\$1.0161
1N4004G	4	\$0.0138	\$0.0552
2N5551	2	\$0.044	\$0.088
Resistor (1k)	2	\$0.0184	\$0.0368
Resistor (470k)	2	\$0.0501	\$0.1002
Capacitor (100nF)	1	\$0.0512	\$0.0512
		Total for one	\$2.0503
		Total for two	\$4.1006

In order to establish power to the H-Bridge a 7.4V DC power source will be supplied. Additionally, in order to provide a PWM signal to the H-Bridge, the circuit will be connected to pins 42 and 43 on the MSP430F5529 microcontroller. Finally, to control the direction that the motors will rotate, pin 23, 24, 25, and 26 on the MSP430F5529 microcontroller will be used to control the current flow.

4.4 Android Application Subsystem

The Android application for the Wi-Fi Seeker is extremely important because it is the controller for the robot itself. The application will allow the user to start the autonomous functionality of the Wi-Fi Seeker, watch the video stream from the IP camera mounted on the robot, view other status information about the robot, stop autonomous mode, and allow for manual mode where the user can directly control the robot's motion. The very first thing that the application checks for on startup is a connection to the Internet over Wi-Fi. If the Android device is not connected to a Wi-Fi network, the application will notify the user to close the application and connect to a wireless network before re-launching the application. Once the application is open, the initial setup must be completed before the user can start controlling the robot. This setup involves initializing the connection between the wireless module located on the robot by connecting it to a wireless network, as well as connecting the IP camera to the Android application. Therefore the very first time that the Wi-Fi Seeker Android application is launched, the user will be prompted to complete initial setup, which will involve steps for initializing the wireless module followed by connecting the IP camera. Figure 4.4.A depicts a preliminary mockup of what the initial wireless module setup will look like, which will allow the user to get a list of available wireless networks and select one to connect to before continuing the setup. Figure 4.4.B depicts a preliminary mockup of what the initial camera setup will look like, which will permit the user to be able to enter the camera's IP address and then be able to check that the camera is working properly before completing the setup.

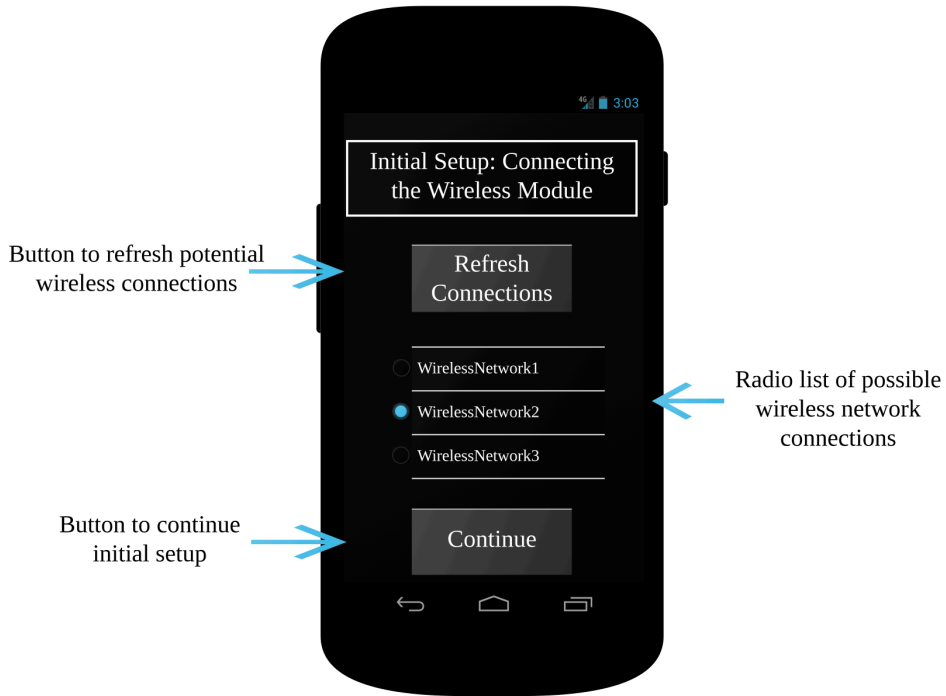

Figure 4.4.A - Android Initial Wireless Module Setup

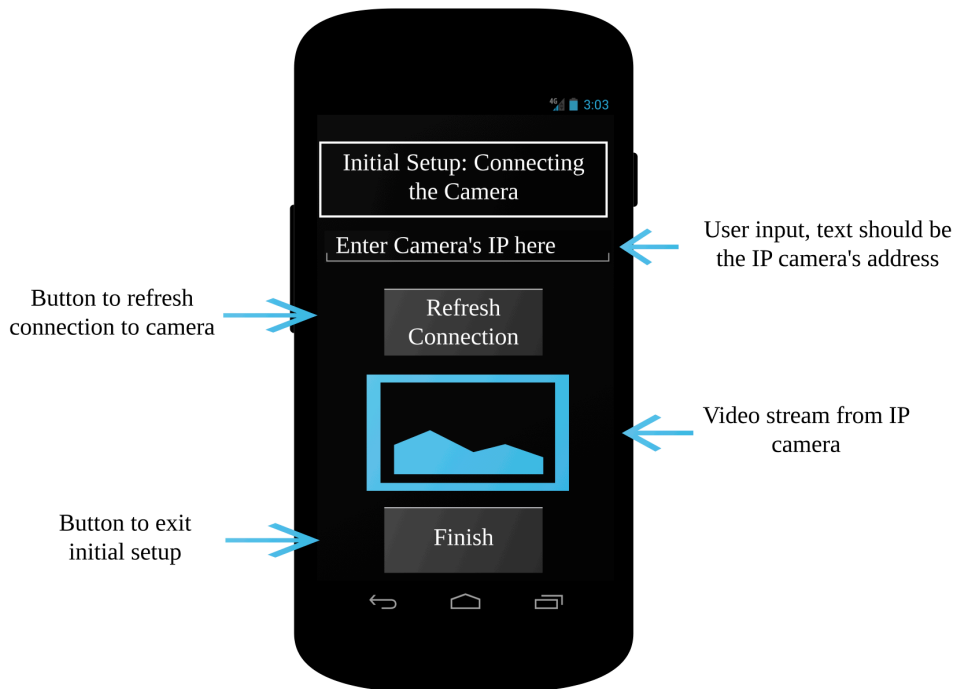

Figure 4.4.B - Android Initial Camera Setup

Once the initial setup is complete, the user will be brought to the main screen of the application, which shall hence be referred to as the Main Activity. The Wi-Fi Seeker robot will have to modes of operation: manual and autonomous. When the robot is roaming about and measuring the signal strength as it determines the location where the Wi-Fi signal is strongest, the robot is

in autonomous mode. The robot is in manual mode when the robot is not moving on its own; in this mode the robot is either sitting still waiting for a user command, or is being manually operated by the user. The difference between these modes, in terms of what is displayed on the Android application, is the control. For manual mode, the application requires an additional four buttons to indicate controls to make the robot move in the forwards, left, right, and reverse directions. For autonomous mode, the control buttons are removed. The preliminary mockup for the Main Activity is shown in the figures below, with the user interface for manual mode shown in Figure 4.4.C and the user interface for autonomous mode shown in Figure 4.4.D.

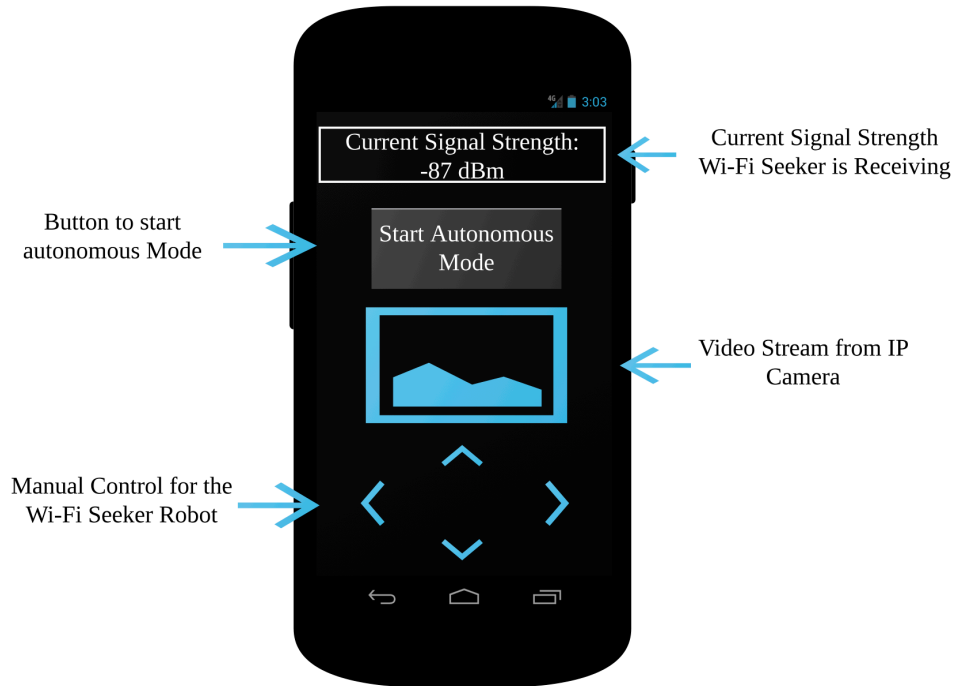

Figure 4.4.C - Android Main Activity: Manual Mode

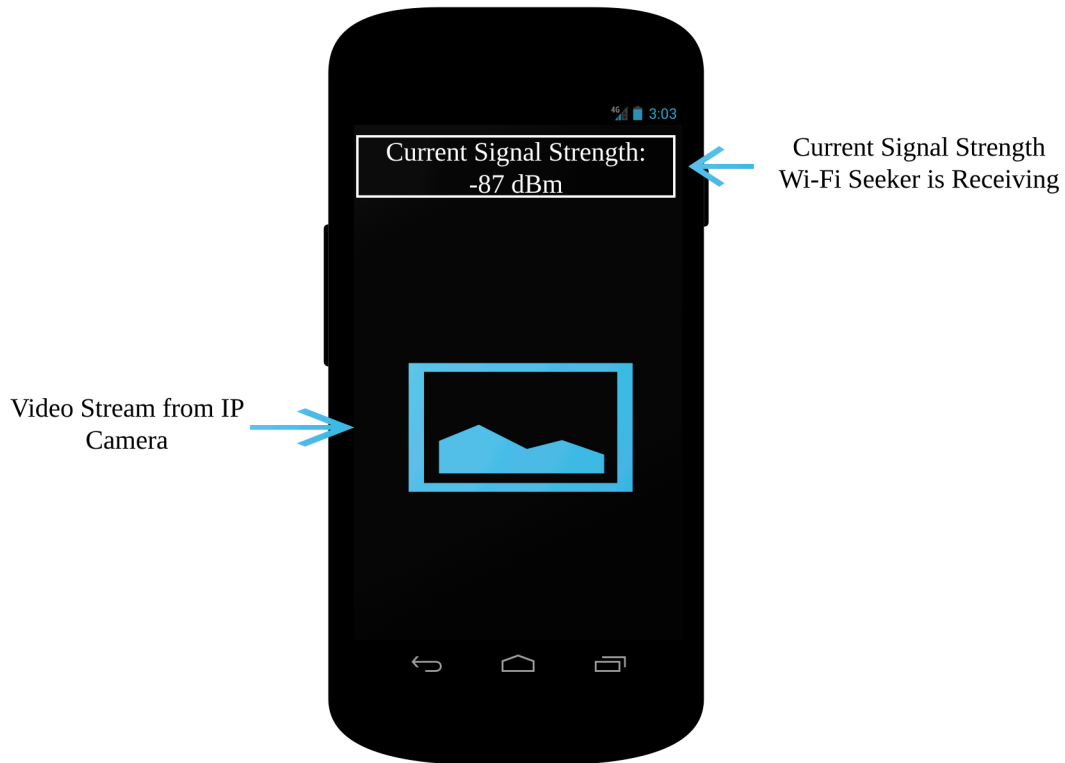

Figure 4.4.D - Android Main Activity: Autonomous Mode

From within the Main Activity, the user can toggle between manual and autonomous modes by pushing the button to either start or stop autonomous mode, respectively. If the user is in manual mode, s/he can see the current signal strength that the Wi-Fi Seeker is measuring, as well as the video feed from the robot. Pressing any of the four motion buttons will cause the robot to act accordingly. For example, pushing the forward and left buttons will cause the robot to turn left. Should the user push the "Start Autonomous Mode" button, the robot will begin its autonomous quest and the Main Activity in the application will update to autonomous mode. If the user is in autonomous mode, s/he can see the current signal strength of the wireless signal being measured as well as the video feed from the robot. The only button on this screen is to stop autonomous mode, which would preemptively stop the Wi-Fi Seeker's quest and return the user to manual mode. At this point the Main Activity in the application would update to reflect manual mode. Should the robot be allowed to stay in autonomous mode until it has successfully found the location where the strongest Wi-Fi signal for the wireless network the robot is currently connected to, an alert will appear on the Android application, notifying the user that the Wi-Fi Seeker has completed its task, and stating the value of the signal strength at that location. A mockup of what the alert will look like is shown in Figure 4.4.E below. This alert will appear on top of the Main Activity.

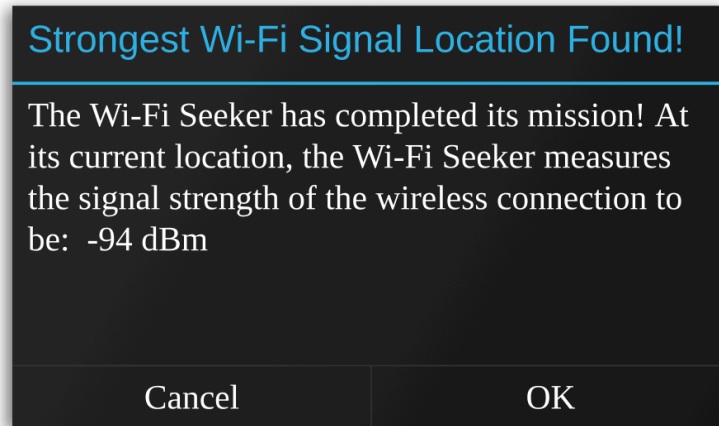

Figure 4.4.E - Android Alert for Notification of Algorithm Completion

The Android application for the Wi-Fi Seeker is fairly direct. In Figure 4.4.F below is an activity diagram for the application. It depicts how the user will use the Android application from launch to exit.

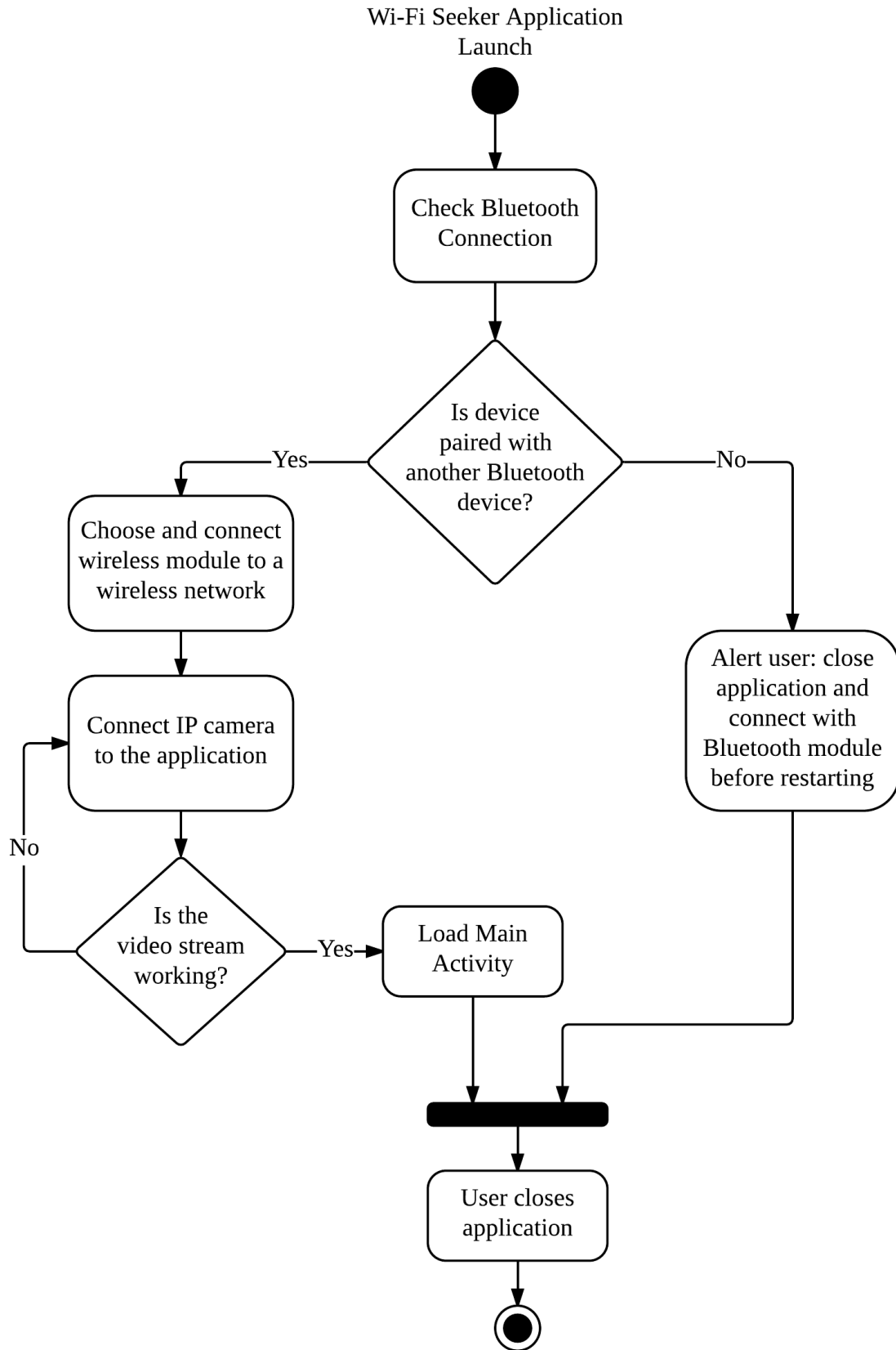

Figure 4.4.F - Android Application State Diagram

4.5 Wireless Subsystem

The wireless subsystem is in reference to the two specific wireless applications that will be used by the Wi-Fi Seeker. First there is the wireless communication that will take place between the Android application and the Wi-Fi Seeker robot itself, for which Bluetooth will be used. While Bluetooth comes integrated with all Android devices, a Bluetooth module will need to be added to the MSP430F5529 in order to give the robot Bluetooth capabilities. Second the robot will need to be able to connect to a Wi-Fi network in order to be able to sense the strength of a wireless network. This means that a wireless module will also need to be connected to the MSP430F5529 in order for the wireless signal sensing to be possible.

4.5.1 Bluetooth Communication

In order for the Android device to communicate with the MSP430F5529 using Bluetooth, the device must establish a connection with the Bluetooth module that is connected to the MSP430F5529. Since all Android devices have Bluetooth capability, the native Android software will be used to connect to the Bluetooth module. When the Bluetooth module is turned on, it is put into "discoverable mode", which means that it is available for pairing. At this point the user will use the Android device's operating system to find and select the Bluetooth module to pair with. In order to maintain a secure connection, there will be a pin that needs to be entered by the user on the Android device in order to connect with the Bluetooth module. Once the user's Android device is paired with the Bluetooth module, no other devices will be able to connect to the Bluetooth module.

Once the user has successfully connected to the Wi-Fi Seeker robot using Bluetooth, the user will be able to communicate with the robot. The very first thing that the user must do after connecting to the robot via Bluetooth is to establish the connection to a Wi-Fi network for the wireless module. In order to do this, the user should open up the Android application and follow the initial setup that will allow the user to connect to a wireless network. As the user does this on the Android application, the data will be sent via Bluetooth to the MSP430F5529 microcontroller, which will then relay the information to the wireless module. Once the wireless module is initialized and connected to a wireless network, the Wi-Fi Seeker will be functional.

After the initial setup is completed and the Wi-Fi Seeker robot is officially operational, the initial mode of operation that the Wi-Fi Seeker robot will be in will be referred to as "manual mode". This is because the Android application will be displaying the manual controls that will allow the user to control the motion of the robot. Thus when the robot is in manual mode, the user will be able to issue specific commands using the Android application, such as motion control commands, or the user can choose to start the autonomous functionality of the Wi-Fi Seeker. Should the user issue a directional command by pushing one of the directional buttons in the Android application, the command will be sent to and executed by the robot. Should the user push the "Start Autonomous Mode" button, the Wi-Fi Seeker robot will begin its autonomous functionality. At this point the user will not be able to issue any commands to the robot; instead the user must wait for the robot to complete its mission before the robot and the Android application will revert back to manual mode. Once the robot has finished executing its algorithm, the user will be notified via an alert in the Android application. Once the alert has been received

both the Android application and the Wi-Fi Seeker robot will have reverted back to manual mode, and the user will be able to issue commands again. Even though the user will not be able to issue commands to the Wi-Fi Seeker robot during its autonomous mode, communication will still be taking place between the Android application and the robot, notably the current Wi-Fi signal strength value will be constantly be sent from the MSP430F5529 to the Android application. This is so that the user can note the progress that the Wi-Fi Seeker robot is making as it carries out its mission.

Figure 4.5.1.A shows the bidirectional communication that takes place between the Android application and the robot when the Wi-Fi Seeker is in manual mode. The user will be able to send commands for the robot using Bluetooth. The Bluetooth module will communicate with the MSP430F5529 in order to either make the robot move accordingly (directional command) or to start the autonomous functionality. The wireless module will be constantly sending the current wireless signal strength to the MSP430F5529, which will then relay the information back to the Android application through the Bluetooth module. Figure 4.5.1.B shows the unidirectional communication that takes place when the Wi-Fi Seeker is in autonomous mode. In autonomous mode the user will not be able to send commands to the robot, the user will only be able to receive data. The MSP430F5529 will be running the algorithm to determine the location where the wireless signal is strongest. The wireless module will be constantly sending the current wireless signal strength to the MSP430F5529 just as it was in manual mode, which is then send back to the Android application. Once the robot completes its mission, the Android application will be signaled and then both the robot and the Android application will revert back to manual mode.

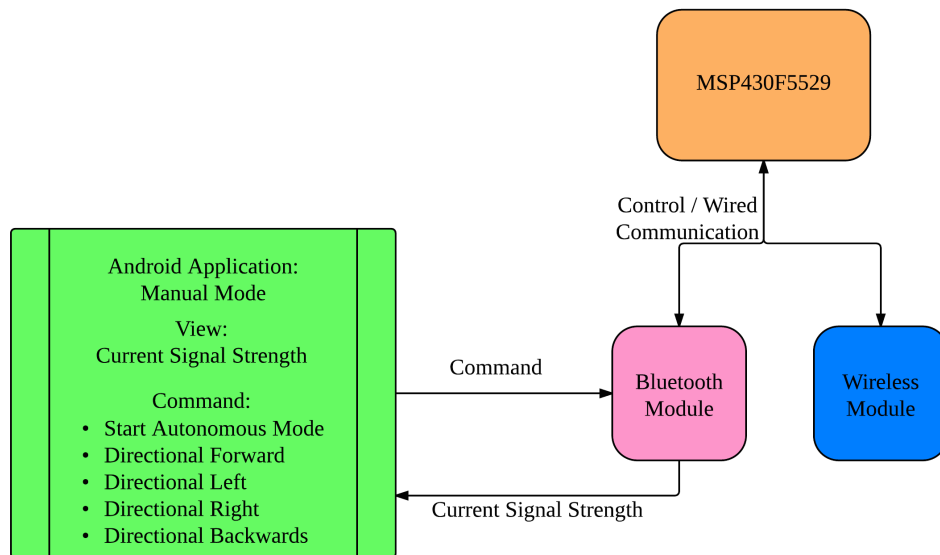

Figure 4.5.1.A - Manual Mode Wireless Communication

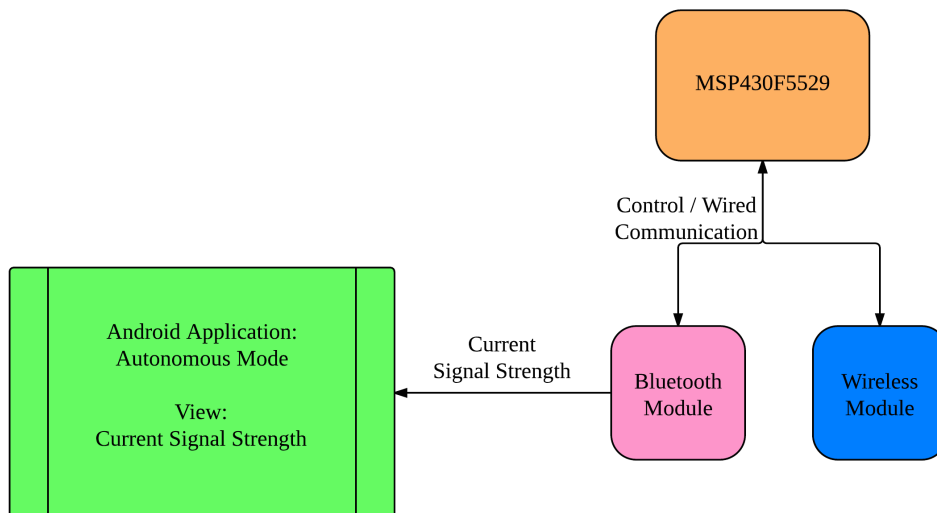

Figure 4.5.1.B - Autonomous Mode Wireless Communication

4.5.2 Wireless Signal Sensing

In order to determine the signal strength of the wireless network that the RN-XV WiFly module is connected to, the RSSI of the wireless signal will be measured and analyzed. There is a specific command "show rssi" that can be given to the WiFly module, which will return the value of the last received signal strength. The returned value will be in the form of a 2 character decimal value, which will be negative. According to the RN-XV WiFly module's Command Reference and User Guide, there is a threshold value for the RSSI, where if the RSSI falls below the threshold the module will disconnect from the wireless network it is currently connected to. This threshold value can be set by the user, but the document recommends a value between -50 and -80. This is because as the RSSI value nears -50 dBm the chances of the connection to the wireless access point breaking increases exponentially. The documentation for the WiFly module does not specify what the minimum or maximum values are that could be returned by the "show rssi" command. As a result, before the final algorithm is developed for the Wi-Fi Seeker the WiFly module will be tested to determine an acceptable value for the RSSI threshold, or the minimum value for the "show rssi" command. Additionally, in order to determine an average maximum RSSI value that can be incorporated into the final algorithm, an average will be taken of the results of measuring the RSSI value when the module is within a third of a meter to the wireless access point that broadcasts the wireless signal that the WiFly module is connected to.

4.6 Video Streaming Subsystem

The video feed that will be sent from the Wi-Fi Seeker robot to the Android application will be its own subsystem. This is because the amount of data required to wirelessly transmit a video stream would be extremely challenging to accomplish using the MSP430F5529 microcontroller. Instead of upgrading the main controller on the robot to a system-on-chip, it was instead decided to separate the video stream from the other wireless communications. Figure 4.6.A below depicts how the video streaming subsystem will work. Both the Android device and the IP camera will connect to the same wireless access point. After this initial connection is made, the Android

application will be able to directly access the video feed from the IP camera by using its unique IP address. Once the Android application is connected to the camera, the video stream can be wirelessly transmitted and then displayed within the Android application as long as both devices remain connected to the Internet.

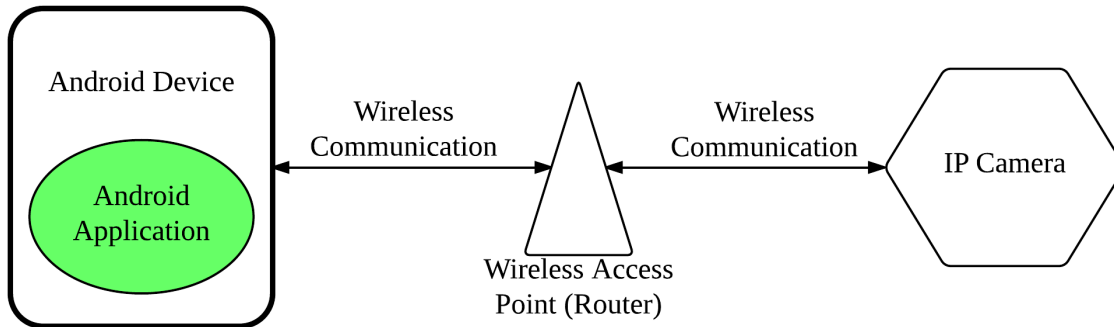

Figure 4.6.A

In order to achieve this, an IP camera will be used, specifically the D-Link DCS-932L Wireless Network Camera. First, the camera needs to connect to the Internet. There are several different ways to do this initial setup. The simplest method is to push the WPS button on the camera and on the wireless router within 60 seconds of each other, and the camera should automatically connect. After the camera is connected to the same wireless network that the Android device is, the next step is to connect the two devices directly. Once properly set up the D-Link DCS-932L will be assigned an IP address. Using the Android application the specific IP address will be used, allowing the application to directly access the video stream. After the connection is made the application will be able to stream the video being sent from the IP camera as long as both devices remain connected to the Internet.

4.7 Power Subsystem

The diagram in Figure 4.7.A below depicts how every component for the Wi-Fi Seeker robot will be supplied power. The solar panel will supply energy to the batteries through a maximum power point tracking charging controller, which will charge the batteries. The main power supply will be a 7.4 V battery, which will connect to the motor controllers and two voltage regulators. One of the regulators will be a 5 V regulator that will power the webcam, IR proximity sensors, and ultrasonic sensors. These components will be connected to this regulator because they all need 5 V to operate. The 3.3 V regulator will connect to the microcontroller, Bluetooth module, and the Wi-Fi module. These components will be connected to this regulator because they all require 3.3 V to operate. The motor controllers will be directly connected to the battery. They do not require voltage regulators since they can support voltages from 2 to 7.5 V. Since the 7.4 V provided by the battery is within the range of the voltage needed for the motor controllers, the group decided to save money by not attaching a voltage regulator for these components.

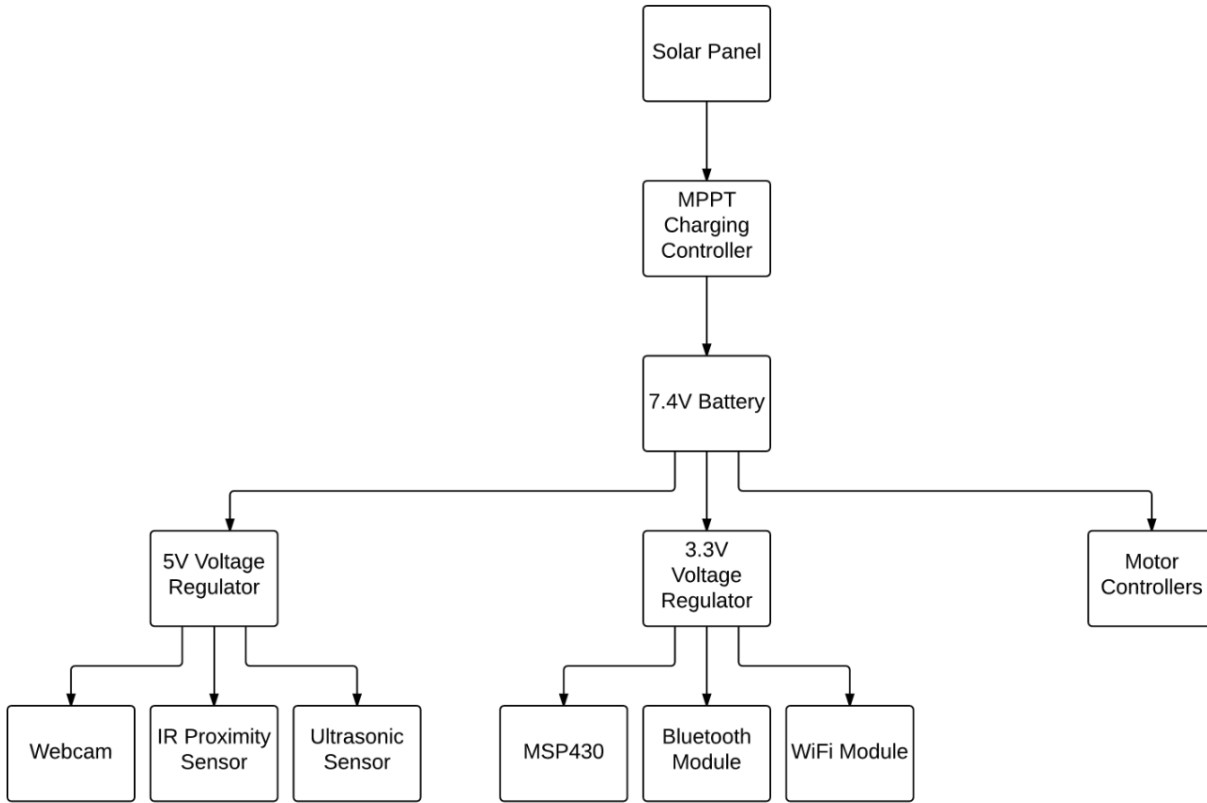

Figure 4.7.A

4.7.1 Rechargeable Batteries

The rechargeable batteries will power all of the components for the robot. They will be connected through all of the components via a physical switch. The switch is in place as a power on or power off state. When the robot needs to be used, the switch can be flipped to the ON position. When the robot is finished being used, the switch can be flipped to the OFF position. The switch helps to prevent energy from being leached by the components when not in use. If the switch were not there, the battery would drain slowly while the robot is not used. When the switch is closed, a maximum current of 28A will flow to node A, where it will split into 3 subsystems. These three subsystems will be for the components that operate at different voltages. This design is illustrated below in Figure 4.7.1.A.

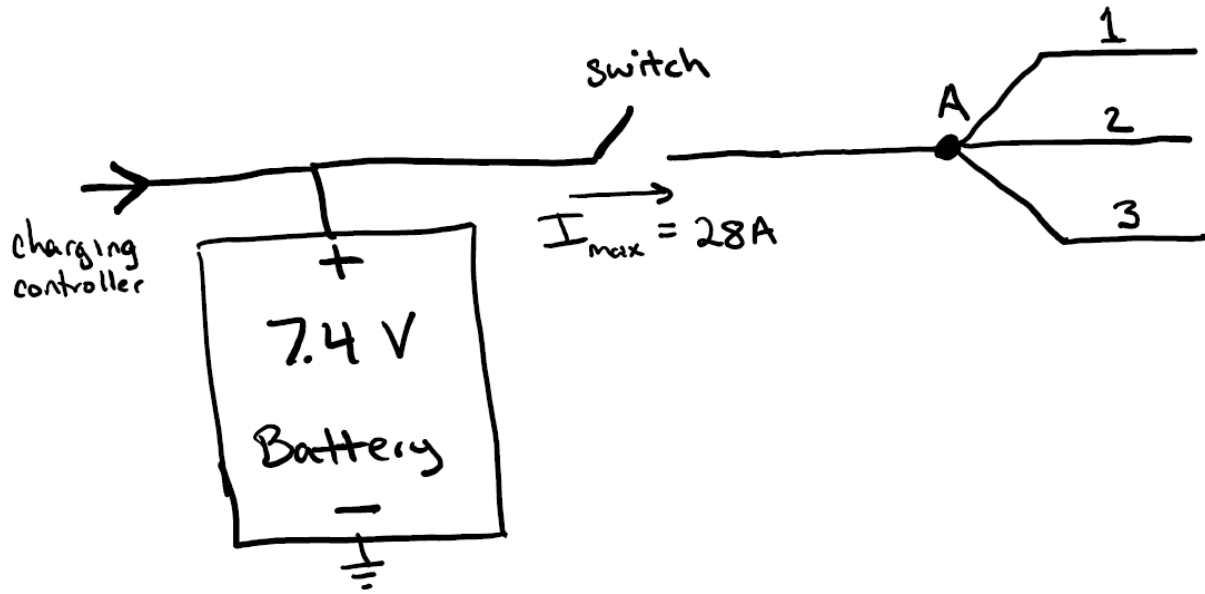

Figure 4.7.1.A – Splitting the Power into Three Subsystems

The first subsystem, represented by line number 1, will connect to the 5 V voltage regulator. From the regulator, the infrared sensor, proximity sensor, and webcam will be connected to the output. They will be powered by 5 V and each component will receive its required current. This design is illustrated below in Figure 4.7.1.B.

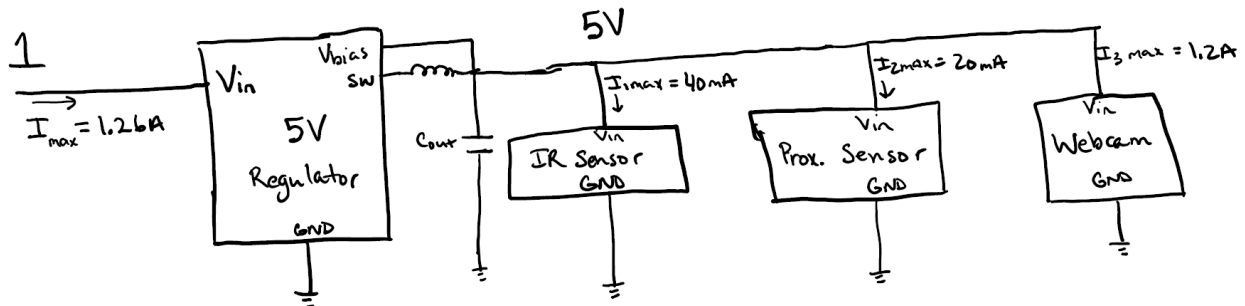

Figure 4.7.1.B – Subsystem 1 (5V)

The second subsystem, represented by line number 2, will connect to the 3.3 V voltage regulator. From the regulator, the MSP430, Bluetooth module, and Wi-Fi module will be connected to the output. They will be powered by 3.3 V and each component will receive its required current. The design is illustrated below in Figure 4.7.1.C.

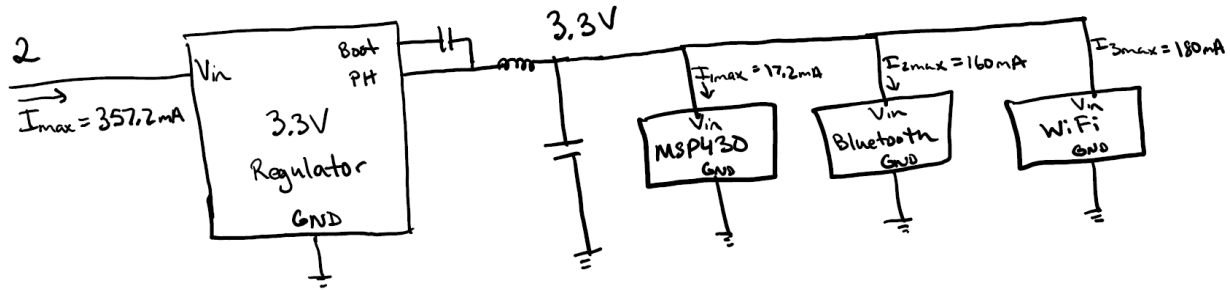

Figure 4.7.1.C – Subsystem 2 (3.3V)

The third subsystem, represented by line number 3, will directly connect the battery to the motor controllers. This means that the motor controllers will be powered by 7.4 V and will receive the required current. The design is illustrated below in Figure 4.7.1.D.

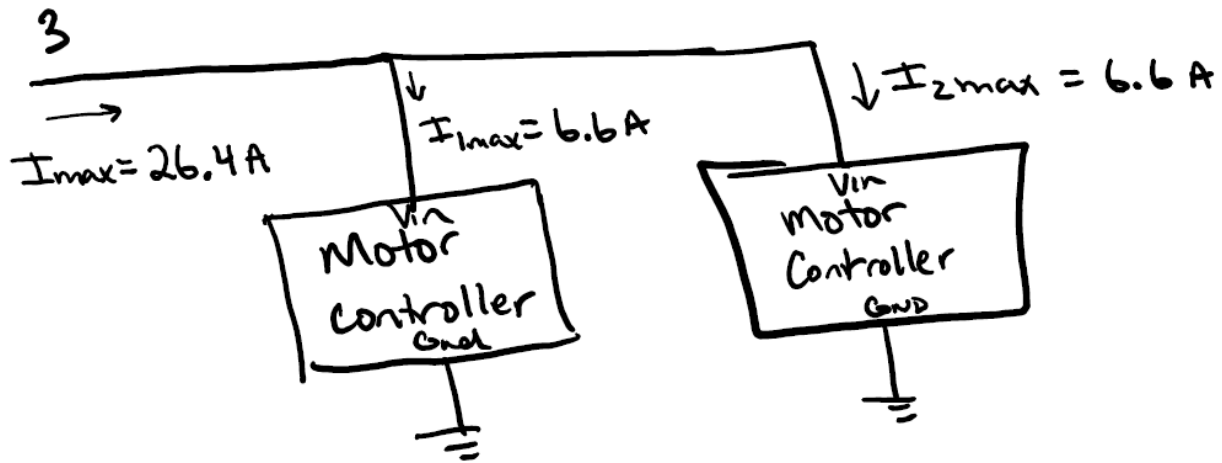

Figure 4.7.1.D – Subsystem 3 (Motor Controllers)

4.7.2 Solar Panel

The solar panel will produce the energy required to recharge the battery. It will be connected through the maximum power point tracker to the Vcc pin. The tracker will maintain the solar panel at its maximum power efficiency. The charging controller will be connected to the 7.4 volt battery. This design will continuously charge the battery until it is fully charged. When it is charging, a red LED will illuminate. When the battery is fully charged, the green LED will illuminate. The design is illustrated below in Figure 4.7.2.A.

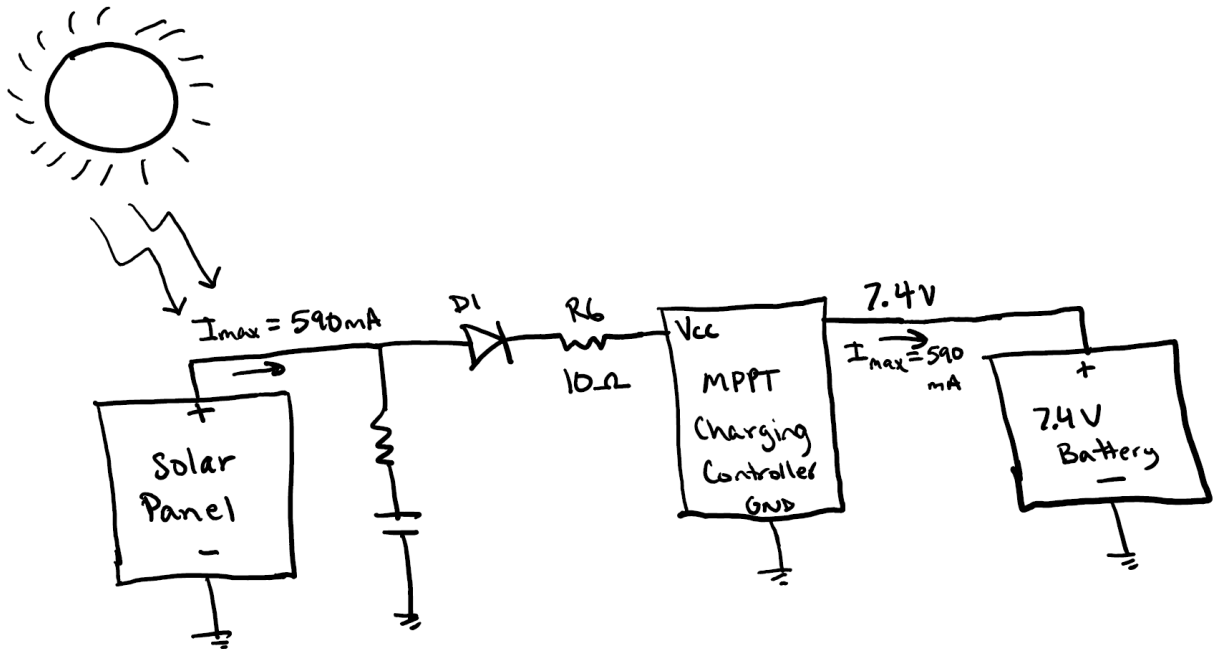

Figure 4.7.2.A – Connecting the Solar Panel to the Charge Controller and Battery

4.7.3 MTTP Charge Controller

The charge controller will be designed using Texas Instruments’ reference design, as shown below in Figure 4.7.3.A.

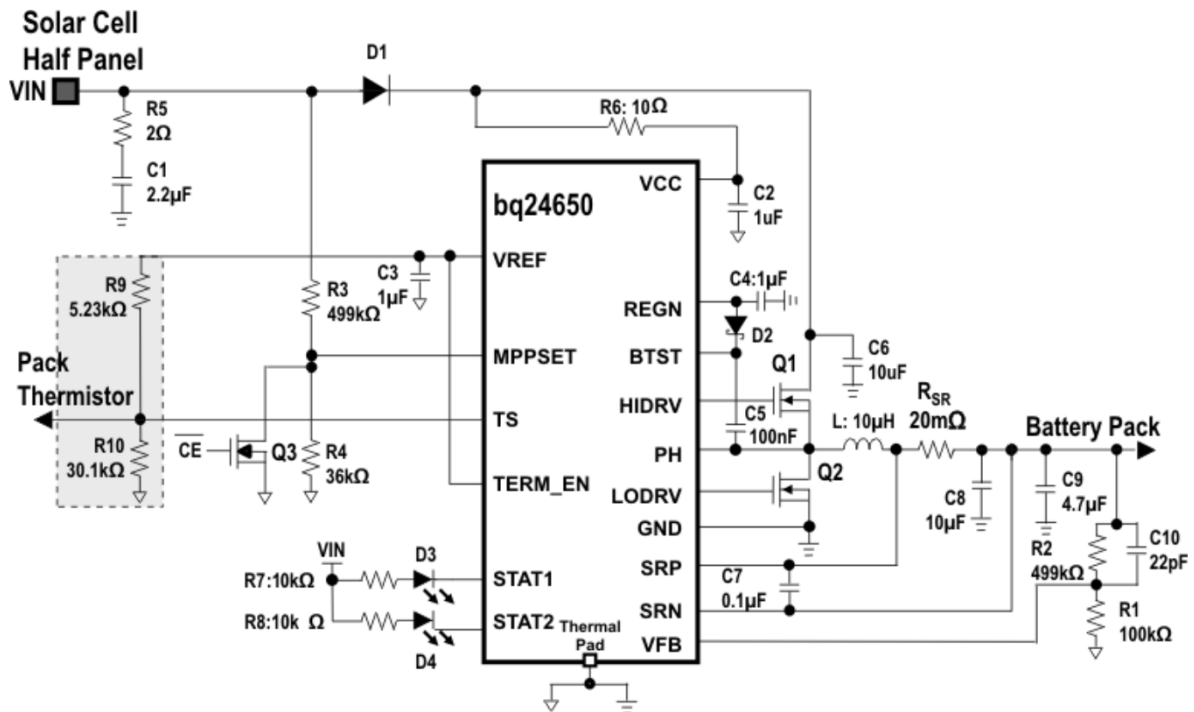

Figure 4.7.3.A - Texas Instruments’ Charge Controller Reference Circuit

The voltage at which the battery needs to be charged will be set by the resistor divider between R1 and R2, and can be calculated using the following equation:

$$V_{\text{BAT}} = 2.1 \text{ V} \times \left[1 + \frac{R2}{R1} \right]$$

Since the voltage of the battery we are going to be using is 7.4 volts, which will be Vbat. The resistor R2 can be found by letting R1 equal 100k ohms. From the equation, R2 is found to be 252.3k ohms.

The maximum power point tracking input voltage regulation from the solar panel will be set by the resistor divider between R3 and R4 will be set using the following equation:

$$V_{\text{MPPSET}} = 1.2 \text{ V} \times \left[1 + \frac{R3}{R4} \right]$$

The solar panel that is going to be used has its maximum power output at 17.3 volts, which will be Vmppset. The resistor R3 can be found by letting R4 equal 35k ohms. Using the equation, R3 is found to be 469.5k ohms.

The battery charging current regulation will be set by changing Rsr using the following equation:

$$I_{\text{CHARGE}} = \frac{40 \text{ mV}}{R_{\text{SR}}}$$

The battery that will be used has a capacity of 3000 mAh. It is recommended to charge at 1C, which will be 3 A (multicopter). Solving for Rsr, it is found that Rsr is equal to 13.3 milli-ohms.

The pre-conditioning current regulation will be at (1/10) C set by Rsr chosen using the following equation:

$$I_{\text{PRECHARGE}} = \frac{4 \text{ mV}}{R_{\text{SR}}}$$

Since the battery will be charged at 3 A, the pre-conditioning current will be set to 10 percent of that. Therefore, it will be charging at 300 mA. This is when Rsr is constant at 13.3 milli-ohms.

The charging termination current will be at (1/10) C set by the Rsr chosen using the following equation:

$$I_{\text{TERM}} = \frac{4 \text{ mV}}{R_{\text{SR}}}$$

Similarly, the charging current termination will be at 10% of the charging current of 3 A. It will also terminate at 0.3 A. This is when Rsr is constant at 13.3 milli-ohms.

It is advised to operate the battery within a temperature range of -20 to 60 degrees Celsius (ib-power). This circuit has the ability to monitor temperature from the battery pack's thermistor. However, it is unclear if the battery that will be used has one. If it does not have one, Texas Instruments recommends setting resistors R9 and R10 to 100k ohms. When the battery arrives, the resistors will be calculated if it has a thermistor. For overheating protection of the battery, the

boundaries at which it will charge will be between temperatures of -20 and 60 degrees Celsius. This boundary will be set using the following equations:

$$RT2 = \frac{V_{VREF} \times RTH_{COLD} \times RTH_{HOT} \times \left(\frac{1}{V_{LTF}} - \frac{1}{V_{TCO}} \right)}{RTH_{HOT} \times \left(\frac{V_{VREF}}{V_{TCO}} - 1 \right) - RTH_{COLD} \times \left(\frac{V_{VREF}}{V_{LTF}} - 1 \right)}$$

$$RT1 = \frac{\frac{V_{VREF}}{V_{LTF}} - 1}{\frac{1}{RT2} + \frac{1}{RTH_{COLD}}}$$

In Figure 4.7.3.B, the resistors will be connected as a voltage divider and the thermistor from the battery pack will be connected in parallel with RT2.

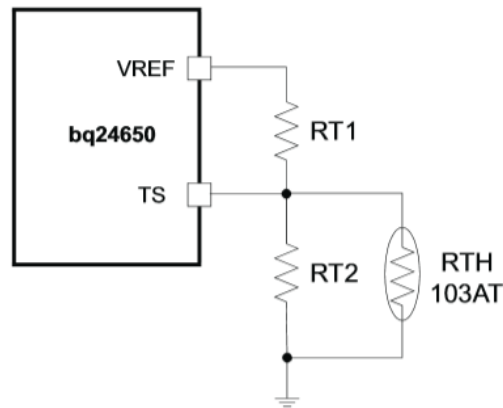

Figure 4.7.3.B

The bill of materials that is required for the charge controller circuit from Figure 4.7.3.A is shown in Table 4.7.3.A below. The parts and their prices were found on Digi-key.

Table 4.7.3.A – Bill of Materials for Charge Controller Circuit

Part	Description	Qty	Price
MPPT	Charge Controller: BQ24650RVAT, 296-27699-1-ND	1	\$5.96
Q1, Q2	N-channel MOSFET, 40 V, 10 A, PowerPAK SO-8, Vishay-Siliconix, Si7288	2	\$3.18
D2	Diode, Dual Schottky, 30 V, 200 mA, SOT23, Fairchild, BAT54C	1	\$0.20
D3, D4	LED Diode, Green, 2.1V, 20mA, LTST-C190GKT	2	\$0.56
Rsr	Sense Resistor, 13.3 mΩ, Vishay-Dale, WSL1206R0200DEA	1	\$0.61
L1	Inductor, 10 μH, 7A, Vishay-Dale IHLP-2525CZ	1	\$1.28
C6, C8	Capacitor, Ceramic, 10 μF, 35 V, 20%, X7R, 1210, Panasonic	2	\$1.54
C9	Capacitor, Ceramic, 4.7 μF, 35 V, 20%, X7R, 1210, Panasonic	1	\$0.70
C2, C3, C4	Capacitor, Ceramic, 1 μF, 35 V, 10%, X7R, 0805, Kemet	3	\$0.60
C5, C7	Capacitor, Ceramic, 0.1 μF, 35 V, 10%, X7R, 0805, Kemet	2	\$0.30
C1	Capacitor, Ceramic, 2.2 μF, 35V, 10%, X7R, 1210, Kemet	1	\$0.51

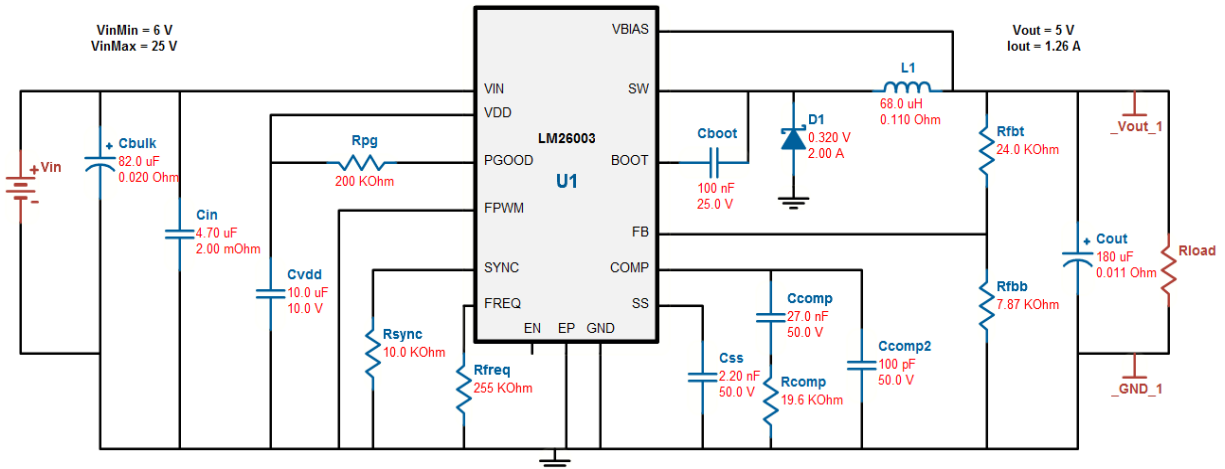

Figure 4.7.4.B – LM26003 Voltage Regulator Design

Since either of these regulators could be used for regulating voltage, in order to decide between them the advantages and disadvantages of each regulator were examined. The two factors that are of a concern are the efficiency and the footprint. A higher efficiency will help with battery life, because a higher efficiency means that less heat will be generated by the regulator, which in turn means less power will be consumed. A lower footprint will accommodate less space on the robot, which in turn will drive down the cost of the PCB. This is because the PCB manufacturers usually charge by the size of the board. Table 4.7.4.A below examines the tradeoff between the efficiency and footprint of the chosen two voltage regulators, assuming a PCB costs \$5 per square inch.

Table 4.7.4.A – Efficiency and Footprint of Potential 5V Voltage Regulators

Part Number	Efficiency	Footprint	Footprint	BOM Cost	PCB Cost	Total Cost
LM43602PWPR	95.2%	1169 mm ²	1.811 in ²	\$5.71	\$9.06	\$14.77
LM26003MHX/NOPB	91%	570 mm ²	0.8835 in ²	\$4.24	\$4.42	\$8.66

Table 4.7.4.B – Bill of Materials for LM26003 Circuit

Part	Manufacturer	Part Number	Quantity	Price
Cboot	MuRata	GRM21BR71E104KA01L	1	\$0.01
Cbulk	Panasonic	35SVPF82M	1	\$0.61
Ccomp	Yageo America	CC0805KRX7R9BB273	1	\$0.01
Cin	MuRata	GRM32ER71H475KA88L	1	\$0.31
Cout	Panasonic	16SVPE180M	1	\$0.49
Css	Yageo America	CC0805KRX7R9BB222	1	\$0.01
Cvdd	MuRata	GRM21BC81A106KE18L	1	\$0.03
D1	Toshiba	CMS06	1	\$0.19
L1	Bourns	SRR1260-680M	1	\$0.41
Rcomp	Panasonic	ERJ-6ENF1962V	1	\$0.01
Rfbb	Panasonic	ERJ-6ENF7871V	1	\$0.01
Rfbt	Susumu Co Ltd	RR1220P-243-D	1	\$0.01

Rfreq	Panasonic	ERJ-6ENF2553V	1	\$0.01
Rpg	Panasonic	ERJ-6ENF2003V	1	\$0.01
Rsync	Panasonic	ERJ-6ENF1002V	1	\$0.01
U1	Texas Instruments	LM26003MHX/NOPB	1	\$2.10
Ccomp2	Yageo America	CC0805JRNP09BN101	1	\$0.01
			Total:	\$4.24

As shown in Table 4.7.4.A, the LM43602 has the higher efficiency but the footprint is about double of the LM26003. Additionally, the materials required in order to build the circuit for the LM43602 costs more. Since the footprint is larger, the cost of the PCB increases. Therefore the 5 V regulator that will be chosen for this project is the LM26003 since it has a marginal difference in efficiency and the footprint is much lower, resulting in a much cheaper implementation (about \$6). The bill of materials for the LM26003 can be seen in Table 4.7.4.B.

Choosing the 3.3V Voltage Regulator: The 3.3 V regulators must be chosen for the microcontroller, Bluetooth module, and the Wi-Fi module such that these components will be provided with the correct operating voltage. The regulator was also found using the TI's Webench Power Architect. The minimum input voltage was kept the same at 6 volts, and the maximum input voltage was also kept the same at 25 volts. After filtering the regulators by the highest efficiency, the two regulators that were chosen for comparison were the TPS54335DDAR and the TPS54336DDAR. The TPS54335DDAR circuit design is shown in Figure 4.7.4.C below, and the circuit design for the TPS54336DDAR is shown in Figure 4.7.4.D. Just as there were concerns when choosing the 5 V regulator, the same concerns about the efficiency and footprint are considered when choosing the 3 V regulator. A comparison of the two regulators are shown below in Table 4.7.4.C.

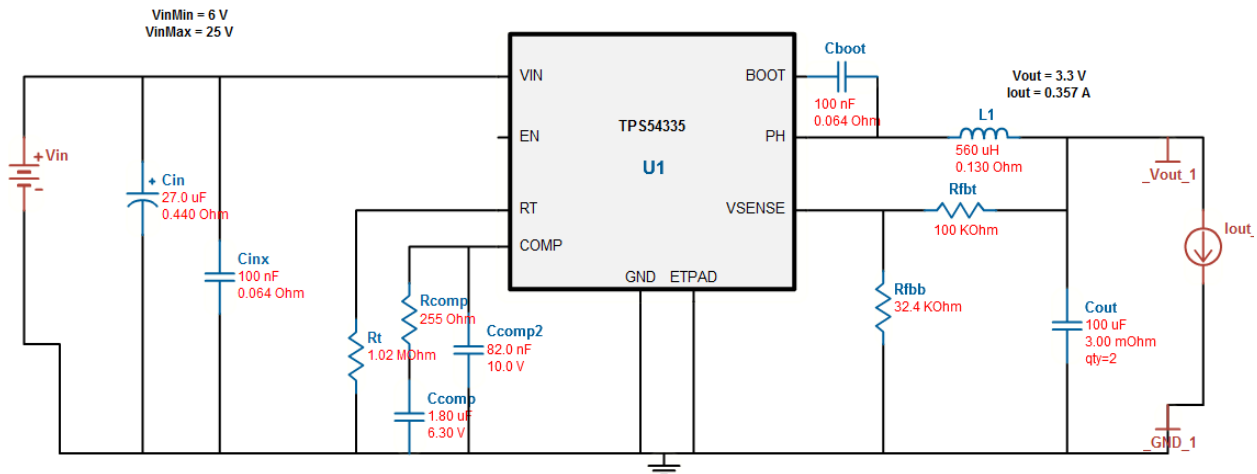

Figure 4.7.4.C - TPS54335DDAR Voltage Regulator Design

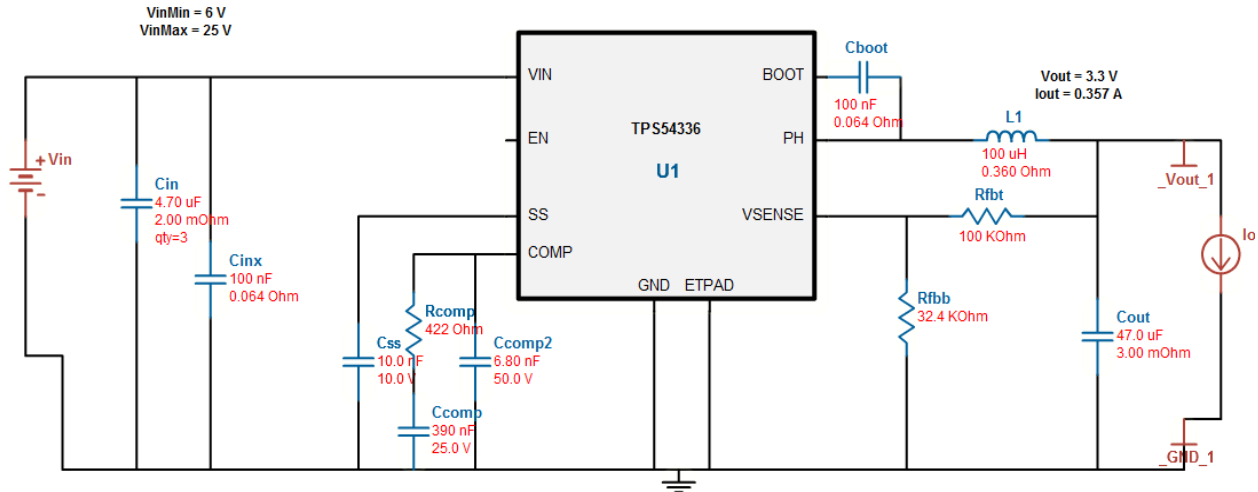

Figure 4.7.4.D - TPS54336DDAR Voltage Regulator Design

Table 4.7.4.C – Efficiency and Footprint of Potential 3.3V Voltage Regulators

Part Number	Efficiency	Footprint	Footprint	BOM Cost	PCB Cost	Total Cost
TPS54335DDAR	95.1%	1096 mm ²	1.698 in ²	\$2.89	\$8.49	\$11.38
TPS54336DDAR	86.3%	227 mm ²	0.3518 in ²	\$2.38	\$1.76	\$4.14

Table 4.7.4.D – Bill of Materials for TPS54336 Circuit

Part	Manufacturer	Part Number	Quantity	Price
Cboot	Kemet	C0805C104K5RACTU	1	\$0.01
Ccomp	MuRata	GRM21BR71E394KA01L	1	\$0.08
Ccomp2	Yageo America	CC0805KRX7R9BB682	1	\$0.01
Cin	MuRata	GRM32ER71H475KA88L	3	\$0.31
Cinx	Kemet	C0805C104K5RACTU	1	\$0.01
Cout	MuRata	GRM31CR60J476ME19L	1	\$0.12
Css	MuRata	GRM033R61A103KA01D	1	\$0.01
L1	Panasonic	ELL-6UH101M	1	\$0.28
Rcomp	Vishay-Dale	CRCW0805422RFKEA	1	\$0.01
Rfbb	Panasonic	ERJ-6ENF3242V	1	\$0.01
Rfbb	Panasonic	ERJ-6ENF1003V	1	\$0.01
U1	Texas Instruments	TPS54336DDAR	1	\$0.90
			Total:	\$2.38

As shown in Table 4.7.4.C, the TPS54335 has a higher level of efficiency. It's about 9% more efficient than the TPS54336. As for the cost of the materials necessary to build each circuit, the costs for both parts are almost identical. However, the TPS54336 has a significantly smaller footprint. Since the footprint is so low for the TPS54336, the PCB costs about 7 dollars less. Considering the small decrease in efficiency in return for an extremely reduced footprint, it was decided to choose the TPS54336 to be 3.3 V voltage regulator chosen for the Wi-Fi Seeker robot. The bill of materials for the TPS54336 is listed in Table 4.7.4.D.

5.0 Design Summary of Hardware and Software

5.1 Hardware

5.1.1 Specifications

The Wi-Fi Seeker robot will meet all of the following:

- The robot will have motors that will be controlled by the microcontroller.
- The robot will have sensors to assist in obstacle avoidance.
- The robot will be powered by lithium polymer batteries.
- The robot will have a solar cell that will be used to recharge the lithium polymer batteries.

5.1.2 Microcontroller

The Wi-Fi Seeker robot will be equipped with Texas Instruments' MSP430F5529 microcontroller, which will be responsible for the autonomous functionality of the robot. Additionally the microcontroller will be communicating with several different modules and devices via UART and SPI, making it the backbone of this project.

Table 5.1.2.A - MSP430F5529 Specifications

Specification	Value
Flash Memory	128 KB
RAM	8 KB
CPU Frequency	25 MHz
Architecture	16-bit RISC
I/O	UART – 2 I ² C – 2 SPI – up to 4
Operating Voltage	1.8 - 3.6 V
Active Mode Current	0.26mA at 3.0V for Flash program execution 0.15mA at 3.0V for RAM program execution
Off Mode	1.1µA at 3.0V
Shutdown Mode	0.18µA at 3.0V
Pin Count	63
Price	\$3.58

5.1.3 Bluetooth Module

The Bluetooth module will be used to give the Wi-Fi Seeker robot the capability to communicate with the Android device via Bluetooth. The specific Bluetooth module for the Wi-Fi Seeker will be the RN41-XV Bluetooth Module. In order to establish power to the Bluetooth module, pin 1 must be connected to a 3.3V regulated power source and pin 10 must be grounded. As for the actual communication, pin 3 on the Bluetooth module is for UART_RX and pin 2 is for

UART_TX. These I/O pins must be connected to corresponding UART pins on the MSP430F5529 microcontroller, which will be pin 40 (UART TX) and pin 41 (UART RX) respectively. Additionally, the Bluetooth module has pins 12 and 16 reserved for UART Request To Send (RTS) and Clear To Send (CTS). Since the Wi-Fi Seeker will not be using a TCP/IP protocol, these pins will be grounded to allow the MSP430F5529 and the Bluetooth module to communicate freely. After connecting these pins accordingly serial communication will be able to take place between the Bluetooth Module and the MSP430F5529 microcontroller.

Table 5.1.3.A - RN41-XV Bluetooth Module Specifications

Specification	Value
Typical Operating Voltage	3.3 V
Minimum Voltage	3.0 V
Maximum Voltage	3.6 V
Typical RX Current	35mA
Maximum RX Current	60mA
Typical TX Current	65mA
Maximum TX Current	100mA
Standby Current	25mA
Sleep Current	2.5mA
I/O	UART
Transmission Rate	up to 3.0 Mbps
Price	\$29.95

5.1.4 Wireless Module

The wireless module will be used to give the Wi-Fi Seeker robot the capability to connect to a Wi-Fi signal that it will then analyze in order to sniff out the location where the signal is strongest. The specific wireless module for the Wi-Fi Seeker will be the RN-XV WiFly Module. In order to establish power to the WiFly Module, pin 1 must be connected to a 3.3V DC power source and pin 10 must be grounded. As for the actual communication, pin 2 on the WiFly Module is for UART_TX and pin 3 is for UART_RX. These I/O pins must be connected to corresponding pins on the MSP430F5529 microcontroller, which would be pin 52 (UART RX) and pin 51 (UART TX) respectively. Additionally, the WiFly module has pins 12 and 16 reserved for UART Request To Send (RTS) and Clear To Send (CTS). Since the Wi-Fi Seeker will not be using a TCP/IP protocol, these pins will be grounded to allow the MSP430F5529 and the WiFly module to communicate freely. This will allow for serial communication to take place between the WiFly Module and the MSP430F5529 microcontroller.

Table 5.1.4.A - RN-XV WiFly Module Specifications

Specification	Value
Typical Operating Voltage	3.3 V
Minimum Voltage	3.0 V
Maximum Voltage	3.7 V
RX Current	40mA
TX Current	180mA
Standby Current	15mA
Sleep Current	4 μ A
I/O	8 general purpose digital I/O pins
Communication Protocol	TCP/IP
Transmission Rate	1-11 Mbps for 802.11b 6-54 Mbps for 802.11g
Price	\$34.95

5.1.5 Camera

The IP camera selected was the D-Link DCS-932L. Since this is an IP camera, the only device that the camera will be communicating with is the Android device itself, bypassing the microcontroller altogether. Therefore the only physical connection that will be made to the IP camera is for the power. All data communications will be wireless.

Table 5.1.5.A - D-Link DCS-932L Specifications

Specification	Value
Flash Memory	4 MB
SD RAM	32 MB
Operating Voltage	5 V
Operating Current	1.2 A
Maximum Power Consumption	4.5 W
Wireless Connectivity	802.11 b/g/n
Resolution	640x480 at 20 fps 320x240 at 30 fps
Video Codec	MJPEG
Operating Temperature	32°F - 140°F
Price	\$53.24

5.1.6 Sensors

With the information noted in the research section, it was decided to use both infrared sensors and ultrasonic sensors in order to give the Wi-Fi Seeker robot the best chance to be functional in all possible scenarios. There will be one of each sensor mounted on the front and rear of the Wi-Fi Seeker robot for a total of four sensors. They will be attached to the MSP430F5529 microcontroller, and provide an analog signal to relay information of obstacles in range.

Table 5.1.6.A – Ultrasonic Sensor Specifications

Specification	Value
Part Number	HC-SR04
Detection Range	2-500 cm
Operating Voltage	5V
Operating Current	2mA
Measuring Angle	15 degrees
Price	\$3.99

The specific ultrasonic sensor that will be connected to the robot will be the HC-SR04. This device has four pins out of the module: a GND, Echo pulse output, Trig pulse input, and Vcc. The process of the sensor is as follows: pull the Trig pin to a high level for more than 10 microsecond impulse, the module start/finish ranging, if an object is in front, Echo pin will be high level. Based on the different duration of high level it will calculate the distance. It also has a measuring angle of fifteen degrees. This means that not only will objects directly in front of the sensor will be detected but also those in between the fifteen degrees trigger signal.

$$\text{Distance} = ((\text{Duration of high level}) * (\text{Sonic: } 340\text{m/s})) / 2$$

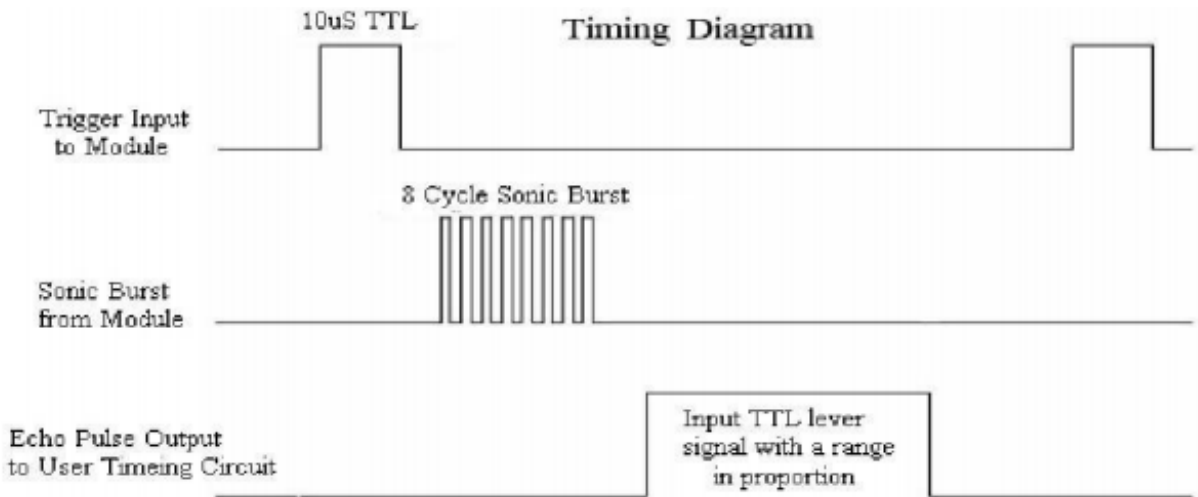

Figure 5.1.6.A - HC-SR04 Timing Diagram

In order to establish power to the HC-SR04 Ultrasonic sensor, Vcc will be connected to a 5V DC power source and the GND pin will be grounded. The first Ultrasonic sensor will have its Trig and Echo pins connected to pins 29 and 30, respectively, on the MSP430F5529 microcontroller. The second Ultrasonic sensor will have its Trig and Echo pins connected to pins 33 and 34 on the MSP430F5529 microcontroller, respectively.

Table 5.1.6.B – Infrared Sensor Specifications

Specification	Value
Part Number	GP2Y0A21YK
Detection Range	10-80 cm
Operating Voltage	4.5-5.5V
Operating Current	2mA
Measuring Angle	15 degrees
Price	\$13.95

The Wi-Fi Seeker robot will also be equipped with the Sharp GP2Y0A21YK infrared proximity sensor. It has three pins: Vo, GND, and Vcc. The last thing that was examined was the update time for the distance reading. Looking at the timing diagram for the sensor (Figure 5.1.6.B) the reading will be updated about every forty milliseconds, which is fast enough for the Wi-Fi Seeker robot's application.

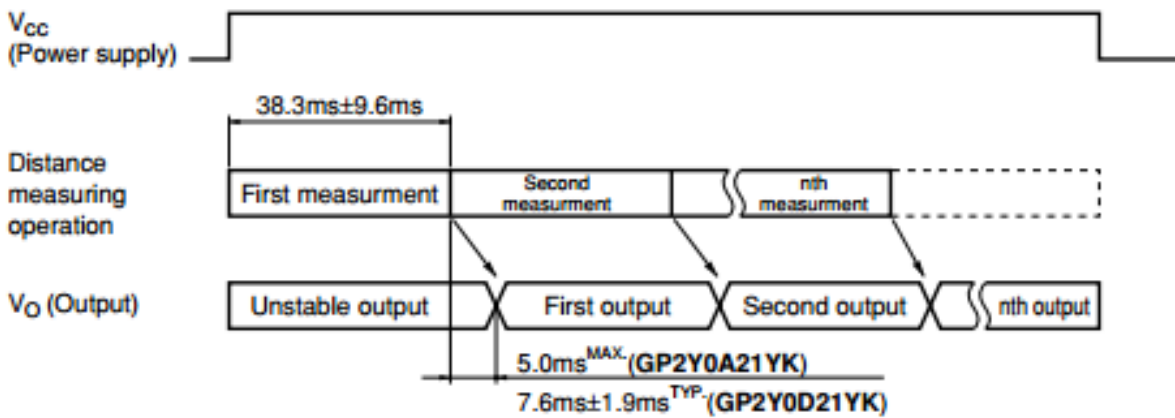

Figure 5.1.6.B - Sharp GP2Y0A21YK Timing Diagram

In order to establish power to the Sharp GP2Y0A21YK infrared proximity sensor, Vcc will be connected to a 5V DC power supply and GND will be connected to ground. The first infrared proximity sensor will have its Vo connected to pin 1 of the MSP430F5529 microcontroller. The second infrared proximity sensor will have its Vo connected to pin 2.

5.1.7 Motor

The motors that will be used come with the Wild Thumper 4WD 34:1 robot chassis. These motors will be powerful enough for the needs of the Wi-Fi Seeker, therefore there is no need to purchase or change the motors that the robot body comes equipped with. However, the circuitry will be redone such that the previously designed H-bridge will control the motors instead of whatever electronics come with the robot chassis. In order to establish power to the DC motors a 7.4V DC power source will be supplied.

Table 5.1.7.A - Motor Specifications

Specification	Value
Recommended motor voltage	2-7.5 V
Stall Current at 7.2 V	6.6 A per motor
No-load Current at 7.2 V	420 mA per motor
No-load output shaft speed at 7.2 V	350 RPM
Stall torque at 7.2 V	5 kg-cm per motor
Gearbox	34:1
Weight	92 g
Length(with shaft)	68 mm
Diameter	25 mm
Shaft Diameter	4 mm
Shaft Length	10 mm

5.1.8 Solar Panel

The solar panel will serve as our source of renewable energy to keep the battery charged. The solar panel that will be used is the Solartech Power Inc. SPM010P. This solar panel was selected for the Wi-Fi Seeker robot because it is sufficient enough to charge the battery. At maximum power, it is able to supply 590 mA of current to the battery. Also, the solar panel isn't too heavy, so the robot chassis will be able to support the weight. The solar panel will connect to the battery through a maximum power point tracker. This will assist the solar panel to operate at its maximum power of 10 Watts. The maximum power point tracker feature is integrated into the lithium polymer charging controller. The charging controller will connect to the battery and ensure it is charged properly by a constant current to constant voltage methodology.

Table 5.1.8.A – Solar Panel Specifications

Specification	Value
Model Number	SPM010P
Maximum Power	10 W
Voltage at Pmax	17.3 V
Current at Pmax	0.59 A
Short-Circuit Voltage	21.8 V
Short-Circuit Current	0.64 A
Nominal Voltage	12 V
Efficiency	9.5 %
Weight	3.3 lb
Area	176.9 in ²
Crystal Structure	Polycrystalline

5.1.9 Power Supply

In order to power the robot, each subsystem's requirements need to be known. The components need to have the correct voltage applied to them, while supporting them with enough current. If

these conditions are not met, the subsystems can fail and possible cause damage to other components. The specifications will be found in each of the component's data sheets. The voltage and current requirements are listed below in Table 5.1.9.A to see what kind of power sources they need.

Table 5.1.9.A - Voltage and Current Requirements for All Wi-Fi Seeker Components

Component	Voltage Requirement	Current Requirement
Ultrasonic Sensor	4.5-5.5 V	10-20 mA
Infrared Proximity Sensor	4.5-5.5 V	30-40 mA
Motor Controller	7.2 V	26.4 A
Microcontroller	1.8-3.6 V	15.4-17.2 mA
Webcam	5V	1.2 A
Wi-Fi Module	3-3.7 V	15-180 mA
Bluetooth Module	3-3.6	35-160 mA

Using the maximum current requirements, the total amount of current that needs to be supplied to the entire robot will be equal to: 20 mA + 40 mA + 26.4 A + 17.2 mA + 1.2 A + 180 mA + 160 mA = 28 Amps. Using the typical voltage requirements, the sensors and webcam will need about 5V, the microcontroller and Wi-Fi module needs about 3.3V, and the motors need 7.2V.

5.1.10 Robot Base

The chassis chosen for the Wi-Fi Seeker robot was the Wild Thumper 4WD All-Terrain Chassis made by Dagu. This rugged chassis has independent suspension for each of its spiked 120mm-diameter wheels, which gives it exceptional traction over uneven terrain. This feature is needed since the robot needs to be capable of traversing both outdoor and indoor environments. It also has 2mm-thick anodized aluminum body with 10mm-pitch grid of 4mm holes, which allows for plenty of mounting options for all of the electrical components. It also comes with four DC motors with brass bushes and a 34:1 gearbox to drive the tires. When powered at 7.2 V the chassis can reach a top speed of approximately 7 km/h, which is desirable when you take into consideration that the average walking speed of an adult is 5 km/h. Also, assuming that the robot will not exceed a weight of twenty pounds, the motors will be powerful enough to achieve these speeds.

Table 5.1.10.A - Wild Thumper 4WD 34:1 Specifications

Specification	Value
Size	280x300x130mm
Weight	1.9 kg
Ground clearance	60mm (when lightly loaded)
Recommended motor voltage	2-7.5 V
Stall current at 7.2 V	6.6 A per motor
No-load current at 7.2 V	420 mA per motor
No-load output shaft speed at 7.2 V	350 RPM
Stall torque	5 kg-cm per motor



Figure 5.1.10.A - Dagu Wild Thumper 4WD All-Terrain Chassis
Pending permission from Pololu

5.1.11 MSP430F5529 Connections

Now that all the parts have been chosen for the Wi-Fi Seeker robot, the connections that each of the components will make to the microcontroller can be determined. Table 5.1.11.A below describes all of the connections that will be made to the MSP430F5529, including which pins and what they are for.

Component	MSP430F5529 Pin	Connection Type
IR Sensor 1: Output	1	General Purpose I/O
IR Sensor 2: Output	2	General Purpose I/O
H-Bridge	23	General Purpose Digital I/O
H-Bridge	24	General Purpose Digital I/O
H-Bridge	25	General Purpose Digital I/O
H-Bridge	26	General Purpose Digital I/O
Ultrasonic Sensor 1: Trig	29	General Purpose Digital I/O
Ultrasonic Sensor 1: Echo	30	General Purpose Digital I/O
Ultrasonic Sensor2: Trig	33	General Purpose Digital I/O
Ultrasonic Sensor 2: Echo	34	General Purpose Digital I/O
Bluetooth Module RX	40	UART TX
Bluetooth Module TX	41	UART RX
H-Bridge PWM	42	Timer
H-Bridge PWM	43	Timer
Wireless Module RX	51	UART TX
Wireless Module TX	52	UART RX

5.2 Software

5.2.1 Specifications

The Wi-Fi Seeker robot will meet all of the following:

- The robot will be able to autonomously determine the location where the wireless signal it is connected to is the strongest.
- The robot will be controlled using an Android application running on an Android device.
- The application will have a manual control mode.

5.2.2 Android Application

The Android application that will be used to control the Wi-Fi Seeker robot will have several responsibilities. It must handle the initial setup required in order to allow the robot be functional, and then it must handle the actual control of the robot while it is active. In order to do this, there will be separate activities for when the robot is being initialized and when the robot is active. These activities will be called the `InitialActivity` and the `MainActivity`, respectively. Considering that both of these activities will be sharing a lot of data, it makes sense to use a singleton. In order to do this, a new class `WFSApplication` will be created, which will be an extension of the `Application` class. With this new class, the `AndroidManifest.xml` will be modified such that when the application is launched an instance of the `WFSApplication` class will be created instead of creating an instance of the `Application` class. The importance here is that the `WFSApplication` class will have class members for data that needs to be shared between the `InitialActivity` and the `MainActivity`, such as the `VideoView` that contains the stream from the IP camera on the robot. By having these static instances inside the `WFSApplication` class, it is essentially guaranteed that only a single instance of these variables will be created, and through the use of public setter and getter methods these variables can be accessed regardless of which screen the user is currently viewing within the application. Figure 5.2.2.A details the initial UML Class Diagram that depicts how the Android application will be developed.

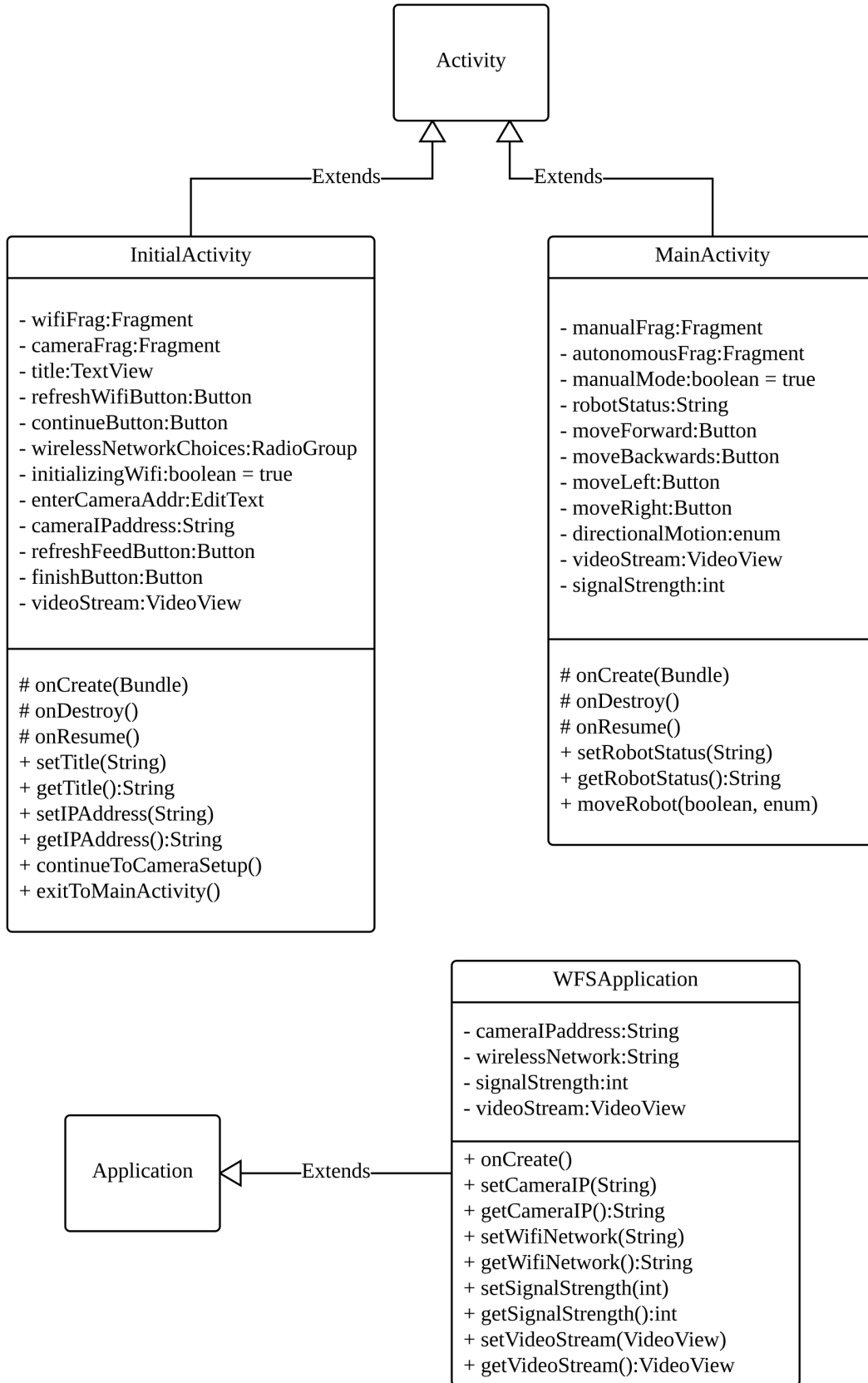

Figure 5.2.2.A - Android UML Class Diagram

5.2.3 Microcontroller

The code on the MSP430F5529 will be fairly complex, since after all the microcontroller is communicating with several different devices at once, notably the Bluetooth and WiFly modules, as well as the sensors and the motor control. The communication with the Bluetooth module will allow the microcontroller to talk with the Android application and receive commands or send data. The communication with the wireless module will allow the microcontroller to determine the strength of the wireless signal it is connected to. The communication with the sensors will tell the microcontroller whether or not it is safe to move in a specific direction. Finally the communication with the motor control will allow the microcontroller to move the robot in a number of different directions. Each of these individual communications are essential to the project, making the integration of them vital in order for the Wi-Fi Seeker robot to be operational.

The Bluetooth module will always be in communication with the MSP430F5529, since that is how the Android application will command the robot. As stated before there will be two major modes of operation: manual and autonomous modes. Manual mode will be the main method of the code, so to speak. In manual mode, the MSP430F5529 will be constantly listening for a command from the Android device. As soon as a command is given, the microcontroller will execute it. In the case of a motion command, the microcontroller will communicate with the sensors and then the motor control to move in the specified direction as long as there are no obstacles in the way. The other command that could be given is the command to begin the autonomous functionality. The MSP430F5529 would then execute a subroutine where the robot uses the RSSI command on the wireless module in conjunction with its algorithm to determine the location where the wireless signal is strongest. Since this autonomous functionality requires movement, there will also be communication with the sensors and the motor control. At the end of the algorithm, the autonomous mode exits and the manual mode code is resumed. Figure 5.2.3.A shows a visual representation of this process in a state diagram.

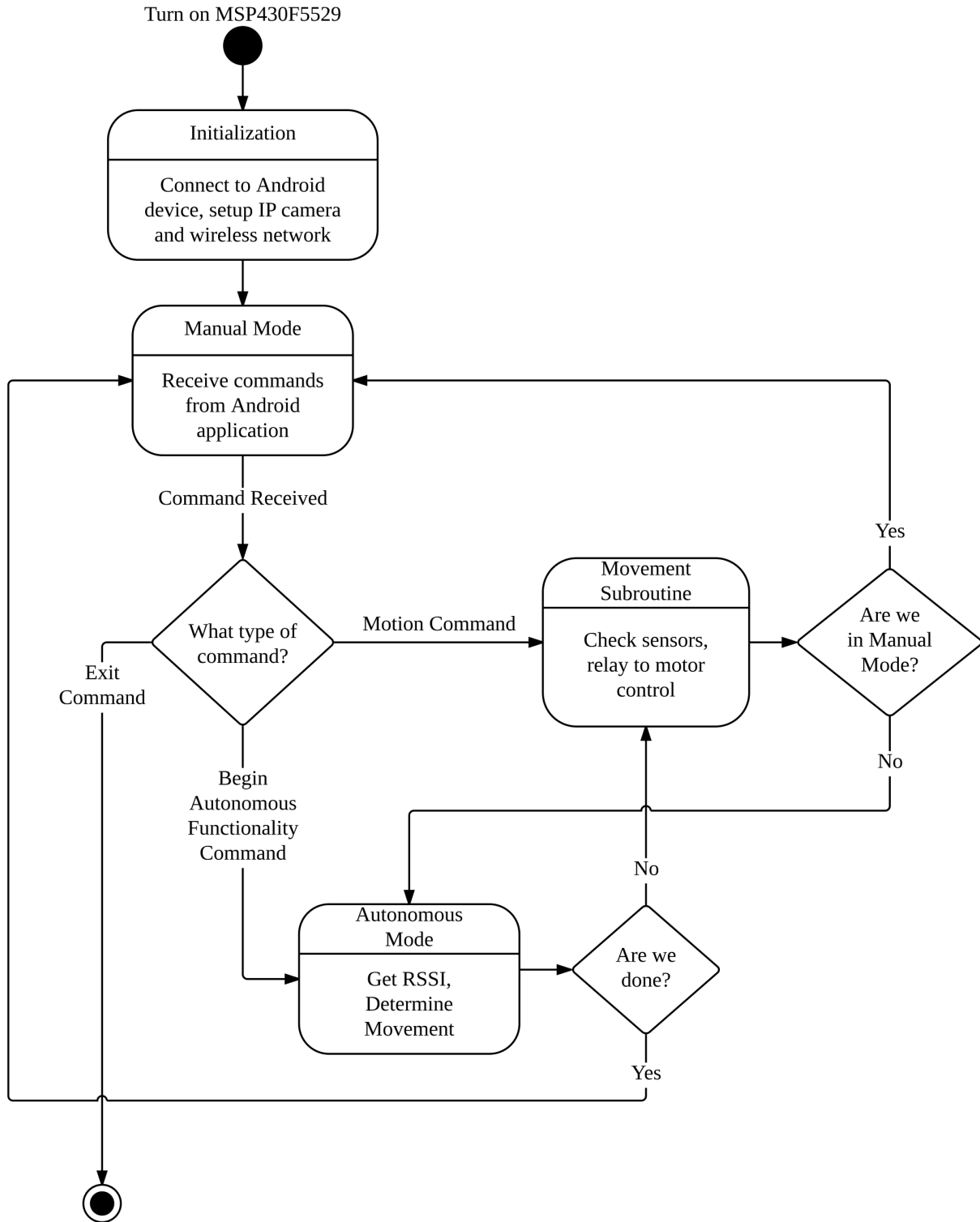

Figure 5.2.3.A - Microcontroller Code State Diagram

6.0 Project Prototype Construction and Coding

6.1 Parts Acquisition

6.1.1 Free Samples

The Wi-Fi Seeker project requires many components such as the microcontroller, Bluetooth and wireless modules, IP camera. In order to connect these parts as well as build the motor controllers and MPPT charge controller, several small parts such as resistors, capacitors, inductors, headers, and connectors will need to be acquired. While it is feasible to purchase these parts from a vendor, some manufacturers offer free samples of their products. They usually ship it promptly and for free. Some manufacturers that participate with free samples are Texas Instruments, Fairchild Semiconductor, and Linear Technology. Usually, they allow a maximum number of samples per order such as five. Once shipped, it normally arrives within a week. This resource will allow the group to save money by using these free parts for initial development and testing before the circuits are finalized.

6.1.2 Texas Instruments

Texas Instruments is one of the largest developers of components for embedded systems. For each part that TI produces, there are several schematics and datasheets to look at, as well as thousands of reference designs for every kind of embedded application, and they are all free to use. This will be particularly helpful since the Wi-Fi Seeker robot will be equipped with TI's MSP430F5529 microcontroller. Using the vast database for related projects and compatible parts, Texas Instruments will be an excellent resource for various datasheets and references for the Wi-Fi Seeker robot.

6.1.3 Digi-Key

Many of the parts that cannot be obtained through the various free sample programs will be ordered through Digi-Key. They have a large inventory of almost every electrical part. The prices are reasonable and the shipping rate is also cheap. Group 30 has previous experience with ordering from them before. Therefore, they will be to go to retailer for purchasing our parts.

6.1.4 SparkFun Electronics

SparkFun is a distributor for hobbyists and other customers who enjoy making embedded systems. They offer a wide variety of components for a number of different functions, as well as complete breakout boards and PCBs. Many of the parts for the Wi-Fi Seeker robot will be purchased from SparkFun, such as the wireless and Bluetooth modules. Along with the various parts are user manuals and datasheets as well as a community that offers reference designs and other applications for the parts sold by SparkFun.

6.2 PCB Manufacturing and Assembly

One of the requirements for UCF's Senior Design class is to have a custom printed circuit board (PCB) for the project. Having a custom PCB will make the project have a look of higher quality and will this appear more professional. One of the most well-known PCB design softwares is Eagle Cad. Eagle Cad offer a free version that has enough features to meet the requirements of the Wi-Fi Seeker robot, and also has a file format that most manufactures accept. As for which vendor to choose to print the PCB, there are many options available. As most manufacturers accept multiple file formats, this will allow a wider range of manufactures to be compared, and the manufacturer that provides the best price, review and delivery time will ultimately be chosen as the vendor for the Wi-Fi Seeker robot's PCB.

6.2.1 4PCB

4PCB is located in the USA and they offer a student program for college students. Engineering students will receive a discount should they order their PCB from them. 4PCB offers 2 layer full spec PCB at the cost of \$33 per PCB, with no minimum on how many PCBs must be ordered. A 4 layer full spec PCB is available at the cost of \$66 each, and also has no minimum. 4PCB also offers their own PCB layout software for free, as well as a PCB file checker.

6.2.2 Express PCB

Express PCB charges a flat rate for all 2 layer and 4 layer PCBs. An order must include three 2 layer PCB boards with dimensions 2.5 in x 3.8 in, with a cost of just \$51 plus shipping or a 4 layer board for \$98. Orders that are submitted Monday through Friday by 2:00pm ET are shipped the next business day.

6.2.3 OSH Park

OSH Park offers a community printed circuit board (PCB) order. These are lead free board (ENIG finish) that are manufactured in the USA and are shipped for free anywhere in the world. They offer 2 layer boards at \$5 per square inch and 4 layer boards at \$10 per square inch. When an order is placed three boards are printed and shipped in under 12 calendar days from ordering.

6.2.4 UCF Radio Club

The UCF Radio Club is located in ENGR 456A on UCF main campus. They builds antennas, radios, and other practical electronics from scratch. With the experience that the members of this club posses, the Wi-Fi Seeker robot teams plans to utilize this resource when it comes to soldering parts on the PCB. Additionally, the club members may be asked for advice regarding to potential problems that are encountered when designing the PCB layout.

6.2.5 TI Innovation Lab

The TI Innovation Lab located in Engineering II on UCF main campus offers a place where students can prototype their ideas. The lab provides students with equipment to build, test, and fine-tune prototypes, including soldering kits, oscilloscopes, voltage regulators, laser cutters, a 3D printer, and many more lab electronics and tools. The lab is monitored by professionally trained advisors who are there to assist students with help should they run into any trouble. These advisors will be valuable should the Wi-Fi Seeker robot run into any major issues. This lab is the main location where the robot prototype will be built and tested.

6.3 Final Coding Plan

6.3.1 Android Application

The Android application will be written in the Java and Android XML languages. It will feature two activities, the InitialActivity and the MainActivity. Upon application startup the InitialActivity will be run, which will allow the user to connect the IP camera on the robot to the application in order for video streaming to take place. After this initial setup is complete, the MainActivity will be run until the application is exited. The MainActivity will have two modes: manual and autonomous. In manual mode the user will be able to see the current strength of the Wi-Fi signal that the robot is connected to, see the video stream from the IP camera mounted on the robot, and control the motion of the robot. Should the user enter autonomous mode, s/he will be able to watch the current strength of the Wi-Fi signal fluctuate as well as the video stream as the robot attempts to complete its mission of finding the location where the strongest connection to the wireless network it is connected to is. Once the location is found, an alert will appear within the application in order to notify the user that the Wi-Fi Seeker robot has successfully completed its mission. Figure 6.3.1.A notes the key methods that will be written for the application and where in the application structure they will be located.

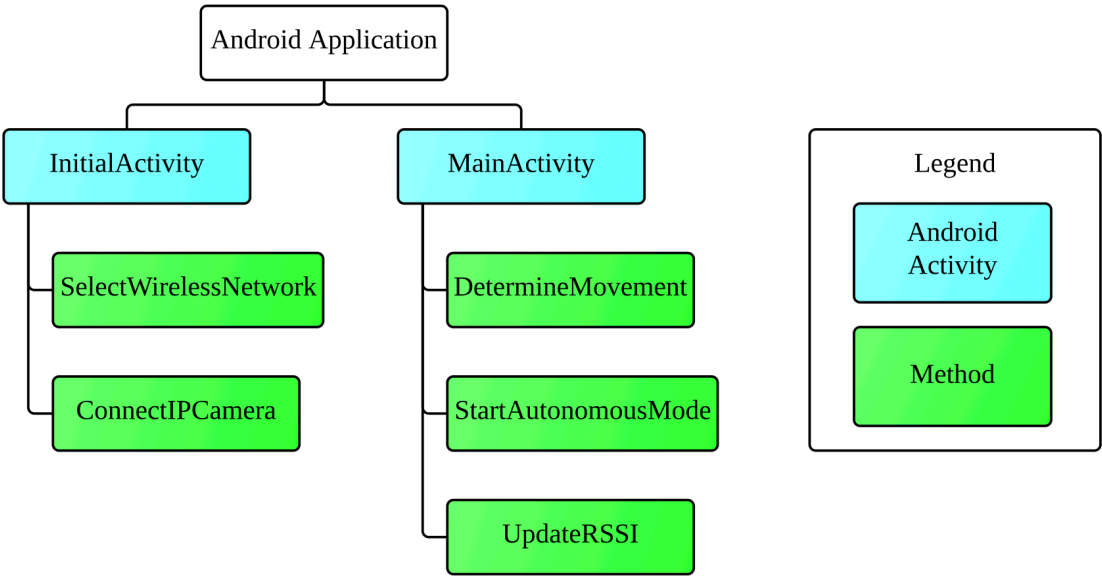

Figure 6.3.1.A - Android Application Structure of Key Methods

6.3.2 Microcontroller

The MSP430F5529 microcontroller will have its own code separate from the Android application. To program the microcontroller, the language C will be used. The way that the main functionality will be divided is into three distinct modes: setup, manual, and autonomous modes. The setup code for the MSP430F5529 will be for setting up the connection between the microcontroller and the WiFly module. When the user first launches the Android application and turns on the Wi-Fi Seeker robot, the wireless module will be initialized. In order to do this, the user will be sending commands to the MSP430F5529 using Bluetooth, which will in turn access the code on the MSP430F5529 in order to relay the commands to the wireless module. The code on the MSP430F5529 for the setup section will be fairly linear. The user will choose a wireless network to connect to, then enter the appropriate account name and password if it is a secure network. This portion of the code will only be executed when the user is connecting to a wireless network, and once it is completed the next section of code will execute, i.e. manual mode.

In manual mode the MSP430F5529 will constantly be waiting for a command to be issued by the user via the Android application. When the user hits a button within the application, the Bluetooth module on the robot will receive the command and the MSP430F5529 will be sent the command. There are five possible commands that the user can send: four of them are directional, and the fifth is an indicator that the MSP430F5529 should exit manual mode and instead enter autonomous mode. Unless this fifth command is received, the MSP430F5529 will remain in manual mode until shutdown. If any of the four directional commands are received, or if some combination of the directional commands are received, the MSP430F5529 will signal the motors appropriately such that the robot moves how the user specified. Also while the manual mode code is executing, within the main loop will be a command to get the current RSSI value of the wireless signal and send it back to the Android device.

In autonomous mode, the MSP430F5529 will be executing its algorithm to determine where the location that the wireless network it is connected to is strongest. The most important command in this portion of the code is the call to the RSSI method of the wireless module, which asks the WiFly module to return the current RSSI value of the wireless network it is connected to. The algorithm for determining the location where the wireless signal is strongest is as follows: the robot will roam about an area. First the robot will note its current signal strength, then move forwards if possible. Should the wireless signal get weaker as the robot moves forwards, the robot will turn around 180 degrees and move in the other direction. If the signal strength is getting stronger, the robot will continue to move in the same forwards direction. If the signal strength does not change during a certain time interval, the robot will turn left (i.e. rotate counter-clockwise 90 degrees) and then move forward, repeating the same steps as above. If the robot cannot move in a certain direction, it will turn left and move in that direction instead. As the robot is moving about it will keep track of the recent RSSI values it has measured. If the robot finds a point where it is moving in a cyclic motion, the algorithm is complete. This is because the robot will continuously be circling around the point where the RSSI value is the highest, and every time the robot tries to move in a new direction the RSSI value is decreasing. Once it has found the location of the local maximum RSSI value, the robot will signal the Android application and then revert back to manual mode.

The complexity of the code on the microcontroller can be more easily represented visually, as shown in Figure 6.3.2.A below, which breaks down the organization of the code. The so-called modes of operation are larger subroutines, that have calls to simpler subroutines. Then there are certain subroutines that need to be accessed by multiple modes of operation, thus they are on the same level as the modes themselves.

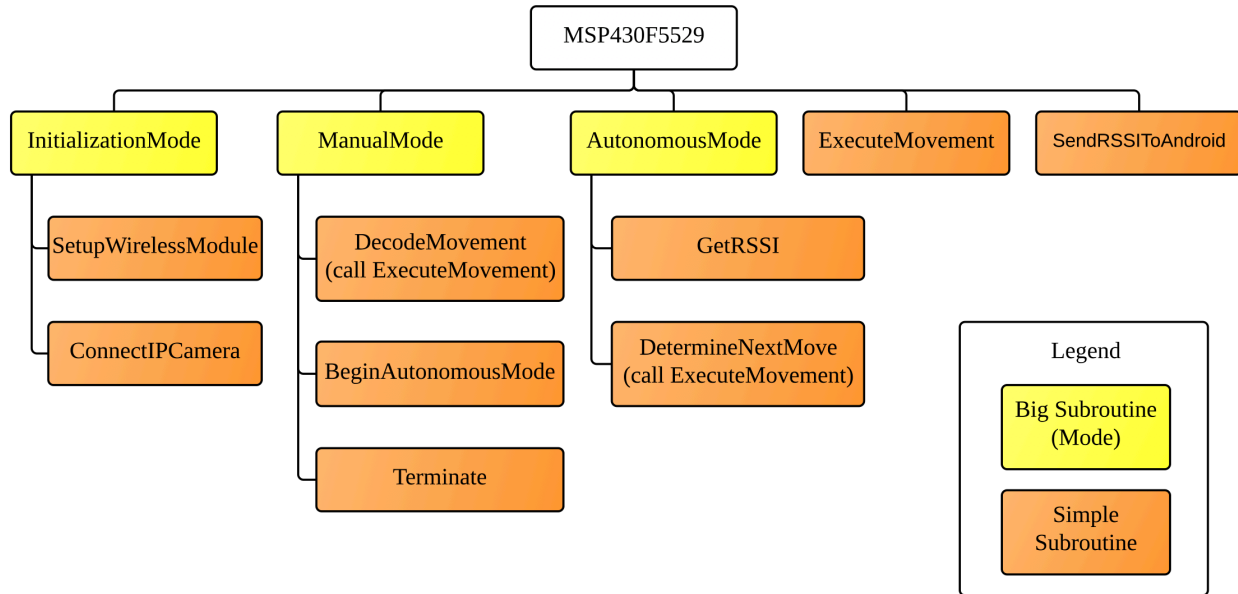

Figure 6.3.2.A - MSP430F5529 Code Structure and Key Subroutines

7.0 Project Prototype Test Plan

Each test case will contain a description explaining how it will be performed, equipment required, purpose, and expected results. The testing will be done in two phases. The first phase will test each individual subsystem and the second phase will test the system as a whole. The second phase will make sure that all the subsystems are behaving correctly when integrated together.

7.1 Hardware Test Environment

The testing environments that will be utilized are the Senior Design lab, the TI Innovation Lab, team members' homes, and various locations around the UCF main campus. The Senior Design and TI labs will be mostly used to test the electrical components thanks to the availability of tools and equipment. Team members' homes will be used to test the prototype functionality.

7.1.1 Motor Controller Tests

Test Name: H-Bridge Functionality Testing

Objective: This test is to ensure that the H-Bridge will properly control the direction of the flow of current through the output terminals. Also it will check to see if the transistor can handle the amount of current the motor needs.

Equipment:

- Breadboard
- DC Power supply
- Function Generator
- Oscilloscope
- Multi-meter
- Resistors $1k\Omega$ x2
- Resistors 470Ω x2
- Various load resistors
- MJE2955TG x2
- MJE3055TG x3
- 1N4004G x4
- 2N5551 x2
- Capacitor 100nF

Procedure:

1. Assemble the circuit on the breadboard according to Figure 4.3.2.B.
2. Probe each transistor to ensure that the expected voltage and currents are appearing.
3. Check the voltages and current with VCC set to 7V, 10V, and 14V respectively.
4. Ensure that the transistors are not overheating, if they do heat sinks may be added.
5. Use the function generator to create a step function for the enable line.

6. Set the frequency to 100 Hz
7. Vary the duty cycle from 0% to 100% in 10% increments. Measure each transistor at each interval.

Expected Result: The output will have a drop that is less than VCC caused by the voltage drop across the Bi-polar transistor. After the enable line there should be an increase in voltage and current at the load terminals.

Test Name: DC Motor Test

Objective: To ensure that all of the motor controller's components work with the DC motor.

Equipment:

- Breadboard
- DC Power supply
- Function Generator
- Oscilloscope
- Multi-meter
- Resistors 1k Ω x2
- Resistors 470 Ω x2
- Various load resistors
- MJE2955TG x2
- MJE3055TG x3
- 1N4004G x4
- 2N5551 x2
- Capacitor 100nF
- DC Motor

Procedure:

1. Use the circuit made in the H-Bridge functionality Test in section 7.1.1 Motor Controller.
2. Verify all components are connected correctly and that the correct voltages are being applied.
3. Slowly raise the voltage from 0-3 V on the PWM control line. At the same time measure the PWM on the oscilloscope. This should change the duty cycle from 0 to 100%.
4. Measure both DIR out lines from the controller. Change the input to digital inputs that controls these. The two DIR lines should never be active simultaneously.
5. Attach the motors and check the stall current at 100% duty cycle.

Expected Result: It is expected that the range for the analog input will be 0 to 3 V for the duty cycle on the PWM. The expected stall current should be around 6.6 A.

Test Name: Robot Chassis with Motor Controller Test

Objective: The objective of this test is to make sure the robot function with a load.

Equipment:

- Motor controller
- Robot chassis
- DC motors
- MSP430
- Battery
- Various resistor

Procedure:

1. Connect all the components correctly to the robot chassis.
2. Place the robot chassis on a surface where the wheels are hanging off so it's stationary.
3. Have the robot wheels move in all directions. (i.e. forwards)
4. Place the robot on the floor.
5. Have the robot move forwards and backwards.
6. Have the robot turn left and right while moving forwards and backwards.
7. Have the robot turn left and right from a stationary position

Expected Result: The robot should be able to move in any specified direction. When the appropriate command is sent, the robot should move in that respective direction. Note that the resistors may need to be changed to allow more current to flow so that the motors can turn the robot from a stationary position.

7.1.2 Sensors Tests

Test Name: Sensor Test

Objective: The objective of this test is to verify that each sensor is able to detect any object blocking its path.

Equipment:

- HC-SR04 sensor x2
- Sharp GP2Y0A21YK sensor x2
- Multimeter
- Ruler
- Breadboard
- DC power supply
- Obstacle (flat object)

Procedure:

1. Verify that the HC-SR04 sensor is connected to the breadboard.
2. Place the obstacle five feet away from the sensor.
3. Measure the output voltage with the multimeter while moving towards the sensor.
4. Repeat steps 1-3 with the remaining HC-SR04.
5. Repeat steps 1-3 with the Sharp GP2Y0A21YK sensor

Expected Result: The voltage output should change as the obstacle gets closer to the sensor. This will allow for the most accurate reading in order to detect obstacles.

7.2 Hardware Specific Testing

7.2.1 Battery Life

Test Name: Battery Life Test

Objective: The objective of this test is to measure the battery life of the robot.

Equipment:

- MSP430F5229
- Timer
- Digital Multimeter
- Oscilloscope
- Battery
- Solar Panel
- MPPT Charging Controller
- Voltage Regulators
- Motor Controller
- Bluetooth Module
- Wi-Fi Module
- IP Camera
- Proximity Sensor
- Infrared Sensor

Procedure:

1. Connect the digital multimeter in series in between the battery and a node to the regulators and motor controller.
2. Set the multimeter to measure current.
3. Set the duty cycle output from the microcontroller to 10%. This ensures too much current doesn't flow through the multimeter and damages it.
4. Measure the current flowing through the multimeter,
5. Adjust the duty cycle until a desired current is obtained.
6. Measure the amount of time it takes for the battery to fully discharge and the motors stop running.
7. Compare this time to the Battery Life vs. Discharge Graph in Figure 3.2.12.A.

Expected Result: Once the time has been measured, the graph shows the estimated battery life based on the operating current. For example, if the current set was at 5 Amps, the battery life should be about 25.2 minutes.

7.2.2 Battery Charging

Test Name: Solar Panel Charging Test

Objective: The objective of this test is to see if the solar panel charges the lithium polymer battery.

Equipment:

- Digital Multimeter
- Battery
- Solar Panel
- MPPT Charging Controller

Procedure:

1. Locate an open area outside with a lot of sunlight shining.
2. Place the solar panel in direct sunlight.
3. Connect the solar panel to the MPPT Charging Controller.
4. Connect the MPPT Charging Controller to the battery.
5. Connect the digital multimeter in series in between the charging controller and the battery.
6. Measure the current flowing into the battery.
7. Check the status indicator lights on the charging controller to see if it's charging.

Expected Result: The solar panel should harvest the energy of the sun and convert it into current. The solar panel has a current of 590 mA when operating at maximum power. Therefore, the current measured on the multimeter should be about 590 mA. When the battery is charging, the STAT1 red LED on the charging controller should be illuminated. When the battery is fully charged, the STAT2 green LED on the charging controller should be illuminated.

Test Name: Maximum Power Point Tracking

Objective: The objective of this test is to see if the MPPT Charging Controller operates the solar panel at its maximum power efficiency.

Equipment:

- Digital Multimeter
- Battery
- Solar Panel
- MPPT Charging Controller

Procedure:

1. Locate an open area outside with a lot of sunlight shining.
2. Place the solar panel in direct sunlight.
3. Connect the solar panel to the MPPT Charging Controller.
4. Connect the MPPT Charging Controller to the battery.
5. Measure the voltage across the solar panel.

6. Measure the current going into the MPPT Charging Controller.
7. Calculate the power of the solar panel by multiplying the voltage by the current.

Expected Result: The MPPT Charging Controller should keep the voltage at 17.3V, which is the voltage at the solar panels' maximum power. The current flowing from the solar panel should be 0.59A, which is the current at the solar panels' maximum power. After calculating the power, it should be about 10 Watts, which is the solar panels' rated maximum power.

Test Name: Battery Current Test

Objective: This objective of this test is to see if the battery can supply all the current needed to operate the subsystems.

Equipment:

- Digital Multimeter
- Oscilloscope
- Battery
- Voltage Regulators
- Motor Controller
- Wi-Fi Module
- Bluetooth Module
- Proximity Sensor
- Infrared Sensor
- IP Camera

Procedure:

1. Connect the digital multimeter in series in between the battery and the motor controllers.
2. Set the multimeter to measure current.
3. Set the duty cycle output from the microcontroller to 100%. Make sure the digital multimeter can handle currents of at least 15A.
4. Measure the current going flowing into the motor controller.
5. Connect the digital multimeter in series in between the 5V regulator and a node connected to the webcam and two sensors.
6. Measure the total current flowing to them.
7. Connect the digital multimeter in series in between the 3.3V regulator and microcontroller, Bluetooth module, and WiFi module.
8. Measure the total current flowing to them.

Expected Result: The current flowing into each motor controller should be about 13.2A. The total current flowing into the webcam and two sensors should be between 1.24A and 1.26A. The total current flowing into the microcontroller, Bluetooth module, and WiFi module should be between 65.4mA and 357.2mA.

Test Name: Voltage Regulation

Objective: The objective of this test is to check if the voltage regulators are regulating correctly, so that the components receive the correct voltage.

Equipment:

- Digital Multimeter
- Battery
- Voltage Regulators

Procedure:

1. Connect the battery to the voltage regulators.
2. Connect a 10k ohm resistor to the output of the voltage regulators to load it.
3. Use a digital multimeter to measure the voltage across the 5V regulator and the 3.3V regulator.

Expected Result: The measured voltage across the 5V regulator should be about 5 volts. The measured voltage across the 3.3V regulator should be about 3.3 volts.

7.3 Software Test Environment

7.3.1 Phone

The Android application for the Wi-Fi Seeker robot is being developed specifically for a standard Android device, which is a smart phone. Out of all of the devices running the Android operating system, there are far more devices that are smart phones than there are tablets or applications with screens larger than 6 inches. Therefore the Android application will be optimized for use on smart phones, or devices that have screens smaller than 6 inches. While there are an incredible number of different Android smartphone devices on the market, which are all produced by a variety of companies, as long as the firmware is the same there should be no issue regardless of the internal components of each smartphone device. Therefore by testing the Wi-Fi Seeker robot on a single Android device running the KitKat operating system will be sufficient to say that the application will work for every device running the KitKat operating system. However the group will make its best effort to test the application on several different devices.

7.3.2 Tablet

In addition to testing the Android application for the Wi-Fi Seeker robot on a standard Android smartphone device, the application will also be tested on a tablet. The only major difference between these two platforms are internal components and screen size. As long as the version of the Android operating system is KitKat, which is the target platform for the application, then there should be no issues regarding the hardware differences between tablet and smartphone devices. As for screen size, there is a difference. In order to be compatible with screen sizes 6 inches and larger, separate software directories need to be made in order to accommodate the additional space available on the screen. This will be done by having properly sized images and

layouts for the larger screen resolutions, which will thus make the application compatible with Android tablets and the like.

7.4 Software Specific Testing

The Wi-Fi Seeker relies heavily on its code in order to be operational. Without the Android application, the user would not be able to control the robot, or view the video stream coming from the camera on the robot. Equally important is the code for the autonomous functionality, which is the purpose of this project. Therefore it is pertinent that the software tests are thorough and that the Wi-Fi Seeker robot passes them all, or else the user experience may be poor.

7.4.1 Wireless Module Tests

Test Name: Wireless Module Initialization Test

Objective: The objective of this test is to make sure that the user can initialize the wireless module on the robot using the Bluetooth communication between the Android device and the Wi-Fi Seeker robot.

Equipment:

- MSP430F5229
- WiFly wireless module
- Bluetooth module
- Motor controllers
- Android device with application

Procedure:

1. Begin with the robot powered off. Turn on the robot.
2. Establish the Bluetooth connection between the Android device and the Bluetooth module. Then open the Wi-Fi Seeker application on the Android device.
3. Confirm that the application is asking the user to select a wireless network to connect to.
4. Complete the camera portion of the setup in order to get to the MainActivity in the application.
5. Now that the application is in manual mode, verify that there is an RSSI value being displayed.
6. Manually move the robot and verify that the RSSI value changes.

Expected Results: When the application is first started the user will be in the initialization phase, where s/he will configure the settings for the wireless module. There should be a list of wireless networks to choose from, and it is expected that valid networks will appear in this list. Upon selecting a wireless network and completing the setup, the RSSI value in the application should update as the robot moves closer to / further from the router it is wirelessly connected to.

Test Name: RSSI Accuracy Test

Objective: The objective of this test is to determine if the measured RSSI value of the wireless network is reasonable and accurate.

Equipment:

- MSP430F5229
- WiFly wireless module
- Bluetooth module
- Motor controllers
- Android device with application

Procedure:

1. Begin with the robot powered on, connected to a wireless network and connected to the Android device.
2. Establish the location of the router that is broadcasting the wireless network that the robot is connected to.
3. In manual mode, make the robot move towards the router, and take note of the RSSI value that is displayed in the Android application.
4. In manual mode, make the robot move away from the router, and take note of the RSSI value that is displayed in the Android application.

Expected Results: In order for the Wi-Fi Seeker to work, the RSSI value needs to be accurate. This means that the closer to the router that the robot is, the RSSI value should be closer to -90 dBm, and the further away from the router that the robot is, the RSSI value should be closer to -50 dBm.

7.4.2 Bluetooth Communication Tests

Test Name: Initialization of Bluetooth Test

Objective: The objective of this test is to make sure that the user can initialize the Bluetooth connection between the Android device and the Wi-Fi Seeker robot.

Equipment:

- MSP430F5229
- Bluetooth module
- Android device with application

Procedure:

1. Begin with the robot powered off. Turn on the robot.
2. Check the LED on the Bluetooth module; it should be blinking quickly at a rate of 1Hz.
3. Turn on Bluetooth communication for the Android device, and follow the steps to connect to the Bluetooth module.
4. After making a connection again check the LED on the Bluetooth module.

Expected Results: When the Bluetooth module is first turned on, it is in "discoverable mode" which can be recognized by the LED blinking rate of 1Hz. After the Android device connects to the module, the LED blinking rate will stop blinking and will be solid and on.

Test Name: Integrated Bluetooth Communication Between Android Device and Robot

Objective: The objective of this test is to test the communications between the Android application and the Wi-Fi Seeker robot after integration of systems.

Equipment:

- MSP430F5229
- Bluetooth module
- Motor controllers
- Android device with application

Procedure:

1. Begin with the robot powered on, connected to a wireless network and connected to the Android device.
2. In manual mode, give the robot a directional command (i.e. forward) and take note of the motion of the robot.
3. Repeat step 2 for each of the directions.
4. In manual mode, give the robot a multi-directional command (i.e. forward and left) and take note of the motion of the robot.
5. In manual mode, push the button to start the autonomous functionality.

Expected Results: The robot should move in accordance with the motion command given to it. Therefore if the user tells the robot to move forward using the application, the robot should move in the forward direction. If the robot is told to move forward and right, the robot should move in a North-Eastern direction, or equally forward and to the right. Should the user push the forward and backward buttons at the same time, or the left and right buttons at the same time, the robot should not move. Once the autonomous mode button is pushed, the application should change screens and the robot should begin moving by itself.

7.4.3 Video Streaming Tests

Test Name: Initialization of Video Streaming Test

Objective: The objective of this test is to make sure that the user can initialize the video stream between the Android device and the IP camera mounted on the robot.

Equipment:

- MSP430F5229
- IP Camera
- Android device with application

Procedure:

1. Begin with the robot powered off. Turn on the robot and initialize the Bluetooth connection.
2. Complete the first part of the initial setup for selecting a wireless network.
3. On the screen for the camera setup, enter the IP address for the IP camera and click the "refresh video connection" button.
4. Complete the setup by hitting the "finish" button, and the application should be displaying the MainActivity in manual mode.

Expected Results: When the user enters the IP address of the camera and hits the "refresh" button, the container for the video stream should update and show the video stream coming from the IP camera. Once the user goes to the MainActivity, the same video stream should be present and viewable from the Android application.

Test Name: Integrated Video Streaming Test

Objective: The objective of this test is to make sure that the video stream works properly throughout the manual and autonomous modes of operation of the robot.

Equipment:

- MSP430F5229
- Bluetooth module
- Wireless module
- IP Camera
- IR sensors
- Ultrasonic Sensors
- Motor controllers
- Android device with application

Procedure:

1. Begin with the robot powered on, connected to a wireless network and connected to the Android device.
2. In manual mode, execute several motion commands. Verify that as the robot moves, the video stream updates.
3. In manual mode, hit the button to begin the autonomous functionality.
4. Wait for the autonomous functionality to complete and for the application to return to manual mode.

Expected Results: When the user is in the manual mode part of the application, the video stream should be updating as commands are sent from the Android device to the robot and as it moves about. When the autonomous functionality begins, the application screen will change but the video stream should still work. As the robot completes its mission the video stream should be updating at a reasonable rate. Once the autonomous functionality completes and the robot returns to manual mode, the video stream should still be working.

7.4.4 Obstacle Avoidance Tests

Test Name: Software Obstacle Avoidance

Objective: The objective of this test is to test the obstacle avoidance system and ensure that the robot does not collide with any obstacles during its autonomous functionality.

Equipment:

- MSP430F5229
- Bluetooth module
- IR sensors
- Ultrasonic Sensors
- Motor controllers

Procedure:

1. Begin with the robot powered on and connected to the Android device.
2. Put the robot in manual mode to allow the user to manually control the robot's motion.
3. In manual mode, command the robot to move into obstacles.

Expected Results: The robot should never collide with any obstacles. Even though the user is controlling the motion of the robot, when the sensors notice an object the robot's motion should cease, thereby disallowing user error.

7.5 Integration Testing

Test Name: Obstacle Avoidance Test

Objective: The objective of this test is to test the obstacle avoidance systems.

Equipment:

- Full prototype Wi-Fi Seeker
- Wireless network
- Android device

Procedure:

1. Power up the Wi-Fi Seeker robot and the corresponding application on the Android device. Complete all initial setup.
2. Place the robot in autonomous mode and monitor its movements until mission completion.

Expected Results: The robot should be able to navigate through any environment it is placed in and be able to execute the autonomous functionality without colliding with any obstacles. The user should observe that when an obstacle has been detected, the robot should immediately change its course to avoid a collision.

Test Name: Battery Life and Recharge Test

Objective: The objective of this test is to test the life of the robot as well as to ensure that the batteries can successfully be recharged using the solar panel and charge controller.

Equipment:

- Full prototype Wi-Fi Seeker
- Wireless network
- Android device

Procedure:

1. Power up the Wi-Fi Seeker robot and the corresponding application on the Android device. Complete all initial setup.
2. Continue to either manually control the robot or use the autonomous functionality until the robot's batteries run out of juice. Make sure the robot dies in a well-lit area.
3. Once the batteries die, allow the Wi-Fi Seeker to rest for a period of time. Time intervals of 10, 15, 20, and 30 minutes should be tested.
4. After waiting a set amount of time, turn the robot on and again begin to control it and start the autonomous functionality.

Expected Results: The robot should have a reasonable life span, such as 30-60 minutes of constant use. Once the batteries die, the robot should be left to charge. Once recharged, the user should be able to again use the robot for a reasonable amount of time, and the robot should be able to complete at least one mission after a 30-minute recharge period. Note that this is not enough time to fully recharge the batteries, just a temporary recharge.

Test Name: Full Integration Test

Objective: The objective of this test is to make sure that the robot does what it was designed to do - locate where its connection to a wireless signal is strongest, autonomously.

Equipment:

- Full prototype Wi-Fi Seeker
- Wireless network
- Android device

Procedure:

1. Power up the Wi-Fi Seeker robot and the corresponding application on the Android device. Complete all initial setup.
2. Send manual commands to ensure that the robot can be manually controlled.
3. Send the command for the robot to begin its autonomous functionality and go on its mission to find the location of the strongest Wi-Fi signal.

Expected Result: The prototype robot should be able to find the strongest Wi-Fi signal in autonomous mode. While the robot is searching for the Wi-Fi signal it should be sending video to the Android device so the user can see where the robot is heading. The robot should also be avoiding any obstacle in its path while searching for the Wi-Fi signal. Once the robot finishes its mission it should alert the user via the Android application.

8.0 Administrative Content

8.1 Milestone Discussion

During the Senior Design I class in the Fall 2014 semester, this paper documenting the research and design of the Wi-Fi Seeker robot was written. There is a month-long break between the completion of Senior Design I and the beginning of Senior Design II, during which time the parts for the Wi-Fi Seeker robot will be acquired, the team members will be expected to learn the Eagle CAD PCB software, and initial prototyping will begin. Since there are two semesters worth of effort, the milestones have been divided into two tables, with Table 8.1.A reflecting the milestones for Senior Design I and Table 8.1.B for Senior Design II. These tables contain the timelines for the milestones of the project and in what time frame each task should be completed.

Table 8.1.A - Senior Design I Timeline

Senior Design Project Plan	Duration (days)	Start Date	End Date
Select project and write proposal	7	9/2/14	9/8/14
Meeting to outline research	1	9/9/14	9/9/14
Research Wi-Fi and communication with Android	14	9/9/14	9/22/14
Research motors, servos, sensors	14	9/9/14	9/22/14
Research solar panels and batteries	14	9/9/14	9/22/14
Research video transmission	14	9/9/14	9/22/14
Meeting to discuss sponsorship, progress	1	9/16/14	9/16/14
Begin design paper, continue research	14	9/23/14	10/6/14
Meeting to finalize sponsorship application	1	9/23/14	9/23/14
Continue design paper and research	7	10/7/14	10/13/14
Meeting to discuss design and progress	1	10/14/14	10/27/14
Design Solar Panel / Power Management	21	10/14/14	11/3/14
Design Motion and Sensor System	21	10/14/14	11/3/14
Design Microcontroller Software and Wi-Fi Tracking System	21	10/14/14	11/3/14
Design Android Application			
Design Video Streaming System	21	10/14/14	11/3/14
Meeting to discuss progress, problems	1	10/21/14	10/21/14
Meeting to discuss progress, problems	1	10/28/14	10/28/14
Finalize designs for all subsystems	14	11/4/14	11/17/14
Research/Learn Eagle PCB Software	7	11/18/14	11/25/14
Finalize System and order parts	7	11/18/14	11/25/14
Finalize Senior Design I paper	14	11/18/14	12/2/14

Table 8.1.B - Senior Design II Timeline

Senior Design Project Plan	Duration (days)	Start Date	End Date
Begin SD2, inventory, meeting to discuss plan for the semester	1	1/12/15	1/12/15
Design/Test Software	21	1/13/15	2/2/15
Prototype Communication and Wi-Fi tracking system	28	2/3/15	3/3/15
Prototype Solar Panel / Power System	28	2/3/15	3/3/15
Prototype Motion and Sensors System	28	2/3/15	3/3/15
Prototype Video Streaming System	28	2/3/15	3/3/15
Weekly progress meeting	1	2/10/15	2/10/15
Weekly progress meeting	1	2/17/15	2/17/15
Weekly progress meeting	1	2/24/15	2/24/15
Test/Debug communication and Wi-Fi Tracking System	19	2/24/15	3/15/15
Test/Debug Power System	19	2/24/15	3/15/15
Test/Debug Motion System	19	2/24/15	3/15/15
Test/Debug Video Streaming System	19	2/24/15	3/15/15
Test/Debug Sensors and Avoidance system	19	2/24/15	3/15/15
Weekly progress meeting	1	3/3/15	3/3/15
Weekly progress meeting	1	3/10/15	3/10/15
Integrate all systems	14	3/16/15	3/29/15
Test/Debug integrated Wi-Fi Seeker	14	3/30/15	4/12/15
Finalize documentation and presentation	10	4/13/15	4/23/15
Final Presentation	5	4/20/15	4/24/15

8.2 Finances and Budget Discussion

8.2.1 Project Sponsorship

The Wi-Fi Seeker robot had an initial funding request of \$1,101.00 by Duke Energy. However, it turned out that Leidos Engineering would be sponsoring instead of Duke, and of the initially requested amount only \$375.00 will be reimbursed. This will prove to be a challenge, since the members of Group #30 will be directly responsible for any costs over the \$375.00 budget. As a result, some expenses will have to be cut back and the quality of some of the parts must be reduced in order to keep the project low-cost. The benefit of this is that any hobbyists who later want to replicate the Wi-Fi Seeker robot will be able to do so for much cheaper than the initial estimate.

8.2.2 Budgeting

The initial budgeting was constructed at the dawn of the Wi-Fi Seeker project, while it was still in the idea phase and before any of the design had been done. While some research was

conducted prior to making the initial budget, it was fairly preliminary, though all the major components of the Wi-Fi Seeker robot were included in the initial budget, which was proposed for funding for a total of \$1101.00, as seen in Table 8.2.2.A below.

Table 8.2.2.A - Initial Proposal Budgeting

Part	Cost Per Unit	Quantity	Total Cost
MSP430-F5529 Development Board	\$13	1	\$13.00
MSP430-F5529 Chip	\$10	1	\$10.00
Wi-Fi Module	\$50	1	\$50.00
H Bridge (DRV8833)	\$10	2	\$20.00
Voltage Regulator	\$4	4	\$16.00
Android device	*Free	1	*\$0.00
Lithium-polymer battery pack	\$40	2	\$80.00
Lithium-polymer Charge Controller	\$5	2	\$10.00
Smart Charger	\$30	1	\$30.00
Solar panel	\$160	1	\$160.00
Brushless DC Motor	\$25	2	\$50.00
Servo	\$15	2	\$30.00
PCB Manufacturing	\$80	1	\$80.00
MPPT	\$30	1	\$30.00
Breadboard	\$30	3	\$90.00
Ultrasonic distance sensor	\$30	1	\$30.00
Infrared sensor	\$15	2	\$30.00
Wiring	\$12	1	\$12.00
Robot base components	\$300	1	\$300.00
Camera	\$60	1	\$60.00
Total Cost			\$1101.00

* A team member already owns this component, which will be used for this project.

After receiving the new of the money that the Wi-Fi Seeker robot would be granted, it was clear that a budgeting readjustment would be necessary. For instance, \$300.00 for a robot base is now an exorbitant amount, and would be 80% of the budget by itself. As such, the final budget has several changes made, including scaling back the cost of some parts, as well as adding parts to the list that were discovered to be necessary for the prototyping of the Wi-Fi Seeker robot as research and design was conducted. The updated budget can be seen in Table 8.2.2.B below.

Table 8.2.2.B - Post-Funding Rewards Budgeting

Part	Cost Per Unit	Quantity	Total Cost
MSP430-F5529 development board	\$12.99	1	\$12.99
MSP430-F5529 chip	\$8.31	1	\$8.31
RN-XV WiFly wireless module	\$34.95	1	\$34.95
2.4GHz duck antenna (for Wi-Fi module)	\$9.95	1	\$9.95
RN41-XV Bluetooth module	\$29.95	1	\$29.95
D-Link DCS-932L IP camera	\$53.24	1	\$53.24
Android device	\$200.00	1	*\$0.00
Ultrasonic Ranging Detector Mod HC-SR04 Distance Sensor	\$3.99	2	\$7.98
Infrared Proximity Sensor- Sharp GP2Y0A21YK	\$13.95	2	\$27.90
Dagu Wild Thumper 4WD All-Terrain Chassis	\$174.95	1	\$174.95
H-Bridge Components	\$2.05	2	\$4.10
Lithium Polymer Battery (RC03217)	\$18.45	1	\$18.45
SolarTech Solar Panel (SPM010P)	\$69.95	1	**\$0.00
MPPT Charging Controller (BQ24650RVAT)	\$5.96	1	\$5.96
5V Switching Regulator (LM26003MHX/NOPB)	\$5.44	1	\$5.44
3.3V Switching Regulator (TPS54336DDAR)	\$3.01	1	\$3.01
Various Circuit Elements (Resistors, etc)	-	-	\$40.00
Breadboard	\$10.00	3	\$30.00
PCB Manufacturing	\$80.00	1	\$80.00
		Total:	\$547.18

*\$0.00: one of the team members owns this component already, therefore there is no cost.

**\$0.00: this component was donated to the group and therefore there is no cost.

8.3 Division of Labor

The division of labor will be divided among the team members as shown in Figure 8.3.A. Since Christina is the only Computer Engineer, she will be responsible for the major coding and communications sections. This includes the Android application that will be developed, the Bluetooth communication between the MSP430F5529 and the Android device, the wireless module that will be used to determine a wireless network's strength, and the video streaming aspect. She will also be the chief engineer for the autonomous algorithm for the MSP430F5529. The two Electrical Engineers will be responsible for the hardware of the project. Jimmy will be responsible for designing the motor control that will be responsible for the motion of the robot. He will also be responsible for the obstacle avoidance system, which is based off of the ultrasonic and infrared sensors that will assist the robot in its autonomous functionality. Finally, Adrian will be tasked with the challenge of powering the entire Wi-Fi Seeker robot and all its subsystems. This involves properly connecting the batteries to each component such that each part gets the correct amount of voltage and current. He is also responsible for the solar charging system, where the maximum power point tracker will be connected to the solar panel, which will then be used to recharge the batteries. All members will be responsible for helping design and code the autonomous algorithm for the Wi-Fi Seeker robot, as well as PCB design. Each member

will be required to build circuits and systems to test each subsystem, and then all members will assist in testing the final integrated Wi-Fi Seeker robot.

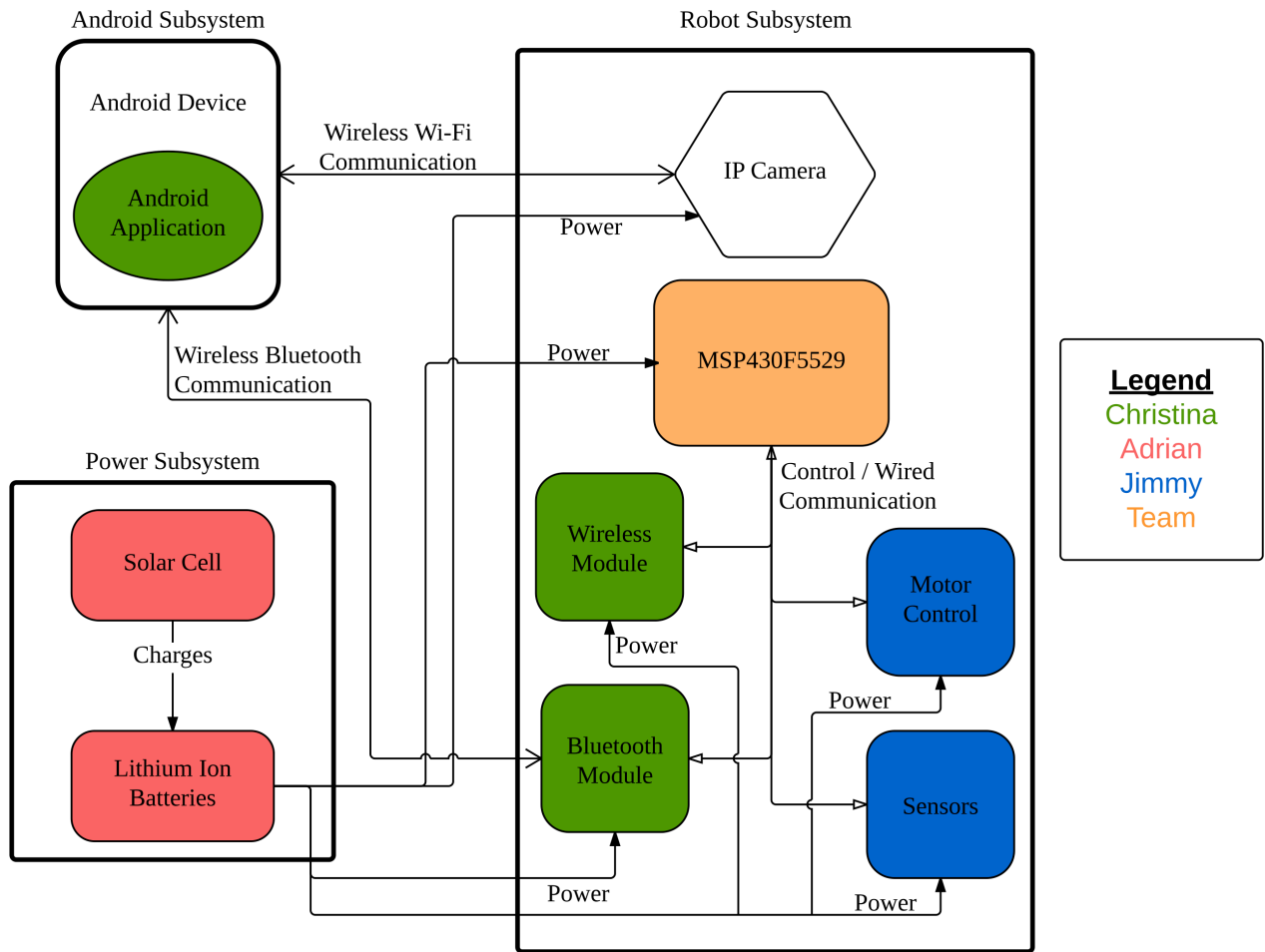

Figure 8.3.A - Team Responsibilities

9.0 Project Summary

The experience gained by completing Senior Design is unlike any other engineering course. It is the final measure of a student's knowledge that has been gained over the years spent in the College of Engineering. In Senior Design engineering students are expected to transition from conceptual knowledge to practical applications. Students are expected to manage time, budgeting, and design constraints. This is a challenging course where the students must conduct a significant amount of independent research in order to be able to design and realize a final goal, where the final goal is a complete functional prototype that has many different features, each implemented by a member of the team.

Working cooperatively with other students over an extended period of time is an invaluable experience. This is how individuals are able to learn what they are capable of alone and what they are capable of as a group. Throughout the semester the members of Group 30 were dependent on each other to do their share, as it was not possible for one person to do all of the work. In the end, Group 30 will produce the Wi-Fi Seeker, which is a robot that involves electronic circuits and high-level logic control design. Creating this robot has provided the group members with knowledge in electrical power, mechanical control, circuit design, algorithm development and implementation, and so much more. Throughout the research and design phase of the project each member has definitely gained valuable knowledge in his/her respective chosen fields. Although a vast amount of knowledge has been gained on the basic fundamental from the prerequisite courses' lectures, it only scratches the surface of the amount of knowledge in these engineering disciplines. The hardware aspect of the project was an eye-opener to the many different components offered by different companies. The fundamentals learned helped the members compare and contrast the similar components offered by various brands. Since they were able to understand the concepts and methodology in the datasheets, they were able to choose components that best fit the needs of the Wi-Fi Seeker robot.

Senior Design II will put all the members' knowledge to the test, as a prototype for the Wi-Fi Seeker robot is created and tested. Although it will be challenging, the members of Group 30 look forward to seeing the Wi-Fi Seeker go from a concept to a fully working prototype.

Appendix A - Copyright Permissions

All copyright permissions for figures used are listed in order in which they are used in this document.

Figure: 3.2.5.A

<http://content.vexrobotics.com/vexpro/pdf/Victor-SP-Talon-SRX-Info-Sheet-20140819.pdf>



wongj92

Tue 11/11/2014 1:04 PM

Mark as unread

To: news@vexrobotics.com;

Greetings,

My name is Jimmy, and I am a senior at the University of Central Florida. I would like to ask for permission to use product images and product datasheets from your website in a design document for my Senior Design coursework.

Thank you,
Jimmy Wong



Lindsey Gideon <lindsey@vex.com>

Thu 11/13/2014 7:17 PM

Inbox

Mark as unread

To: wongj92 <wongj92@knights.ucf.edu>;

- To help protect your privacy, some content in this message has been blocked. To re-enable the blocked features, [click here](#).
- To always show content from this sender, [click here](#).
- Flag for follow up.

Hi Jimmy,

VEX images can be found at our Digital Resources page: <http://www.vexrobotics.com/contact/digital-resources/>

Per the disclaimer at the bottom of the page, logos and other VEX likenesses are made freely available for personal and promotional use. We typically distinguish between personal vs commercial use by checking if they are being used to sell a product unrelated to VEX. Examples of acceptable use would be local team recruitment, fundraising, or team apparel.

Since this request is for school purposes, you definitely fall under our acceptable use guidelines, but feel free to contact support@vex.com if you would like feedback or final approval before printing.

Thank you,
Lindsey

Lindsey Gideon
Director of Corporate Communications
VEX Robotics, Inc.
lindsey@vex.com
903-453-0858 (office)

Figure 3.2.5.B

http://commons.wikimedia.org/wiki/File%3AH_bridge.svg

This file is licensed under the [Creative Commons Attribution-Share Alike 3.0 Unported](#) license.

You are free:

- **to share** – to copy, distribute and transmit the work
- **to remix** – to adapt the work

Under the following conditions:

- **attribution** – You must attribute the work in the manner specified by the author or licensor (but not in any way that suggests that they endorse you or your use of the work).
- **share alike** – If you alter, transform, or build upon this work, you may distribute the resulting work only under the same or similar license to this one.

 CC BY SA
SOME RIGHTS RESERVED

This licensing tag was added to this file as part of the [GFDL licensing update](#).

Figure 3.2.6.A

<http://developer.android.com/about/dashboards/index.html> - Accessed November 2014

No changes were made to the image.

You are free to:

Share — copy and redistribute the material in any medium or format

Adapt — remix, transform, and build upon the material

for any purpose, even commercially.

The licensor cannot revoke these freedoms as long as you follow the license terms.

Under the following terms:



Attribution — You must give **appropriate credit**, provide a link to the license, and **indicate if changes were made**. You may do so in any reasonable manner, but not in any way that suggests the licensor endorses you or your use.

No additional restrictions — You may not apply legal terms or **technological measures** that legally restrict others from doing anything the license permits.

Figure 3.2.13.A

<http://www.ti.com/lit/an/snva533/snva533.pdf>

Reproduction of TI information in TI data books or data sheets is permissible only if reproduction is without alteration and is accompanied by all associated warranties, conditions, limitations, and notices. Reproduction of this information with alteration is an unfair and deceptive business practice. TI is not responsible or liable for such altered documentation. Information of third parties may be subject to additional restrictions.

Figure 3.2.15.A

<http://www.solarenergyexplorer.com/maximum-power-point-tracking.html>

Please note that all fields followed by an asterisk must be filled in.

First Name*

E-Mail Address*

Street Address*

Country*

Subject*

Your Queries or Feedback*

Please enter the word that you see below.

cobalt

Figure 3.2.16.A

<http://www.mpoweruk.com/performance.htm>



Tue 11/25/2014 10:16 AM

Barrie Lawson <bfl@woodbank.com>

RE: Permission to use your temperature characteristics graph

To 'Adrian Morgan'

Adrian

Thank you for your email.

Yes you may use any information from the Electropaedia web site so long as you accompany it with an acknowledgement of the source, by means of a link to the site.

Thank you for your interest in the Electropaedia.

Good luck with your presentation

Barrie Lawson

From: Adrian Morgan [<mailto:amorgan18@knights.ucf.edu>]

Sent: 25 November 2014 06:36

To: office@woodbank.com

Subject: Permission to use your temperature characteristics graph

My name is Adrian Morgan and I'm a student at the University of Central Florida. I'm currently in senior design and I wanted to ask permission to use your graph on the temperature characteristics of lithium ion batteries (voltage vs discharge time.) It will be used by my group for our documentation.

Thank you,
Adrian

Figure 3.2.16.B

http://www.eetimes.com/document.asp?doc_id=1225958



Tue 11/25/2014 7:59 PM

Adrian Morgan

Permission to use your CC/CV charging cycle graph

To 'Khosrow.Khy.Vijeh@nsc.com'

My name is Adrian Morgan and I'm a student at the University of Central Florida. I'm currently in senior design and I wanted to ask you permission to use your graph on CC/CV charging cycle for lithium ion batteries. It will be used by my group for our documentation.

Thank you,
Adrian

Figure 3.2.17.A

<http://dev.emcelettronica.com/introduction-to-switching-regulators>



Tue 11/25/2014 8:12 PM

Adrian Morgan

Permission to use figure on voltage regulator basics

To 'info@emcelettronica.com'

My name is Adrian Morgan and I'm a student at the University of Central Florida. I'm currently in senior design and I wanted to ask you permission to use your figure on the basics of how voltage regulators operate. It will be used by my group for our documentation.

Thank you,
Adrian

Figure 4.7.3.A

<http://www.ti.com/lit/ds/symlink/bq24650.pdf>

Reproduction of TI information in TI data books or data sheets is permissible only if reproduction is without alteration and is accompanied by all associated warranties, conditions, limitations, and notices. Reproduction of this information with alteration is an unfair and deceptive business practice. TI is not responsible or liable for such altered documentation. Information of third parties may be subject to additional restrictions.

Figure 4.7.3.B

<http://www.ti.com/lit/ds/symlink/bq24650.pdf>

Reproduction of TI information in TI data books or data sheets is permissible only if reproduction is without alteration and is accompanied by all associated warranties, conditions, limitations, and notices. Reproduction of this information with alteration is an unfair and deceptive business practice. TI is not responsible or liable for such altered documentation. Information of third parties may be subject to additional restrictions.

Figure 4.7.4.A

Created using TI's Webench.

Reproduction of significant portions of TI information in TI data books, data sheets or WEBENCH designs is permissible only if reproduction is without alteration and is accompanied by all associated warranties, conditions, limitations, and notices. TI is not responsible or liable for such altered documentation. Information of third parties may be subject to additional restrictions.

Figure 4.7.4.B

Created using TI's Webench.

Reproduction of significant portions of TI information in TI data books, data sheets or WEBENCH designs is permissible only if reproduction is without alteration and is accompanied by all associated warranties, conditions, limitations, and notices. TI is not responsible or liable for such altered documentation. Information of third parties may be subject to additional restrictions.

Figure 4.7.4.C

Created using TI's Webench.

Reproduction of significant portions of TI information in TI data books, data sheets or WEBENCH designs is permissible only if reproduction is without alteration and is accompanied by all associated warranties, conditions, limitations, and notices. TI is not responsible or liable for such altered documentation. Information of third parties may be subject to additional restrictions.

Figure 4.7.4.D

Created using TI's Webench.

Reproduction of significant portions of TI information in TI data books, data sheets or WEBENCH designs is permissible only if reproduction is without alteration and is accompanied by all associated warranties, conditions, limitations, and notices. TI is not responsible or liable for such altered documentation. Information of third parties may be subject to additional restrictions.

Figure 5.1.6.A

<http://www.electroschematics.com/wp-content/uploads/2013/07/HCSR04-datasheet-version-1.pdf>



wongj92
Tue 11/11/2014 1:45 PM

Mark as unread

To: services@elecfraks.com;

Greetings,

My name is Jimmy, and I am a senior at the University of Central Florida. I would like to ask for permission to use product images and product datasheets from your website in a design document for my Senior Design coursework.

Thank you,
Jimmy Wong



support@elecfraks.com
Mon 11/17/2014 8:32 AM

Mark as unread

To: wongj92;

Cc: wang.robi <wang.robi@elecfraks.com>;

Action Items

+ Get more apps

Dear Jimmy

Thanks for your attention our product, Yes, you can use our product datasheets design your work, You can specify source if you can, if you have any problem, please let me know.

Best Regards

Dragon

support@elecfraks.com

Figure 5.1.6.B

<https://www.sparkfun.com/datasheets/Components/GP2Y0A21YK.pdf>



wongj92

Tue 11/11/2014 1:38 PM

Mark as unread

To: smawebmaster@sharpsec.com;

Greetings,

My name is Jimmy, and I am a senior at the University of Central Florida. I would like to ask for permission to use product datasheets images and information for your IR sensors in a design document for my Senior Design coursework.

Thank you,
Jimmy Wong



Lavallee, Don <LavalleeD@sharpsec.com>

Tue 11/11/2014 1:41 PM

Inbox

Mark as read

To: wongj92 <wongj92@knights.ucf.edu>;

Action Items

+ Get more apps

The information on our public web site may be used for your coursework. Thanks for asking.

Regards,

Don LaVallee

Director - Strategic Business Operations

Sharp Microelectronics of the Americas

1.360.834.8089 office | 1.360.773.5372 mobile | 1.360.834.8653 fax

lavalleed@sharpsec.com

Figure 5.1.10.A

<http://www.pololu.com/product/1566>



wongj92

Tue 11/11/2014 1:21 PM

Mark as unread

To: support@pololu.com;

Greetings,

My name is Jimmy, and I am a senior at the University of Central Florida. I would like to ask for permission to use product images from your website in a design document for my Senior Design coursework.

Thank you,
Jimmy Wong

Appendix B - Works Cited

Tanenbaum, Andrew S., and D. Wetherall. *Computer Networks*. 5th ed. Boston: Pearson Prentice Hall, 2011. Print.

Franklin, Curt, and Julia Layton. "How Bluetooth Works" 28 June 2000. HowStuffWorks.com. <<http://www.howstuffworks.com/bluetooth.htm>>.

Paul, Ian. "Wi-Fi Direct vs. Bluetooth 4.0: A Battle for Supremacy." *PCWorld*. N.p., 26 Oct. 2010. Web. <<http://www.pcworld.com/article/208778/Wi-Fi-Direct-vs-Bluetooth-4-0-A-Battle-for-Supremacy.html>>.

Brain, Marshall, Tracy V. Wilson and Bernadette Johnson. "How WiFi Works" 30 April 2001. HowStuffWorks.com. <<http://computer.howstuffworks.com/wireless-network.htm>>.

"BRUSHLESS VS BRUSHED MOTORS." *Brushless vs Brushed Motors*. SL-MTI, n.d. Web. <<http://www.dynetic.com/brushless%20vs%20brushed.htm>>.

"The Handy Board." *The Handy Board*. N.p., n.d. Web. <<http://handyboard.com/hb/faq/hardware-faqs/dc-vs-servo/>>.

Igoe, Tom. "ITP Physical Computing." *ITP Physical Computing*. N.p., 31 Aug. 2014. Web. <<http://itp.nyu.edu/physcomp/labs/motors-and-transistors/dc-motor-control-using-an-h-bridge/>>.

Tantos, Andras. "Modular Circuits." *Modular Circuits*. N.p., n.d. Web. <<http://www.modularcircuits.com/blog/articles/h-bridge-secrets/h-bridges-the-basics/>>.

"Proximity Sensors - Engineers' Handbook." *Proximity Sensors*. Engineers' Handbook, n.d. Web. <<http://www.engineershandbook.com/Components/proximitysensors.htm>>.

Dawson, Brett. "Understanding Gear Reduction." *Understanding Gear Reduction*. Team DaVinci Robotics, n.d. Web. <http://www.teamdavinci.com/understanding_gear_reduction.htm>.

"Amorphous Silicon Solar Cells: Solar Facts and Advice." *Amorphous Silicon Solar Cells: Solar Facts and Advice*. N.p., n.d. Web. <<http://www.solar-facts-and-advice.com/amorphous-silicon.html>>.

"Basic Linear Voltage Regulator Guide." – *Dangerous Prototypes*. N.p., n.d. Web. <http://dangerousprototypes.com/docs/Basic_linear_voltage_regulator_guide>.

"Battery and Energy Technologies." *Battery Performance Characteristics*. N.p., n.d. Web. <<http://www.mpoweruk.com/performance.htm>>.

"Battery Capacity." *Battery Capacity*. N.p., n.d. Web.

<<http://pvcdrom.pveducation.org/BATTERY/capacity.htm>>.

Bernard, Murrye. "Pros and Cons of Wind Energy." *LoveToKnow*. N.p., n.d. Web. <http://greenliving.lovetoknow.com/Pros_and_Cons_of_Wind_Energy>.

Burris, Matthew. "Lithium-Ion Battery Safety." *About*. N.p., n.d. Web. <<http://components.about.com/od/Components/a/Liionsafety.htm>>.

Calvert, J. B. "Switching Regulator." *Switching Regulator*. N.p., 8 June 2008. Web. <<http://mysite.du.edu/~etuttle/electron/elect63.htm>>.

"Charging Lithium-Ion Batteries." – *Battery University*. N.p., n.d. Web. <http://batteryuniversity.com/learn/article/charging_lithium_ion_batteries>.

"Common Sense RC." *Common Sense RC*. N.p., n.d. Web. <https://www.commonsenserc.com/page.php?page=c_ratings_explained.html>.

"The Different Types of Rechargeable Battery." *Battery Force Blog*. N.p., n.d. Web. <<http://blog.battery-force.co.uk/battery-news/the-different-types-of-rechargeable-battery/>>.

Evanczuk, Stephen, and Hearst Electronic Products. "Designing a High-Efficiency Solar Power Battery Charger." *DigiKey Electronics*. N.p., 10 Dec. 2011. <<http://www.digikey.com/en/articles/techzone/2011/oct/designing-a-high-efficiency-solar-power-battery-charger>>.

Fried, Limor. "USB, DC & Solar Lipoly Charger." *Design Notes*. N.p., n.d. Web. <<https://learn.adafruit.com/usb-dc-and-solar-lipoly-charger/design-notes>>.

Ionela. "Introduction to Switching Regulators | Your Electronics Open Source." *Elettronica Open Source*. N.p., 15 May 2009. Web. <<http://dev.emcelettronica.com/introduction-to-switching-regulators>>.

Keeping, Steven, and Hearst Electronic Products. "A Designer's Guide to Lithium Battery Charging." *A Designers Guide to Lithium Battery Charging*. N.p., 25 Sept. 2012. Web. <<http://www.digikey.com/en/articles/techzone/2012/sep/a-designers-guide-to-lithium-battery-charging>>.

Keeping, Steven. "Understanding the Advantages and Disadvantages of Linear Regulators." *DigiKey Electronics*. N.p., 5 Aug. 2012. Web. <<http://www.digikey.com/en/articles/techzone/2012/may/understanding-the-advantages-and-disadvantages-of-linear-regulators>>.

"Lithium Polymer Battery Pack, Lithium Polymer Cell, Li Po Cell, Li Po Battery, Protection Circuit." *Lithium Polymer Battery Pack, Lithium Polymer Cell, Li Po Cell, Li Po Battery, Protection Circuit*. N.p., n.d. Web. <http://www.ibtpower.com/Battery_packs/Li_Polymer/Lithium_polymer_tech.html>.

Maehlum, Mathias A. "Which Solar Panel Type Is Best? Mono-, Polycrystalline or Thin Film?" *Energy Informative*. N.p., n.d. Web. <<http://energyinformative.org/best-solar-panel-monocrystalline-polycrystalline-thin-film/#building-integrated-photovoltaics>>.

Martell, Mike. "Switching Regulator Basics." *Switching Regulator Basics*. N.p., n.d. Web. <<http://www.rason.org/Projects/swregdes/swregdes.htm>>.

Mit Electric Vehicle Team, December 2008. *A Guide to Understanding Battery Specifications* (n.d.): n. pag. Web. 10 Oct. 2014.

"Multicopter Build Log." *Multicopter Build Log*. N.p., n.d. Web. <http://multicopter.forestblue.nl/lipo_need_calculator.html>.

"Northern Arizona Wind & Sun." *What Is Maximum Power Point Tracking (MPPT)*. N.p., n.d. Web. <<http://www.solar-electric.com/mppt-solar-charge-controllers.html>>.

Patankar, Chaitanya. "Maximum Power Point Tracking - MPPT." *Solar Energy Explorer*. N.p., n.d. Web. <<http://www.solarenergyexplorer.com/maximum-power-point-tracking.html>>.

"Renewable & Non-Renewable Energy Sources - Conserve Energy Future." *ConserveEnergyFuture*. N.p., n.d. Web. <<http://www.conserve-energy-future.com/>>.

"REUK.co.uk - The Renewable Energy Website." *Zener Diode Voltage Regulator*. N.p., 24 Sept. 2014. Web. <<http://www.reuk.co.uk/Zener-Diode-Voltage-Regulator.htm>>.

Scansen, Don. "Charge Controller Design for Maximum Battery Lifetime in PV Systems." *DigiKey Electronics*. Hearst Electronic Products, 9 May 2012. Web. <<http://www.digikey.com/en/articles/techzone/2012/sep/charge-controller-design-for-maximum-battery-lifetime-in-pv-systems>>.

"Standard Test Conditions (STC) vs. Normal Operating Cell Temperature (NOCT)." *Standard Test Conditions (STC) vs. Normal Operating Cell Temperature (NOCT)*. N.p., n.d. Web. <http://www.amsolar.com/home/amr/page_164>.

"Understanding RC LiPo Batteries." *RCHelicopterFun.com*. N.p., n.d. Web. <<http://www.rchelicopterfun.com/rc-lipo-batteries.html>>.

Vijeh, Khosrow K. "Current, Voltage and Temperature Govern Li-Ion Battery Charging - Part 2 | EE Times." *EETimes*. N.p., 28 May 2003. Web. <http://www.eetimes.com/document.asp?doc_id=1225958>.

"What's the Best Battery?" *Advantages and Limitations of the Different Types of Batteries*. N.p., n.d. Web. <http://batteryuniversity.com/learn/article/whats_the_best_battery>.

"Zener Diode as Voltage Regulator Tutorial." *Basic Electronics Tutorials*. N.p., n.d. Web. <http://www.electronics-tutorials.ws/diode/diode_7.html>.