

Optical Supplemental Navigation Device (OSN)



The University of Central Florida
College of Optics and Photonics (CREOL) and Department of
Electrical Engineering
Dr. Lei Wei and Dr. Hagan

Group 24

Wilfredo Ortiz | Photonic Science and Engineering
Joseph Devenport | Photonic Science and Engineering
Cedric Harper | Electrical Engineering
Henry Schmitz | Electrical Engineering

Table of Contents

1.0. Executive Summary	1
2.0. Project Description	2
2.1. Motivation	2
2.2. Specifications	3
2.3. Engineering and Marketing Requirements	5
3.0. Research	6
3.1. Current Technologies	6
3.2. Rangefinder Types	12
3.2.1. Ultrasonic	12
3.2.2. Laser	13
3.3. Range Finding Methods.....	13
3.3.1. Interferometry	13
3.3.2. Triangulation.....	14
3.3.3. Time of Flight.....	15
3.4. Components	16
3.4.1. Transmitter	16
3.4.1.1. Light Sources.....	17
3.4.1.2. LEDs or Laser Diodes	17
3.4.1.3. Laser Diodes.....	20
3.4.1.4. Laser Drivers	27
3.4.2. Receiver	27
3.4.2.1. Photodetectors	28
3.4.2.1.1. Photoresistor	28
3.4.2.1.2. Phototransistors.....	28
3.4.2.1.3. Photodiode	29
3.4.2.2. Operational Amplifiers	35
3.4.2.3. Optical Bandpass Filter.....	37
3.4.3. Power Management.....	38
3.4.3.1. Power Sources	39

3.4.3.1.1. Battery	39
3.4.3.1.1.1. Battery Types.....	40
3.4.4. Timing.....	45
3.4.4.1. Time-to-Digital Converter.....	48
3.4.4.2. Direct Down Conversion Receiver	52
3.4.5. Lenses.....	53
3.4.5.1. Types of lenses	54
3.4.5.2. Collimating laser light.....	55
3.4.5.3. Lens modeling	56
3.4.6. Haptic Feedback.....	57
3.4.6.1. Vibration Motor	57
3.4.6.2. Haptic Driver	58
3.4.7. Microcontrollers	60
3.4.8. Software	64
3.4.8.1. C Vs. Assembly	65
3.4.9. Communication Protocol.....	66
3.4.9.1. Serial-Peripheral Interface	67
3.4.9.3. UART.....	69
3.4.10. Single Board Computer.....	70
4.0. Related Standards and Realistic Design Constraints	72
4.1. Standards Introduction.....	72
4.1.1. Related Standards.....	73
4.1.2. Design Influence of Relevant Standards.....	75
4.2. Realistic Design Constraints	76
4.2.1. Economic and Time constraints	76
5.0. Design	77
5.1. Device Operation.....	77
5.2. Power	78
5.3. Hardware.....	79
5.3.1 MSP430 Low Power Modes.....	80
5.3.2 Pin-to-Buzzer Feedback Design	81
5.4. Software	81
5.4.1. Polling Vs. Interrupts.....	82

5.4.2. Pin-to-Buzzer Feedback Software Design	84
5.5. System Schematics	84
6.0. Build	93
6.1. Bill of Materials	93
6.2. Summary of Parts	98
7.0 Prototype Testing	103
7.1. Testing Environment.....	103
7.2. Safety Procedures	104
7.3. Hardware Testing	105
8.0. Administrative Content	117
8.1. Timeline.....	117
8.2. Budget.....	119
8.3. Version Control.....	120
9. Conclusion.....	121
Appendices	I
Appendix A - Copyright Permissions	I
Appendix B - References.....	VIII

Table of Tables

Tables	Table Description
2.2	Project Specifications
2.3	Engineering/Marketing Trade-off Matrix
3.2.1	Ultrasonic Pros/Cons
3.2.2	Laser Pros/Cons
3.4.3.1.1	Battery Comparison
3.4.7.1-1	Comparison of Microcontrollers Considered
3.4.8.1-1	Comparison of C Vs Assembly
3.4.10	Comparison of Single Board Computers
6.1-1	Bill of Materials (Transmitter)
6.1-2	Bill of Materials (Receiver)
6.1-3	Bill of Materials (Timing)
6.1-4	Bill of Materials (Processing and Power)
6.1-5	Bill of Materials (Haptic Feedback)
6.2-1	SFH2701 Parameters
6.2-2	S2381 APD Parameters
8.1	Timeline
8.2	Budget

Table of Figures

Figures	Figure Description
3.1-1	Ultra-Cane
3.1-2	iGlasses
3.1-3	Hand-Mounted Rangefinder
3.1-4	BrainPort V100 Image Display
3.1-5	BrainPort V100 Headset
3.3.1	Michelson Interferometer
3.3.2	Rangefinder Triangulation Method
3.3.3	Time of Flight Method
3.4.1.2-1	Signal-to-Noise Ratio Concept
3.4.1.2-2	Spontaneous vs Stimulated Emission Drive Current vs Output Power
3.4.1.2-3	Laser Diode Modulation Response
3.4.1.3-1	Distributed Bragg Rangefinder
3.4.1.3-2	Distributed Feedback Laser Diode
3.4.1.3-3	External Cavity Laser
3.4.1.3-4	MEMS-Tunable VCSEL Diagram
3.4.1.3-5	Quantum Well Simplified Diagram
3.4.1.3-6	Desired Output Spectrum for SPL LL85 Laser Diode
3.4.1.3-7	Output Power Vs Voltage for SPL LL85 Laser Diode
3.4.1.4	Elantec EL7104C MOSFET Laser Driver
3.4.2.1.3-1	PN Junction Photodiode
3.4.2.1.3-2a	PIN Photodiode
3.4.2.1.3-2b	Avalanche Photodiode
3.4.2.2a	Operational Amplifier Diagram Pinout
3.4.2.2b	Operational Amplifier Diagram Schematic
3.4.2.3	NIR Bandpass Optical Filter Transmission Graph
3.4.3.1.1-1	Battery Schematic
3.4.3.1.1.1-1	Zinc Carbon Battery
3.4.3.1.1.1-2	Alkaline Battery
3.4.3.1.1.1-3	NiMH Battery
3.4.3.1.1.1-4	NiMH Battery Charge Curve

3.4.3.1.1.1-5	Lithium Ion Battery
3.4.4.1-1	TDC7200 Schematic
3.4.4.1-2	Time-to-Digital Conversion
3.4.4.1-3	Digital Delay Line Operating Principles
3.4.4.1-4	LIDAR Application Simplified Block Diagram
3.4.4.2	TRF371125 Block Diagram
3.4.5.1-1	Achromatic Cylinder
3.4.5.1-2	Acyylinder Lens
3.4.5.1-3	Axis Collimator Lens
3.4.5.1-4	High Performance Cylinder
3.4.5.2	Collimating Lens Laser Diagram
3.4.5.3	Beam Expander
3.4.6.2	Haptic Driver
3.4.7.1	TM4C123GH6PMI Block Diagram
3.4.9	Microcontroller/Peripheral Interface
3.4.9.1-1	SPI Master/Slave Interface
3.4.9.1-2	SPI Independent Slave Configuration
3.4.9.1-3	SPI Daisy-Chain Slave Configuration
3.4.9.2	UART Data Transmission Diagram
3.4.9.3	I2C Master/Slave Schematic
5.1	System Block Diagram
5.3-1	Voltage Divider (Ideal Resistor Values)
5.3-2	Voltage Divider (Realistic Resistor Values)
5.3.2	Proposed Feedback Buzzer Design
5.4.1-1	Polling Method Design
5.4.1-2	Interrupt Method Design
5.4.2	Pin - to - Buzzer Feedback Software Design
5.5-1	SPL LL_85 Laser Diode
5.5-2	Lens Design using Zemax Optics Studio
5.5-3	3D FFT Point Spread of Source Lens
5.5-4a	Newport KBX019 2D Ray Frame
5.5-4b	Newport KBX019 Spot Size Diagram
5.5-5a	Newport KBX013 2D Ray Frame

5.5-5b	Newport KBX013 Spot Size Diagram
5.5-6a	Seidel Diagram for Optical System
5.5-6b	Spot Diagram for Optical System
6.2	Summary of Parts
7.3-1	TDC 7200 EVM Hardware
7.3-2	DRV2605EVM-CT Hardware
7.3-3	Test Case for Long Distance
7.3-4	Test Case for Medium Distance
7.3-5	Test Case for Short Distance
7.3-6	Test Case for Photovoltaic Mode (left) and Photoconductive Mode (right)
7.3-7	Operational Amplifier Testing Schematic
7.3-8	SPL LL85 Testing Schematic
7.3-9	Output Optical Power Testing Schematic
7.3-10	Output Power vs Charge Voltage Theoretical Curve
7.3-11	Output Optical Power Testing Schematic (using spectrometer)

1.0. Executive Summary

The blind and visually impaired face different and unique challenges every day. One of these challenges includes navigating around rooms, buildings, and outdoor terrains, which may contain objects and boundaries unknown to the individual. Unknown objects pose a threat of tripping and even the possibility of injuries. The blind and visually impaired must navigate with caution in new areas as well as familiar ones. There is always a need to be cautious. Something, like a chair, could be moved and change even the most familiar settings. After talking to blind instructors at the Rehabilitation Center for the Blind and Visually Impaired about these challenges, we found out that they are interested in products that can make navigation faster and safer. They were very interested in something that can supplement what they currently use and that can remain cost effective. Currently, to help the blind, canes and guide dogs are both options to circumvent through these obstacles. A guide dog is highly beneficial for sensing the surroundings at a farther distance; however, there are still many things the dog cannot communicate to the individual.

Not everyone blind or visually impaired is fortunate enough to have a guide dog though. This can be either for reasons of price, care, or allergies. Canes, although very simple, are the standard aid for navigating. Canes do the job and are fairly affordable. They help the visually impaired through doorways or up a staircase. Although very useful, they still are limited to the length of the cane, which can average 41 to 46 inches. They can't aim the blind person in the direction of a door, which is one major benefit with the product we will design. Something as simple as this can help a blind person navigate through a building faster while remaining safe. Both the cane and guide dog are beneficial, but we see their limitations that we want to improve on. Adding on to this distance limitation can give a better understanding of surroundings and lead to the prevention of accidents and possible injuries.

2.0. Project Description

In the following sections will discuss details of our project. This includes the motive, specifications, and marketing requirements. Throughout this document we will refer to the technology to determine distance of objects as rangefinder and Lidar interchangeably. They can be assumed to mean the same thing.

2.1. Motivation

Our objective is not to create a new solution to the navigation for the blind and vision impaired. Rather, the objective of the group is to create a device that will supplement and improve upon the cane or guide dog by increasing their range. We see that the current technology works for the purpose it was meant to accomplish. But given the possibilities with current technology we will improve upon them. We will create a rangefinder that will sense objects or boundaries further outside the current range of a cane or guide dog. The device will use Lidar to detect the range of any object within a certain distance. The range of the object will be transformed to a signal on the individual wearing the device, which will tell him/her how far away the object is. This signals to the individual, that there is something in the way or an opening in a room, sooner than the cane or guide dog would, so they can react to the situation better. The response signal works by increasing or decreasing its signal frequency depending on the distance to an object. For instance, if the wearer gets closer to a wall the signal will speed up. To detect things, the individual will have to move the device aiming it, the same way a cane is used. This extra distance the device gives for detection will give the individual a bigger bubble of information and can help make the blind or visually impaired individual more confident with their surroundings. Sensing objects at a further distance out will allow them to move about at a faster pace and allow them to remain safe while doing so.

Partnership

For this project our team will be working with the Rehabilitation Center for the Blind and Visually Impaired out of Daytona Beach, FL. We will be in contact with Sr. Rehabilitation Specialist Jeff Malzow and Technology Instructor Joseph Carson. Working with the Rehabilitation Center will provide us with essential feedback as we build the device. They will relay to us the navigational problems blind and visually impaired deal with currently as well as critiques to our proposed solutions. This is essential, since we don't have the first-hand experience of being blind or visually impaired. We have come up with ideas that might sound good to us, but aren't practical or something they would even want. We will continue to take their recommendations and work with them throughout our design process.

2.2. Specifications

Overall Weight	Less than 10 pounds
Overall Size	Less than 8in by 5in
Overall Cost	Less than \$1000
Input power supply	Less than 12V
Laser Diode wavelength	Emits a wavelength between(600-1600nm)
Photodiode wavelength	Detects a wavelength between(600-1600nm)
Device Range	Up to 5 meters

Table 2.2 – Project Specifications

Microcontroller

The microcontroller must do the following:

- Operate between 1-5V
- Provide serial communication
- Have at least 30 general purpose I/O pins
- Have programmable low-power modes
- Have low power consumption in sleep mode
- Have fast wake up time
- Ability to disable peripherals
- Have peripherals capable of operating in sleep mode
- Allow interrupts
- Have a high clock frequency (~16MHz or higher)

The microcontroller will serve as the control unit of the entire project. It is tasked with monitoring the input and output LIDAR signals. It is responsible for reading the signal and interpreting the distance of the object. It is also responsible for controlling the vibration motor frequency in determining the proximity of the object. It would be tasked with, more importantly, power management.

Single Board Computer

- Operate between 1-5V
- Provide at least 16MHz frequency
- Have at least 1 UART pin
- Have at least 30 general purpose I/O pins
- Have at least 5KB or RAM

The single board computer acts as an extension of the microcontroller. It contains the microcontroller and peripherals that can be used to communicate with both the microcontroller and the external devices. It is imperative that the SBC of choice has sufficient power and peripherals needed.

Power Source

The power source must do the following:

- Provide up to 9V(maximum) power
- Be significantly small in size (< 5in)
- Be relatively lightweight (< ½ lb)
- Be of high quality (material & build)

The power source would come in the form of a battery. This particular battery will need to be of high-quality material due to the number of objects the battery would be responsible of powering. Since all of the connected objects will be drawing current (though a very small amount), it is ideal to have a battery that provides a voltage on the higher end of the specifications. However, if a battery of higher quality is able to power the system at a lower voltage, it will be used.

2.3. Engineering and Marketing Requirements

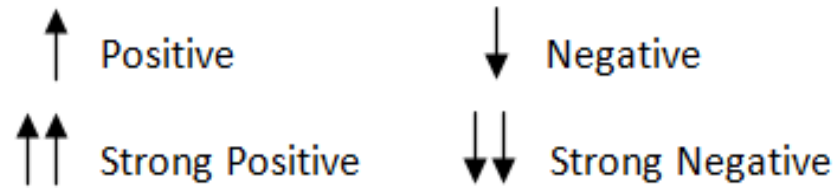

		Output power	Cost	Dimensions	Weight	Quality	Install Time
		+	-	-	-	+	-
Accuracy	+	↑	↑↑	↑		↑	↓
Cost	-	↑	↑↑	↑		↑↑	↓
Low Power	+	↑↑	↑				↑
Usability	+			↓	↓↓	↑	↓
Portability	+	↓↓	↑	↓↓	↓↓	↓	↓
Engineering Requirement Targets		<1 Watt	<\$1000	<8in by 5in	<10lbs	>50%	<7days

Table 2.3 – Engineering/Marketing Trade-Off Matrix

3.0. Research

This section will look at the different topics required to create a lidar rangefinder. First we look at the current technologies. Some of the technologies are very similar to ours in that they used lidar, however the products and ideas are not exactly in line with what we have set out to accomplish. Other similar technologies were then researched that produce the same result, however use other technologies other than lidar to produce the same result. Some of these technologies researched are already products on the market, while others are projects that have been designed like ours will be. Along with this research, we looked into all the different types and methods of range finding. We took a look at Ultrasonic and laser technology. We also learned about interferometry, triangulation, and time-of-flight methods.

3.1. Current Technologies

There are other products on the market designed to solve this same problem. The problems with these are they are either bulky, expensive, or can be considered too complicated. Some might require an Internet connection. We are more focused on providing a product that is low cost, easy to use, and lightweight. We think this can help to reach a wider audience. The simplicity is what makes it attractive to the marketplace. For instance a heavy system such as a vest can work, however over time it could fatigue the user. Just like most technology now we want to provide a solution that is small and lightweight. The learning curve should also be short. The user will already be comfortable using their cane or guide dog. The smaller system should help lower the cost, which is ideal for this product.

We aren't the first to think of using laser technology to help the blind and visually impaired. Although canes and service dogs have been great solutions to the challenges of the vision impaired, new technology has been developed, and is continuing to be developed to improve upon these solutions. There are several other products already out on the market today to supplement existing technology. We have found out that there is not as much technology being developed using lasers, but mostly the technology used is dealing with ultrasonic radiation.

One such product leading the way in this technology is the UltraCane. Similar to our idea, the UltraCane adds on to the already proven cane giving the user additional feedback with his/her surroundings. They state that it gives additional protection at the head/chest height of the user. Using two sensors the UltraCane sends out ultrasonic waves, which are able to capture obstacles within two to four meters. Just like our design, the UltraCane uses vibration for the haptic feedback on the handle. The haptic feedback on the UltraCane vibrates with two

buttons to indicate direction and alters frequency to notify distance. The user sets one of the two ranges. Short range detects objects at two meters, while the long range detects four meters. In addition an upper transducer detects objects at an upward angle of up to 1.6 meters. The width of the detection beam is 0.8 meters.

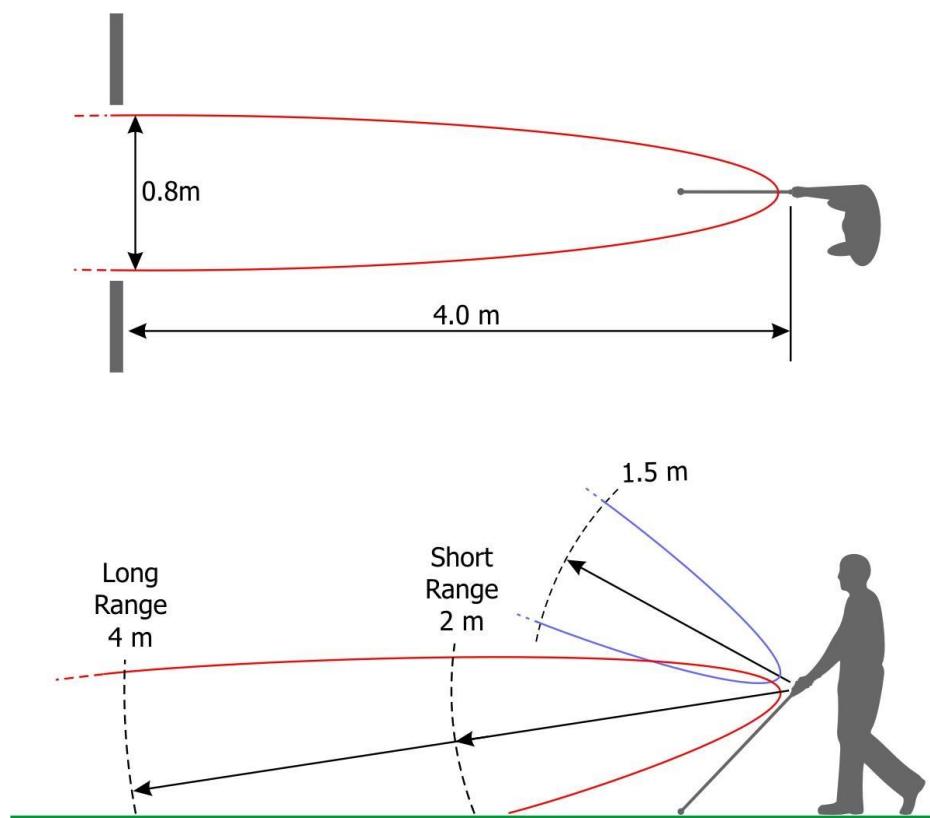

Figure 3.1-1 – Ultra Cane (permission requested)

The UltraCane helps the user recognize additional information in a room to help prevent potential dangers. Their goal is to help the blind or vision impaired be more confident and to safely, effectively navigate a room. The only downside of the UltraCane is that it might be overly expensive for some people, at around \$1,500.00.

Another product very similar to the UltraCane is the Smartcane. The Smartcane uses ultrasonic technology as well, however solely focuses on the obstacles above knee level. The direction the sensor is pointing can actually be adjusted to work for people of different heights. With a 1.8 to 3 meter range, the Smartcane adapts to the cane holders natural grip. Along with avoiding obstacles and possible injuries, reviews show users have actually reduced travel time because of better adaption to their surroundings. The cane can detect a 3-centimeter wide pipe at up to 3 meters in distance. The developers also designed the cane to have four distinct vibration patterns for haptic feedback. The device uses Li-ion batteries and can be recharged just like a cell phone without requiring

removing the batteries. Some additional features not shown on the UltraCane are feedback to let the user know the batteries are low, the detection of fast objects, easy to attach/detach, multiple color options, able to withstand an accidental fall, water resistant in light rain, and it conforms to international quality standards. The Smartcane is sold online at a price over \$3000 dollars.

A different look at the solution is delivered with iGlasses. iGlasses uses ultrasonic technology also, however the sensor is attached to a pair of glasses. The haptic feedback is done with vibrations, which seems to be common with all of the products in this realm. As with the other products, this device is not used to replace the cane, but to supplement it. The frequency of vibrations increases the closer the user is to an object. The iGlasses are attached to a normal pair of glasses. To turn them on depress the power button and audible beeps will let the user know that it is turned on. The device also uses audible signals to let the user know how much battery is left. Since having the vibrations on the user's head can be preferred at different intensities the makers of iGlasses created that option. The power supply used for the iGlasses is a 3.7 600mAh Li-ion rechargeable battery, which gives around a week of use. The device will charge in 2-3 hours. The range of the iGlasses will give you 0-3 meters detection. At \$96.10 this product is much easier to afford than the previous two examples. It would be a good option for blind and visually impaired individuals who don't mind scanning and getting feedback from glasses.

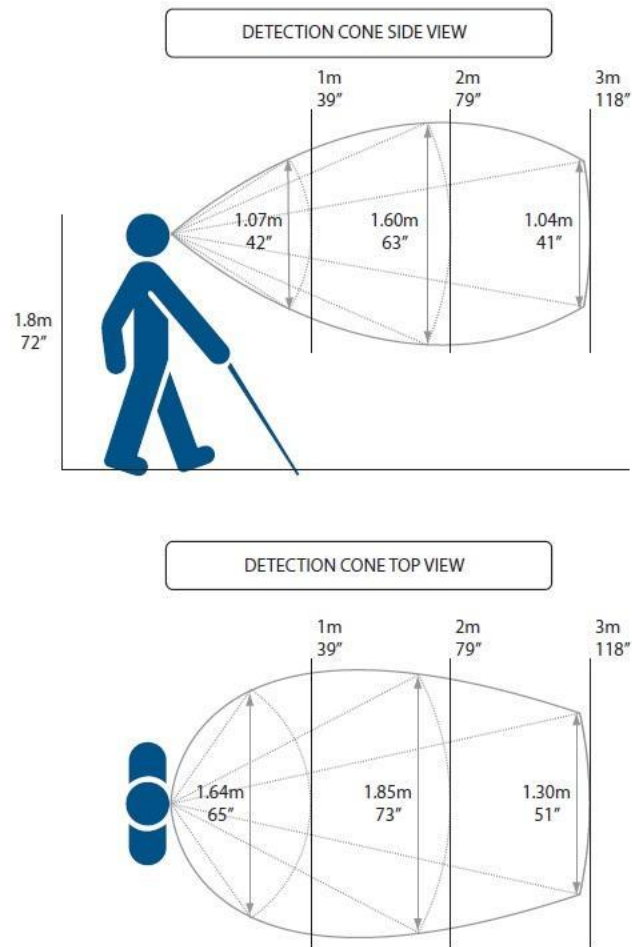

Detection ranges indicated are based on tests with a 110mm diameter object.

Figure 3.1-2 – iGlasses (permission requested)

Another alternative way of solving the problem is by designing the rangefinder sensor to be attached to the hand. In the future the cane could possibly become completely obsolete with an idea like this. At Grathio Labs, they have an open source model of this kind of a hand-mounted feedback called the Tacit Project. The only main difference from the other projects is that the user will be able to use their hand to sense objects in their surroundings by scanning back and forth. The project uses ultrasonic radiation to achieve responses in distances 2 cm to 3.5 m. The response time for feedback is fractions of a second. One real positive with having the device mounted on a hand is the ability to hold something else in that hand, or just to have a free hand available. This is just a prototype at Grathio Labs and would need to be refined for a final version for the

public. The same problem we face with what power source to use is something they mention. If they could use rechargeable batteries instead of the replaceable ones they currently have, the bulk of the device would be reduced significantly. They use a 9-volt battery, which we are considering to use. They also mention to work on making the rechargeable method blind friendly, which is important to think about in every aspect of our project. One important thing the designer brought up about vibrations from the motor is that if the device is too noisy then it can get in the way of audio feedback that a blind person uses and that a vibration that remains constant can cause nerve damage. For their project they went with small servomotors.

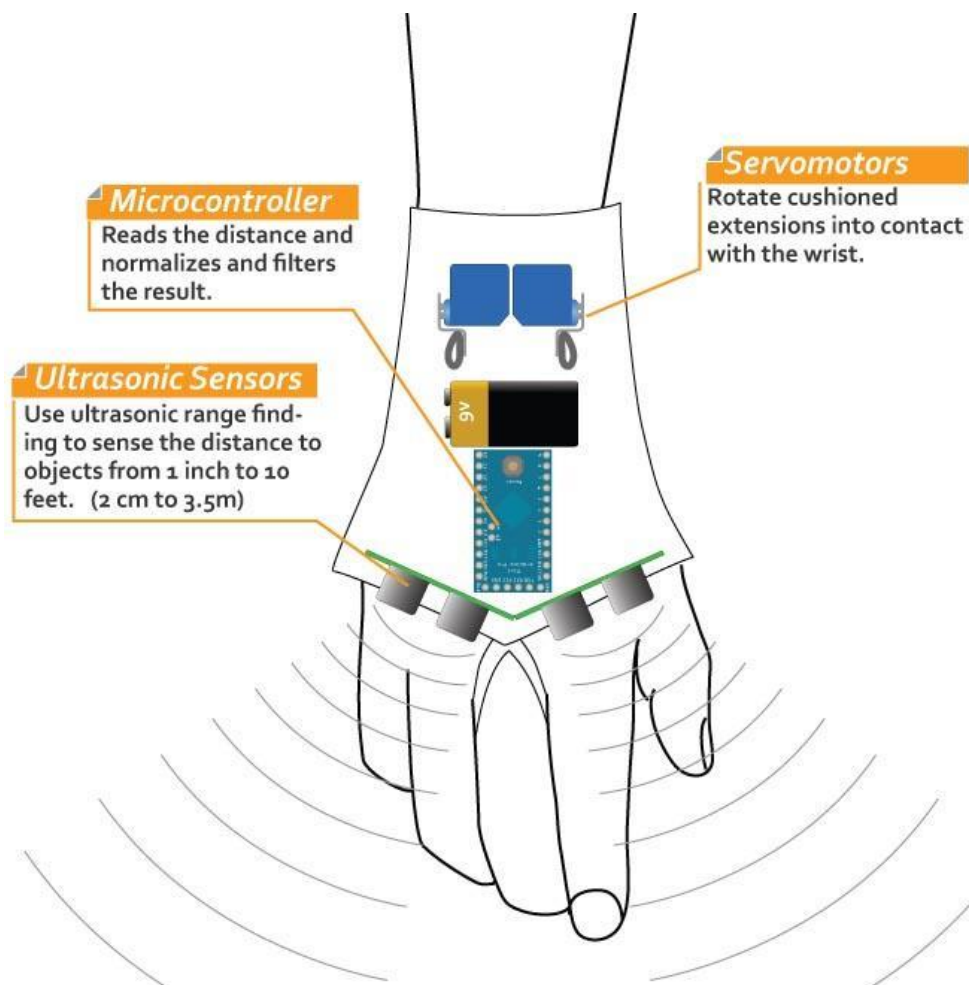

Figure 3.1-3 – Hand-Mounted Rangefinder (permission requested)

The difference between these other products is the technology used. These products on the market seem to focus on ultrasonic radiation to detect the surrounding objects. We are using a laser for the rangefinder, which should give us a more focused point to measure. The other point of these products we notice is the price. Although the products do a great job in helping blind and visually impaired navigate, the price might be too much for certain people in the market.

Our goal of making a cheaper more affordable rangefinder is aided by researching these other products and their prices.

Technology Today

Besides the use of ultrasonic and laser technology to assist the blind and visually impaired, more solutions are being discovered. At BrainPort Technologies, they are taking a completely different approach. Instead of just using a sensor to just detect distance, they try to create images in the blind person's head as an alternate way of seeing. This is classified as an oral electronic visual aid. Their product, the BrainPort V100 comes with sunglasses with a camera mounted on and a tongue array. The camera works in different lighting settings and has an adjustable field of view. On the tongue array there are 400 electrodes, which will stimulate the tongue making the user feel different pixels. Connected to the glasses with a cable, the camera will indicate white pixels as a strong stimulation on the tongue, gray pixels as a medium stimulation, and black pixels as no stimulation. With the proper training to the user, this stimulation will paint a picture of the objects and users surroundings in his/her mind.

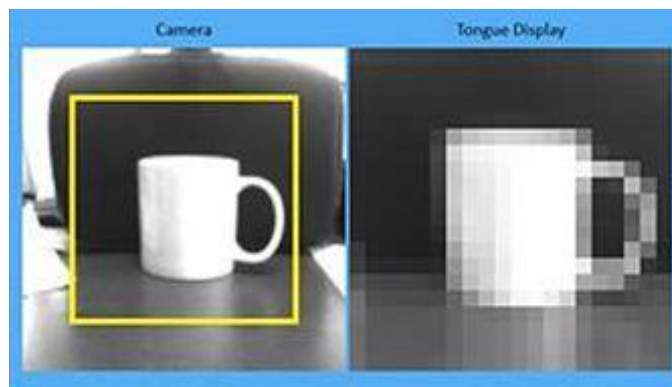

Figure 3.1-4 – BrainPort V1000 Image Display (permission requested)



Figure 3.1-5 – BrainPort V100 Headset (permission requested)

The technology coming out in the future will allow blind and visually impaired to do things they never thought they could. The majority of products right now are using ultrasonic technology, which are doing so fairly successfully but still with various limitations. Future technology looks to add on to this and possibly make it obsolete. As of now, it seems as though a combination of the technologies will supplement the blind and visually impaired best.

3.2. Rangefinder Types

There are many ways to determine the distance of an object. In the context of this project, we concerned only with noncontact range-finding since the target audience will most likely have some form of detecting objects with their cane or with a guide dog. Noncontact range-finding devices calculate the distance or 'range' from an observer to an object by projecting a signal using light or sound onto the object and processing the reflected signal.

Some methods of active range-finding include GPS, ultrasonic, and laser. Since the accuracy of a typical GPS rangefinder is much lower than ultrasonic and laser, it is automatically disqualified as an option for our project since we are aiming for an accuracy of within six inches. This leaves us with ultrasonic and laser as our choices. Listed below are the advantages and disadvantages of using each method. These are the determining factors of which method we will use.

3.2.1. Ultrasonic [1]

Pros	Cons
Inexpensive. A transceiver and receiver module can be found for about \$30	Small measuring range
Relatively small size and weight	High risk of error
Response is not affected by object's color or optical reflectivity	Low accuracy due to the difficulty of focusing sound
Can measure the distance of transparent objects such as the surface of water	Outside noise such as wind, traffic, and rain affects measurement as well as other environmental factors such as temperature
	Reliable sensing is determined by the surface area of the target provided that it is viewed squarely in order to receive a sufficient signal
	Objects with lower densities can absorb sound making them difficult to sense

Table 3.2.1 – Ultrasonic Pros/Cons

3.2.2. Laser [1]

Pros	Cons
Range – Laser rangefinders can measure distances over 1 kilometer	Can be expensive
Low power consumption	Requires steady hand for accurate results
Operation speed - Since the speed of light is faster than the speed of sound, the rangefinder can measure large distances in a short period of time	Line of sight to the object being measured has to be clear
Small spot size allows for high angular resolution	Atmospheric Scintillation can cause the laser beam to deflect the beam from the object being measured
Easy to use	

Table 3.2.2 – Laser Pros/Cons

There are several devices that use ultrasonic technology, but they are limited by too many factors. Since it uses sound to transmit and receive a signal, it would be impractical to use outside or in areas where there is a lot of noise. Another limitation is the spreading of the sound waves when they come out of the device. The purpose of the project is to help blind people navigate and for their safety, we want the device to be as precise as possible. Finally, the range of an ultrasonic device would be small. Although we are shooting for a relatively short distance for the navigation device, ultrasonic ranges are on the order of centimeters, far too short for this application. For this reason, measuring distance optically is the approach we are taking with this project.

3.3. Range Finding Methods

Optical methods using a laser for measuring distance can generally be divided into three different categories: interferometry, triangulation, and time-of-flight. While each one has different ways of being implemented, the following section will give a general overview of them all.

3.3.1. Interferometry

The first method, using interferometry, is the most accurate. Methods of interferometrically measuring distance have been shown to produce results with sub-millimeter resolution. Perhaps the most well-known type of interferometer is

the Michelson interferometer. The most basic setup consists of a light source, detector, beam splitter, and two mirrors (as seen in figure 3.3.1 below) – one on the reference arm and one on the sample arm. By detecting the delay of the sample arm one can determine the distance of an object. This method requires precise instruments and, because of the size and cost of the parts, would be impractical for this project.

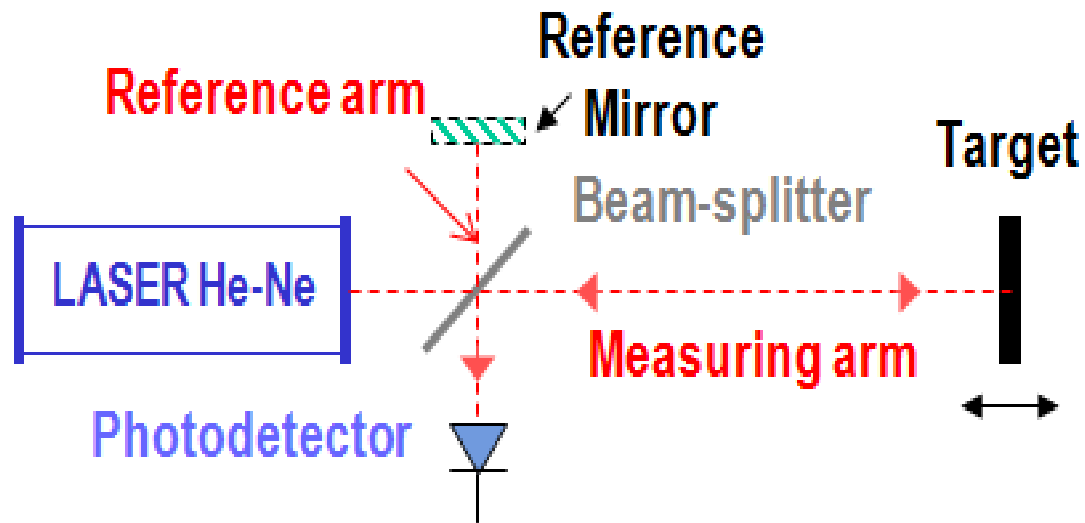

Figure 3.3.1- Michelson Interferometer (permission requested)

3.3.2. Triangulation

The triangulation method for determining distance is one of the oldest and most reliable. Also called the parallax method, it has been used by astronomers to measure the distance between stars and by surveyors to measure the distance of faraway objects. The name comes from the fact the emitted laser beam forms a triangle with the reflected light. Using this method, one can achieve a resolution of about one thousandth of the object distance.

The figure below shows a typical setup of a rangefinder using triangulation using a laser. The beam is collimated with a lens so as to keep the spot size of the beam small over large distances. The reflection of the light from the object is focused on to a detector a known distance away from the laser. The detector consists of a lens to focus the beam onto a charge couple device (CCD) chip, and the angle of the return signal is determined by the position of the light onto the CCD. With this information the distance can be calculated.

Although this method is very effective for measuring the distance of objects and would yield a very good resolution, triangulation via a point or line source requires that the object be still. Therefore, it is ineffective at measuring moving objects [59].

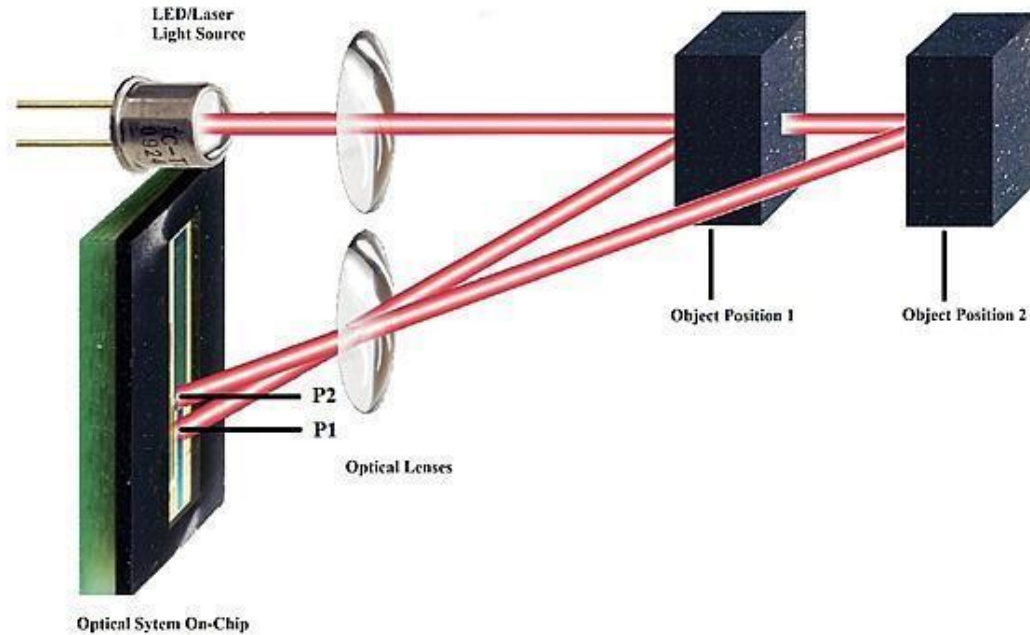

Figure 3.3.2 – Triangulation Method (permission requested)

3.3.3. Time of Flight

Time of flight (ToF), as the name suggests, is a very simple method that uses the time it takes a pulse of light to go from the device to the object and back to the detector to measure distance. This method makes use of a very simple formula:

$$2d = ct$$

Where c is the speed of light in a vacuum, t is that time it takes for the pulse to be sent out and return, and d is the distance. Since it is a round trip time, that calculation yields the value of twice the distance. In order to get an accurate measurement, the roundtrip time must be greater than the laser pulse width. The figure below (figure 3.3.3) shows a typical setup for a laser rangefinder using ToF as the method for measuring distance.

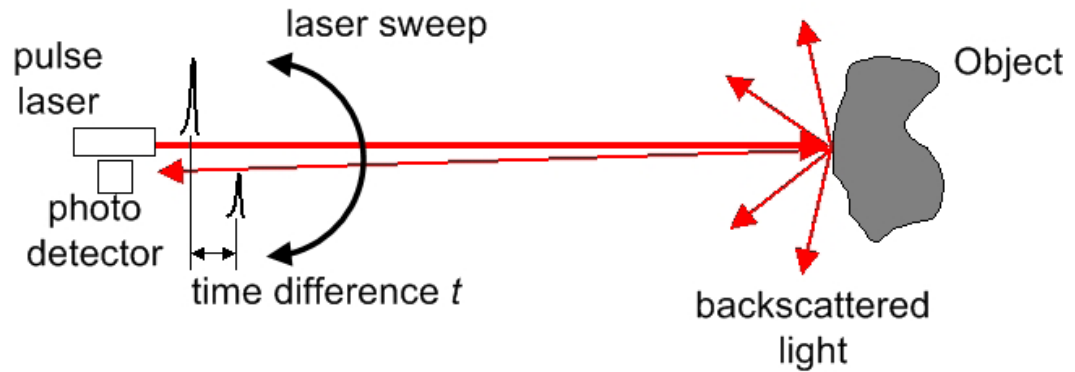

Figure 3.3.3– Time of Flight Method (permission requested)

While the equation to calculate the distance of an object is quite simple, the accuracy of the device is dependent on a couple factors. First, the pulses generated by the laser must be very small, about .5 ns to obtain a temporal resolution of 6 cm, and at a high repetition rate. The system must also measure accurately the clock time. One way to bypass using a high precision clock and a laser with short light pulses is by measuring the phase shift between emitted and received modulated light [59]. The new equation is calculated by demodulating the signal and cross-correlating the received signal with the emitted signal and is as follows:

$$d = \frac{c}{4\pi\omega} \phi$$

Where ω is the modulation frequency of the signal and ϕ is the phase shift. Since the objective of this project is to assist the blind in navigating through different environments, the time-of-flight method will be our method of choice due to its ability to yield good resolution and measurement of objects while the user is moving.

3.4. Components

The following section is dedicated to the explanation of components being researched for implementation of the project. The purpose of this is to come up with an idea on what components will be used in order to successfully construct the rangefinder. In this section, the group will compare and contrast different parts that will be considered for implementation. There are a number of ways to build the particular device. However, the idea is to come up with a list of components that will not only work, but will be efficient in power as well as cost. Since the device will be running without being connected to an infinite power source, such as a wall outlet, it is imperative that the group keeps in mind the number of constraints that come with this fact. The goal is to come up with a comprehensive list of materials that will be used to design, and eventually build said device.

3.4.1. Transmitter

The transmitter is one of the most important parts of this project. It dictates the range, the accuracy, and how safe the device will be. These are important when developing a product for the end-user.

3.4.1.1. Light Sources

This section details and compares certain light sources that are available in today's market. It is extremely important to specify certain performance specifications when choosing the right light source for implementing into our design. Factors such as output spectral width, device threshold current, and peak emission drift, to name a few, should all be considered when deciding on the right source to use.

3.4.1.2. LEDs or Laser Diodes

While the popularity of the LED is ever increasing, the needs of a particular product should be taken into consideration when selecting Lasers or LEDs. While a local dollar tree may boast of many LEDs, some focal points of the Laser diode should be noted.

Some say that “LEDs require less complex drive circuitry than laser diodes since no thermal or optical stabilization circuits are needed and they can be fabricated less expensively with higher yields” [31]. This is true for the most part but for certain applications, such as in ranging, laser diodes far outperform LEDs. Foremost, they outperform in spectral width. It is important for this application that a fairly monochromatic source of light be used and the smaller the spectral width, the better the chromaticity. This becomes important when you are dealing with pertinent factors in a ranging system such as signal to noise ratio (SNR). When considering signal to noise ratio in the case of a signal emitted from a source, a laser diode is of great benefit. This is because noise from the environment the system is placed in plays a role. Of course, if the source wavelength is exceedingly broad, as it is with an LED, it becomes increasingly difficult to differentiate between the desired signal to be detected and outside spectra noise. The figure below depicts the concept of the SNR. Notice the importance of differentiating signal from noise. Distinguishing between the signal and noise is paramount when dealing with low SNR.

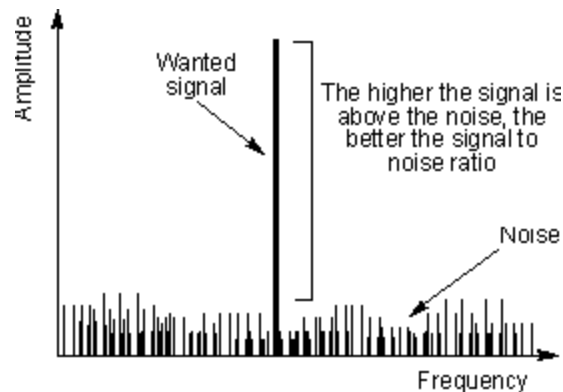

Figure 3.4.1.2-1 – Signal-to-Noise-Ratio Concept (permission requested)

Another factor to consider is the photodetector peak wavelength specifications. Say, for instance, the peak absorption wavelength for a photodetector is around 800nm. This means that the detector exhibits optimum performance when detecting source light at around 800nm and that performance is sacrificed when the detected light drifts from this wavelength. It then becomes vital to avoid using an LED as the source because rather than having output power specific to one wavelength (as in the case of a Laser Diode) the power is spread over a range of different wavelengths. This spread makes it difficult to accurately detect a weakened signal and such weakened signals are characteristic of the desired use in a light ranging device.

One should also consider the max optical power restrictions. The output power of this system must meet certain criteria in order to be considered eye safe. These criteria for output optical power even further augment the need to minimize source spread. The spectral width of LEDs at roughly 800 nm is around 36 nm, whereas that of laser diodes is around 2 nm [31]. In other words, there is about 18 times the spread in LEDs which lends to decreased precision when operation in a specific wavelength is required. This exaggerated spread is largely due to the fact that LEDs operate on spontaneous emission which results in emissions that “are isotropic and of random phase” [31]. On the other hand, lasers mostly emit via stimulated emission.

One benefit of using stimulated emission is that the “emitted photon is in phase with the incident photon [31].” This produces highly monochromatic and fixed-directional light. A relatively monochromatic (of one wavelength) source will allow not only allow for better performance in the area of detection but will also facilitate more useful concentration of output power. The figure below depicts an output power (in mW) versus drive current (in mA) curve that compares a spectrum dominated by spontaneous emission (as in the case of the LED) and a spectrum driven primarily by stimulated emission (as in the case of the laser).

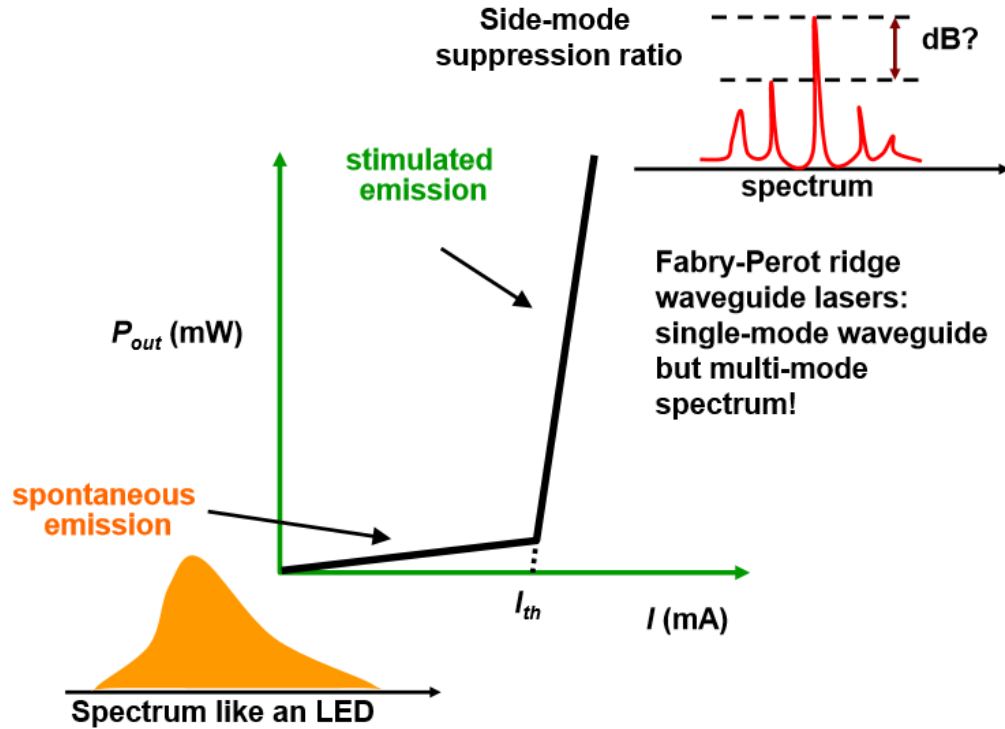

Figure 3.4.1.2-2 – Spontaneous vs Stimulated Emission Drive Current vs Output Power (Courtesy of S. Fathpour)

It should also be noted that the modulation response time is faster for laser diodes. “Laser diodes typically have response times of less than 1 nanosecond, and have optical bandwidths of 2 nm or less, and, in general, are capable of coupling several tens of milliwatts of useful luminescent power into optical fibers with small cores and small mode-field diameters.” [31]. The accelerated response time in laser diodes allows for a much higher modulation frequency. The following figure (below) provide a visual representation of this relation.

Transfer function:

$$H(\omega) = \frac{P(\omega)}{P(0)} = \frac{1}{1 + i\omega\tau}$$

ω : modulation frequency

$$f_{3dB} = \frac{\sqrt{3}}{2\pi\tau}$$

$\tau \sim 2-5$ ns
 $f_{3dB} \sim 50 - 140$ MHz

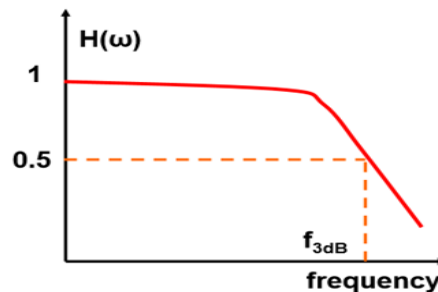

Figure 3.4.1.2-3 – Laser Diode Modulation Response (Courtesy of S. Fathpour)

3.4.1.3. Laser Diodes

Types of semiconductor lasers (LDs)

“There are a number of device structures that operate with an output spectrum that has high modal purity and hence a very narrow spectral width. Such LDs are often called single frequency lasers, even though it would be, in principle, impossible to get a perfect single frequency [30].”

Distributed Bragg Reflector LD

Distributed Bragg Reflector (DBR) lasers are capable of emitting a extremely narrow (some below the megahertz range) mode with notable (45dB) side mode suppression ratio (SMSR) [30]. DBR semiconductor lasers achieve narrow mode emission by implementing “. . . frequency selective dielectric mirrors at the cleaved surfaces of the semiconductor [30].” SMSR is a dB comparison between the peak emission wavelength and side modes (modes that deviate from the peak wavelength). Grating corrugation is crucial when designing these DBR lasers and should meet the condition for wave coupling at the Bragg wavelength, λ_B . This condition is realized as:

$$\lambda_B = \frac{2n\Lambda}{k}$$

In which n is the mode refractive index and k is grating order [31].

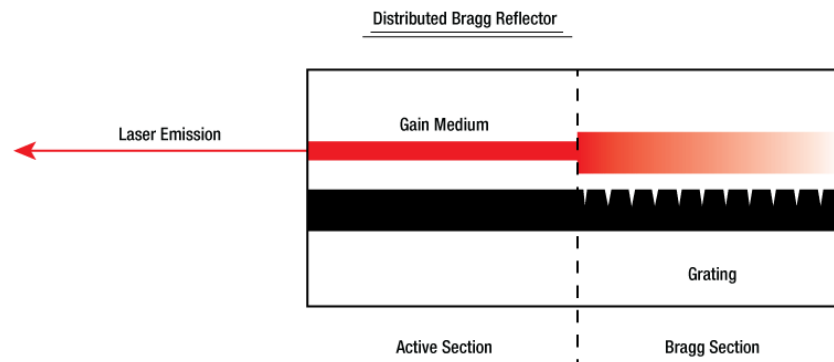

Figure 3.4.1.3-1 Distributed Bragg Rangefinder (permission requested)

Advantages of DBR lasers:

- Narrow emission band
- Moderately tunable
- High single mode suppression ratio

Disadvantages of DBR lasers:

- Susceptible to temperature variations
- Emphasized detail needed for fabrication

Distributed Feedback LDs

A distributed feedback (DFB) laser has its gratings over the entire active region instead of just at the ends of the normal active layer of the laser as in the case of the DBR laser [31]. Ideally, the laser's longitudinal modes are symmetrically divided around the Bragg wavelength. Realistically, factors such as asymmetry impede the simultaneous lasing of the zero order modes on either side of the lasing wavelength. In the case of the DFB laser, this asymmetry is welcomed and often intentionally increased (through the use of reflective coatings) because it ultimately makes way for single mode operation [31]. Although these lasers find their place in areas such as telecommunications and interferometry, "One technical drawback of using DFB LDs in instrumentation is the shift of the peak wavelength λ_0 with small changes in the temperature [30]." One partial solution is to integrate a temperature control device; however, a temperature controller is often too sluggish when attempting to deal with current changes encountered when modulating a DFB laser [30].

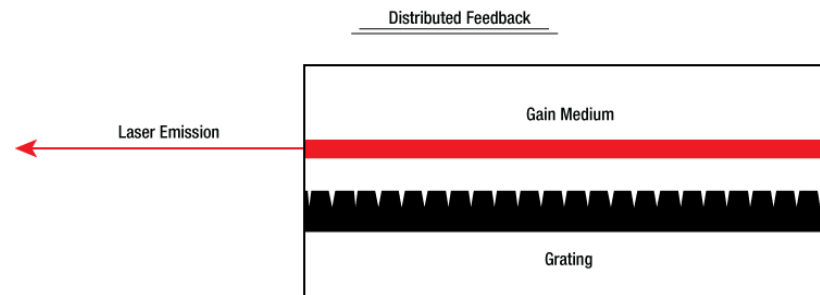

Figure 3.4.1.3-2 Distributed Feedback Laser Diode (permission requested)

Advantages of DFB lasers:

- Exceedingly narrow spectral width possible
- Tunable via temperature

Disadvantages of DFB lasers:

- Peak emission wavelength effected by small changes in temperature
- Emphasized detail needed for fabrication
- Experience frequency chirp when modulated by current

External Cavity LDs

External Cavity Laser diodes effectively compensate for frequency chirping and drift instability by housing their optical cavity outside the laser diode. This configuration allows for a lengthened optical path that does not suffer much from changes in refractive index that could normally result in a shift in the output wavelength (as is seen with DFB and DBR lasers). Although very beneficial, this lengthened cavity size means an increase in overall size. Also, this laser type requires that the light incident on the external optical resonator be collimated [30]. The figure below depicts one configuration for the External Cavity Laser referred to by some as a Littrow configuration ECDL [30].

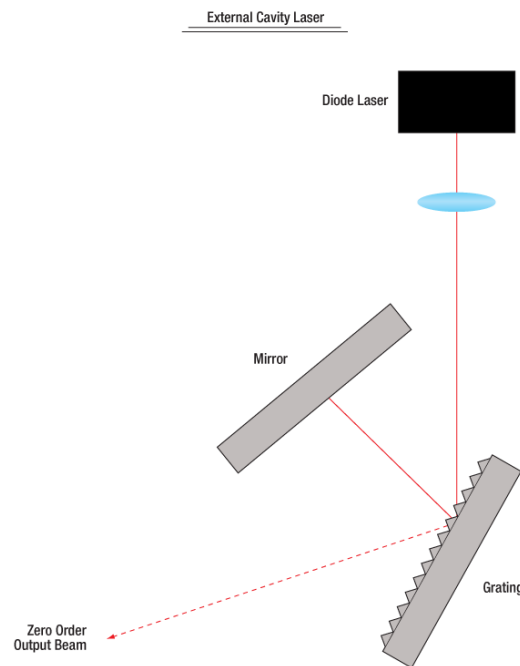

Figure 3.4.1.3-3 – External Cavity Laser (permission requested)

Advantages of External Cavity lasers:

- Immunity to frequency chirping
- Protection against drift
- Very narrow spectral width
- Tunable via filter or grating rotation
- Increased photon cavity lifetime

Disadvantages of External Cavity lasers:

- Bulky
- Require collimated incident light for interference filter configuration

Vertical Cavity Surface Emitting Lasers

The Vertical Cavity Surface Emitting Laser (VCSEL) makes use of two sets of Bragg reflectors. These reflectors have alternating (high and low) refractive indices as well as quarter wave spacing allowing for desired constructive interference. Proper characteristics of refractive index and layer thickness are represented in the equation below which is comparable to the Bragg wavelength condition.

$$n_1 d_1 + n_2 d_2 = \frac{\lambda}{2}$$

Where d_1 and d_2 are the thicknesses of the alternating layers and n_1 and n_2 are their associated indices, respectively [30].

Advantages of VCSELs

- Circular beam emitted
- Extremely small size capabilities
- Small spectral width
- Lower threshold current
- Lower operating current
- Capable of being arrayed to form a broad surface emitting laser source

Disadvantages of VCSELs

- Low emitted optical power
- Peak wavelength shifts with temperature change

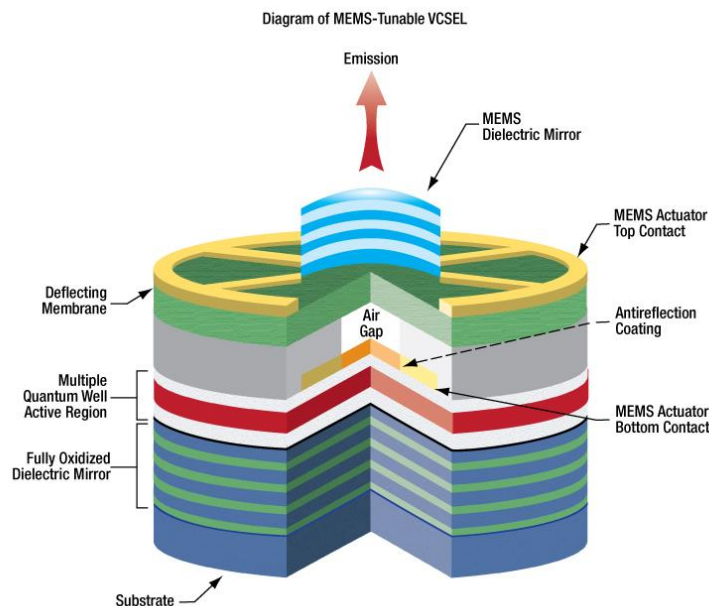

Figure 3.4.1.3.-4 – MEMS- Tunable VCSEL Diagram (permission requested)

Quantum well laser

A Quantum Well device bears much similarity to the heterostructure device that is composed of a layer of narrow bandgap materials such as gallium arsenide that is sandwiched between two layers wider bandgap material such as aluminum gallium arsenide. The quantum well laser however takes advantage of an ultra thin layer of gallium arsenide that essentially results in there being a one-dimensional well with x directional confinement. This confinement offers no constraint in the y or Z plane and because of this freedom the kinetic energy adds to the quantized energy levels forming a two-dimensional free electron gas [30].

The figure below (Figure 3.4.1.3-5) reveals an extremely simplified depiction of a Quantum Well. The well layer of GaAs is sketched as to show its thinness relative to the surrounding layers. Notice that the n-AlGaAs denotes doping with electrons as the impurities and the p-AlGaAs denotes doping with holes as the impurities. The roles that both doping configurations play under forward biasing which eventually bring about lasing will be discussed in further detail in the following paragraph [30].

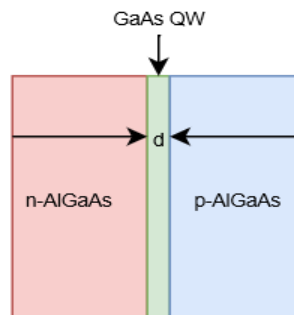

Figure 3.4.1.3-5 – Quantum Well Simplified Diagram (permission not needed)

For a single Quantum Well device (as in the case of our laser), the thin gallium arsenide well layer unlike the surrounding aluminum gallium arsenide layers Remains Not doped with impurities. This certain type of selective doping allows for the forward bias condition in which the n-type's electrons inject into the quantum Well's conduction band while the p-type's holes accumulate in the quantum Well's valence band. It is after this accumulation occurs that these conduction band electrons have little to no trouble filling states at the lower portion of the quantum well. The same holds true for the conduction band holes that will accumulate near the upper portion of the valence band well. The same does not hold true for the bulk semiconductor, which would have a thicker gallium arsenide Center layer that does not facilitate timely accumulation of charge carriers near the forbidden region. This rapid population in Quantum well laser means that under forward bias the current can be easily increased as permitted by the excessive electron accumulation. The stimulated transitions that proceed from following this accumulation allow for lasing [30].

We see then several advantages in using a Quantum Well laser device:

- A reduction in threshold current required for lasing compared with other semiconductor devices.
- A more narrow Optical gain curve due to the proximity of emitted Photon energy.
- An increase in the probability of radiative transitions.

There are however a few obstacles to overcome when using a single Quantum Well device:

- Radiative confinement is impeded due to the thinness of the quantum well.
- The well can be flooded with electrons when dealing with high current.

The benefits in using these devices can be fully realized by the reduction in lasing threshold current. This reduction means that less power will be wasted in bringing the device into its linear operating regime. Conserving power is usually a good thing when dealing with opto-electronic devices. This power reduction could also allow for the use of lower-powered drivers that tend to hold a smaller price tag. Also, because these devices have more narrow optical gain curves we can expect operation in relatively a single mode. This relative single-mode operation makes for an improved wavelength power as relatively easy detection segregation on the receiver side a free space transmission device [30].

The aforementioned downsides to this type of device are compensated for by with several useful methods. Firstly, the addition of optical confining layers around the Quantum Well can reduce the spreading of radiation into neighboring layers and thus compensate for the quantum well's lack of thickness. Another and possibly more effective option is to use multiple Quantum Wells containing alternating bandgap layers. These multiple Quantum Wells help to distribute the injected electrons and thus essentially eliminate the electron flooding seen with single Quantum Well devices [30].

Our laser Diode

The laser selected for this project is the OSRAM SPL LL85. This hybrid pulsed laser diode boasts of its low cost, and small size [39]. More notably, this device features an integrated FET and capacitors for pulse control, strained InAlGaAs/GaAs QW-structures, high-speed operation with a pulse with less than 30 nanoseconds, and a low supply voltage of less than 9 [39]. The following figures depict the pulsed laser diode and highlight the desirable output spectrum of the SPL LL85 laser diode.

Optical spectrum, relative intensity I_{rel} vs. wavelength λ ($P_{opt} = 14$ W, $t_p = 30$ ns)

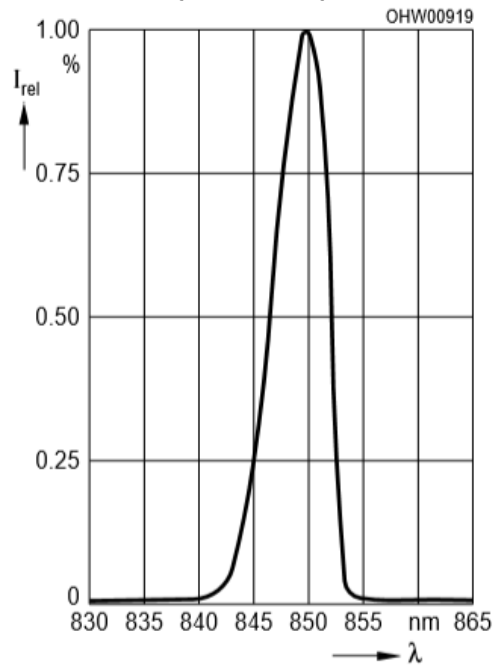

Figure 3.4.1.3-6 – Desired Output Spectrum for SPL LL85 Laser Diode (permission requested)

Another important specification to consider for this laser is the output power (in watts) versus the charge voltage V_c (in volts). Further examination of the below graph reveals that the threshold voltage is about 1.5 V.

Optical output power P_{opt} vs charge voltage V_c ($t_p = 30$ ns, PRF = 1 kHz, $V_e = 15$ V)

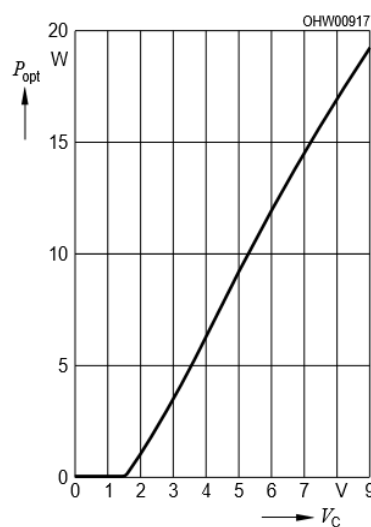

Figure 3.4.1.3-7 – Output Power vs Voltage for SPL LL85 Laser Diode (permission requested)

3.4.1.4. Laser Drivers

This laser relies on the Elantec EL7104C which is a MOSFET laser driver [39]. This is a non-inverting driver that features low supply current, improved performance over common CMOS devices, superior speed and drive capability, and overall high speed performance. This device is made non inverting (will not output an inverted form of the input signal) by including a 2nd inverting buffer. Enhanced speed and drive capability are made possible through matched rise/fall time delays. This driver also takes advantage of a “circuit that speeds up input stages by tapping wider voltage swing at the output [39]” in order to operate at high speeds.

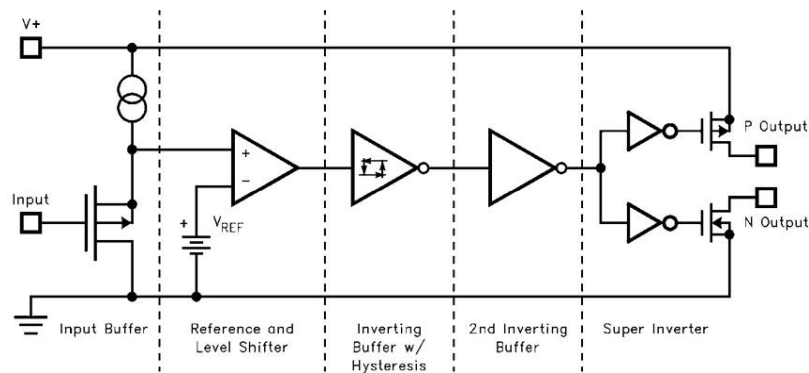

Figure 3.4.1.4 Elantec EL7104C MOSFET Laser Driver (permission requested)

3.4.2. Receiver

The receiver should meet the following requirements:

- Low power
- Operates fast enough to be able to obtain an accuracy of ± 6 inches
- Detects the wavelength of the laser being used
- Filters out all other wavelengths

The receiver is the part of the system that will detect the laser light that is reflected from an object. It will then take the information from the incoming signal and send it to the Time to Digital Converter (TDC) in order for it to be converted to a digital signal. This signal will be used to calculate the distance from the device to the object. There are three fundamental components that will make up the receiver. This includes a photodetector, filter, and lens. A plethora of options

are out on the market for each of these components, so an examination of them was in order. Here we elaborate on what those are and which we chose.

3.4.2.1. Photodetectors

Light sensors essentially take incoming light and convert it to an electrical signal. The electrical signal can be voltage or current depending on the type of photodetector and the mode it is used in. Several options for light sensors exist out on the market that could potentially be useful for measuring distance with light. Common types of light sensors include photoresistors, phototransistors, and photodiodes. Although all of these can be used to detect light, each of these types of light sensors have a different set of characteristics that should be taken into consideration when deciding which one to use for this project. The ideal photodetector would have low noise, high sensitivity to the desired wavelength, and high detection speed.

3.4.2.1.1. Photoresistor

The photoresistor also referred to as Light Dependent Resistor (LDR), photocell, or photo conductor, is a device whose resistivity is a function of electromagnetic energy – in this case, light. As light is shone onto the device, the resistance is reduced. Photoresistors are easy to manufacture and are low-cost. For this reason, they have been used for several applications including street lamps, camera light meters, and counting packages on a conveyor belt. They are made with semiconductor materials such as cadmium sulfide (CdS). These materials enable the LDRs to be sensitive to light. It is quite common for the values of resistance of a cadmium sulfide LDR to be on the order of mega ohms in the dark and fall to an order of a few hundred ohms in bright light [22].

Unlike photodiodes or phototransistors, photoresistors do not have a PN -junction making them less sensitive to light. Their photoresistivity also depends on temperature causing them to produce different resistance values even when the light intensity is kept constant. Another very important factor when it comes to precision and accuracy is the resistance recovery rate. It takes far too long for an average photoresistor to respond to changes in light. On average, it takes about 10 ms for resistance to drop in total darkness when illuminated, and up to one second for the resistance to rise again after complete removal of light. This makes them less than ideal for the precise task of measuring distance with a laser.

3.4.2.1.2. Phototransistors

Phototransistors are essentially light-sensitive transistors. The base and collector areas are much larger than a regular transistor even though most of time (unless the photocurrent needs to be masked) the base is not required and is left disconnected. Electron-hole pairs are generated in the base region when light enters the phototransistor, causing the injection of electrons into the emitter.

One of the major advantages of using a phototransistor over a photodiode is the amount of current gain due to the transistor action. This can range anywhere from orders of 50 to ten thousand depending on whether the phototransistor is a homo or hetero-structure [45]. For low-cost homo-structures the levels of gain range on the order of 50 to about 300. The disadvantage comes at the expense of high gain, as the higher the gain of the phototransistor the lower the response time. Response times for typical phototransistors are on the order of microseconds; far too slow for range finding using a laser.

3.4.2.1.3. Photodiode

Like phototransistors, photodiodes are semiconductor devices, but they operate due to internal photoelectric effect. As photons are absorbed in a photodiode, free electron-hole pairs are generated. The electric field transports the free holes and electrons resulting in a current being generated. Photodiodes can operate in photovoltaic mode (zero bias) or in photoconductive mode (reverse bias). Since the time constant in photovoltaic mode is high, the speed of a photodiode operating in this mode is low. A high speed photodiode is needed for measuring distance, and for this reason, the photodiode must operate in photoconductive mode.

When looking to use photodiodes for any application, one must take into considerations some crucial parameters to determine which one is would be sufficient for the project. In the application of measuring distance, four fundamental parameters must be looked at – dark current, responsivity, response time, and noise equivalent power (NEP).

Dark Current is leakage current caused by ambient light and by the photodiode itself in total darkness, giving it its name. This is essentially noise added to the signal. It is determined by factors such as the size of the active area and the material that the photodiode is made of. When operating in photoconductive mode, dark current is apparent adding more electronic noise. However, operating a photodiode in photovoltaic mode introduces minimal dark current at the cost of detection speed.

The current generated by the photodiode in photoconductive mode is very small. For this reason, the signal must be amplified. Unfortunately, with the amplification of the signal comes amplification of noise.

Responsivity is the ratio of the current generated by the photodiode and the input power from the light source and is represented by the following equation [31]:

$$R = \frac{I_{PD}}{P} = \frac{\eta e}{h\nu}$$

Where η is the quantum efficiency (ratio of charge carriers generated and the incident number of absorbed photons) of the photodiode given by the following equation [31]:

$$\eta = \frac{I_{PD}/q}{P_{in}/h\nu}$$

Where e is the electron charge and $h\nu$ is the photon energy incident upon the photodetector. In general, the greater the responsivity of the photodiode, the higher the performance it has.

The response time of a photodiode is how long it takes the device to respond when a change of light intensity occurs. It is determined mainly on the time it takes photocarriers to move across the depletion region of the photodiode, the time it takes for photocarriers that are generated to move outside of the depletion region, and the time constant of the photodiode in the circuit. Rise and fall times describe the response time of the photodiode when a step input, such as a square wave, illuminates the detector [31]:

Lastly, the NEP of a photodiode is extremely important. This is how much optical power would be needed to induce a photocurrent equal to the root mean-square of the total noise current. Since the NEP assumes that the signal-to-noise ratio (SNR) is 1, the photodiode must have a good quantum efficiency - high enough to generate a large signal power. The noise from the amplifier and the photodiode must also be kept to a minimum.

There are three main types of photodiodes:

1. PN Junction Photodiode
2. PIN Photodiode
3. Avalanche Photodiode

Silicon (Si) photodiodes are low in dark current, are high speed, and low in cost. It also varies less with temperature than other materials. For this reason, the material of the photodiode we will use will be Si. Since the gain of a photodiode is so small, amplification of the signal is required. This will be examined in the subsequent section.

PN Junction

A PN junction consists of a p-type semiconductor added to an n-type semiconductor. PN junction diodes are used for a variety of applications due to their ability to only allow current flow in one direction.

The joining of the two oppositely charged semiconductors creates a neutral depletion region consisting of negatively and positively charged ions. This

creates an electric field in the depletion region. If enough photon energy is incident on the photodiode, valence electrons break away from their parent atoms creating a hole in the process (electron-hole pairs). These electrons move freely creating electric photocurrent.

When a reverse bias is applied to the photodetector, the minority carriers in the depletion region move towards the sides where they are the majority, as shown in figure 3.4.2.1.3-1. Since the negative terminal of the voltage source is applied to the p-side and the positive terminal to the n-side, the holes move towards the negative terminal and the electrons to the positive. The total current of the photodiode is the sum of the dark current generated by the detector in the absence of light and the photocurrent.

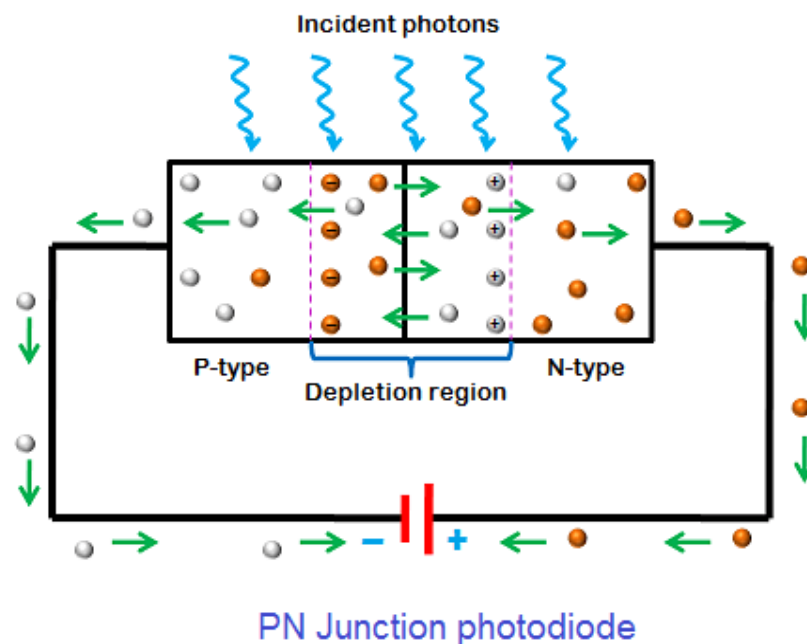

www.physics-and-radio-electronics.com

Figure 3.4.2.1.3-1 – PN Junction Photodiode (permission requested)

The primary candidates for the photodetector needed in our project are between the PIN junction photodiode and the avalanche photodiode (APD). This is due to the fact that we need the photodetector to be as fast as possible in order to detect the light pulses from the transmitter as effectively and efficiently as possible.

PIN Photodiode

A PIN photodiode (fig. [?]) has a similar structure to the PN junction photodiode. In order to reduce the capacitance of a PN junction, and thus improve the switching speed of the photodiode, a deep intrinsic semiconductor layer is sandwiched in between the positive and negatively doped semiconductors. The thick intrinsic region allows more space for photons to convert to electrons and

holes. Due to the high resistivity of the intrinsic layer, the PIN photodiode must be reverse biased as applying a forward biasing voltage would cause it to act like a resistor [35].

When the PIN photodiode is in reverse bias, the depletion region becomes wider due to the majority charge carriers from the p-region and the n-region moving away from the junction. The minority charge carriers in those regions experience a repulsive force from the external electric field generating an electric current. Photon energy incident to the photodetector is mostly absorbed by the layer of intrinsic semiconductor material due to the large depletion width created by the reverse bias voltage.

Because of the wide depletion region in the PIN photodiode caused by a reverse biasing voltage, the junction capacitance is low compared to a PN junction photodiode. The frequency response is also dependent on the junction capacitance is better the lower the capacitance is.

For PN and PIN photodiodes, the total shot noise, fluctuations about the dark current and fluctuations of the statistical randomness in the photogeneration process due to the quantum nature of photons [30] is calculated as follows:

$$i_n^2 = i_{n-dark}^2 + i_{n-quantum}^2 = [2e(i_d + i_{ph})B]^2$$

Where i_{n-dark}^2 is the mean square value of the shot noise current due to the fluctuations in dark current and $i_{n-quantum}^2$ is the mean square value of the shot noise due to the quantum nature of photons. B is the frequency bandwidth of the photodetector. Thermal noise is also introduced when components are added to the photodetector circuit such as resistors and amplifiers.

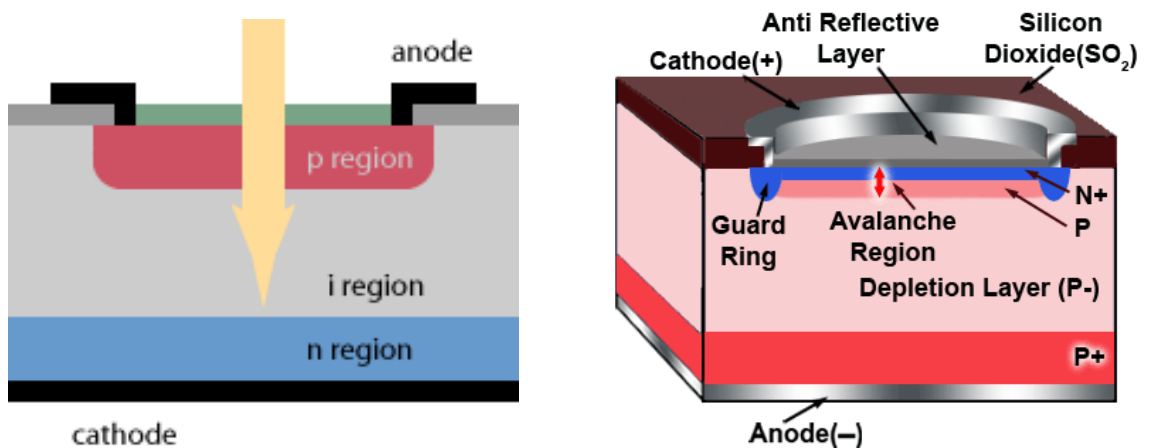

Figure 3.4.2.1.3-2 – a.) PIN Photodiode (permission requested) b.) Avalanche Photodiode (Permission Requested)

Avalanche Photodiode

The avalanche photodiode (APD) is a high speed PIN photodiode that generates internal gain and, like the PIN photodiode, is designed to operate with a high reverse bias voltage (fig. 3.4.2.1.3-2b). Using an APD is ideal because of its speed and sensitivity, allowing it to be able to detect lower power signals and shorter laser pulses. This is crucial in making any device eye safe at near infrared wavelengths such as 850 nm.

The mechanism for generating internal gain in an APD is impact ionization. When a large reverse bias voltage is applied and surpasses the photodiode's avalanche breakdown region, high electric fields are generated at the PN junction [30]. Electron-hole pairs in the depletion region gain kinetic energy and as they move through the region, they collide with other atoms. The impact from these collisions is done with enough energy to break the bonds and free the valence electrons in the atoms creating new electron-hole pairs. These new electron-hole pairs can also gain enough energy from the high fields to continue in the avalanche multiplication process. The formula [27] for the multiplication factor in an APD is:

$$M = \frac{I_{ph}}{I_{pho}}$$

Where I_{ph} is the multiplied photocurrent and I_{pho} is the photocurrent before multiplication. The formula [30] can also be approximated to;

$$M = \frac{1}{1 - \left(\frac{V_r}{V_{br}}\right)^m}$$

V_{br} represents the breakdown voltage with which the avalanche multiplication process begins. V_r is the reverse bias voltage applied, and m is a statistical index that provides the best fit for experimental data [30]. A downside to avalanche multiplication is avalanche noise.

As with all photodetectors, noise can be a major problem in an APD. The photogenerated and thermally generated carriers that are introduced in PN and PIN photodiodes are multiplied with the avalanche multiplication and so is the shot noise. The resulting equation [30] for shot current in an APD is:

$$i_{n-APD} = M[2e(i_{do} + i_{pho})B]^{\frac{1}{2}} = [2e(i_{do} + i_{pho})M^2B]^{\frac{1}{2}}$$

APDs also have an excess noise on top of the multiplied shot noise due to the randomness of impact ionization. This factor F is the excess noise factor that depends on the APD structure, that carrier that causes the avalanche, and the

material of the semiconductor. Taking this into consideration, the total noise [30] of an APD becomes:

$$i_{n-APD} = [2e(i_{do} + i_{pho})M^2FB]^{\frac{1}{2}}$$

Although the avalanche photodiode can have more noise than a photodiode that does not generate internal gain, it is the best choice since we need the receiver to be able to detect low powered signals for eye safety. Since we will most likely be using a Si APD, the noise should not be very large due to the fact that most of the impact ionization is due to electrons in silicon. However, we will have a PIN photodiode as a backup.

MOSFET

The metal-oxide-semiconductor field-effect transistor (MOSFET) is deserving of examination as well as it plays a vital role in the integration and overall operation of our device. On the note of the device's value, some would go as far as to say that the MOSFET "has become the most important device for the advanced integrated circuits such as microprocessors and semiconductor memories [60]". To fully grasp the importance of the MOSFET with its low power consumption, high yield, and optimum scalability a more in-depth study it necessary. The ideal MOS diode [60]

- At zero applied bias, the energy difference between the metal work function and the semiconductor work function is zero (the work function difference is zero).
- The energy band is flat (flat-band condition) when there is no applied bias.
- Only charges in the semiconductor and those with equal but opposite sign on the metal surface adjacent to the oxide exist in the diode under any biasing conditions.
- The resistivity of the oxide is relatively infinite so that under DC biasing there is no carrier transport through the oxide.

Certain cases exist at semiconductor surface when an Ideal MOS is biased with positive or negative voltages

Accumulation case:

For a p-type semiconductor, excess holes will accumulate at the SiO₂-Si interface when a negative voltage is applied to the metal field plate. Here, the near-surface bands bend upward with the exception of the Fermi level (E_f) which remains unbent due to the lack of current flow despite the applied voltage. Consider the following equation relating carrier density to the difference in the intrinsic and non-intrinsic Fermi levels (E_i-E_f).

$$Pp = nie^{\frac{(E_i - E_f)}{kT}}$$

Notice that the accumulation case is thus labeled because of the accumulation of excess charge carriers.

Depletion case:

Unlike in the accumulation case, a small positive voltage is applied that causes a downward bend of surface energy bands. This bending allows for the depletion of holes which are the majority carriers in the case of a p-type semiconductor. This case is thereby given the title of depletion case because of this majority carrier depletion.

Inversion case:

The application of an even greater positive voltage allows for further energy level downward bending. This excessive downward bending is so extreme that it allows for the introduction of excess electrons at the interface. This places an exponential dependence on the $E_f - E_i$ energies as follows:

$$Np = nie^{\frac{(E_f - E_i)}{kT}}$$

3.4.2.2. Operational Amplifiers

Ideal operational amplifiers, or op-amps for short, are integrated circuits consisting of several transistors, field effect transistors (FETs), and resistors that follow a certain set of rules whose primary function is to amplify the difference of two voltage inputs. Since there is no such thing as an ideal op-amp, the general function of it is to perform mathematical operations to a voltage such as multiplication, differentiation, and integration. Figure (3.4.2.2) shows a picture of an op amp along with a typical schematic representation.

Since the current generated by a photodiode is small, an op-amp is needed to amplify the signal. Factors that determine how effective an op-amp will be with a photodiode include linearity, offset, noise, and bandwidth.

For our application the most important factors are its ability to take in very low input currents, has low noise, and is high speed. Noise in an op amp is primarily due to Johnson noise from the resistor, the input current noise, and the input voltage noise. The bandwidth dictates the highest frequency that the op-amp can process. This means that the higher the bandwidth, the faster the op-amp. It can also dictate how accurate the op-amp detects a signal since the detection is based on the edge of the rise and fall time of the photodiode.

Using an op-amp as a current-to-voltage converter has the tradeoff of shifting the dominating noise source from the op-amp to the feedback resistor and back to the op-amp as the feedback resistance increases [12]. For this type of application, a transimpedance amplifier (TIA) may be the best option.

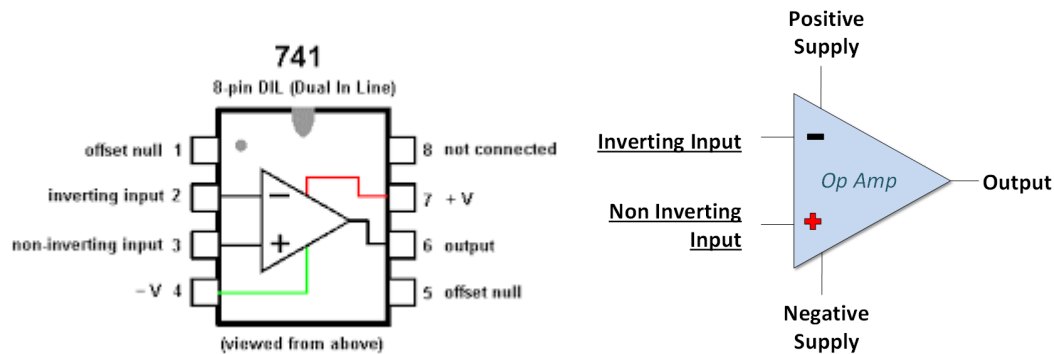

Figure 3.4.2.2 – Operational Amplifier Design (permission requested)

Transimpedance Op-Amp

The PIN photodiode outputs a very small signal current. This small current would need to be amplified by an operational amplifier and then converted to a voltage. The transimpedance amplifier's (TIA) main function is to convert current to voltage.

The TIA's gain comes from a feedback resistance connected to the amplifier's negative input (pin 2) and its output. The value of the resulting output voltage is obtained by using the equation:

$$V_{out} = -(I_{in} \times R_f)$$

In order to provide stability to the circuit, a feedback capacitor can be placed in the circuit in parallel to the feedback resistor. The following equation may be used to calculate the optimum value for the feedback capacitance [69]:

$$C_f = \sqrt{\frac{C_{In}}{2\sqrt{2}\pi f_{GBW} R_f}}$$

Where C_{In} is the sum of the junction capacitance of a photodiode and the common mode capacitance of the op-amp. The frequency in which the amplifier's gain becomes unity is denoted by f_{GBW} . This frequency is limited by the gain-bandwidth (GBW) product of the op-amp.

3.4.2.3. Optical Bandpass Filters

An optical filter is a device that transmits light of certain wavelengths through it while blocking other wavelengths of light. They can be extremely useful when measuring distance with a laser since lasers are monochromatic. Since there are many factors that go into what signal the receiver will detect, a narrow bandpass filter can assist in filtering out all the unwanted wavelengths of light and only allowing the specific wavelength of the light source to go through. The figure below shows the transmission graph for a near infrared (NIR) bandpass optical filter with a center wavelength of 850 nm. Typically bandpass filters have a bandwidth of about 50 to 100 nm while narrow bandpass filters have a bandwidth of about 5 to 10 nm.

3.4.2.3. Optical Bandpass Filter

An optical filter is a device that transmits light of certain wavelengths through it while blocking other wavelengths of light. They can be extremely useful when measuring distance with a laser since lasers are monochromatic. Since there are many factors that go into what signal the receiver will detect, a narrow bandpass filter can assist in filtering out all the unwanted wavelengths of light and only allowing the specific wavelength of the light source to go through. The figure below shows the transmission graph for a near infrared (NIR) bandpass optical filter with a center wavelength of 850 nm. Typically bandpass filters have a bandwidth of about 50 to 100 nm while narrow bandpass filters have a bandwidth of about 5 to 10 nm.

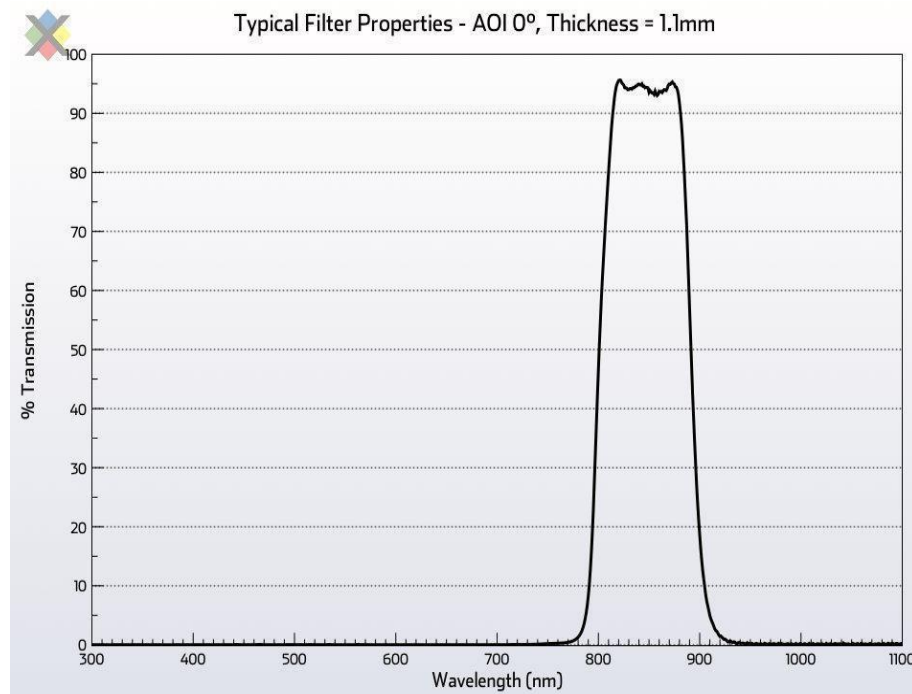

Figure 3.4.2.3 – NIR Bandpass Optical Filter Transmission Graph (permission requested)

Transimpedance Amplifier

The transimpedance amplifier's (TIA) main function is to convert current to voltage. For use with a photodiode, the signal would need to be amplified by an operational amplifier after the conversion occurs since the current is so small.

3.4.3. Power Management

Probably one of the most important ideas when dealing with keeping the cost of electronic devices low is the amount of power that the particular device is consuming. As electronic devices become smaller, there is a greater demand to place it onto a board, either within an integrated circuit or externally (however, keeping it on the same printed circuit board or single board computer). More devices are becoming integrated on an embedded chip due to both demand and Moore's Law. Moore's Law states that the number of transistors that can fit into a single chip will double usually every 18 to 24 months. As more transistors are able to fit onto the chip, a greater demand for power will be apparent. One of the bigger challenges for designers is creating devices that will optimally use power consumption. The idea is for each component to use the least amount of power possible. Since the device will be compact, power consumption must be taken into account for every external device. Luckily all MCU's are being considered for the design have low power modes that can be enabled via software.

For designers with the goal of optimizing power, one of the main ideas is to optimize power consumption by reducing the active processing time and maximizing the amount of time that the microcontroller can stay in sleep mode. With the increase of low-powered applications, it becomes increasingly difficult to the point where the aforementioned technique is no longer valid. There is more of a need to optimize power consumption across all levels of the system. Some techniques commonly used through efficient single-cell voltage conversion includes: utilizing multiple current nodes, introducing smart battery management, and implementing power-saving techniques at the application level. Doing so, the power consumption can be coordinated across the entire system.

Like the one currently being designed, many low-powered devices are moving to single cell batteries in order to minimize cost, size, and weight. Being able to minimize these factors allows for simplification of the battery holder and overall design. Typical single cell battery voltages range from 1.2 V to 1.5 V on full charge. However, due to the fact that the microcontroller will be responsible for the control of most functions, that voltage value could drop to around 1 V. Driving other peripherals such as the vibration motor and LED's can cause further dropping in the available voltage. Due to this fact, it is common for microcontrollers to have a voltage regulator to increase the available voltage to levels appropriate for proper operation.

3.4.3.1. Power Sources

As stated before, the power source will be responsible for powering all devices on the system. Although it would be simple to attach a 9V battery to power the system, other factors needed to be taken into consideration before making a final decision. It is well known that the real voltage of the battery and the supply efficiency is determined by the quality of the battery and the material that the battery is made out of. For these reasons, multiple types of batteries had to be taken into consideration. It is not as simple as one would expect when determining a proper battery for the intended application. There are many types of batteries available, so choosing the proper one will yield the maximum benefit.

3.4.3.1.1. Battery

To understand the importance of selecting a proper battery, it is important to establish a clear definition of one. A battery, in general, is a device containing one or more electrochemical cells that have external connections provided to power electronic devices. These products include smart phones, computers, flashlights, vehicles, and many other products. A battery has two terminals that can be distinguished by the positive terminal (called the cathode) and the negative terminal (called the anode).

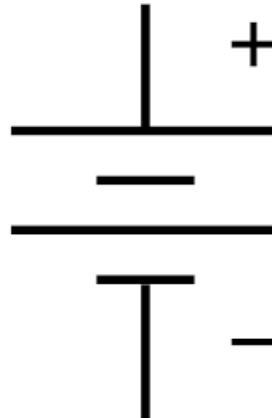

Figure 3.4.3.1.1 - Battery Schematic

The source of electrons is located within the negative terminal. When connected to an external circuit the electrons will deliver energy to an external circuit. During this process, electrolytes are able to move as ions within the circuit, allowing chemical reactions to be completed at the separate terminals of the battery to deliver the energy to the circuit. Previously throughout history, these batteries were a term referred only to devices that contained multiple cells. Throughout our history, technology has advanced enough to include devices composed of a single cell. Batteries also come in different shapes, sizes, and have differentiating

chemical properties. It is important to consider all of these factors when selecting a proper source for the application of interest.

3.4.3.1.1.1. Battery Types

For the application of interest; there are two main categories of batteries to choose from. The first, primary batteries, are designed for a one time use. They are typically exhausted of all their energy, and then discarded. The chemical reactions taken place within the battery are generally not reversible, making them unable to be recharged. Therefore, when the supply of reactants in the battery are exhausted, the battery will stop producing current and will render the battery useless thereon out. Manufacturers of these batteries strongly advise against attempting to recharge these batteries, as it is possible that they will not return to their original forms. These batteries are very commonly used in portable devices that have very low current drain, used well away from alternative power sources, or used intermittently. Common types of primary batteries are zinc-carbon batteries and alkaline batteries. These batteries have high energy densities compared to secondary batteries, and do not fare well under loads typically around 75Ω .

The first primary battery of interest is the zinc-carbon battery. The zinc-carbon battery supplies 1.5V between a zinc metal electrode and a carbon rod to form an electrochemical reaction. These were the first commercial dry batteries that made flashlights and other portable devices possible due to the fact that they can perform at any orientation without compromise to the battery. The physical properties of the battery include a carbon rod with a manganese (IV) oxide surrounding. A moist paste of ammonium chloride surrounds it, followed by a zinc case. Finally, a metal cap (+) and metal bottom (-) are applied to the ends. Carbon was used as the rod due to the fact that every common metal material quickly corrodes. These batteries have a relatively short shelf (not used) life. The zinc container becomes thin due to the zinc being attacked by ammonium chloride. It is during this process that the zinc chloride begins to leak out of the battery.



Figure 3.4.3.1.1.1-1 – Zinc-Carbon Battery (permission not needed)

Alkaline differ from zinc-carbon ones in that they have a much higher energy density and longer shelf-life, supplying relatively the same amount of voltage. This battery is unique in that it has a capacity of three to five times that of a zinc-carbon battery of equal size due to the manganese(IV) oxide being purer and denser. Also the space taken up by internal components is much less. The construction of alkaline batteries is dependent on the desired current. A cross-section similar to that of the zinc-carbon is shown for comparative reasons.

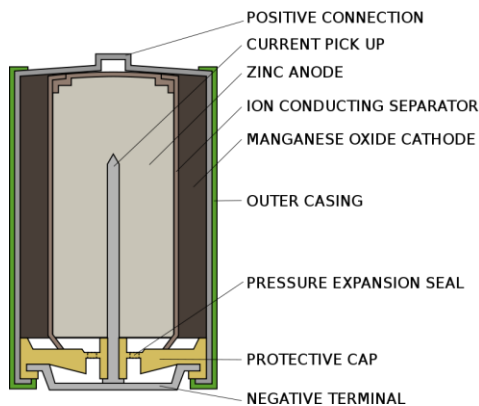

Figure 3.4.3.1.1.1-2 – Alkaline Battery (permission not needed)

Most notice that there are multiple sizes of the alkaline batteries. These different sizes are correlated with their capacities, which are strongly dependent on the load. For example, a AA alkaline battery will have, on average, an effective capacity of 3000 mAh or as low as 700mAh. This effective capacity is entirely up to the load. So, for applications that deal with mostly light current drainage, an AA sized battery would be sufficient. Though if the load requires a large current (for example stereos, flashlights, etc), the sizes that would satisfy the current

demand would be closer to C or D. Once in use, the voltage of the battery will steadily decline.

One main issue regarding the use of alkaline batteries is leakage. Studies show that alkaline batteries which, like most batteries, are prone leakage. The potassium hydroxide that gets leaked from these batteries are known to cause respiratory, skink, and eye irritation. These leaks are usually caused by some sort of discharge. Whether powering a device or not, batteries will discharge. During the discharge process, hydrogen gas is generated. As the gas steadily grows within the battery, pressure builds up unto the point of rupturing the insulating seals on the battery. One could see that this would be a potential problem for the intended use of batteries in this project. One solution that would potentially prevent leakage would be to replace the batteries once the unit has stopped working. Another solution would be to not mix different types of batteries. Also, since these batteries are not rechargeable (with the exception of a select few); any attempts to charge them will increase the likelihood of the battery rupturing.

The second, secondary batteries are different from primary batteries in the fact that they can be recharged. The chemical reactions within these batteries are reversed by applying an electric current into the cell. Doing so generates the chemical reactants originally found within the cell, rendering them useful for multiple charges. The amount of times that they are able to be charged is limited, however. The amount of times they will be able to be recharged is dependent on multiple factors such as the chemical properties of the battery and the amount of current being supplied to the battery. The two types of secondary (rechargeable) batteries being considered for the design are nickel-metal hydride (NiMH) and the more popular lithium ion (Li-ion) battery.

The NiMH battery has a voltage charging range of around 1.4-1.6V per cell and has a unique method for charging. In most types of these batteries, the constant-voltage charging method cannot be used for charging these batteries. Also, for fast charging, there is usually a smart charging device that's used to prevent overcharging. Overcharging the battery will cause damage to the cells. Another issue with these types of batteries is over-discharging. In the event of complete over-discharging, the cells of the battery can experience complete reverse polarity. Doing so will cause permanent damage to the cells. There are three common methods that are used to charge the battery: the trickle charging method, the ΔV charging method, and the ΔT charging method. The trickle charging method is seen as one of the safest charging methods in that it is one of the simplest methods. The trickle method is accomplished by applying a fixed low current. This is done either with or without a timer. For the ΔV charging method, the change of voltage with respect to time is used. In order to prevent overcharging and cell damage, the fast charging cycle needs to terminate the charge cycle before overcharging occurs. The mentioned method of charging helps by detecting a slight drop in the voltage once the battery is fully charged. At

this point, the charger detects this and stops charging. One issue with this method of charging is the risk of a premature cutoff.

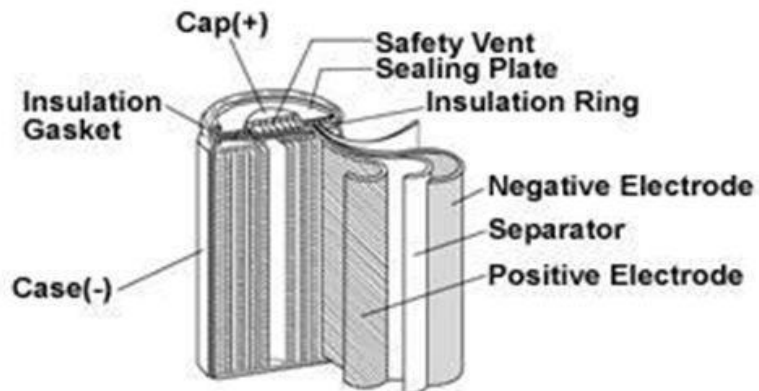

3.4.3.1.1.1-3 – NiMH Battery (permission not needed)

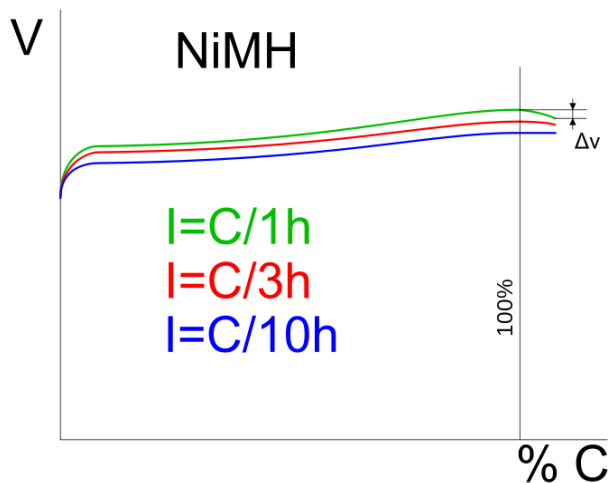

3.4.3.1.1.1-4 – NiMH Battery Charge Curve (permission not needed)

As one can see from the figure, the faster the charge, the harder it is to precisely obtain a cutoff at 100% charge. One will notice that the faster the charge on the battery, the more likely one will run into the risk of overcharging. Throughout the years, this was dealt with by designing the battery to terminate charging when the voltage drops to around 5-10mV from the peak voltage. The final method of charging, the ΔT , uses a method similar to the ΔV method. Due to its similarity, a constant current is being delivered similar to that of the ΔV method. Although most of the reactions existing within the battery, when the battery reaches close to full charge, heat is released. This is where the ΔT method is unique. During the last part of the charging, a temperature sensor detects and monitors the temperature of the heat being released. Once the ideal temperature (determined by factors such as the time and desired voltage) has been reached, the charging

will stop. This is advantageous in that it will allow for an absolute temperature cutoff, which in turn, will allow for a more precise voltage cutoff.

The next type of secondary-type battery being considered is a more popular choice amongst builders, the lithium-ion battery. In this battery, the lithium ions move from the negative electrode to the positive one when discharging, and then back to the negative one while charging.

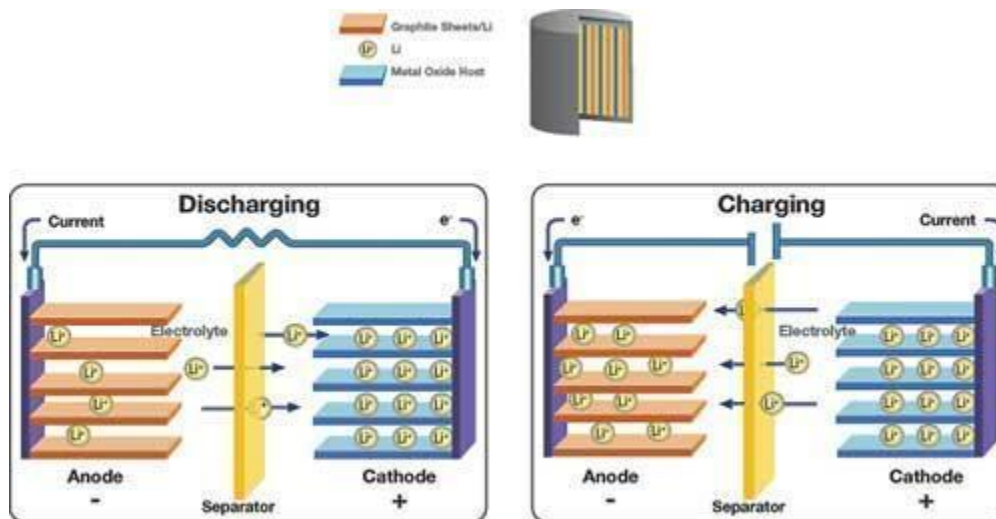

3.4.3.1.1.1-5 – Lithium Ion Battery (permission requested)

These batteries are most popular amongst home electronics and portable electronics, due to the fact that they have a high energy density, low self-discharge and minimal effect to memory. They are also becoming increasingly popular in military, aerospace, and electric vehicle applications. Though they are becoming more of a standard amongst batteries, they do not come without certain risks. They can be dangerous under certain conditions and can pose a safety hazard due to the fact that they contain a flammable electrolyte that is kept pressurized. Due to this hazard, there are more stringent safety factors put in place to ensure minimal hazards.

The two parameters of interest are the charging and discharging. During the discharging process, the lithium ions deliver current from the negative electrode to the positive one. During the charging process, a voltage from an external source (the charger/charging circuit) is applied to the terminals. The voltage of the external source is higher than that of the battery. This setup forces the current flow within the battery to reverse, sending the lithium ions back to the negative electrode from the positive one. The charging processes of the single cells and the battery as a whole are slightly different. The charging process in the single cell goes through two phases, whereas the whole battery goes through three. The processes within the phases are similar between the single cell and the whole battery. The first phase, performed by both the single cell and the battery is the constant current phase. During this phase, a constant current is

being applied to a steadily increasing voltage. The current stops once the voltage limit either within the cell, or the entire battery, is reached. The balance phase is the second step that only the whole battery experiences. During this phase, the charging current is being reduced while the state of charge within the individual cells is leveled out until the entire battery is charged. The method of balancing the current in the individual cells varies. The final phase is the constant voltage phase. During this phase, a voltage equal to the maximum voltage times the number of cells is applied to the battery as the current approaches zero.

Battery Type	Avg Voltage Range (per cell)	Avg Self Discharge Rate (room temperature)	Avg Cost (1-AA)
NiMH	1.4-1.6	0.5-4%	\$3.00
Li-Ion	3-4.2	15%	\$4.00

Table 3.4.3.1.1 – Battery Comparison

Both battery types can be used for the intended application; however, proper selection will be determined by price and drain rate.

3.4.4. Timing

We researched other existing laser rangefinders available. One was the OSLRF-01 laser rangefinder from lightware optoelectronics. The OSLRF-01 is an open source range sensor that uses time-of-flight to detect targets. For this rangefinder system to work it uses sequential-equivalent-time-sampling circuits which is simply referred to as (SETS).

The SETS circuit slows down a signal obtained by a laser using a high frequency oscilloscope. This makes it possible to view the signal and for it to be captured by the ADC inputs of a microcontroller. The signal is slowed down by 100,000 times of the real time value. The signal is then operates on an expanded time base, which can be altered for different update rates and resolution of measurements.

For this timer in particular the real-time span is 122ns, which will calculate a distance up to 18.33m at the speed of light. Using the SETS circuit this time span can be stretched to 20ms and even possibly up to one second. No matter what duration it always equates to a distance of 18.33m.

To obtain a distance, a Sync signal is used to determine the start and end of measurements in the expanded time base. 18.33m is always the period of this Sync signal. So any distance the rangefinder will obtain will just be a proportion

of the Sync period. To make the expanded time base faster or slower the Control voltage input is adjusted and then the period of the Sync signal will be changed as well.

The analog signals that send the signal and receive it are both timed with the Sync signal. Essentially to obtain distance you need to take the time of the leading edge of a signal, divide it by the period of the sync, and then multiply it by 18.33m. However, in the expanded time base you need to take into account the delay the laser actually takes to fire. For the OSLRF-01 the delay is ten nanoseconds. To get an accurate measurement for distance the equation ends up being $d = ((R_t - Z_t) / Sp) * 18.33m$. The time of the return signal from falling edge of Sync reference is R_t , and the Zero signal from the falling edge of Sync reference is Z_t .

Software algorithms analyze the signal from the Zero and return signal. This is simply done by defining a virtual threshold voltage in software. It will count the number of ADC samples from the falling and rising edges of the threshold. The amount of “ticks” it takes from the rising edge of the return and zero and the falling edge of the Sync gives the distance as:

$$\text{distance}_{\text{to target}} = \frac{(\text{ticks_to_return} - \text{ticks_to_zero})}{\text{ticks_between_Sync_edges}} * 18.33m$$

Another rangefinder we researched was the DS00 Laser range finder from lightware also. The DS00 also uses the time-of-flight method to obtain range. It uses a pulsed laser and is designed for long distance measurements.

Focusing on the timing module we looked at how they measured the time it takes for the laser to travel from the laser module to a target and then back to the receiver. The DS00 uses a timer chip called the DS00VQ100. This chip controls the triggering of the laser, measures the outgoing zero and return signal, and also controls the bias power supply for the Avalanche Photodiode. This rangefinder has the potential to measure up to 1cm range, but to accomplish this it needs to be able to resolve signals at a precision of 67ps.

Just as the OSLRF-01 laser rangefinder used high precision oscillators, the DS00 uses the same method to read the signals obtained. The signal can be slowed down to a rate readable for Analog-to-Digital conversion. The process is called down conversion and can be comparable to a radio frequency mixer. Once the signal is slowed down, a 25kHz timer is used to measure the signal. The results for the real time and expanded time are read on an oscilloscope.

The DS00VQ100 is connected via SPI bus to the processor module. At the processing module the user can read timing results. The user can also calibrate and configure data with an EEPROM.

To read and process a laser signal with the existing rangefinders we researched, we found out that it was achieved with down conversion. Both of the rangefinders we researched from lightware used high precision oscillators for down converting the signal. By definition, a digital down converter converts a digitized, band limited signal to a lower frequency signal at a lower sampling rate. Ultimately our laser signal must be shifted to a lower frequency for our processor to read it. At the same time removing unwanted signal components.

For digital down converter to work, we study one simplified example in detail. For this DDC, it first takes the digitized signal taken from the analog to digital converter. It then mixes the stream of samples with a digitized cosine and sine wave for the phase and quadrature channels, respectively. This generates the sum and difference frequency components. The phase relationship remains the same, keeping the filters the same in the phase and quadrature channels. The spectrums of the signals are filtered using identical digital filters. Any unwanted frequency will be left out because they are outside of the filter. Now the frequency, without loss of information, can be reduced to a manageable frequency.

The negative frequency signals can be cancelled out if the phase and quadrature signals combine as a complex value. There will only be the positive signal left with a spectrum set up in this way.

Not only does digital down conversion simplify how the data is processed, it allows more information to be processed at the same time, and can help reduce the power consumption.

When using digital down conversion, deciding which Analog-Digital-Converter comes into question. Nyquist's theory states that the sample rate should be double the bandwidth. Sometimes this can be impossible with today's technology and frequency shifting might be required beforehand. This is done with an IF stage in analog. Most systems use a combination approach. An IF stage can make the signal more manageable so it can be processed digitally. There are advantages and disadvantages for having digital down convertor over using analog techniques. One advantage is the digital stability. You can be sure it will work in any temperature or other condition. If it is set up right to work, it will work. Another advantage is the controllability. Since frequency change can happen so rapidly and in large intervals the digital down converter can handle this being that all aspects are controlled with software. Lastly, an advantage with dealing with a big system is that digital down converters can handle multiple Analog-to-Digital converters. There can be multiple channels working with one down converter.

Some disadvantages are the analog-to-digital converter speeds are limited to do it in all digital process. Sometimes it's easier to start by using an analog circuit to bring it down to a intermediate frequency. Also, another disadvantage is that the analog-to-digital converter has a limited dynamic range.

3.4.4.1. Time-to-Digital Converter

There are different ways to achieve time to digital conversion. The basic choices of route is an analog time-to-digital converter in which you take the time interval, create a voltage from it, and create a digital value out of the voltage. The other choice is to use a counter base time interval, which would be referred to as a digital TDC.

Most people link time-to-digital converters with phase-locked loops. This was the most famous way to convert a time interval, which works by detecting the phase. Other methods have been discovered and people have branched off from this method. The application dictates the best process, because each has pros and cons.

The reason for using digital in the first place is the size advantage. You can fit much more complex and flexible processing systems with digital, as well as it being more efficient and productive. All of this with the added benefit of cutting out noise and coupling disturbances makes digital and TDC technology desirable. This is all opposed to the disadvantages, which come with analog like power consumption or temperature change. The generic go to model for TDCs is seen in the figure below.

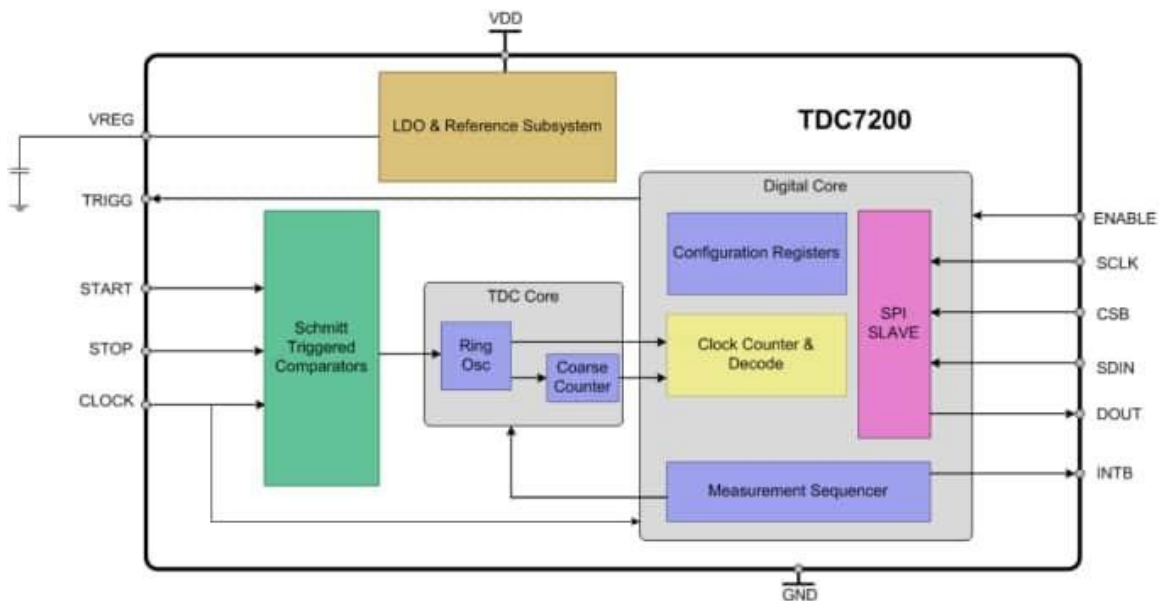

Figure 3.4.4.1-1 – TDC7200 Schematic (permission requested)

To improve on this model, digital techniques can enhance mixed-signal building blocks. For example, the content could be reduced and calibration methods can increase performance greatly. The scaling of the system to a sub-micron level will help by increasing overall speed, in addition to the obvious area reduction. As technology has developed that has been less and less classical mixed-signal circuitry. TDC technology has further and further gone in the direction of digital

enhancement techniques. These future models are looking more and more like the figure below.

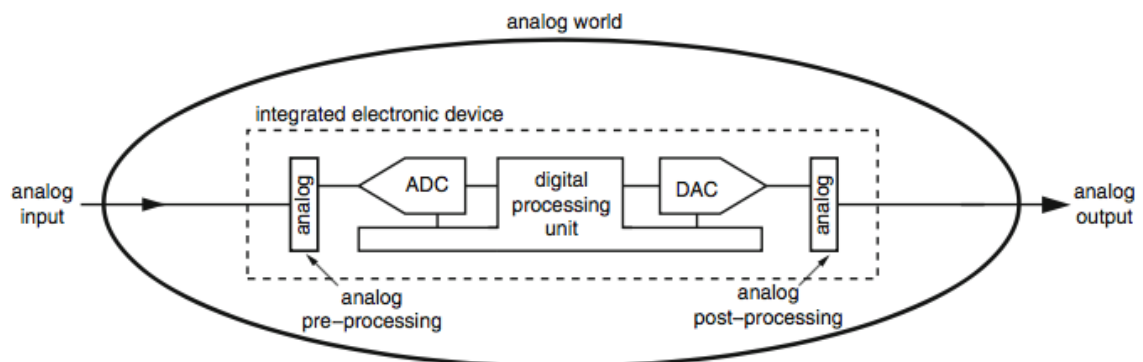

Figure 3.4.4.1-2 – Time-to-Digital Conversion (permission requested)

The analog time-to-digital converters work by transforming a time interval into a voltage. Then an analog-to-digital (ADC) digitizes this voltage. There is a starting and ending point in which a pulse is formed with a width, which parallels to the time interval. The pulse is converted to a voltage fed to the ADC. The downside of this method is the need for linearity. All steps involved need to meet full linearity demands of overall TDC.

More advantages of time domain can be capitalized on if the analog portion of this process is cut out. An easy way to do this is to sum cycles of a reference clock fitting into a respective measurement interval. Ways to improve the system are to make a higher clock frequency for measurement accuracy. On the flip side the higher the frequency will consume more power.

TDCs can use crystal oscillators for a referencing frequency. The only downside is the comparative low frequency coming from the crystal at about 10 MHz giving a 100 ns resolution. If using 65 nm technology the maximum frequency is limited to 5-10 GHz, giving a maximum accuracy of 200-400 ps. Higher resolutions can be achieved by subdividing clock speeds into smaller time intervals asynchronously by the digital TDC.

This subdivision of the clock is also known as reference clock interpolation. The phases can be derived from the oscillator or reference clock, or the original reference clock can be delayed in a chain of digital delay elements. This method gives far better accuracy, but the downside is a much smaller measuring range. The operating principles of digital delay-line are shown in the figure below.

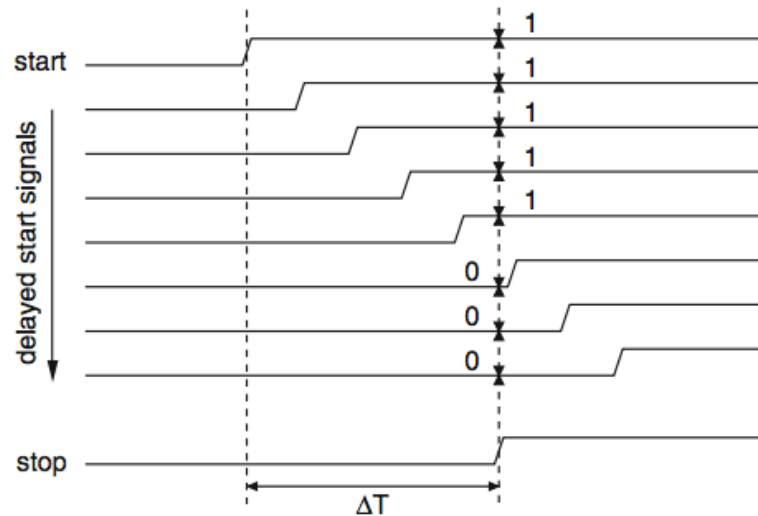

Figure 3.4.4.1-3 – Digital Delay Line Operating Principles (permission requested)

Flip-flops are used for the outputs of the delay elements and sample at the start of the rising edge of the stop signal. The problem with this design it is delayed by the delay of the buffers. If these buffers were to be replaced by CMOS inverters, the resolution could be doubled. This just mean not only the rising edge of the signal will be read, but also the falling edge.

The pros of both of these all digital TDC's are that they are simple, low power, low latency, and easy to control and embed. The latter example just adds double the resolution. The negatives of the inverter TDC deals with the alignment of delay-lines and a double number of comparators for the same dynamic range.

Our choice TDC

For the time-to-digital conversion we have acquired the TDC7201 from Texas Instruments. This TDC is specifically for ultrasonic, laser, and range finding equipment using time-of-flight techniques. Our rangefinder will be required to measure distances as small as 6 inches and up to a few meters. This is well in the range of the TDC7201. It can measure distances down to 4 cm and up to several kilometers.

This TDC is designed with simple architecture, and this helps to remove the need for expensive FPGAs or processors. From the time our laser begins with a start pulse, this TDC will act as timer until the laser finishes with up to five stop pulses. This is available because it has two built-in TDCs equipped to measure these pulses simultaneously.

Our laser rangefinder is going to need a fast TDC, because we will be dealing with measuring times to the picoseconds. This TDC is made for handling these situations. It is self-calibrated which allows for it to produce conversion accuracy

in the order of picoseconds. That is why this TDC will be perfect for our rangefinder.

In order to save battery life, which is a huge concern for our rangefinder, the TDC7201 has an option called Autonomous Multi-Cycle Averaging Mode. This gives the option for low system power consumption. It can sleep until interrupted saving us power.

Some of the features for the TDC are a resolution of 55 ps. The measurement range can handle .25 ns to 8 ms with combining both TDCs. This works out within the range of our laser. To power the TDC it requires between 2 V to 3.6 V. In low power consumption can be down to 2.7 mA.

The price of the TDC7200 is \$5.06 on the Texas Instruments website. The price difference does affect the decision, as both TDCs are very cheap. The good thing about being a student and ordering from TI is that we were able to get these small parts for free.

The TDC7201 works perfectly in our system with how it can work with the speed of the laser. The downside, as it was before, is the amount of voltage it needs. This might make our final product to big and uncomfortable to the user.

Our other option for a time-to-digital convertor is the TDC7200, also created by Texas Instruments. Although this TDC is almost identical to the TDC7201 there are some differences. Some differences in the TDC7200 features from the TDC7201 are Low Active Power Consumption of 0.5 μ A, it only supports up to 5 STOP Signals as opposed to 10 STOP Signals, and the difference in measurement ranges for Mode 1: 12 ns to 500 ns, while Mode 2 is the same. The Mode 1 for the TDC7201 can handle 12 ns to 2000 ns. With the need for our accuracy either measurement range should work. Although the application examples on the data sheet do not list Lidar Rangefinder as with the TDC7201, it does list Time-of-Flight in Drones (Lidar). The other aspects as far as the accuracy and low power mode should give us the same results as the TDC7201.

Considering all the research on the two TDCs we have decided to go with the TDC7200 over the TDC7201 because the device package is easier for us to test and use. The TDC7200 has a TSSOP (14) package, while the TDC7201 has an nFBGA (25) package. The TDC7200 works out better when testing because of the difference in pin placement.

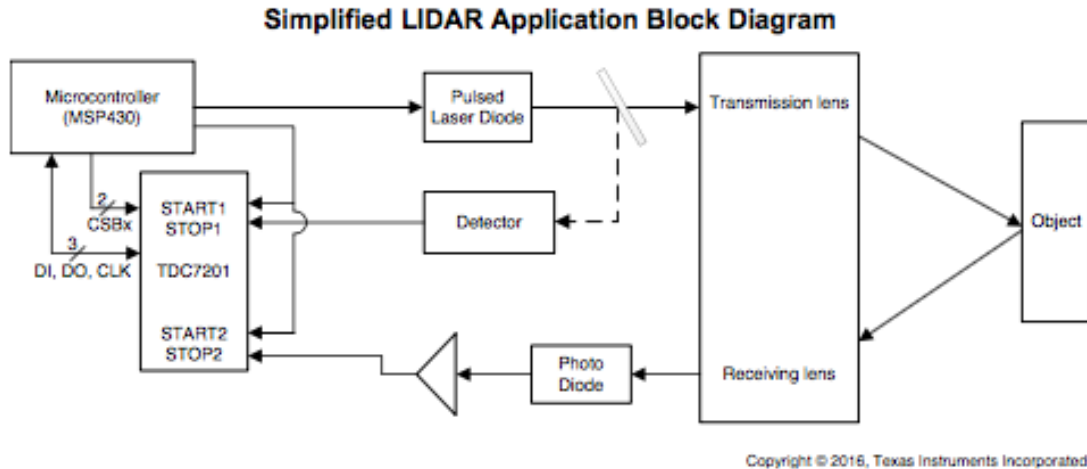

Figure 3.4.4.1-4 – LIDAR Application Simplified Block Diagram (permission requested)

3.4.4.2. Direct Down Conversion Receiver

To handle the direct down conversion we can use a wide bandwidth integrated direct down conversion receiver. The TRF371135 from Texas Instruments supports a 700 – 4000 MHz frequency range. It is a linear direct-conversion quadrature demodulator. The supply voltage will require 4.5-V to 5.5-V for operation. It has integrated into it a programmable-gain amplifier as well as an on-chip programmable baseband filter. The programmable-gain amplifier will allow us to adjust the output signal level without any need for another variable-gain device. The programmable baseband filter will help eliminate nearby interference, erasing any need for us to make an external baseband filter.

Demodulator

Space for the demodulator shouldn't be a problem for our rangefinder. It is housed in a 7mm x 7mm QFN package. TI claims this is the smallest available demodulator solution for high performance equipment. The only problems we see with the TRF371135 is the amount of power it will require. The more power we need to use might result in a bulky range finder, which we are trying to avoid.

Ti demodulation option

Texas Instruments gives us another option for a demodulator with almost the exact same specifications. It is the TRF371135. The only main difference is it would give us a broader frequency range of 1700 MHz to 6000 MHz. The power consumption and size of the demodulator remains the same.

The price of the TRF371135 from TI is \$26.57 from the website. This would add a lot of cost to the overall product if we paid this price since we haven't officially obtained a sponsor. With the student UCF email account we were able to get a

free sample of the demodulator. This helps with the overall cost of the project immensely. Even though if we had to pay the full price, if the rangefinder was sold and distributed on the market, this price would not be as significant once mass produced.

Choice down converter

The TRF371135 provides a good down converter for our laser rangefinder. The only problems that we might face using it are the power consumption. We are trying to build our range finder small enough to be comfortable on someone's wrist or holding it in his or her hand. The more power we need the bulkier our final product will become.

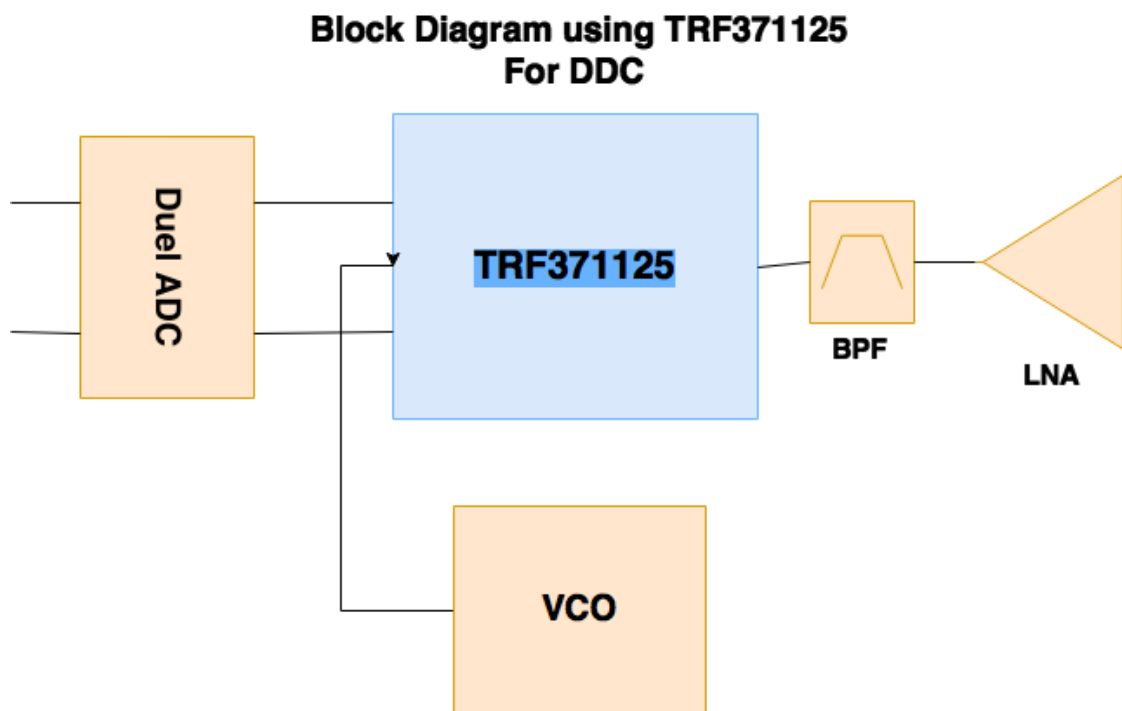

Figure 3.4.4.2 – TRF371125 Block Diagram (permission requested)

3.4.5. Lenses

There are several different types of lenses on the market for a wide variety of uses. Some of these include achromatic, acylinder, and plano-convex among others. In the following section we will describe different lens types that may be suitable for our project.

3.4.5.1. Types of lenses

Achromatic Cylinder

The Achromatic Cylinder lens is helpful when desiring less spherical and chromatic aberration. Also, this lens type can significantly reduce the beam spot size when illuminated with a relatively monochromatic light source. This cylindrical lens (shown below) offers a benefit over a single lens because it makes use of both a positive low-index segment and a negative low-index segment. These lenses excel in focusing incident light in one dimension [20].

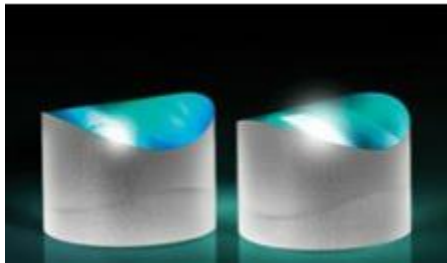

Figure 3.4.5.1-1 – Achromatic Cylinder (permission requested)

Acyylinder Lenses

Acyylinder lenses (such as those below) like Achromatic Cylinder lenses can reduce monochromatic source spot size, focusing light in one dimension. The focusing provided by these lenses is said to be diffraction-limited [20].



Figure 3.4.5.1-2 – Acylinder Lens (permission requested)

Fast Axis Collimators

Fast Axis Collimator lenses (pictured below) offer reduced size, high quality laser beam collimation, and uniformity in the form of aspheric cylindrical lenses.

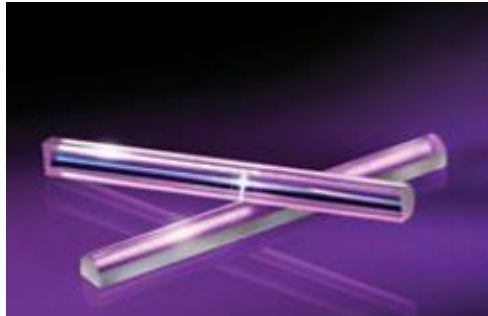

Figure 3.4.5.1-3 – Axis Collimator Lens (permission requested)

High Performance Cylinder

The emphasis of this lens is in one dimension. The ability to magnify in one dimension, focus in one dimension, and leave the other dimension practically unimpeded makes these cylindrical lenses very useful in applications such as in a line scan detector [20].



Figure 3.4.5.1-4 – High Performance Cylinder (permission requested)

3.4.5.2. Collimating laser light

Collimating laser light is essentially no different than collimating a broadband source (like a white light source). The significance of this collimation for our design cannot be emphasized enough. Sending uncollimated light to a distant target would result in an excessively divergent beam of light. This divergent beam could make detection after back reflection nearly impossible, as most of the original signal gets lost in a sea of noise. Figure 3.4.5.2 (below) depicts how the light leaving the laser chip (although not a continuous wave) quickly diverges. This divergence although undesirable can be compensated for with the use of a positive (collimating) lens. Specifically, if the source of this light is placed on-axis at a point exactly one focal length away from the lens then the resulting light should come out collimated. It is important to keep the lens at a focal

length distance away because the laser transmission will not remain collimated should the lens move closer towards or further away from the source. We see then the vital role that a collimating lens plays in the successful operation of our laser ranging system.

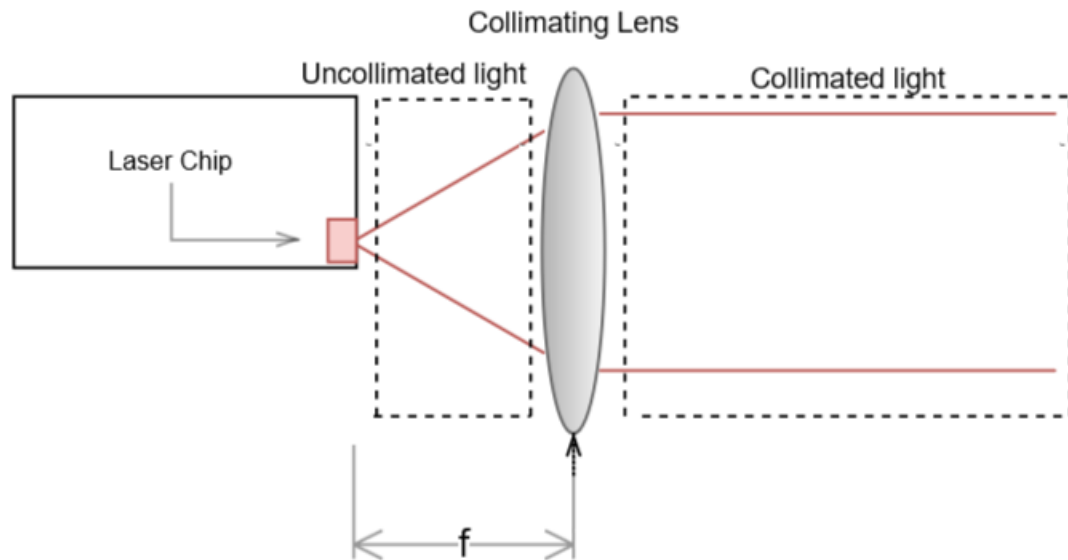

Figure 3.4.5.2 – Collimating Lens Laser Diagram (no permission required)

3.4.5.3. Lens modeling

Beam spot size

The previous mentioned methods of collimated light using a positive lens simply offer an elementary overview of the light propagation. A more detailed investigation is required to shed light on more desired lens design specifications. These requirements play a vital role in furthering optical analysis, design, and implementation of our system. Specifically, given the size of the detector's active area and the range specifications of our laser ranging system we can begin to analyze the transmitted laser beam. This analysis should allow us to determine the beam waste of the collimated light following transmission through the lens. It is of no surprise that the optimum distance the lens must be from the source in order to have the best beam waist is simply one focal length away. Alternatively, we can adjust to being waste by introducing a beam expander after the source and prior to the lens. Integrating this beam expander into our system could potentially offer further optimization and more desired operation. Below (Figure 3.4.5.3) is a potential design of a beam expander that we can use to improve system performance. This beam expander can be used to it either increase or decrease the beam waist dependent upon the orientation of the lenses.

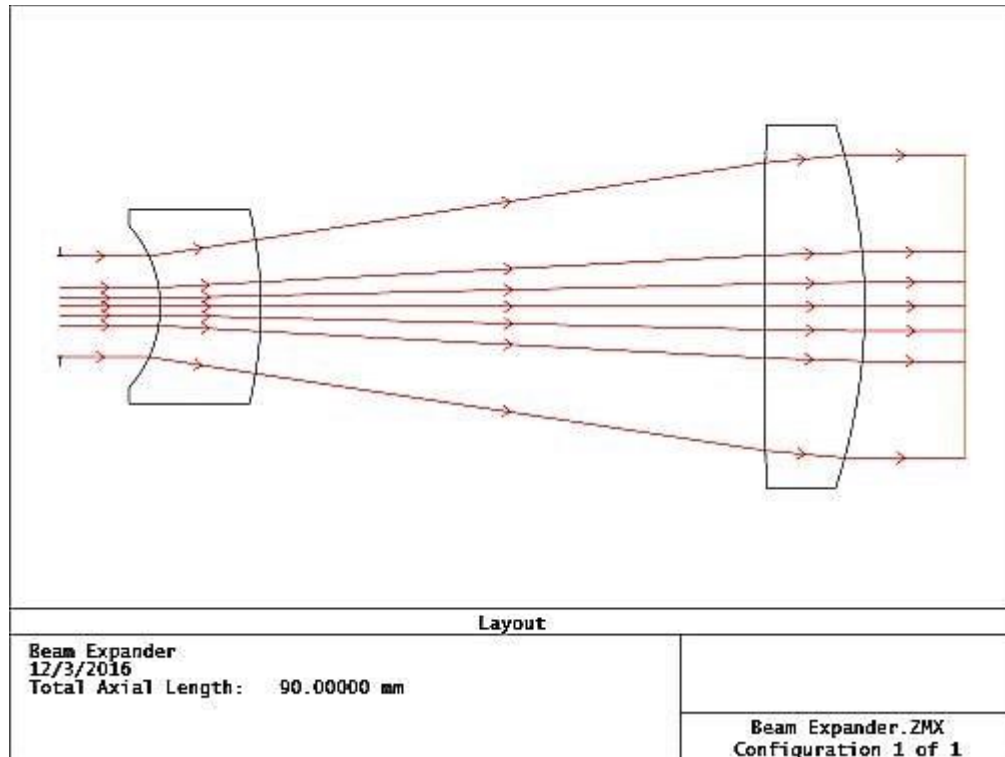

Figure 3.4.5.3 – Beam Expander (permission not needed)

Moving forward from the beam waist specifications, we can then consider optics on the receiving end. It is there that early being specifications are most important.

3.4.6. Haptic Feedback

Our rangefinder needs to have some sort of feedback to the user to alert him/her of their surroundings. For this, we will be using haptic feedback, or also simply referred to as ‘haptics’. People are most familiar with haptic feedback with its implementation in cell phones. When your phone vibrates because of an alert or when you touch something on your screen it is the haptic feedback of the phone. Haptic feedback is simply the forces and vibrations a user feels from a source through sense of touch. For our project the haptics will be vibrations the user will feel alerting of objects within a certain range. The feedback will alternate to demonstrate different variations of range allowing the user to move confidently in his/her surroundings.

3.4.6.1. Vibration Motor

The motor we are using is a small coin mobile phone vibration motor. At 3 V it will produce 0.1A and at 1.5 V it will produce 0.05A of current. Depending on the housing of our rangefinder we can use one motor or have the possibility of using two. They are fairly small at 0.2 ounces. The dimensions are 10 mm x 2.7 mm. For their small size, the vibration is strong enough to alert the user when an

object is in range. The type of vibration motor is an eccentric rotating mass vibration motors, or ERM. Through Amazon we were able to find 5 of the motors for \$7.00. Not only are they a good option because of power and size, they are also inexpensive, which helps with the overall budget.

There is another option we could choose from when choosing a vibration motor. Besides the ERM, which we have chosen, there is linear resonant actuator, or LRA's. The LRA contains a small internal mass that is attached to a spring. When driven, it will create the necessary force. The ERM uses a DC motor with a small unbalanced mass attached to it. When this is driven it produces the force, which renders vibrations.

These vibration motors have been used for decades in mobile devices and massage products prior to that. The size and power both translate perfectly for the rangefinder we are making.

The ERM we have chosen is the coin or 'pancake'. It has a small profile and is housed in a small circular body. The negative part is that the amplitude is limited because of the small size. The more notable ERM style is the 'pager'. It has a bigger cylinder shape and is usually used on PCBs where it can be mounted. The LRA models also offer a style of motor with a low profile, but instead of the eccentric mass they use a magnetic mass attached to a spring to drive the motor. Although they can be very quick for response and efficient, they can be more difficult to run.

We decided on the coin vibration motor because of the size and price. They are very price efficient so that it won't affect our overall cost of supplies. Size was a big factor in the decision as well. The 'pager' style ERM would take up too much room in the rangefinder, which we have been trying to keep from being too bulky. With the device being attached to the hand (or handheld) the 0.05 A – 0.1 A will give enough vibration to alert the user.

3.4.6.2. Haptic Driver

Another part to be considered would be to help control the vibration motor. It is the DRV2605 from Texas Instruments. It is a haptic driver that works with either ERM or LRA. This driver comes with up to 100 licensed effects, which we could use to cut the time to design the desired feedback for our rangefinder. It also can be linked with TouchSense 2200 software giving the user 2200 additional effects and audio-to-vibe features. Another feature is real-time playback, allowing the host processor to play waveforms directly from the host through the IC. There is a audio-to-haptics mode, which can convert an audio input into the desired haptic effect. The power needed to run the device is 2.5 V – 5.5 V.

The price of the DRV2605 at TI is \$4.25. Again, through TI we were able to get free samples of the product. It is an inexpensive part though, which is a plus when keeping the rangefinder within budget.

The main advantage of the DRV2605 is the flexible control of either the ERM or LRA being used. The device relieves the processor from producing PWM drive signals, saving timer interrupts and hardware pins. I'm not sure if that will be enough upside for us to use the haptic driver for our rangefinder. Just like the other parts, the power consumption is a big negative, which we might not be able to afford for the upside.

We will possibly have to use our microcontroller (MSP 430) to generate the haptic feedback necessary. The rangefinder needs to have a few different haptic feedback frequency variations to notify the user different distances. Although the haptic feedback driver has many options and effects, the added voltage taken from the device might not be worth it. If the microcontroller can do the job we won't need to use the DRV2605.

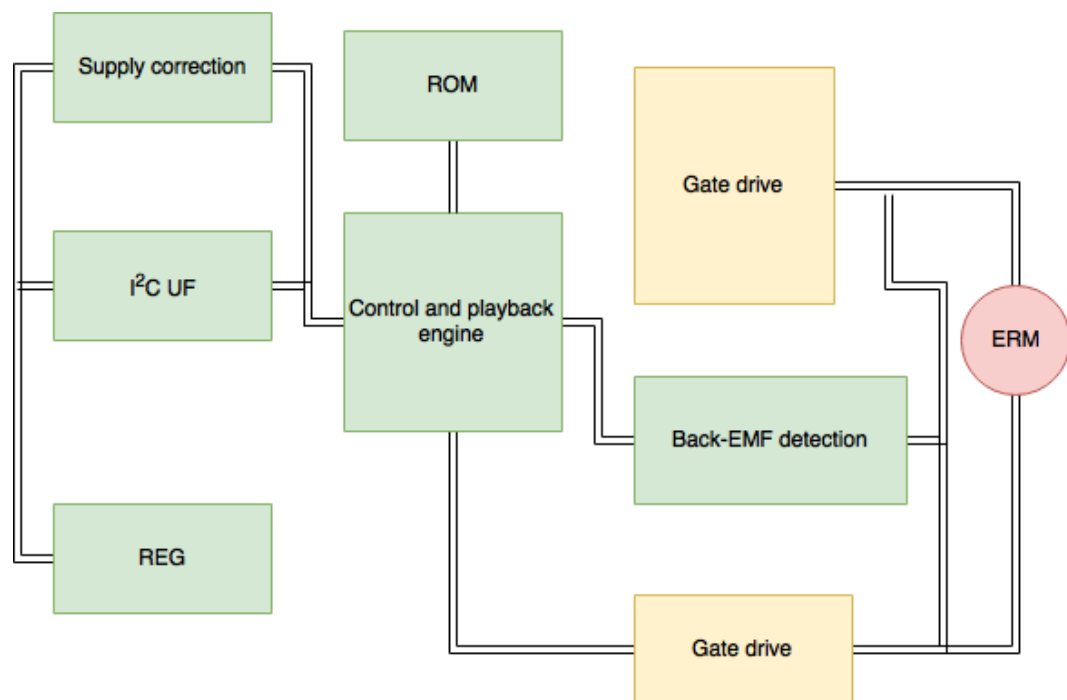

Figure 3.4.6.2 – Haptic Driver

3.4.7. Microcontrollers

The microcontroller will serve as the control unit of the entire project. It is tasked with monitoring the input and output LIDAR signals. It is responsible for reading the signal and interpreting the distance of the object. It is also responsible for controlling the vibration motor frequency in determining the proximity of the object. It would be tasked with, more importantly, power management.

The microcontroller serves as one of the most important components to the project as a whole. The ideal microcontroller would be responsible for a multitude of functions such as: sending and-or receiving the LIDAR signal from the laser, processing and interpreting the data, setting ranges in which it would determine proximity to general objects, sending signals of proper frequency to the haptic feedback system, and managing power. Ideally, the group would like for the microcontroller to be able to handle all of these tasks with relatively high precision and relatively low power, using just one chip. Current research has indicated that this is indeed a possible implementation. However, since one of the main objectives of our project is to make the system as low-cost as possible, more research was needed in not just the hardware of choice, but also the implementation of the code to be used to perform the necessary tasks and still output low-power (due to the fact that this system would be powered via a battery source).

3.4.7.1. Microcontroller Choices

A significant amount of research was done in regards to comparing different brands and models of microcontrollers. A few factors that were used in determining which microcontroller to use were cost and performance. Although some techniques will be used in the reading of the signal to manipulate frequency, the ideal microcontroller would need to have a relatively fast clock signal in order to properly read the signal being received by the LIDAR.

A major part of performance of a microcontroller is the architecture that the microcontroller is built on. The first architecture researched was the ARM architecture. The ARM architecture is a RISC (reduced instruction set computing) architecture. This set of computing is becoming increasingly popular among architectures in that it uses fewer transistors. This alone saves microcontroller manufacturers a significant amount of money. This also comes to the benefit of the embedded and compiler programmers. Because there are fewer transistors, there can be, in most cases, fewer lines of code that can be used to implement similar tasks that other architectures that do not use the RISC architecture would perform. In most RISC architectures, the code is simple and in many cases, very easy to understand and follow.

The ARM microcontroller of interest was the ARM TM4C123GH6PMI. This chip is manufactured by Texas Instruments, a widely known and well trusted

designer/manufacturer of microcontrollers. When considering performance, this particular microcontroller ranks highest among others considered. The clock runs at a maximum frequency of 80MHz with an operating supply voltage of 3.3V. This would prove to have a significant effect on proper reading of the incoming signal (the higher the clock frequency, the greater the accuracy). There is also a large community of dedicated developers on the forum that showed to be a tremendous amount of help in finding ways to implement the code necessary to perform the needed tasks. The cost of the microcontroller is relatively low. However, when considering other components necessary to perform the objective task, the ideal cost of the microcontroller would need to be even lower than this one. Therefore, more research would be needed.

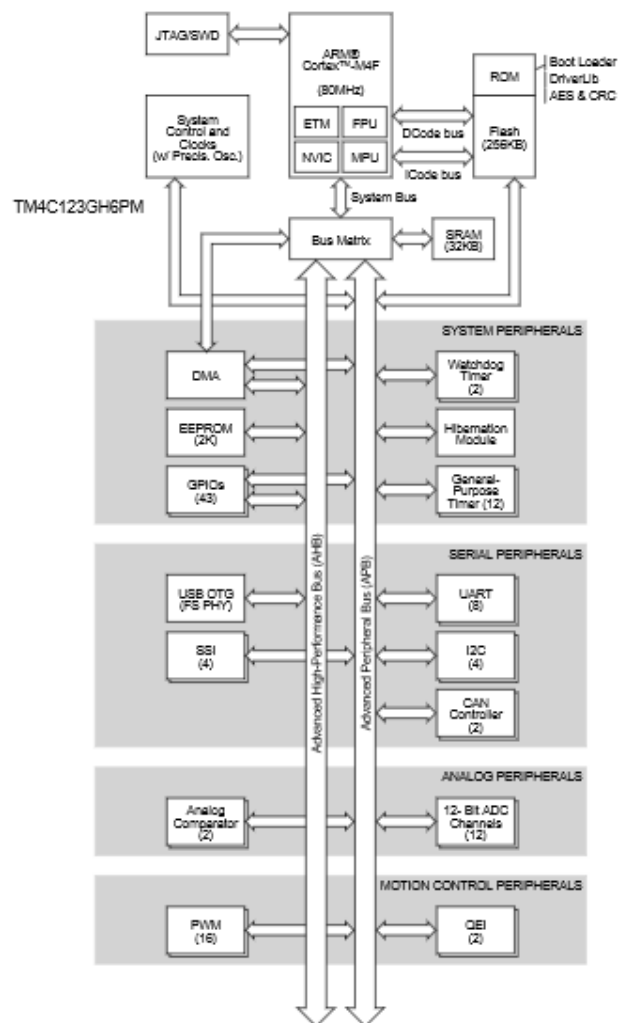

Figure 3.4.7.1 – tM4C123GH6PMI Block Diagram (permission requested)

The second microcontroller considered was the Atmel ATmega328P. A very popular board, the Arduino UNO, is built around this particular microcontroller. This particular chip is an 8-bit RISC machine. What made this unit stand out over others researched was that it contains 23 general purpose input-output lines. This would become extremely useful in being sure that all components in the project had a proper channel to send signals to and to receive signals from. The unit also has a user-selected power saving mode that can be configured with software, making power management more controllable. This microcontroller also allows all of the input-output pins to enable interrupts. Being able to do so would be useful in power management, as using the polling method would be very power consuming. Two parameters that were not met however were cost and clock frequency. The cost of the Arduino Uno R3 (the board that would be used) is significantly higher than what is of interest. Also, the clock can only perform up to 16MHz, which is significantly lower than what is needed for proper performance. An advantage that this microcontroller has, however, is the developer community. The community is very active, and finding techniques to accurately measure signals with this device would not be an impossible task. This microcontroller was considered, but was low in rank.

The next microcontroller considered was the MSP430. This is a very well-known microcontroller among students due to the fact that many electrical and computer engineering students have had experience using a version of this microcontroller. For this particular microcontroller, the MIPS (Million Instructions Per Second) architecture is used. The primary reason for consideration of this microcontroller was the fact that all members of the group has had experience with the board. The familiarity would play to be a huge advantage in the learning and implementation of the proper code necessary to perform the required tasks.

Product	Clock Frequency (Max)	Operating Supply Voltage (Max)	Program Memory Size	Price (per unit)
AMD TM4C123GH6PMI	80 MHz	3.3V	256KB	\$11.42
Atmel ATmega328P	20 MHz	5.5V	32KB	\$5.38
MSP430g2553	16 MHz	3.6V	16KB	\$1.00
MSP430f5529	25MHz	3.6V	128KB	

Table 3.4.7.1-1. Comparison of Microcontrollers Considered

3.4.7.2. Choosing Low Powered Microcontrollers

Choosing a proper microcontroller can be a simple task when using it for general applications. However, choosing the best microcontroller for the particular application requires more consideration in factors such as power consumption. There are quite a number of low-power microcontrollers in the market, so choosing the best one will require looking at electrical specifications and comparing them to one another in order to determine the ideal one. The primary parameter that will be of interest is current consumption. Comparing and selecting the ideal microcontroller based on current consumption can be more of a difficult than expected task. Many designers will look at the first page of a datasheet for their microcontroller of interest and make judgment based on those alone. However, just looking at the first page of the datasheets usually do not provide all of the necessary parameters. When looking at the first part of a datasheet, the type of information usually available is the peripherals, operating speed, number of GPIO (general purpose input/output) pins and power characteristics. This may seem to be suffice when considering overall power consumption; however, there are a bit more parameters the developer must take into account before the research is considered suffice. Some parameters that should also be considered are: current consumption, state retention, wake-up time, wake-up sources, and peripherals that are capable of running in low-power mode. Not all peripherals are capable in running in this mode due to possible high current demand. Some external components in the project require a high current consumption. Therefore, it is crucial to the experiment to minimize the amount of current required for the microcontroller.

Another issue with selecting proper low-power microcontroller is discrepancies in the datasheet. It's becoming more known that vendors of microcontroller will usually list the lowest power achievable on the first page of the datasheet. Although the microcontroller may indeed be able to perform at the given specification listed, there is very little chance that it will be able to perform within those same parameters in real world applications due to the extra current required to power devices. Some of the things not being taken into account when advertising power consumption are wake up times (very slow wake up times may render the microcontroller useless in certain applications), state or RAM retention, or reduced operating voltage range. The job of the developer would be to establish a common operating mode in order to have a consistent reading and to make the developer's job much easier.

Two common parameters developers take into account to compare are electrical specifications and additional low power functionality. For the proper comparison of the electrical specifications, some common things that the developer will look for within the vendor's datasheet include: sleep mode current consumption with state and RAM retention, sleep mode consumption with the real time clock running with state and RAM retention, wake up time, and supply voltage range. Some parameters that the developer will consider with regards to additional low

power functionality are the available wakeup sources, how the code resumes execution, and peripherals that are capable of operating in sleep mode. The last parameter could arguably be one of the most important ones to consider, as the more peripherals that can operate in sleep mode will have one of the largest effects on minimizing the current consumption.

3.4.8. Software

Earlier, power was discussed with regards to hardware parameters. However, as important as hardware is when considering power consumption, it is just as important to consider the software component of the design. As one is well aware of, there are multiple considerations to be made when making decisions on the software component of the experiment. Some ideas to take into consideration are the language to use (assuming the software environment allows for developing in other languages) and software techniques (ie. loops, interrupts, arithmetic/logical operations etc.). Other important factors to take into consideration are the efficiency of the compiled code, program maintainability, and familiarity with the language of choice.

In all of the microcontrollers being considered for the design, all of them have the ability to be programmed in environments compatible with both C and assembly language. TI's Code Composer Studio allows for development in both languages for each of them. One must note that although the Arduino UNO is not normally programmed in this environment, it is possible to use it. The Code Composer Studio software comes with an extensive list of libraries; with the majority of them containing a plethora of pseudo-code for whatever microcontroller that will be used for development. The use of pseudo-code is very useful in that it helps the developer control parts of the microcontroller without the need to research the memory addresses associated with each component. Though the developer has the option to develop code using memory addresses, he/she does not have to. It is also not recommended due to the possibility of writing to the wrong memory address and causing potential issues with the microcontroller.

There are many benefits of using the pseudo-code in Code Composer Studio:

- Ability to set/clear bits by using BIT_X (X being the particular bit)
- Simple control of clock sources
- Defining/writing to/receiving from individual or multiple GPIO pins

All of the above functionalities would be significantly more difficult if the developer would be required to know the memory locations for each section of the microcontroller that wanted to be used. Not only would time be wasted researching these locations, the probability for error would become significantly higher; which would also extend the amount of time spent debugging the software, due to the possibility of not knowing exactly where to find the right memory location for the part of the microcontroller being controlled. There also

runs the risk of the code compiling without error, but producing undesirable results upon running the program. Due to time constraints in the planning and implementation of the software for the project, it is most recommended to consider using the language that has sufficient pseudo-code.

3.4.8.1. C Vs. Assembly

Though there is still a debate on whether C or Assembly language is ideal for microcontroller programming, the majority of today's research shows that the difference between the two has almost no effect on efficiency. Below are some common parameters that are important to microcontroller programming.

	C	Assembly
Efficiency		X
Ease of Learning	X	
Common	X	
Memory/Hardware Control		X
Portability	X	
Compiler Efficiency	X	X

Table 3.4.8.1-1 – Comparison of C vs Assembly

One will notice that most compilers are as efficient in C as well as assembly. Assembly language has the advantage of overall efficiency with regards to speed of the program. This is due largely to the smaller amount time needed to convert the code to machine code before loading. C however, is considered better in efficiency with regards to the size (number of lines) of the code. C is also considered easier to learn than assembly, as it allows the ability to create more complex functions compared to assembly. Though most functions can be implemented with assembly, the amount of code the assembly would be required to have compared to C in order to perform the same function can be significantly larger, depending on the complexity of the function. C is also more common amongst programmers. One will see that the majority of higher-level languages are derived from the C language.

The assembly language does have a significant advantage with directly controlling the memory, and other hardware. Since assembly is the foundation of the microcontroller, there are more functions that can be used to directly control memory based functions. In regards to portability, the C language is the clear winner. The one big issue with the assembly language is that there is very little compatibility between one microcontroller and the next. Also, if new instructions are to be implemented, it would only be compatible to the microcontroller that would need to be redesigned in order to be compatible with the newly implemented function. C, on the other hand, does not have the same issue; hence why it can be used across multiple devices with very little change to the

code. With there being fewer assembly programmers compared to C, there is a smaller community of assembly programmers. When dividing this number by the hundreds of different microcontrollers available, most of which requiring a different version of assembly, this community becomes even smaller. It would seem as if choosing to program in C is a no brainer. However, it is fortunate enough that two of the microcontrollers that are being considered use the same style of assembly programming, the MSP430G2553 and the MSP430F5529.

Since electrical engineering students at the university have had extensive programming experience in MSP430 assembly language, it is definitely worth consideration. In the case of the MSP430, there is similar pseudo-code available in both C and assembly languages. Therefore, it is still worth considering both for implementation. The final decision will be primarily based upon energy consumption, since that is a very high priority for the project.

3.4.9. Communication Protocol

The most important part of ensuring the successful operation of the program is the ability for each of the components to properly communicate with the pins of the microcontroller and for the microcontroller to communicate with the peripheral devices. It is imperative that when considering the method of communication for the microcontroller, one must give priority consideration to the compatibility of the method of communication between the microcontroller and its peripherals. For implementation of the current project, the three methods that are being considered are three of the most popular methods being implemented in current technologies. Please note that the methods being considered are for wired communication. Wireless communication will not be used as it has no need in the project being implemented.

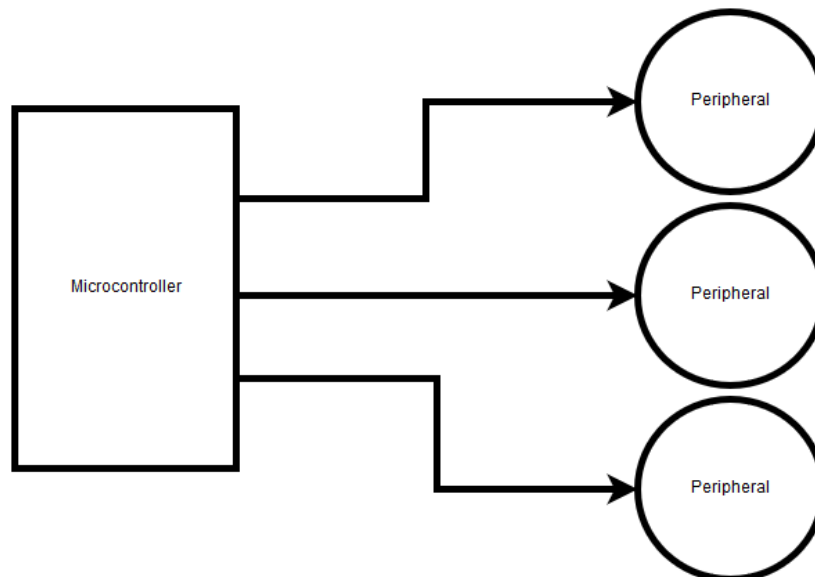

Figure 3.4.9 – Microcontroller/Peripheral Interface

3.4.9.1. Serial-Peripheral Interface

The first communication device being considered is the Serial-Peripheral Interface (also known as SPI). This type of design is very common amongst embedded systems and is considered a standard amongst short-range wired communications, with its debut in the 80s by Motorola. Its most popular application is with liquid crystal displays.

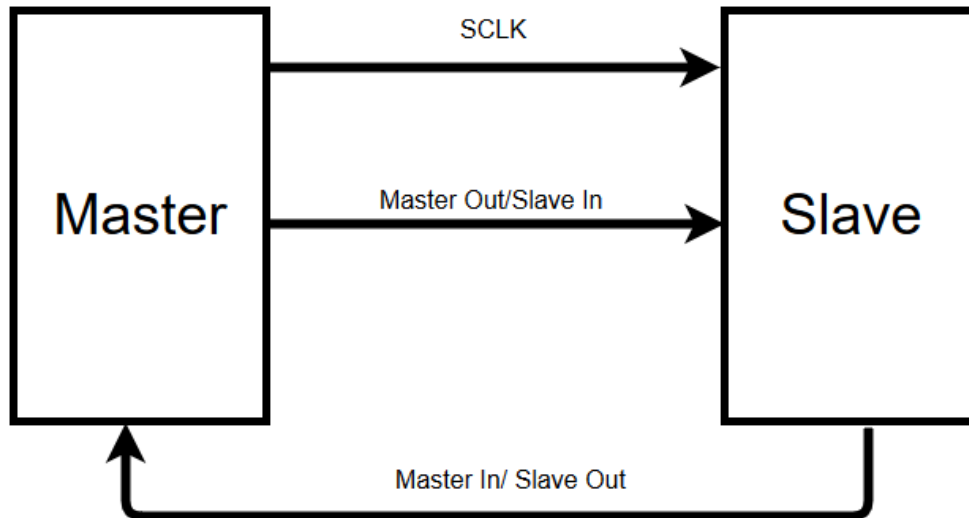

Figure 3.4.9.1-1 – SPI Master/Slave Interface

The mode of data transmission is commonly known as the master/slave transmission; with the sending end being the master and slave end being the receiving end, typically. The starting of communication usually begins with the master end configuring a clock that is supported by the slave. This clock is usually within a few MHz. In the event that analog-to-digital conversion is necessary, a waiting period will be implemented before issuing out clock cycles. During each of the cycles, a full duplex data transmission is occurring. Some common applications that utilize SPI are:

- Sensors
- Control devices
- Camera lenses
- Communication (such as Ethernet, USB, etc.)
- Memory (flash and EEPROM)
- Clocks (real-time)
- LCDs
- SD cards

The benefit of utilizing SPI configuration is the ability to control multiple slaves in synchronization with the master. There are two main configurations in regards to this configuration: the independent slave configuration, and the daisy chain configuration. The following figures show the configuration for both.

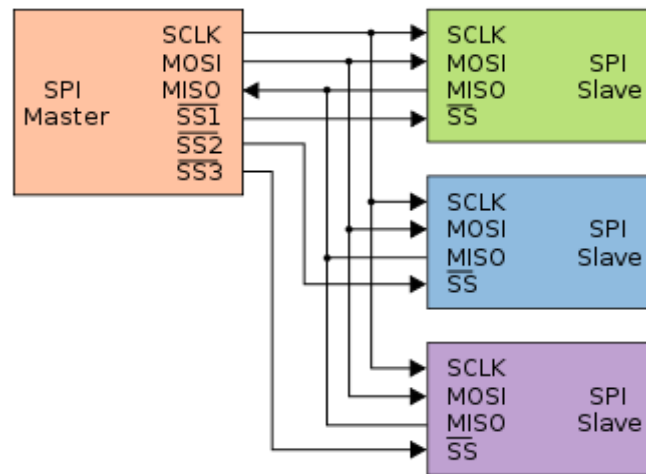

Figure 3.4.9.1-2 – SPI Independent Slave Configuration (permission not needed)

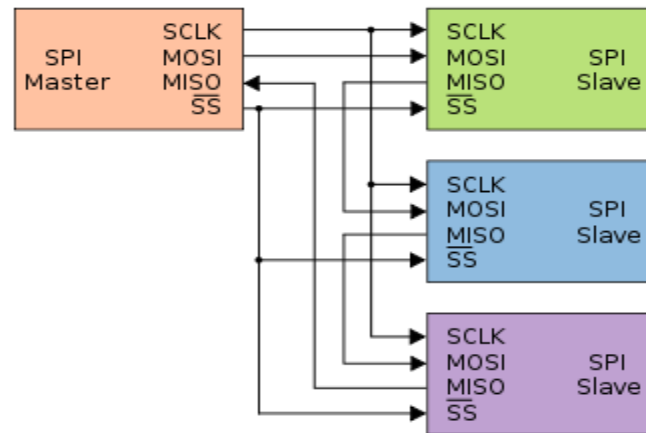

Figure 3.4.9.1-3 – SPI Daisy Chain Slave Configuration (permission not needed)

Some advantages of using SPI over other methods are:

- Good signal integrity and high speed
- Highest max rate of processing speed
- Greater than 8-bit words are able to be processed
- No precision oscillators needed (since slaves use the master's clock)
- No unique addresses needed for slaves
- Flexibility with regards to message size and content
- Flexibility with regards to word-size
- Simple software implementation
- No limits on max clock speed

Since LIDAR technology requires very high speeds (though our application will likely implement down-conversion to deal with that demand), having no limit on the maximum clock speed will show to be extremely beneficial in future. It is of hope that this project is continued beyond the prototype phase. If it becomes so, a processor with more speed will be required in order to maximize precision. Though there are a ton of benefits with using this method, it does not come perfect. Here are a few disadvantages with using this design:

- Interrupts not possible unless out of band or faked
- Can only handle short distances
- No hardware slave acknowledgement (master could transmit nowhere and there's no way to tell)
- Likewise, there's no error-checking protocol
- No formal standard (no way to validate how well the product works)
- Requires more pins than the others

It's noticeable that there are some considerable drawbacks in choosing this particular implementation. However, these drawbacks should not be so significant that they affect the overall performance of the system.

3.4.9.3. UART

The second considered communication implementation is the Universal Asynchronous Receiver/Transmitter (UART). It is unique in that it takes the bytes from the data of the transmitting end and sends the data to the receiving end one bit at a time. Once the data reaches the receiving end, another UART re-assembles the bits into complete bytes. The makings of UART are similar to that of a shift register. It contains similar workings in regards to the movement of the data. For UART, data transmission typically begins with the sending end transmitting a start bit. After successful transmission of the start bit comes the data bits. These bits are then proceeded with an optional parity bit, followed by a stop bit. The following figure below shows a model illustrating the UART transmission process.

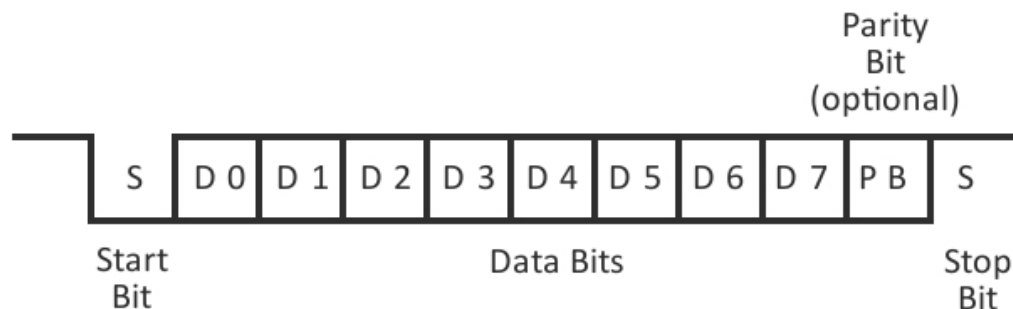

Figure 3.4.9.2 – UART Data Transmission Diagram (permission not needed)

This implementation is very common amongst the electrical engineering students at the university. The Embedded Systems laboratory experiments exposed the students greatly to interfacing with UART. This is one of the reasoning as to why this implementation is being considered for the system.

Inter-Integrated Circuit

The third protocol being considered is the Inter-Integrated Circuit, or known shortly as I²C. This protocol was invented by Phillips Semiconductors and features a multi-master, multi-slave configuration. This configuration is typically used for attaching low-speed peripheral integrated circuits to microcontrollers over short distances. The design for this is fairly simple; using just two bidirectional lines, a serial data line, and a serial clock line. Each master and slave is connected to the serial data line and serial clock line, which these lines are connected to the voltage with the use of pull-up resistors. The figure below shows an illustration of a sample schematic for the described design.

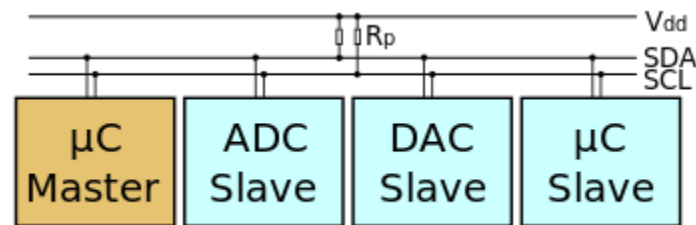

Figure 3.4.9.3 – I²C Master/Slave Schematic (permission not needed)

The protocol for data transmission is dependent on one of three possible configurations. The first configuration would be for the case where the master writes data to the slave. The second, being the case where the master reads data from the slave. The third, being a combination of the first two. In this case the master will have at least two reads and/or writes to one or more of the slaves. Having this particular protocol would be useful for applications where writing multiple signals would be required. The only downside, which could ultimately be a deciding factor amongst choosing this particular protocol, is that the peripherals that communicate with the devices must be of low frequency. As previously stated, our application specifically demands compatibility with high-frequency/very-high frequency speeds.

3.4.10. Single Board Computer

It is important to establish a clear definition of a single-board computer and the difference between it and a microcontroller. A single board-computer is built onto a single circuit board. It contains the microcontroller's memory, input/output, and other peripherals required of the particular computer. These units are widely popular for development, educational settings, as well as embedded computer controllers.

A single-board computer differs from a traditional desktop computer in that it usually does not have the same performance specifications as a desktop computer (desktops usually perform much faster). Single-board computers typically do not require memory expansion, as they are normally designed for a specific level of performance without significant modifications. One of the primary benefits of using a single board computer is the smaller size. Because these units are typically small, they are able to be used for multiple applications such as household appliances and automotive applications. They are widely popular for use in embedded systems.

The board of choice upon researching possible SBC's for the ATmega 328P was the Arduino Uno. This is a more common board amongst hobbyists as well as professionals. The Uno has 14 digital input/output pins in which 6 of them can be used for pulse width modulation. It also contains a 16 MHz quartz crystal. The Uno is unique in its durability and ease of part replacement. The chips are easily replaceable in the event that it gets damaged.

In researching the MSP430, there were two possible choices for consideration: The MSP430F5529 and the MSP430G2553. The F5529 board has an advantage over the G2553 in many categories. The frequency of the F5529 is much higher than that of the G2553. It also has a significantly larger number of general purpose input-output pins, which gives much more comfort room, should the project call for the use of more pins than expected. Having a smaller number of pins on the G2553 will be a significant risk in that case. Also, the F5529 has two UART pins compared to the one on the G2553. Though it seems that the F5529 should clearly be considered over the G2553, since one of the parameters is to make the system small, it would be ideal to be able to use the G2553 if a method is discovered on how to maintain the required level of accuracy with a slower clock.

SBC	Clock Frequency	Timing Module Available	Input/Output Pins	Price
Arduino UNO	16MHz	no	14	\$24.95
MSP430G2553 Launchpad	16MHz w/ 32kHz crystal	yes	14	\$9.99
MSP430F5529 Launchpad	25MHz	yes	40	\$12.99

Table 3.4.10 – SBC Comparison

4.0. Related Standards and Realistic Design Constraints

4.1. Standards Section

Along with the specifications that we have assigned to our project for it to work correctly and remain safe to the public, there are specific standards placed on the project, and all projects made, that are required in order to keep the project up to a certain quality. There are groups that create standards such as IEEE and ANSI that work on designing standards to promote safety, reliability, productivity, and efficiency. Standards play a fundamental role in making sure products are produced for customer satisfaction and to keep an eye on public safety concerns. Standards are so ingrained in products and technology out today that we take for granted the benefits of having this system in place. For instance, in the manufacturing of products their needs to be standards to keep certain parts, which require a counter part, to be compatible. If a product that requires electricity has a plug to go into an electrical outlet it must have the correct plug to work in every outlet as a standard. A bolt in made in Florida will work with a nut made in California. Cars need to have a standard for tire pressure and how wide the body frame can be to fit on the road. Light bulbs must have a standard size to screw into a every lamp. There are examples of standards everywhere you look in the world and for every product. For our project in particular there needs to be standards when using lasers. This is a big deal because if used the wrong way someone could be blinded. These, and other potentially dangerous components in products, must be kept to a certain standard for public safety. If the wrong parts or power is used and a laser potentially causes someone to go blind then the original purpose of the product is pointless.

Standards are first taught to us in college through ABET. ABET accredits the college and ensures the graduates and future engineers are ready to enter the workforce with a knowledge for quality standards.

The standards reviewed below were first created through a Standards Development Organization. The process to make a standard is fair and objective, with a focus on high quality and market relevance. Time-tested platforms, rules, governance, and methodologies are used to help facilitate and develop the standards available today. Standards are not actually mandatory but serve as guidelines, unless they are added into a business contract or some sort of regulations. With that being said, with standards cost can be brought down and training can be simplified. They are so effective because of the commonality across the board in industry.

In the section following Standards, we go over constraints that limit our project. When designing the rangefinder we need to consider these factors that might limit us in the end. There are several types of constraints on a project like

this including, but not limited to, design, economic and timing constraints. These three are the main constraints we focused on while developing the project so far.

4.1.1. Related Standards

The standards we searched for, related to our project, are listed below. We will use this information for the design and build of our project to make sure it is up to the highest quality. Our laser rangefinder will require a laser, avalanche photodiode, ERM motor, power distribution from a battery source, Time-to-Digital convertor, direct down converter, a microcontroller, and software to connect each.

- 647-2006 – IEEE Standard Specification Format Guide and Test Procedure for Single-Axis Laser Gyros. This standard includes a compilation of ways to test an RLG. Measuring systems are defined for angular displacement and angular rate.
- 802.15.7-2011 - IEEE Standard for Local and Metropolitan Area Networks-Part 15.7: Short-Range Wireless Optical Communication Using Visible Light. Focuses on short-range optically transparent media. This standard adheres to valid eye safety regulations. It will supply data rates with compatibility to visible light setups.
- CAN/CSA E60825-1-2015 – ANSI Safety of Laser products. Applicable for lasers emitting radiation in range of 180 nm to 1 mm. The laser product may be combined in a complex optical, electrical, or mechanical system. Other than the potential exposure to laser radiation, other hazards, such as high or low temperatures, electricity, and chemicals. Laser radiation can cause temporary visual impairment. Class 3B and Class 4 laser product may not be suitable for the public.
- IEC 60825 - Safety of Laser Products Package. Requirements on safety and uses of various laser equipment provided. Suitable for manufacturers of laser products including, but not limited to, consumer products. A system of classification for wavelengths ranging 180nm to 1mm in order to prevent any radiation hazards. Provides a system of warning labels and instructions to help mitigate injury. The standard also introduces a new class, Class 1C.
- ISO 12609-2:2013 – ANSI Eyewear for protection against intense light sources. This standard gives safety advisory for eye protection with lasers on humans and animals for cosmetic and medical applications regarding prolonged exposure to optical radiation in the 250 nm to 3000 nm spectral ranges.
- BS EN ISO 11252:2013 – ANSI Lasers and laser-related equipment. Minimum requirements for documentation. Explains what the minimum documentation requirements are for lasers and laser diodes.
- BS EN 165:2005 – ANSI Personal eye protection. The standard covers multiple eye protection requirements, but includes eye protection used

against laser radiation, and protection for adjustment work on lasers and systems using lasers.

- IEC 61326-2-2 Ed. 2.0 b:2012 – ANSI Electrical Equipment for measurement, control, and laboratory use. For low voltage distribution systems powered by battery, giving test configurations and operational conditions.
- 1729-2014 - IEEE Recommended Practice for Electric Power Distribution System Analysis. This standard reaches out to the space of software developers, software users, and researchers. It details load response to voltage and frequency, neutral-earth voltage, interoperability, etc. Recommended practice for distribution systems in the medium-voltage range.
- 1547.7-2013 - IEEE Guide for Conducting Distribution Impact Studies for Distributed Resource Interconnection. Provides substitute methods and good practices for engineering analyses of the potential impacts of distributed resources consistent to the electric power distribution system. For distributed resources and electric power systems, study scope and extent are described here. For distributed resources, the standard also identifies what findings should be performed based on technically transparent standards.
- C18.2M Part 1-2013 – ANSI Portable Rechargeable Cells and Batteries – General and Specifications. This standard is set up for secondary cells and batteries. This includes nickel cadmium, nickel metal hydride, and lithium ion. It includes general information as well as standardized performance and testing procedures.
- C18.2M Part 2-2014 – ANSI Portable Rechargeable Cells and Batteries – Safety Standard. With regards to part 1, this standard goes over the same types of cells and batteries, however part 2 goes over safety tests and requirements.
- IEC 61000-6-3 Ed. 2.1 b:2011 – ANSI Generic standards – Emission standard for residential, commercial and light-industrial environments. This standard pertains to apparatuses battery operated or is powered in low voltage power distribution system. Particularly in residential, commercial, and light-industrial locations, indoor and outdoor, environments. The standard focuses on the emission test requirements and making sure the emissions coming from the product do not thwart other apparatuses from functioning properly.
- IEEE Std 1241-2010 – IEEE Standard for Terminology and Test Methods for Analog-to-Digital Converters. When using analog-to-digital converters, this standard supplies the common terminology and test methods. It specifically focuses on analog-to-digital converters that are quantized.
- 1118.1-1990 - IEEE Standard for Microcontroller System Serial Control Bus. This standard explains methods for connecting microcontrollers to one another using serial control buses. It provides a multidrop bit-serial communication protocol for connecting two manufactured devices.

- 24765-2010 – IEEE Systems and software engineering – Vocabulary. This standard provides a standardized vocabulary for software engineering work. It takes current and looks at future terminology to uphold clearness in programming vocabulary.
- UL 61010-031-200x – Electrical Equipment for Measurement, Control and Laboratory Use. Safety regarding hand held probe assemblies for electrical measurement and testing are standardized by UL. This pertains to electrical equipment, measurement, control, and laboratory use.
- 15288-2015-IEEE: Systems Life Cycle Processes establishes a general framework for the development of human created systems. This standard goes into full cycle of a process.

4.1.2. Design Influence of Relevant Standards

Standard CAN/CSA E60825-1-2015 gave us guidelines for wavelengths for picking a potential laser for our project that will remain safe to the public. We used it for understanding the risk of potential visual impairment and informing us to stay away from Class 3B and Class 4 lasers. IEC 60825 - Safety of Laser Products Package as well reinforces this same standard. Another standard along the same lines of laser safety is ISO 12609-2:2013 – ANSI and helped us focus on the importance of using eyewear when testing or in the vicinity of someone testing lasers. The standard informs individuals to limit exposure to optical radiation in the 250 nm to 3000 nm spectral ranges, which we kept in mind. Standard BS EN 165:2005 – ANSI further gave us multiple different eye protection requirements, and we learned the importance of protection while using and adjusting laser systems.

Standard IEC 61326-2-2 Ed. 2.0 b:2012 is useful to us as we work in the lab. As we test our project we will need the outline of the standard using low voltage distribution systems. Some equipment this standard focuses on can include, but is not limited to, the oscilloscopes, logic analyzers, spectrum analyzers, network analyzers, analogue instruments, digital multimeters, and board test systems. The C18.2M Part 1-2013 standard is considered with our potential power source. We have considered the use of a lithium ion battery. The standard helps to ensure interchangeability of these products with being manufactured at two different locations. The standard performance has been tested and assessed. All of the information is provided with guidance to end users, consumers, designers, and manufacturers. Part 2 is necessary for the safety information so the product is not used in any hazardous manner, or used in a way that's produces a hazardous result.

The IEC 61000-6-3 Ed. 2.1 b:2011 standard works with our project because of the focus on a product that is battery operated and uses low voltage power. Since our product would potentially be used in residential, commercial, and light-industrial locations, indoor and outdoor environments, the standard applies to us. Emission requirements recommend frequency range between

range 0 Hz to 400 GHz. If a dedicated EMC emission standard is not put in place, the generic EMC emission standard is applicable. These guidelines are to ensure one product's output does not impede on another product preventing it from functioning correctly.

We will be using analog-to-digital converters in our project. The IEEE Std 1241-2010 standard was made for the testing of analog-to-digital converters. If the analog-to-digital converter is not quantized, this is the standard supplies method for testing the ADC.

There is a standard with regards to the msp430 we will use in our project. The 1118.1-1990 standard can provide us with connection methods using serial control buses. It provides us protocol for instrumentation, distributed data acquisition systems, control devices, and test and measurement.

The UL 61010-031-200x standard brings us back to overall safety that will be needed in the project. We will be in a lab testing with electrical equipment and the UL 61010-031-200 can help with the process as a general safety guide.

Lastly, we look at the 15288-2015-IEEE standard. As a group working on a project of this size, we need to communicate effectively and work together as a team to be successful. This standard goes into full cycle of the process to complete our project. At the beginning of the semester we were instructed by our professor to brainstorm ideas until we would decide on a proposal. After this step, we progress to the research, design, and testing. This standard demonstrates the total cycle it takes to the documentation and then presentation at the end.

4.2. Realistic Design Constraints

If a blind or visually impaired person were to walk around with a 10-pound device on his/her arm they would probably not want to wear the device that long, or at all. When designing our rangefinder we had to think of this and other design constraints. It obviously needs to be lightweight. We decided on a certain size for the overall package. This opens up another constraint with how many electronic components that we can fit in the packaging. There is a power constraint because of this same reason. We had these constraints in mind when designing. This does not include the health and safety constraints that are involved with using a laser. That is obviously another big concern.

4.2.1. Economic and Time constraints

Our group has been funding our own project completely without the help of a sponsor. Because of this economic constraints will play a factor. Luckily, as electrical and optical engineering students, the parts we have obtained have not been that expensive. Without being said, we still had limits to what we were able to get. There are higher quality parts that would have improved our project

overall, however because of the economic constraint we had to settle for the parts within our budget.

Time is an obvious constraint not only for us as students, but also for everyone in the real world. We have a deadline for each part of our project to insure we won't fall behind. To research, design, and document a project like this there are many steps and details to accomplish. Overall, the time constraint is 5 months total. Our first semester is set for research, design, and documentation. The second semester we will have to implement the design and create a working part. Doing all this we have to plan for the time constraints present.

5.0. Design

The following section is dedicated to showing the process in which we as a collective have chosen to design the individual sections of the project. The methods that were considered then implemented were that of each individual member of the group. The process of integrating each section of the project is currently in motion.

5.1. Device Operation

The operation of the device as a whole consists of a series of modules designed by different member of the group. The device serves a purpose of aiding the blind in detecting when objects are within a certain range that would require the user's attention.

It will consist of the following sections:

- Power Supply Unit
- Microcontroller Unit
- Timer Module
- Laser Module
- Optical Module
- Receiver Module

In this design, the power supply will power both the microcontroller unit and the timer module. The microcontroller will have the responsibility of interacting with the timing module to ensure proper timing in the system before interacting with the laser module. The laser module will have the responsibility of sending a signal out to the optical module that will determine whether an object is within a particular distance, which will send this information back into the receiver module. The information obtained from the receiver module will be relayed back to the microcontroller, which will in turn control the haptic feedback system. The haptic feedback will be the method in which the user will know whether they are in a particular distance from the object. This feedback will be frequency-controlled. Currently, there will be three speeds to determine whether an object is

of close, medium, or far distance. Figure 5.1 shows a generalized schematic of the design.

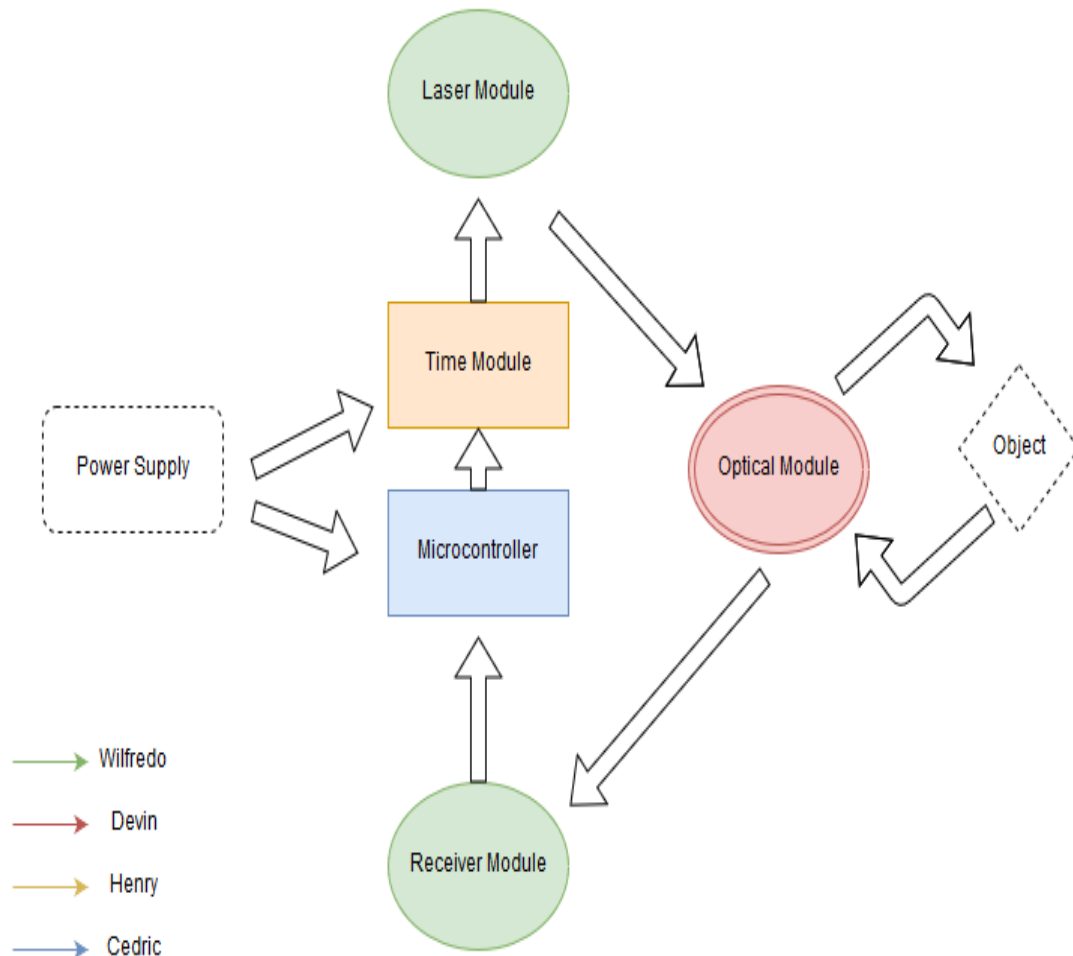

Figure 5.1 – Project Block Diagram

5.2. Power

One of the things that has to be taken into account when deciding on the method of power is the drain rate of each implementation. Since the power source being used is limited and the amount of time the battery will be used for must be maximized, this particular factor must be high on the list of considerations when determining the ideal component. The current method of testing determines the amount of power that will be drained from the battery source over the time of 30 minutes. Data points will be collected over the period of 1 minute, 5 minutes, 10 minutes, and 30 minutes. Although the final testing will probably not consist of 30 minutes (when testing the final product itself), it is good to have a general idea of the drain rate of an unloaded system so that a generalized idea on which method

would be best suited can be obtained. For this test, a 9V Sunbeam® battery will be used with a connector that allows for use on a breadboard. It will be compared with a set of 3 1.5V Carbon Zinc AAA batteries from Panasonic®. These batteries are connected in series using a battery holder with output pins that allows for use on a breadboard.

It is to be mentioned that due to the number of components the power source will be responsible for, there may be a need for more than one battery. Testing the drain rate of the batteries helps in determining which battery will be best as the goal would be to minimize both the size of the battery as well as the number of batteries that will be used.

5.3. Hardware

In the current testing phase for the microcontrollers; both the MSP430G2553 and the MSP4304F5529 will be utilized for further comparison in regards to the battery consumption and timing. It is beneficial that the Launchpad will be used, primarily due to the fact that the majority of the components on the Launchpad are labeled, which makes for simple use with programming and also figuring out the purposes of each individual pin. Since both boards being tested are from the same company and are also similar in architecture, both can be tested in the same software environment. Also, due to the similarities in both boards, most of the same pseudocode can be used for either board.

The first objective was to find a proper way of powering the board without utilizing the USB port on the microcontroller. Due to the nature of the intended use of the project, it would not be in the best interest to keep the device connected to the computer while performing the necessary tasks. The first idea that came to mind was a battery holder. The ideal battery holder would be able to hold a number of AAA sized batteries, allowing for batteries in the range of 3V-4.5V (3V for the case of using only two AAA batteries and 4.5V for the case of using three AAA batteries). Another idea would be to utilize a 9V battery with a special wire head attachment that would allow cables to be pinned into the breadboard. A pair of resistors would be utilized to obtain the voltage desired to power the board. For example, if a voltage of 3.3V-3.5V is desired, a simple voltage divider can be applied to the input (battery) to get the desired value. Finding the required resistor values will be possible by applying the voltage divider equation:

$$V_o = \frac{R_b}{R_a + R_b} V_i$$

Where, R_b represents the load resistor that will supply the input voltage to the microcontroller. So if the desired voltage is within the range of 3.3-3.5V, then selecting R_b as 1kΩ will require a resistance R_a of 1.571kΩ - 1.727kΩ. Being able to obtain the exact resistor values would not be possible for the design for the following reason: the values of the resistors are not standard; therefore they would need to be added in a way such that they achieve the desired voltage.

This would not be a major issue if the overall design did not depend on size. In our project, size is a critical component; therefore, the number of components must be kept to an absolute minimum in order to maximize the portability of the product. The table of standard resistor values shows that the two only options for the resistance value of R_b would either be $1.5\text{k}\Omega$ or $1.6\text{k}\Omega$. The following figures show both the schematic of the voltage divider that is intended to be used for the project; showing the output voltage for the case of using the ideal resistor value and for the one that will be used for the actual design.

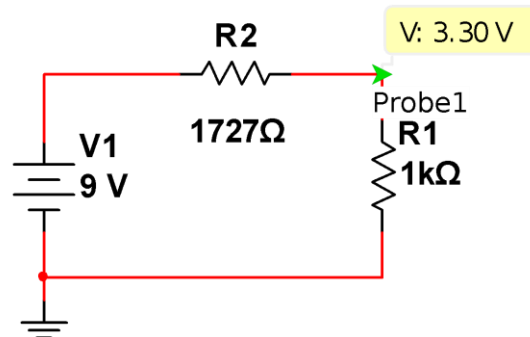

Figure 5.3-1 – Voltage Divider (Ideal R Values)

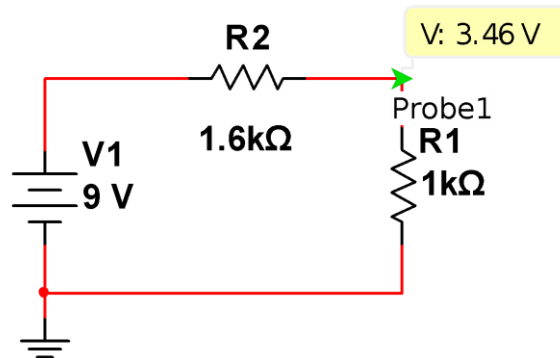

Figure 5.3-2 (real R values)

Notice that the output voltage lies within the ideal operating range for powering the microcontroller.

5.3.1 MSP430 Low Power Modes

As previously stated, the MSP430 has the option of enabling low-power modes. The purpose of this is to minimize power consumption by disabling certain clocks within the single board computer. This will be another factor in maximizing the whole system's portability. The system will be tested under each of the low-power modes in order to determine which one will be utilized. The idea is to use the one that requires the fewest clocks to minimize the battery consumption since the device will be portable.

5.3.2 Pin-to-Buzzer Feedback Design

As previously stated, one of the output pins on the microcontroller will be dedicated to controlling the haptic feedback system. This will serve as a key element in assisting the user with detecting relative proximity of a particular object. The haptic feedback currently being tested is a basic buzzer that is activated if a voltage is applied. The intensity of the buzzers depends on the amount of voltage being supplied to them. Implementing a single buzzer was the ideal scenario; however, due to size, it would be more ideal to implement more buzzers in the design. We want the user of the device to be able to notice the vibrations; the initial run will test with three buzzers. The microcontroller will send a signal through three separate resistors through the buzzers. Doing so ensures that only one pin is utilized while each buzzer receives the appropriate signal.

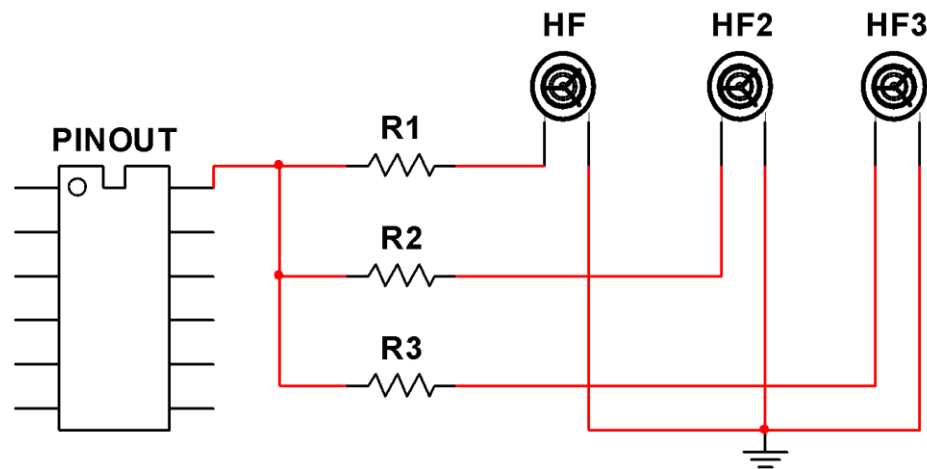

Figure 5.3.2 Proposed Feedback Buzzer Design

5.4. Software

The following sections describe the current goal, as well as the current test plans for implementation of the software for the different functions that are of interest in the project as a whole. Due to the nature of the project, the software will play a vital role in the processing of information, as well as the managing of the various power source(s) that will be used. For the current testing phase, both C and assembly will be utilized. Several factors such as processing time/processing speed, battery use, and accuracy will be considered in the testing phase to determine which code will be the most efficient to use for the system.

5.4.1. Polling Vs. Interrupts

There are two types of interrupts that will be being tested for the purpose of conserving battery. As stated previously, the MSP430 is capable of reading signals via polling method or interrupt method. The two figures below illustrate the polling vs. interrupt methods that are currently being considered. Below is a schematic of the polling method considering being used for the design.

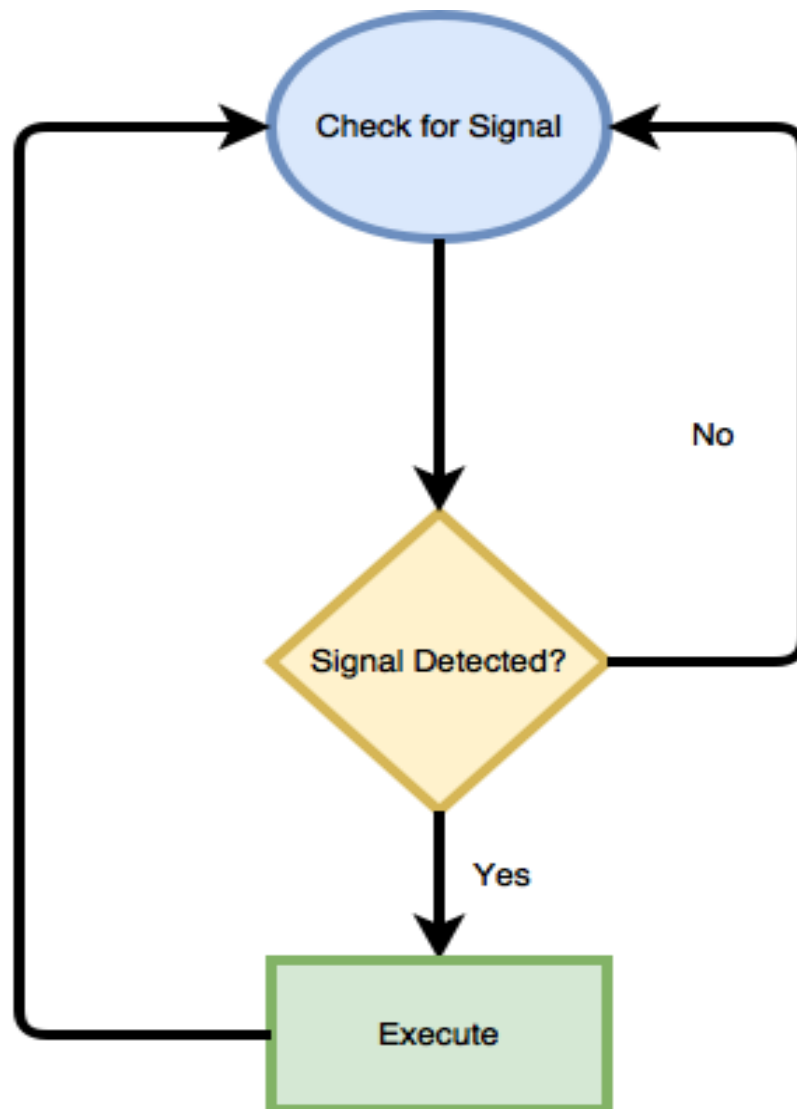

Figure 5.4.1-1 Polling method design

In the polling method, the check signal/ signal detected loop will execute indefinitely. This is implemented with the use of an infinite for loop. During each iteration of the loop, the code will check whether a signal has been detected. If the signal has been detected, the function to calculate the signal difference and send information to the haptic feedback/buzzer system will execute. If this signal

has not been detected, it will not execute, but will continue to check until one is detected. As one can see, this method will be less efficient on battery, due to the fact that the clocks will never go to sleep. However, if we are able to achieve a design that uses a significantly low amount of power, the polling method would be able to be implemented. Below is a schematic of the interrupt method that we are considering using in our design.

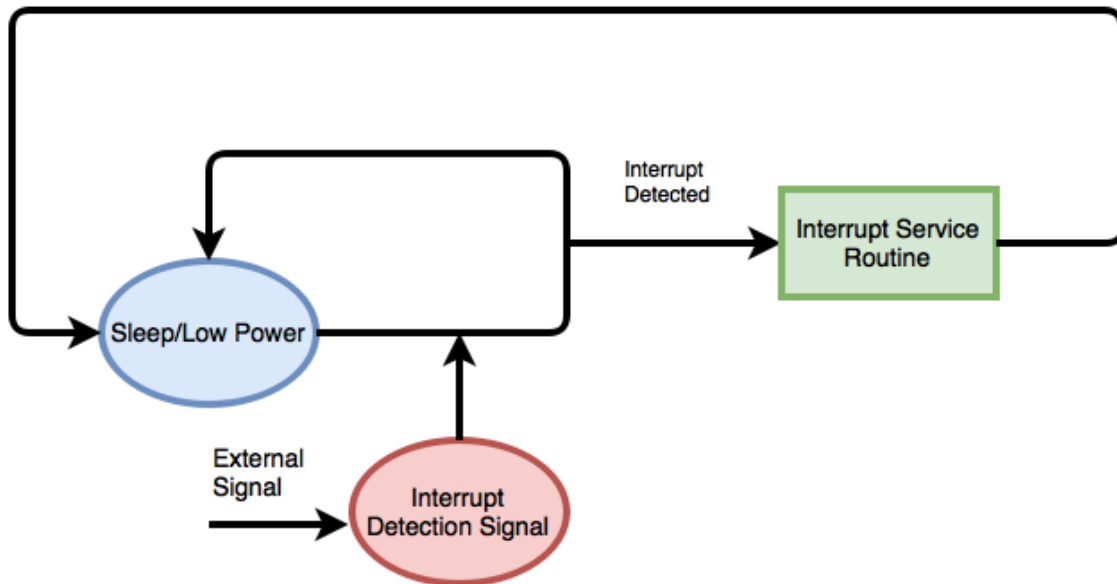

Figure 5.4.1-2 - Interrupt method design

The interrupt method, though more complex in structure, proves to be the most battery efficient method as parts of the code will execute a significantly smaller amount of times. However, being able to obtain a design that is efficient enough will require less of a need to consider this when testing. The polling method will be convenient in the testing procedure in that it allows for more control of the flow of the program and relies less on the hardware to detect the signal and process accordingly. One thing that needs to be considered is the possibility of the program not being able to properly read the signal due to the time it takes for the hardware to wake. If this shows to be a problem during testing, the polling method will be the choice.

5.4.2. Pin-to-Buzzer Feedback Software Design

Below is a representation of the software design for controlling the buzzer feedback.

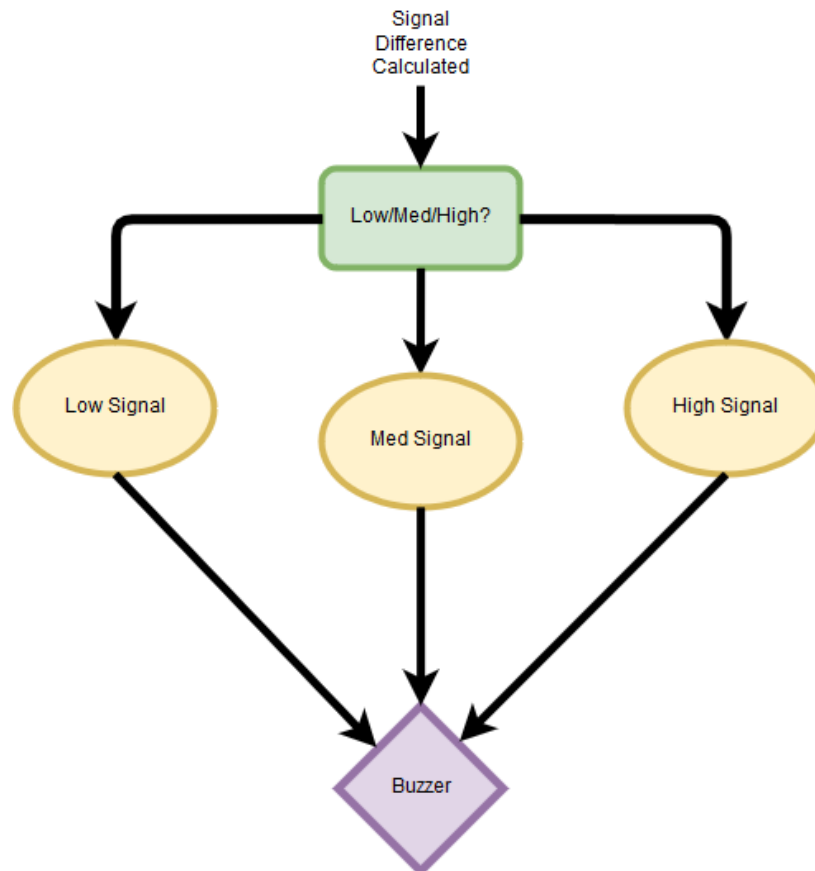

Figure 5.4.2 – Pin to Buzzer Software Schematic

5.5. System Schematics

Inside the SPL LL_85 laser diode

As its internal figure depicts, our OSRAM SPL LL_85 pulsed laser diode consists of two driver stage capacitors each having 47 nF as well as an Infineon BSP318S MOSFET with a 300 pF gate capacitance. These 47 nF capacitors by necessity are first charged (with a DC voltage) and then discharged after triggering the MOSFET's gate. Of course, the laser chip should facilitate this discharge following the MOSFET's triggering and a high-amp current pulse will ensue which allows for high peak power emission (16W maximum peak power for our laser). This high-amp (around 1A) current source is used to overcome the gate's 5V threshold voltage and by necessity should be a pulsed trigger current.

After all, because this source is limited by a 0.1% duty cycle, attempting to apply a constant direct current would result in heat buildup in the packaging overall. This buildup of heat can permanently damage the device, decreasing performance in output optical power and potentially harming other functionalities [39].

Conveniently, a certain high-speed MOSFET driver is capable of delivering the desired high-amp current signal. This current signal could be driven by using a transistor-transistor logic (TTL) level voltage [39]. TTL is thus deemed by having transistors for logic and amplification, but the terminology here is used to specify a compatible logic level as an input to the MOSFET driver rather than any specific integrated circuit component [39], [24], [65].

The figure below (Figure 5.5-1.) depicts the SPL LL85 laser with pins numbered to facilitate ease of description. The numbers immediately below describe the pin functions and are numbered correspondingly.

1. The first pin will carry the high-amp current trigger to the MOSFET's gate.
2. The second pin is used to charge the parallel 47 nF capacitors.
3. The third pin serves as the ground.



Figure 5.5-1 – SPL LL85 Laser Diode

Reasons for choosing our pulsed laser diode:

When cost is of concern as it is in our group the need for cheaper yet reliable alternatives greatly increases. This pulsed laser diode seems to be a great choice when comparing prices of other lasers with similar characteristics that operate at or near 850nm. A company called QPHOTONICS lists a single mode FP laser that offers pulsed operation that sells for \$340.00, which is more than fifteen times the cost of our laser [55].

Although the fact that prior implementation into laser ranging devices does not dictate that this laser is the greatest device on the market for that purpose but it does say something towards the possible effectiveness [39]. After all, many

people find relief and reassurance in reminding themselves when something has been done before. It seems like the right move overall to order a part that's been tried and tested.

This laser comes well equipped with implemented circuitry. This circuitry allows the laser generate high-speed pulses and will be further detailed in another portion of this document.

The quantum well structure of this laser is designed in such a way to minimize radiation leakage and to provide Optimum Optical confinement. In addition, this laser offers a low threshold emission based on its structure. The overall implications of structure are further discussed in the quantum well device section of this document.

Our source lens

Below (Figure 5.5-2) is a design of our lens using the Zemax optics studio optical design platform. The lens is shown in a way to simulate the effect of sending in relatively monochromatic light. This lens modeling provides useful insight into the behavior of the lens in our overall system. We selected the N-BK7 bi-convex lens from Newport with a 12.7mm diameter and a 38.1mm effective focal length [42].

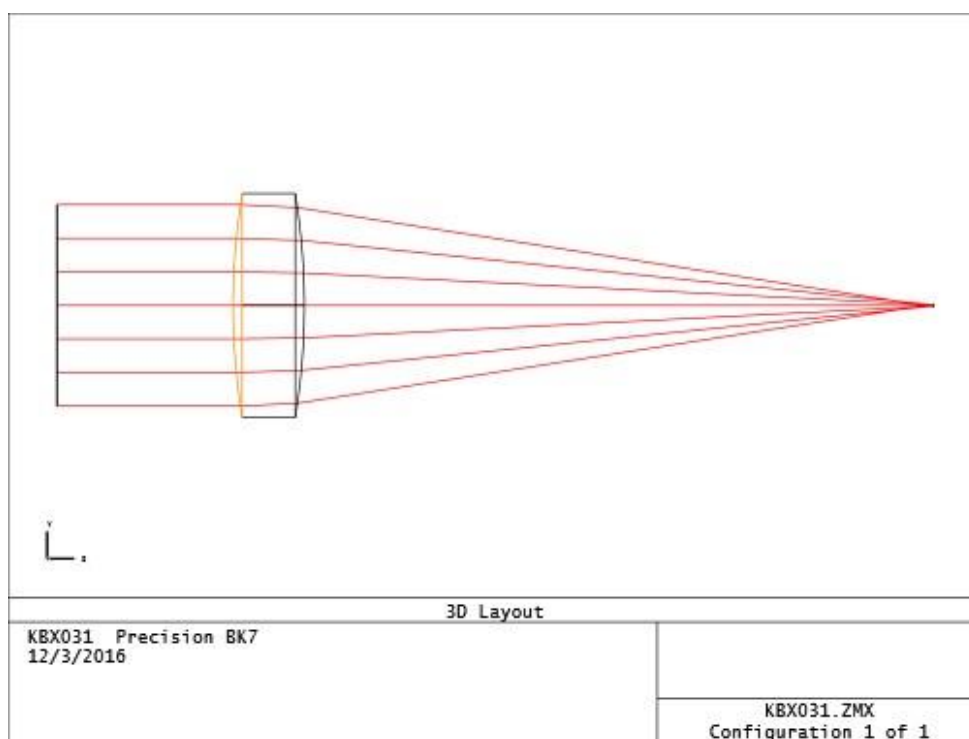

Figure 5.5-2 – Lens Diagram using Zemax Optics Studio (permission not needed)

The following figure is a 3-dimensional polychromatic Fast Fourier Transform (FFT) point spread function of our source lens. This simulation helps us to know more about what light might do when it propagates through our lens.

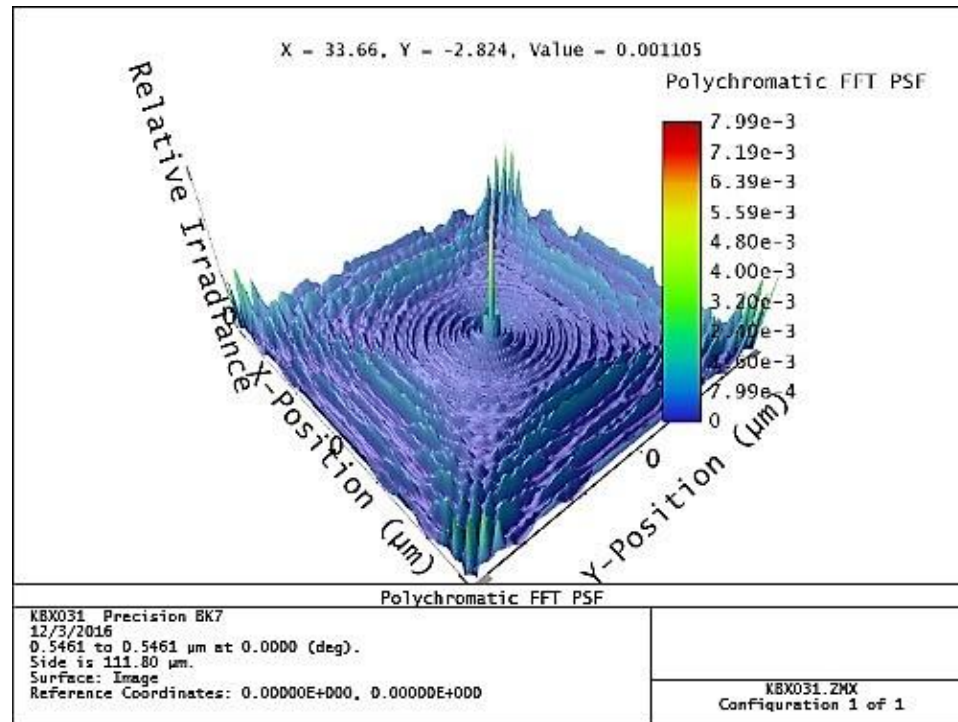

Figure 5.5-3 – 3D FFT Point Spread of Source Lens (permission not needed)

Detector Optical Design

In optics design it is important to consider all constraints in a given system. In this case, there are a couple of concerns that arise on the receiver end due to the nature of the project's design and implementation. The first and main concern is the angle of the light incident on the detector lens. If the light comes in at too great of an angle off of the optical axis relative to the lens and detector then the light could miss the detector completely due to the nature of the lens. This is why it is important to consider the active area of the detector and the angle of the incoming light. This can be easily compensated for by placing the transmitter and detector at an angle however this would limit the system to a certain range of operation. Since the project has a specified range the angle can be easily determined.

Assuming imperfect alignment of the transmitter and the detector, the input angle dilemma can also be further reduced by using a lens that is somewhat strong, in that it focuses the light at a short distance from its vertex. A lens with a short focal length will allow light from greater angles to still hit the detector. This can be seen in the comparison of two lenses of the same physical diameter, but different effective focal lengths. A comparison was made using Zemax Optics

Studio 2015 software to help design the optical system of the detector. Two lenses from Newport, KBX019 and KBX013, were used to help define the design using lens that is reasonably priced and somewhat practical as shown below in Figure 5.5-4.

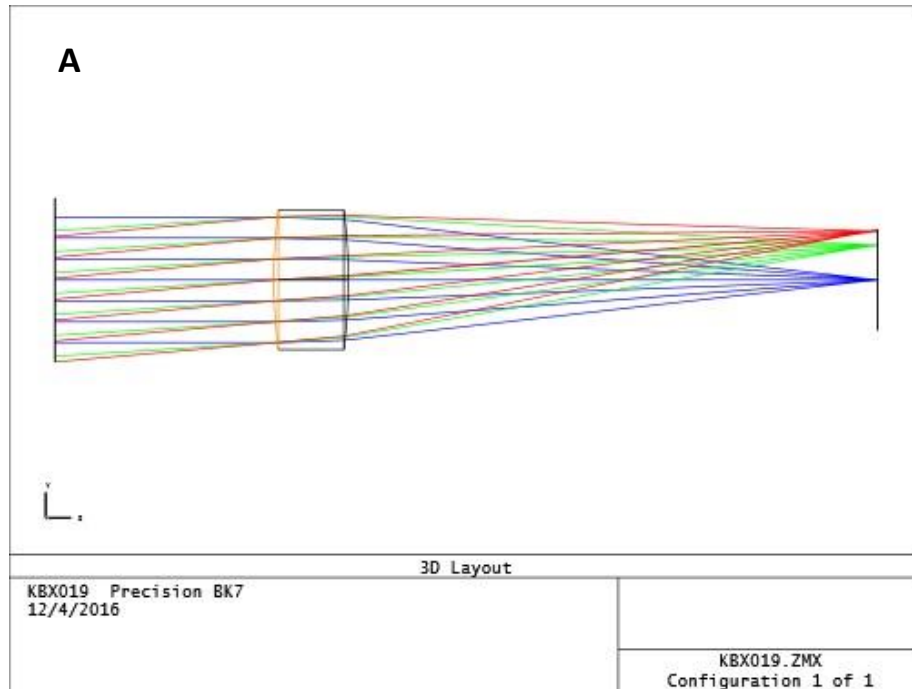

Figure 5.5-4a – Newport KBX019

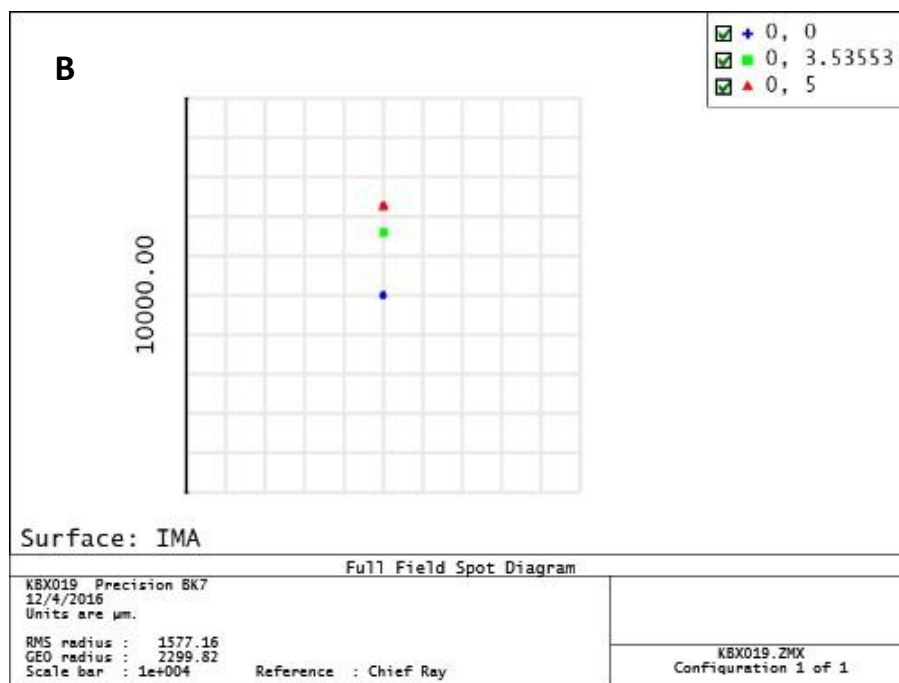

Figure 5.5-4b – Newport KBX019

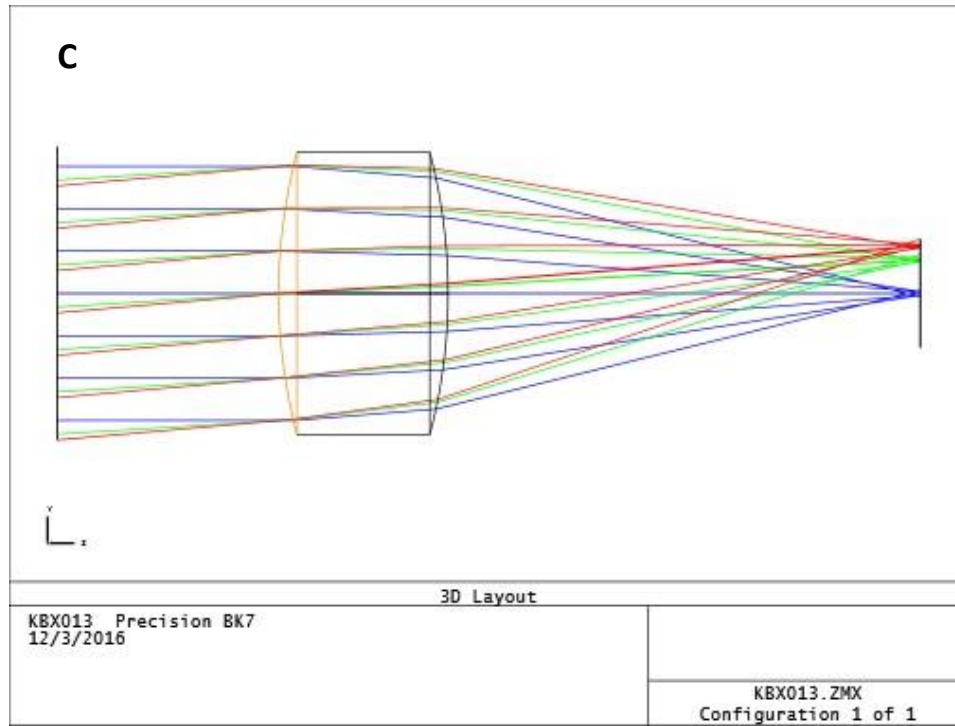

Figure 5.5-5a – Newport KBX013

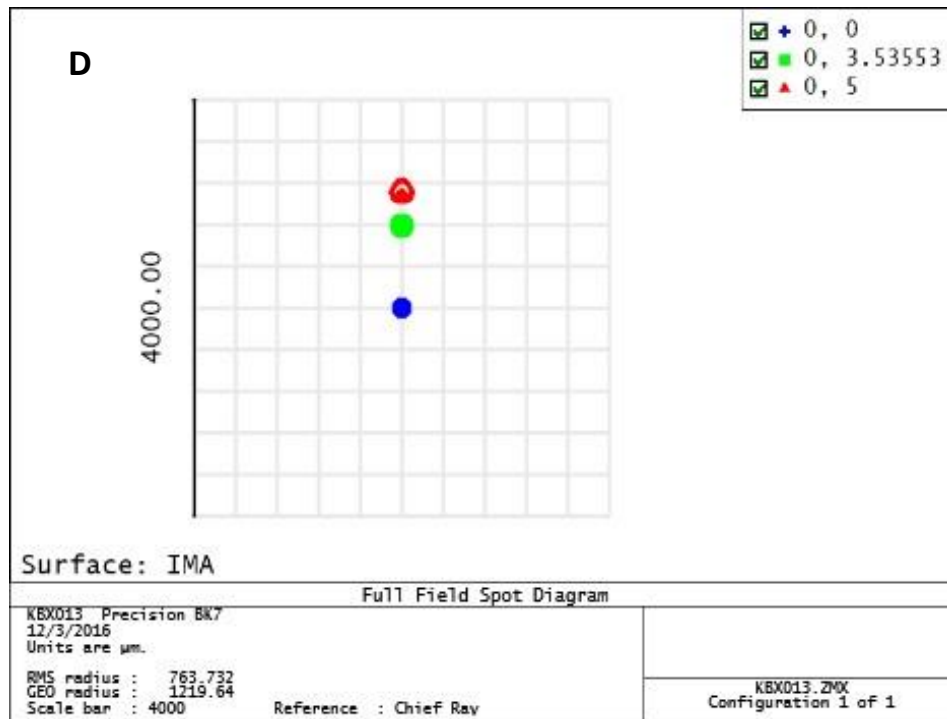

Figure 5.5-5b – Newport KBX013

For lens KBX019, the above (Fig 5.5-5) are plots of the A) 2D ray trace at 0, 3.53553 and 5 degree input angles into the lens, and B) the optimal overall spot size diagram of the lens at the given angles. For lens KBX013 the above are plots of the C) 2D ray trace at 0, 3.53553 and 5 degree input angles into the lens, and D) the optimal overall spot size diagram of the lens at the given angles.

For KBX019, the effective focal length is approximately 25.4mm. As shown above, the full field spot for 0, 3.53553, and 5 degree off axis field angles has a geometric radius of about 2.2 mm. This means that the light entering into the lens at some angle between 0 and 5 degrees can hit up to 2.2mm away from the center of the detector. For KBX013, the effective focal length is approximately 12.7mm. As shown above, the full field spot for the same off axis field angles has a geometric radius of about 1.2 mm. This means that the light entering into the lens at some angle between 0 and 5 degrees can hit up to 1.2mm away from the center of the detector. Therefore, if the off angle fields fall out of range of the detectors active area for a lens with a given focal length, a lens with a shorter focal length can better fit this system's needs.

As mentioned before there arises a few concerns under the given conditions of this project with regards to the detection scheme. Aberrations can play a big role in any optical system, and in the case of this project we can look at the aberrations of a possible choice lens to get an idea of which ones could come into play. Below is a Seidel diagram and a spot diagram of the detector's optical system using the NBX013 showing the contributions of the aberrations at each surface and the sum of each, see Figure 5.5-6.

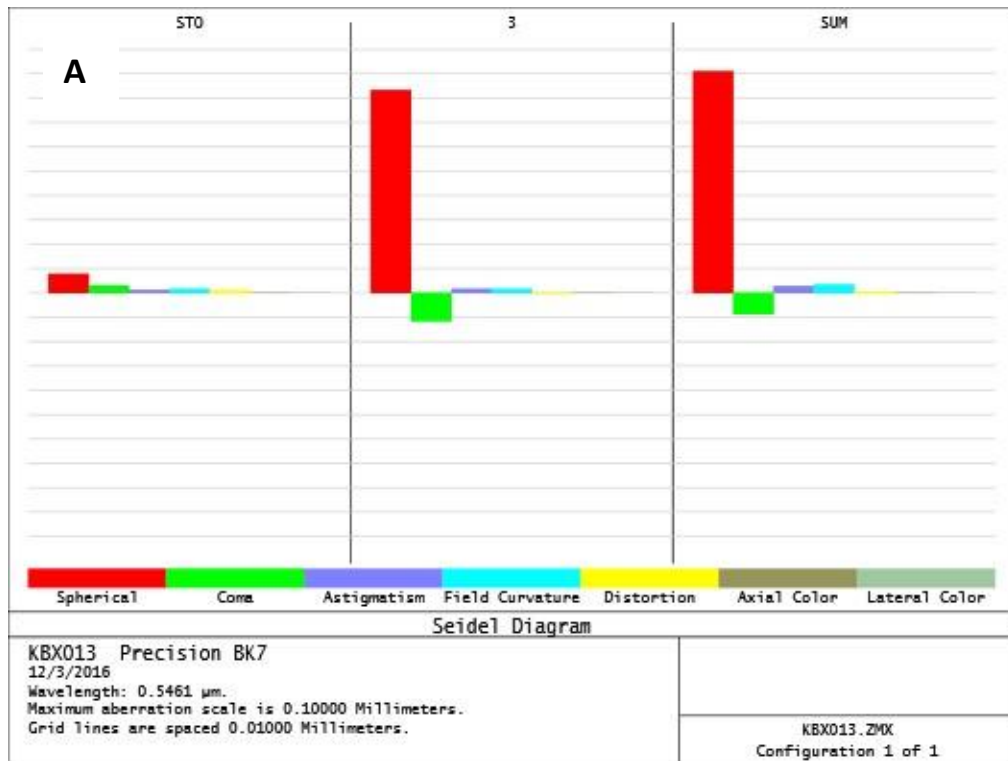

Figure 5.5-6a – Seidel Diagram for Optical System

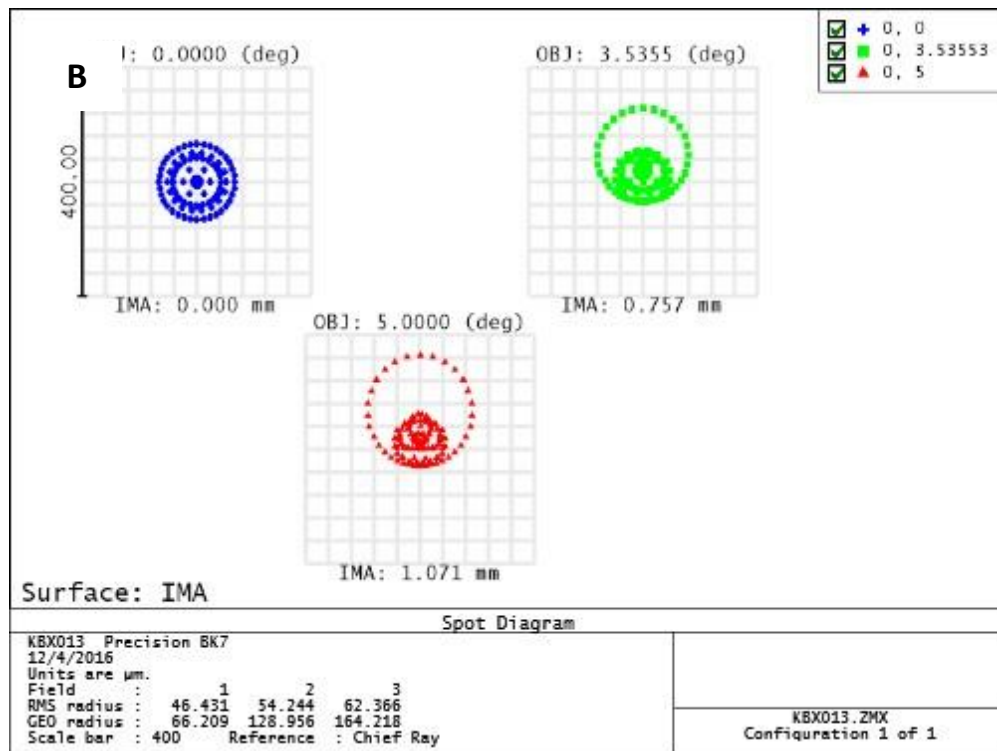

Figure 5.5-6b – Spot Diagram (for Optical System

Fig 5.5-6 A) Seidel diagram and B) the spot diagram of the optical system at object field angles of 0, 3.53553, and 5 degrees.

As seen in the Seidel diagram, there isn't much aberration in the system. The main contributor to aberration is clearly spherical. Looking at the spot diagram for each field angle, notice the RMS radius increase from 46um to 62um in only a 5 degrees field angle difference. This also should be considered in designing this optical system. The aberrations can also be seen and better assessed in the ray fan and optical path difference of the system. While important in most systems, chromatic aberration is of no concern here since the transmitter is coherent.

6.0. Build

With the design planned out and all our research completed, the next step is to build the prototype. Through the researching portion we have picked specific parts, chosen to give us the best result in our end product. Some key factors when choosing these parts was price, size, and functionality. Through the research process we have decided on which parts worked best for our project and are shown in the Summary of Parts section following this. A number will label each part, as some parts are too small to make out.

6.1. Bill of Materials

The following tables are a tentative representation of the materials required to build the project successfully. Changes in the number and value of components such as resistors and capacitors may be needed. For this reason, we have included extra parts just in case they should be needed.

TRANSMITTER		
<i>Item</i>	<i>Quantity</i>	<i>Description</i>
Laser Diode	1	SPL LL85
Plano-Convex Lens	1	
ADC	1	
Laser Driver	1	
1.0 Schottky Barrier Rectifier Diode	2	
Ferrite Bead	2	
Mosfet Driver	1	ELANTEC EI7104C
Mosfet Driver	1	UCC37322
39 ohm Resistor	1	.5 W
120 ohm Resistor	1	
200 ohm Resistor	1	
47 kohm Resistor	2	
1 kohm Resistor	1	
0.1 uF Capacitor	2	
10 uF Capacitor	1	
1 uF Capacitor	1	
4.7 uF Capacitor	1	
100 pF Capacitor	1	

Table 6.1-1 – Bill of Materials (Transmitter)

RECEIVER		
<i>Item</i>	<i>Quantity</i>	<i>Description</i>
Photodiode	1	SFH2701
Avalanche Photodiode	1	S2381
Plano-Convex Lens	1	
Op-Amp	1	OPA128 SM
Current-to-Voltage Converter (TIA)	1	
10 kohm Resistor	1	
220 ohm Resistor	1	
100 kohm Resistor	2	
1 kohm Resistor	1	
0.1 uF Capacitor	4	
10 uF Capacitor	1	
10 nF Capacitor	1	
1 nF Capacitor	4	
470 pF Capacitor	1	

Table 6.1-2 – Bill of Materials (Receiver)

TIMING		
<i>Item</i>	<i>Quantity</i>	<i>Description</i>
Time-to-Digital Converter	1	TDC 7200
100 nF Capacitor	1	
10 pF Capacitor	4	
1 uF Capacitor	4	
2 uF Capacitor	1	
0.1 uF Capacitor	1	
2.2 kohm	1	
100 Mohm resistor	1	
50 ohm Resistor	1	

Table 6.1-3 – Bill of Materials (Timing)

PROCESSING AND POWER MANAGEMENT		
<i>Item</i>	<i>Quantity</i>	<i>Description</i>
Microprocessor	1	TI MSP 430
Battery	1	9 V
1 kohm Resistor	1	
1.6 kohm Resistor	1	

Table 6.1-4 – Bill of Materials (Processing and Power Management)

HAPTIC FEEDBACK		
<i>Item</i>	<i>Quantity</i>	<i>Description</i>
Haptic Driver	1	drv2605
Diode	1	1N4001
NPN Transistor	1	2N2222
1 uF Capacitor	2	
0.1 uF Capacitor	2	
1 kohm Resistor	1	
2.2 kohm	1	

Table 6.1-5 - Bill of Materials (Haptic Feedback)

6.2. Summary of Parts

The picture below shows the parts purchased for our rangefinder. A fully detailed explanation as to why one part was chosen over another is below the picture. Smaller components such as resistors and capacitors are not shown in this. We were not sponsored with any money, so cost and functionality was the defining decisions for each part. Some of the parts we were lucky enough to get for free, thanks to companies like Texas Instruments.

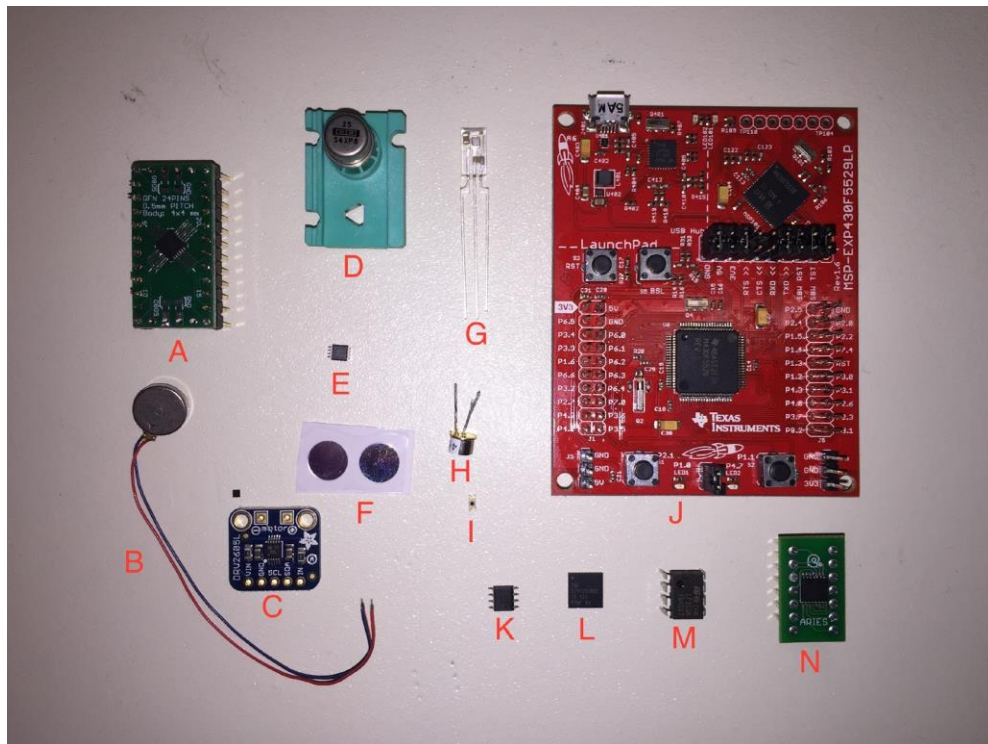

Figure 6.2 – Summary of Parts

A. Laser Driver

The ONET1151L is a low power (3.3V) laser diode driver that offers high modulation data rates, a simple serial interface (2-wire) paving the way for digital interface with the bias current and overall modulation. It has a built-in Automatic Power Control loop that aids in creating a safer environment for the circuitry overall. Also, its digitally selectable biasing current is a great plus for certain applications.

B. ERM Coin Vibration Motor

The eccentric rotating mass coin vibration motor was the best fit for our design. The other choice of using a linear resonant actuator vibration motor was also considered and it is very similar in size, but in the end we picked the ERM pancake model. The other type of ERM to choose from is the 'Pager' style. This 'Pager' motor is bigger than the 'pancake' motor, and because of that we didn't feel it was the best pick for our project. The vibrating motor in our project needs to be smaller because it will help keep the overall size of our rangefinder down.

C. DRV2605 Haptic Driver for ERM and LRA

The DRV2605 can give us more options of vibrations for our haptic feedback. It can also help with prototyping in comparison with just running the haptic feedback through the msp430 microcontroller. As with our other TI obtained parts, the price made the DRV2605 a good choice as well.

D. OPA128SM Operational Amplifier

The OPA128SM operational amplifier is a low noise op-amp that boasts an ultra-low bias current. Because of this, one of the applications it is good for is in photodetection.

E. OPA381 Transimpedance Amplifier

The features of the OPA381 transimpedance amplifier make it a good choice for precision current-to-voltage conversion. It has a higher max input biasing current than the OPA128 at 50 pA with a typical output current of 10 mA.

F. 850 nm Narrow Bandpass Filters

These filters have the following specifications:

- 8.0mm in diameter
- Thickness of 0.55mm
- Center wavelength is 850nm+/-5nm
- Half-band width is 30nm
- Peak transmissivity is >86%
- Cut-off percentage is <1%
- Mirror-glass material

G. SPL LL85 Laser Diode

We have chosen this laser diode due to the following reasons:

- It is relatively low cost compared to other pulsed laser diodes and near IR range

- It has been used previously in ranging applications
- It comes standard with built-in circuitry
- It can deliver high-speed post light in the nanosecond range
- It takes advantage of Quantum well structure that is capable of delivery narrow line with emission and requires less current than certain bulk semiconductors in order to achieve light emission

H. S2381 Avalanche Photodiode

The primary candidate photodetector is the S2381 avalanche photodiode (fig. [?]). Its low active area is beneficial, as it has the lowest amount of dark current in comparison to the others in its family with a rating of .05 nA. This particular model of photodiode is discontinued, and a model of comparable specifications is relatively expensive. For this reason, we have chosen to have a supplemental candidate; the SFH 2701 PIN photodiode.

I. SFH 2701 PIN Photodiode

The SFH 2701 (fig. [?]) is a very inexpensive Si PIN photodiode with a fast switching time and ultra short decay time. Its spectral range is from 400 nm to 1050 with a peak wavelength of 820 nm. Its rise and fall times are both 2 ns. A comparison of the parameters of the SFH 2701 PIN photodiode and the S2381 APD is shown in the following tables:

SFH 2701	VALUE
Effective Active Area (mm ²)	0.36
Min Operating Temperature (°C)	-40
Max Operating Temperature (°C)	85
Min Spectral Response (nm)	400
Max Spectral Response (nm)	1050
Peak Sensitivity Wavelength (nm)	820
Photosensitivity at 780 nm (A/W)	0.5
Typical Dark Current (nA)	0.5
Capacitance (pF)	3

Table 6.2-1 SFH 2701 Parameters

S2381 APD	VALUE
Effective Active Area (mm ²)	0.3
Min Operating Temperature (°C)	-20
Max Operating Temperature (°C)	85
Min Spectral Response (nm)	400
Max Spectral Response (nm)	1000
Peak Sensitivity Wavelength (nm)	800
Photosensitivity at 800 nm (A/W)	0.5
Quantum Efficiency at 800 nm (%)	75
Typical Breakdown Voltage (V)	150
Max Breakdown Voltage (V)	200
Typical Dark Current (nA)	0.05
Max Dark Current (nA)	0.5
Cutoff frequency (MHz)	1000
Terminal Capacitance (pF)	1.5
Gain at 800 nm (M)	100

Table 6.2-2 – S2381 APD Parameters

J. MSP430F5529 Launchpad

The MSP430F5529 is shown to be a better candidate than the others being considered primarily due to the addition ports and higher processing power. It will be a significant need for the number of components the MCU will be responsible for controlling.

K. THS4031CD Amplifier

The THS4031 high-speed amplifier has a 100 MHz bandwidth with a typical gain bandwidth product (GBW) of 200 MHz. It has very low distortion and ultra-low voltage noise. This amplifier is a candidate for voltage amplification after the photocurrent conversion in the receiver.

L. TRF371125 Wide Bandwidth Integrated Direct Down Conversion Receiver

When working with lidar for our rangefinder we knew we needed something to implement the down conversion. The TRF371125 from TI was the choice we made. We were able to obtain a free part, which combined with Texas Instrument's reputation for quality parts, is why we picked the TRF371125 for our down conversion

M. LF351 Op Amp

The LF351 op-amp has a low input bias current of 50 pA and high input impedance. It has a wide gain bandwidth of 4 MHz with low input current and voltage noise. This op-amp may be suitable for secondary amplification in the receiver once the photocurrent is converted into voltage although the THS4031 may be a better candidate.

N. TDC7200 Time-To-Digital Converter

The TDC7200 has been decided over the TDC7201. The main reason we chose the TDC7200 is the pin package. We are able to test and implement the TDC7200 much easier into our system with the TSSOP (14) package. There wasn't much of a tradeoff in performance for this decision. Both parts can accomplish the time-to-digital conversion for a lidar system. They power consumption and range features for each part both worked with our project. The prices for both were also the same.

7.0 Prototype Testing

In the following section we will discuss the procedures for testing the components of navigation system. Since the testing environment is crucial for the success of the project, we will begin with its details. Following the discussion of the testing environment, we will go over testing the individual parts of both the hardware and the software. Ensuring the individual components work will be the first step into actually integrating all parts of the project.

7.1. Testing Environment

There are several areas at UCF available to use as testing areas. These consist of the Smart Lab in the Harris Engineering building, the senior design lab in the Engineering 1 building, the UCF Innovation lab in the Engineering 2 building, and the senior design lab in CREOL. Most of our work will be done in the CREOL lab since there is much less traffic in terms of students using the space, and most of the equipment needed to test and put together the project will be provided by UCF.

UCF Provided Equipment:

- Tektronix Dual Channel Function Generator
- Tektronix Digital Precision Multimeter
- Agilent Triple Output DC Power Supply
- 3D Printers
- Agilent Optical Spectrum Analyzer
- Laser Safety Glasses

UCF Provided Software:

- Multisim
- Matlab
- Zemax

Team member supplied equipment

- Soldering Helping hands with LED and magnification lens
- Breadboards
- 3.3 V – 5 V Power Supply

7.2. Safety Procedures

Laser Safety

The most effective method to manage the risk associated with laser radiation exposure is to put safety first. By developing an effective safety plan, the risk of laser accidents can be minimized. The laser safety plan should include Safety Procedures, alignment procedure, environmental controls, protective equipment, personnel training and operational controls.

Safety Procedures

One of the most important administrative controls, as part of the safety plan, is developing safety procedures. To develop effective safety procedures, start by identifying the risks associated with lasers or working around laser that could result in unwanted laser exposure. Since each application is unique, the manufactures instruction for safe operations may not be perfectly suited for each situation. Therefore, it is paramount to involve individuals that operate, maintain and service the laser equipment and setup in identifying the risks to develop and maintain a safe laser environment.

Alignment Procedures

Since many laser accident occur during laser setup and alignment, it is very important to place adequate precautions in the operating instructions/procedure. The instructions should be written as a Standard Operating Procedures (SOP) to avoid variations as well as misinterpretations in instruction when dealing with repetitive tasks.

Personnel Access Control

Unless identified a necessary observer, all personnel not directly involved with the laser setup or operations should be kept away from a hazardous laser environment. In the case of operating with a Class IIIB or Class IV laser, proper protective equipment should be used by everyone that enters the environment.

Protective Equipment

Proper Personnel Protective Equipment (PPE) should be used to prevent hazardous exposure to laser radiation. PPE such as goggles, clothing, gloves and other barriers are available for individual protection.

1. Eye Protection

Eye damage due to laser radiation exposure is by far the most common reported injury when working with or in a laser environment. Injury due eye

exposure to laser radiation can be mitigated by the use of protective eyewear, which can be in the form of goggles or spectacles. In addition to administrative or operational controls, eye-protection devices that are designed to protect against hazardous exposure to laser radiation should be used regardless of the level or time of exposure, which usually applies to Class IIIB and Class IV lasers. Since not all laser eye-protection devices are created equally, they should be selected and labeled according to the wavelengths that they are designed to block/protect against. When selecting eyewear, several important factors need to be considered such as: wavelength, optical density, beam power, type of laser, power mode, strength and design.

2. Skin Protection

Very similar to eye injury, skin can be damaged when exposed to hazardous laser radiation. Skin protection from ultraviolet lasers can be in the form of clothing, gloves or skin creams (i.e. sun-screen). Gloves that are opaque or made of tightly woven material and standard lab coats provide protection from laser radiation for your hands and arms respectively.

Training

All personnel that work with lasers need to be properly trained and qualified, particularly when operating Class 3 or Class 4 lasers. To be qualified, the on-the-job training should include laser familiarization, equipment familiarization, safety plan and procedure familiarization, control procedures, personnel protective equipment familiarization. All qualified operators must be able to identify the hazards and controls necessary to mitigate the risk associated with laser radiation exposure. In addition, all personnel should be required to take courses in Cardiopulmonary resuscitation (CPR) as well as electrocution rescue.

7.3. Hardware Testing

Testing TRF371125 Direct Down Conversion Receiver:

To test the TRF371125 down converter there are a few different routes to take. We obtained a breakout board for the package group VQFN. Setting up the part on the breakout board allows for a simple testing environment. Connecting the board to the msp430 will then allow us to test the part to make sure it works.

Requirements:

- TRF371125
- VQFN (48) breakout board
- Breadboard
- Msp430 Launchpad
- Power Supply
- Soldering Station Kit
- Digital Multimeter

Our other option is to use Texas Instruments evaluation module. For \$299.00, the TRF371125EVM is used to evaluate the direct quadrature demodulator device. The TRF371125EVM uses a radio frequency balun as a differential signal to receive the radio frequency input and local oscillator input. This balun can be adjusted to enable operation in the frequency band of interest. It is first injected into the RFin connector, which is then delivered into the TRF371125 input ports. The local oscillator source, connected to the LO (local oscillator) pins, using another balun is injected into the LO pins of the TRF371125. After this the signal can be down converted and filtered to be tested at the baseband output.

Testing TDC7200:

The TDC7200 Time-To-Digital Converter has a package group of TSSOP. With a breakout board created for a part with package group TSSOP, and using the msp430, we are able to test the TDC7200.

Requirements:

- TDC7200
- TSSOP (14) breakout board
- Breadboard
- Msp430 Launchpad
- Power Supply
- Soldering Station Kit
- Digital Multimeter

If we are looking to take another route for testing the TDC7200EVM, available from Texas Instruments, is another tool that can be used to test the TDC7200. The TI website lists the TDC7200EVM for \$75.00. It comes in a package capable of connecting with the MSP430 launch pad as well. Some key features for why this route is better are a friendly GUI interface and connection for START and STOP inputs. The GUI helps users modify registers and display data. The START and STOP pulses have two SMA connectors. This evaluator might be worth the money for some cases, because it provides a platform to make it easier for testing and designing with the TDC7200.



Figure 7.3-1 – TDC 7200 EVM Hardware (permission requested)

Testing drv2605:

The drv2605 haptic driver can be tested on a breakout board for package DSBGA(9). Using an msp430 microcontroller the driver can be tested for its different feedback options.

Requirements:

- DRV2605
- DSBGA (9) breakout board
- Breadboard
- Msp430 Launchpad
- Power Supply
- Soldering Station Kit
- Digital Multimeter

Another option is with a pre-mounted drv2605 version through the company Adafruit. With just the power supply, breadboard, and Digital Multimeter testing for various vibrations is very easy right out of the package. It comes with the drv2605 already on a breakout board and long pins to make the set up on a breadboard very easy to solder. There are pins already set up for Vin, GND, SCL, SDA, and IN/TRIG. When testing on the drv2605, the voltage should be set between 3 and 5V. There is a 10K pullup on the SCL pin, which is a 12C clock pin connecting to the microcontrollers 12C clock line. The SDA, likewise, has the same 10K pullup, connecting the 12C data pin to the 12C data line of the microcontroller. The IN/TRIG pin can be used for general-purpose use. It can be used to read the analog audio, or it can be used as a trigger for the effects rather than the 12C command.

For \$99.00, Texas Instruments offers an evaluation board that can be chosen as a third option for testing the part. The DRV2605EVM-CT, comes with a microcontroller and can work for both Linear Resonant Actuators (LRA) or Eccentric Rotating Mass (ERM) motors. This board contains capacitive touch buttons and sample waveforms to give a broader testing channel. Some other features include 123 effect haptic waveform library, 12C digital playback engine, and automatic calibration.



Figure 7.3-2 DRV2605EVM-CT Hardware (permission requested)

Testing the Haptic motor:

To test the vibrating motor we need our coin ERM motor and the msp430 microcontroller.

Requirements:

- Coin Mobile Phone Vibration Motor
- Msp430 Launchpad
- Power Supply

Testing the motor gives us an idea if one motor will be enough for our final project design. The motor was loud and gave decent vibration with 3V applied to it. The msp430 Launchpad can delay the vibration giving us an effect that works for our project. If the power disbursement becomes a problem, we might take this route over using the drv2605. Adding a transistor to the circuit can also make up for lack of high current amount coming from the microcontroller.

Implementing a more realistic test for the buzzers is a simple matter of simulating an environment similar to that of the one that will be present within the final testing phase of the project. Since the time between the current testing phase

and the testing phase upon the integration of all components is not sooner, a visual test will be demonstrated on the MSP430 evaluation board for proof of functionality. Due to the inability to see a working buzzer on paper, I have decided to instead to represent the cases where the buzzer would normally be with LED's. This will provide a visual representation for the proof of functionality. Also, there is not a way to accurately test for the processing of the data. For this, I've used one of the available timers on the MSP430 to simulate that case. In the code, I've set up a function that will send a signal to the port that turns on the red LED for the far case. The timer, `TIMER_A` was used as a counter that causes the red LED to emit and stay on. In the actual software implementation, as well as in further tests, the LED will turn off after a certain distance.

This will be tested in the case following the integration of the laser and supporting components. In the meantime, the above method will be utilized to obtain a close representation of the actual system. This will be the case in which an object will be detected, but of far distance, which will cause the buzzer to begin buzzing, but at a low frequency. The figure below shows the result of the far case. Note that the connection used for powering the microcontroller is the battery holder mentioned before. Since the final product will be tested without using power from the computer, it would be useful to test this feature using one of the proposed powering methods.

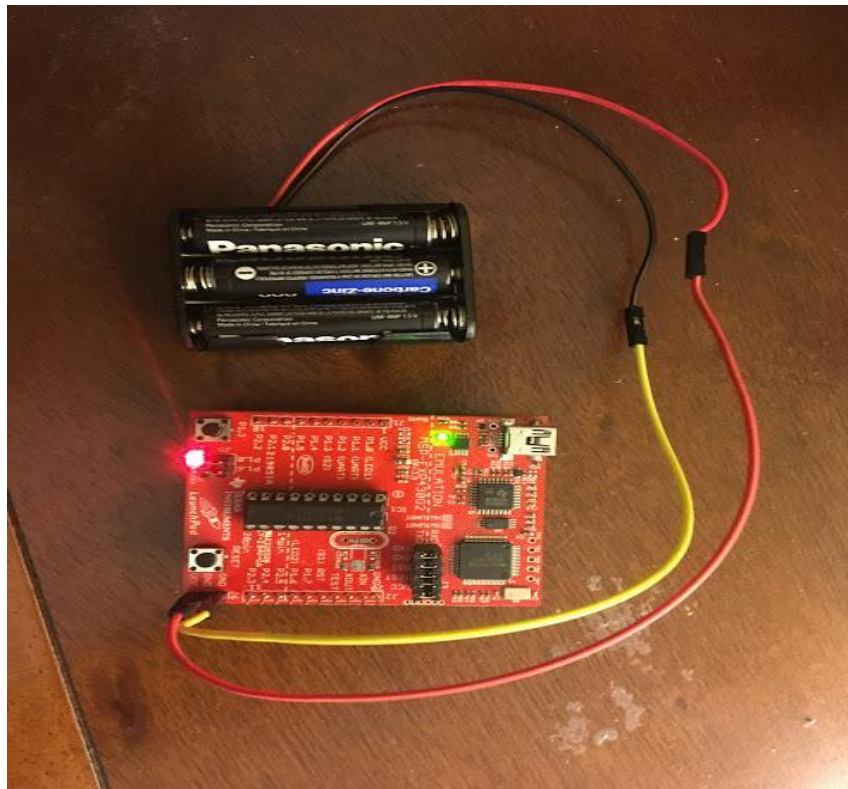

Figure 7.3-3 – Test Case Result for Long Distance

The second case to be tested is the test for the medium distance. This will be the case for when an object is within close range to the user, but is not close enough to need to immediately take action to avoid the object. As similar to the first case, there is a limitation to implementing this step, as the integration process has yet to begin. Once this process has begun, the code will be modified to suit the more realistic implementation.

For the implementation, `TIMER_A` was once again used as the deciding factor on when to turn on the LED. The amount of time was modified to simulate a scenario for when an object may be in a medium distance from the user of the product. Once the timer has run all the way thru (simulating the amount of time it would take for the signal from the transmitter to return to the receiving unit and process before reaching the input signal on the microcontroller), the green LED will turn on for a period of time.

The figure below shows the green LED turning on as a result of the timer running out for the case of the medium distance. It should be noted that the transition between the red LED turning on to the green LED doing so was controlled by a press of the push button. This was done so that images could be obtained without the LED switching before wanting it to do so. The code is set up to switch the duration of the timer for each press of the button to represent each of the three cases. In the implementation of the actual project, these LED's will not be controlled using the LED's. As a matter of fact, the switch will be used as an on-off switch that will enable the user to determine when they want the device to operate.

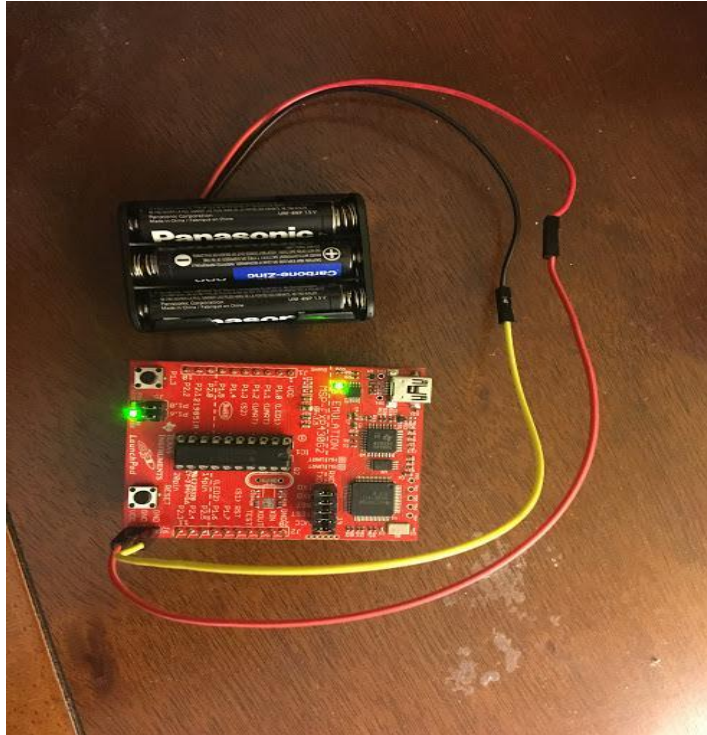

Figure 7.3-4 – Test Case Result for Medium Distance

The third test that's run is for that of the close distance case. This will be the case for when the detected object is of range where the user will know that the object is close enough to where they need to consider an option for maneuvering around the object. Once again, one should take into consideration that because the integration step has not been implemented, alternative methods were taken to test the functionality of the code.

This case was unique in that it did not have a third LED to test out. This was not a difficult task to overcome, as the solution would be to simply turn on both LED's for this case. The timer, `TIMER_A` was used for this case as well. The amount of time that the timer will run for is shortened in order to simulate a closer distance than that of the previous one given. This is done so to simulate the shortened time between the rangefinder detecting an object and receiving and processing of the information in the MCU. The figure below shows the result of the timer running out for the case of the closer distance.

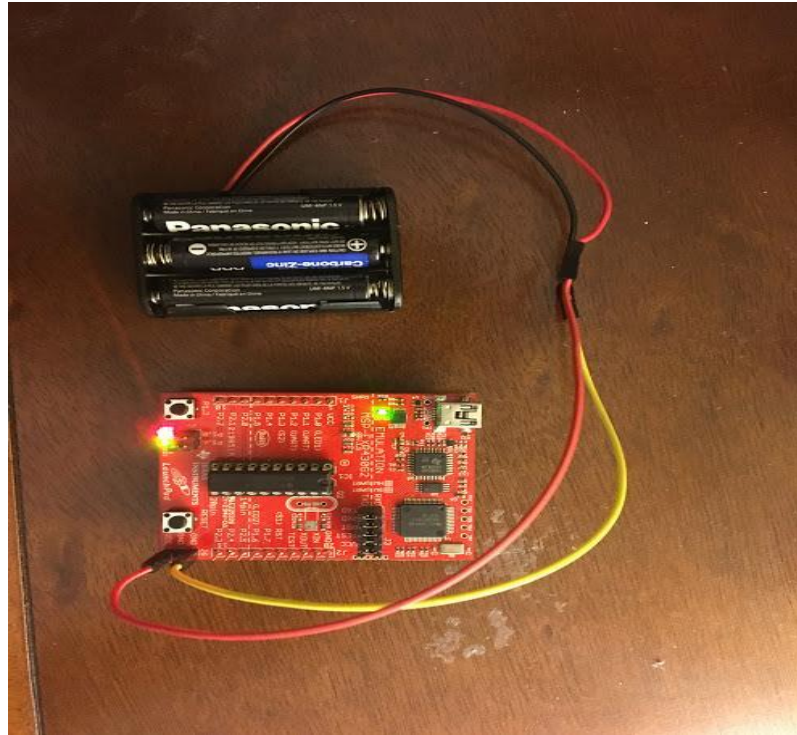

Figure 7.3-5 – Test Case Result for Short Distance

The testing for the three cases were shown to be successful. Some modifications will be made to the code in order for the code to be able to function for what we want to implement. It is hopeful that using the interrupt method will show to be possible for this step in the design. Being able to do so will help reduce the battery drain rate, which will allow for the user to operate the design for a long period of time. We believe that this could be implemented by either creating a timestamp of two iterations of receiving the signal and using subtraction in order to determine the relative distance. Once that relative distance is calculated, the microcontroller will be able to determine the distance. If no such way is possible, the backup plan will be to implement the polling method instead. Although, using this method will cause a faster drainage in the battery. It is believed that for demonstration purposes, it will not cause a drain in the battery that is so significant that it will not allow time for the entire device to function that given timeframe.

Photodiode testing

The objective of testing the photodiode is to ensure that it operates correctly in forward bias and reverse bias mode. Successful testing of the photodiode will allow interaction between it, the transimpedance amplifier, and the operational amplifier. The devices need to test the photodiode are:

1. Digital Multimeter (DMM)

2. Si Photodiode
3. Banana cables
4. Alligator Clips
5. Light Source

The digital mutimeter used in the lab has a feature specifically used for testing diodes. The steps for testing are as follows:

1. For Photovoltaic Mode (figure 7.3-6 (left)):
 - a. Connect banana cables to DMM
 - b. Attach alligator clips to the end of the banana clips
 - c. Turn on DMM and set it to the diode test
 - d. Connect the red alligator clip to the anode of the photodiode
 - e. Connect the black alligator clip to the cathode of the photodiode
2. For Photoconductive mode (fig 7.3-6 (right)):
 - a. Connect banana cables to DMM
 - b. Attach alligator clips to the end of the banana clips
 - c. Turn on DMM and set it to the diode test
 - d. Connect the red alligator clip to the cathode of the photodiode
 - e. Connect the black alligator clip to the anode of the photodiode

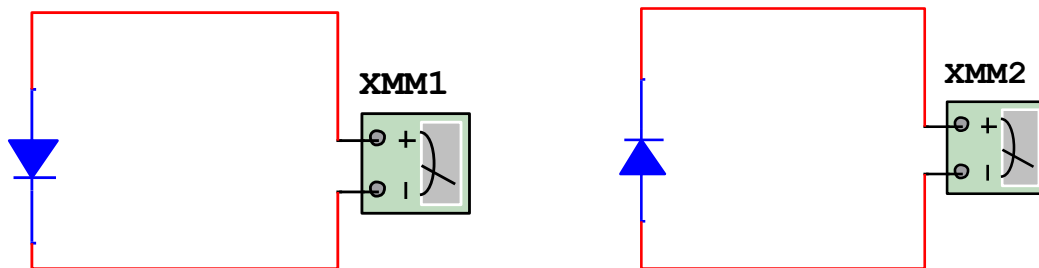

Figure 7.3-6 – Test Procedure for Photovoltaic Mode (left) and Photoconductive Mode (right)
 The results for a successful test will be different for the photovoltaic and photoconductive modes. For photovoltaic mode, we should see a voltage between .5 V and .7 V. In this case, the voltage measured was .6854 V. For photoconductive mode, we would expect to see an open circuit. The DMM did, in fact, read OPEN suggesting the photodiode is in good working order.

Operational Amplifier testing

Op-Amp as a current-to-voltage converter:

Unfortunately due to its high level of performance, the OPA 128 operational amplifier is extremely difficult to test. To test and see if the current-to-voltage circuit shown in (fig ?) works, an LF351 operational amplifier will be used in its place. The circuit will serve as a test for the duties of a transimpedance amplifier

and for the functionality of the op-amp itself. The required components for successful testing are as follows:

1. 22 M Ω Resistor (8)
2. 22 k Ω Resistor
3. 2 k Ω Resistor
4. OPA 128 Op-Amp
5. SH 702 Photodiode

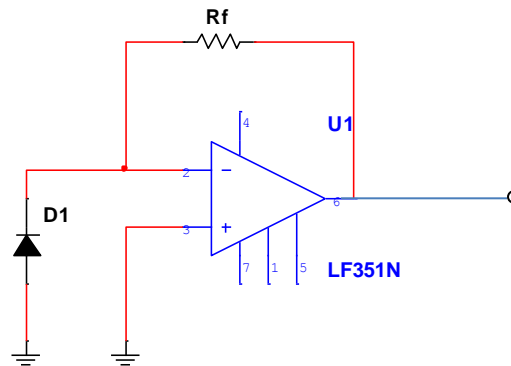

Figure 7.3-7 – Operational Amplifier Testing Schematic

The procedure for testing the op-amp is quite simple and is as follows:

1. Connect the resistors in series to work as a feedback resistor
2. Connect the reverse-biased photodiode to pin 2 of the op-amp and ground it
3. Ground pin 3
4. Connect the feedback resistor to pin 2 and pin 6

Pins 1, 4, 5, 7, and 8 will not be used in this configuration

Testing the pulsed laser diode

The figure (Figure 7.3-8) below is a schematic proposed for testing the SPL LL85 strained InAlGaAs/GaAs QW laser. The manufacturer integrates components to the right of the charging resistor in the laser's small sized plastic head package: two parallel 47uF charge capacitors, an NMOSFET (Infineon BSP318S), and a laser chip. The 47uF capacitors are used to store charge (charged supplied via the charge voltage (V_c) in series with the charge resistor). The charge resistor should be selected such that the charge capacitors will be charged at a very fast rate to not limit the lasing rep rate. For this purpose, we have selected a low ohm (39Ω) resistor that can handle around 1/2 Watts of power [39].

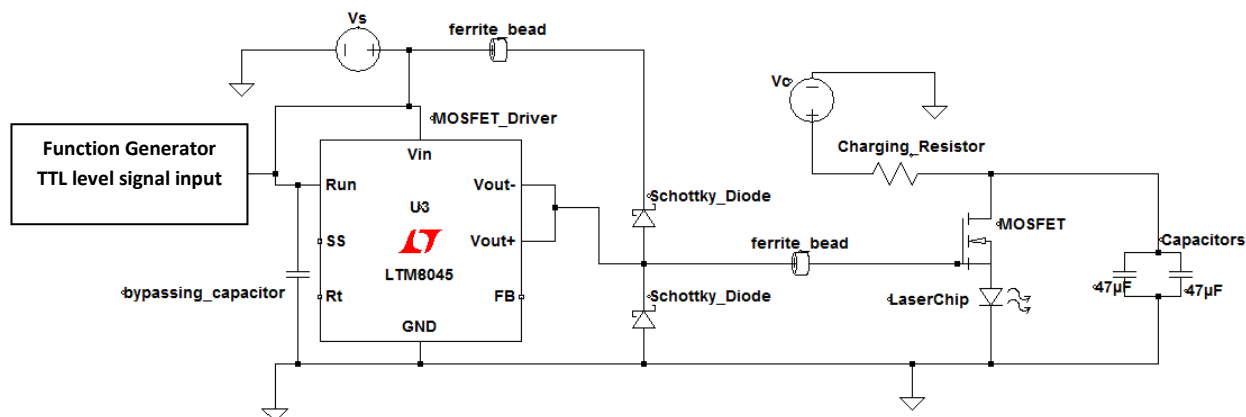

Figure 7.3-8 – SPL LL85 Testing Schematic (permission not needed)

The Following figure (Figure 7.3-9) is a simplified layout of the setup for testing the output optical power of our device. In the more simplified continuous wave (cw) laser case, we could just connect our laser to a tunable laser current driver and measure (with an optical power meter) the output optical power versus input current. Unfortunately, this method for laser analysis will not suffice in our case in which cw operation would result in the device's degradation [39]. Instead, we use an external driver with additional circuitry that is fed with a TTL level signal (as previously noted). This voltage signal triggers the driver which in turn sends a high current (around 1 amp) to trigger the internal MOSFET's gate. Once the gate threshold is overcome, the parallel capacitors in the head will discharge into the diode creating a high energy pulsed output. These charge capacitors are fed by a charge source (V_c) that can be adjusted accordingly.

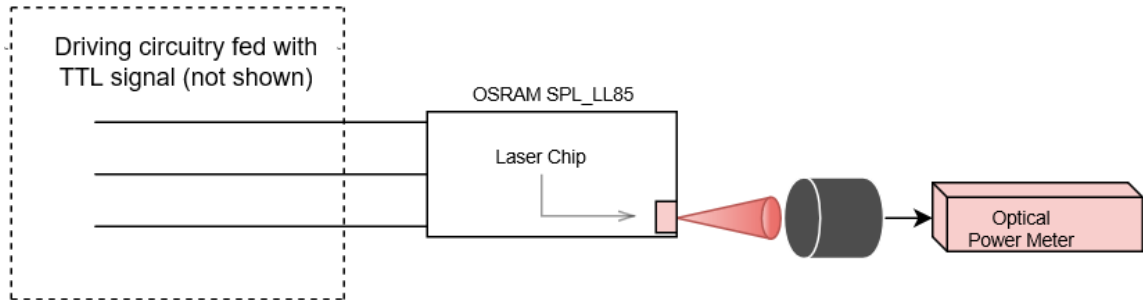

Figure 7.3-9 (permission not needed)

It is charge source that is adjusted and then the output power measured to obtain a power versus charge voltage curve similar to theoretical curve presented in Figure 7.3-10 below [39].

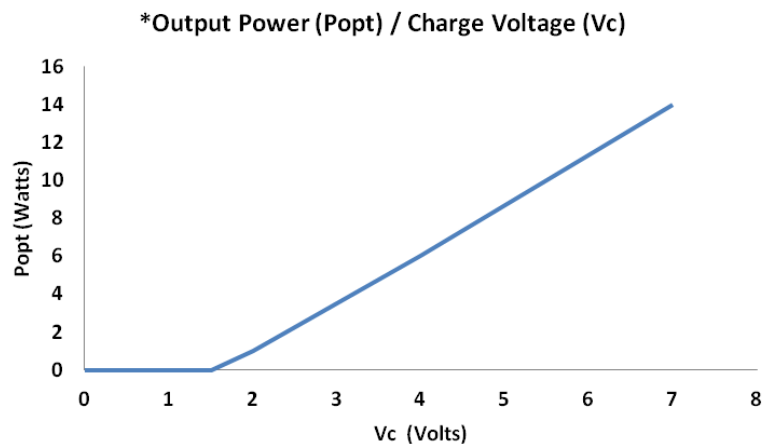

Figure 7.3-10 (permission not needed)

The figure below is very similar to the setup presented previously for measuring output optical power versus charge voltage except that the power meter is replaced by a spectrometer. The reason for this replacement is because a spectrometer offers a graphical representation of

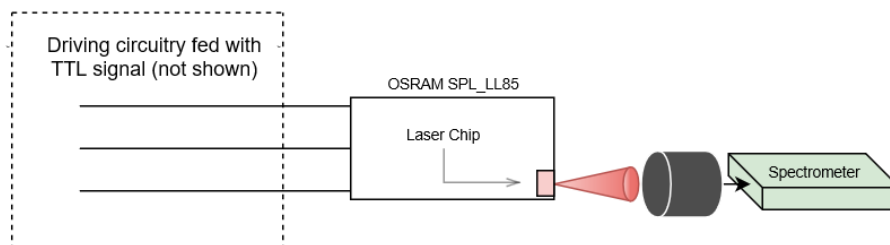

Figure 7.3-11 (permission not needed)

8.0. Administrative Content

Organizing a project of this size to be ready to present to a board of professors required a plan set up with specific steps to follow. In the beginning we took the time to brainstorm what our project would be and the end goal of how it could benefit people. After we figured out what our project was on we began researching. Our research included parts needed and how to implement them for the final prototype. After this we can design, prototype, and then finally test the system as a whole. Time management was key to getting these goals accomplished in the allotted five-month timeframe we were given. The next few sections show in detail the methods used to complete the tasks explained above.

8.1. Timeline

Milestones for the project will be kept on track by a timeline of events. This includes the milestone to achieve, the start date, and the date we are shooting to have the task accomplished. This will allow us to stay focused on meeting deadlines while also keeping each other accountable. The following chart represents our goals for the next two semesters.

Month 1 – August

The first goal after becoming a group was for us to come up with our initial project idea. Before we became a group, we had spoken to a professor about a project idea that he had for measuring the gradient of a landscape optically. From there we developed other ideas that involved measuring distance optically. We decided that we would create a device that would not only allow us to grow as engineers, but to help people as well. Helping the blind navigate by using optics was what we came up with.

Month 2 – September

In the second month, we decided the roles each group member would play, and what their responsibilities would be. These were determined by each individual's strengths. This was a Segway for our initial project document and research. The duties were split as evenly as possible but with the understanding that each team member would be available to help should anyone need them. We successfully completed and turned in the initial project document and continued researching our respective topics.

Month 3 – October

The third month consisted of continuing research and ordering parts. Fortunately, we learned that students can order sample parts from electronic component companies such as Texas Instruments (TI), so we began ordering

parts. We also spoke with professors and professionals in the tech industry as part of our research. We were fortunate enough to have a major component donated to us by Dr. Mercedeh Khajavikhan. Later on, she also allowed us to borrow some equipment to help test some of the components that were ordered. Organization of the table of contents began as well, along with beginning to write our first draft of the final documentation of our project.

Month 4 - November

By this time, we had received the majority of our parts. After finishing up our table of contents, and subsequently our first draft, we began to devise plans on how we would test our components. We made arrangements to have a spot inside of the senior design lab in CREOL and ordered safety glasses to be able to test the laser diode safely. Throughout the month we continued to work on the final draft of our documentation after receiving feedback from the professors.

TIMELINE		
Milestone	Start Date	End Date
Select Team	08/22/16	08/25/16
Initial Project Idea	08/22/16	08/26/16
Role Assignment	09/08/16	09/11/16
Initial Project Document	09/09/16	
Research	09/09/16	10/07/16
Order Parts for Prototype	10/07/16	10/21/16
Test Components	10/21/16	10/30/16
Table of Contents	11/03/16	
1st Draft of Documentation	11/10/16	
Testing Schematics	11/28/16	
Final Document	12/04/16	
Prototype	11/29/16	01/15/17
PCB Design and Manufacture	01/15/17	02/27/17
Final Project Assembly	02/27/17	03/29/17
Troubleshooting	03/30/17	05/01/17
Final Project	04/28/17	
Presentation	05/05/17	

Table 8.1 - Timeline

8.2. Budget

This project will be completely funded by its group members. In the beginning of the semester, each member agreed to provide \$250 towards the project as a worst case scenario. This put the project funds at \$1000 as the maximum expected project cost for electrical engineer majors. The projected cost of the project is far below the maximum budget thanks, in part, to the avalanche photodiode being donated by Dr. Mercedeh Khajavikhan from the College of Optics and Photonics. It is also due to the group being able to use free samples obtained from the Texas Instruments website. This helped us reach a total budget of less than \$250. In contrast, the average cost of a low end laser rangefinder spans anywhere from \$120-\$300 depending on the features desired. Considering we are not ordering parts in bulk and we are not producing mass units of these devices, \$250 is a reasonable amount to spend.

BUDGET				
Components	Price	Quantity	Total	
Lens	\$ 10.00	2	\$ 20.00	
Filter	\$ 10.00	1	\$ 10.00	
Laser Diode	\$ 20.00	1	\$ 20.00	
Laser Driver	\$ -	1	\$ -	*Donated
Receiver	\$ -	1	\$ -	*Donated
Timer	\$ -	1	\$ -	*Donated
Microcontroller	\$ -	1	\$ -	*Donated
Power Supply	\$ 5.00	1	\$ 5.00	
Vibrating Motor	\$ 4.00	2	\$ 8.00	
Enclosure	\$ 5.00	1	\$ 5.00	
PCB	\$ 25.00	4	\$ 100.00	
Sub Total			\$ 168.00	
Tax	7.25%		\$ 12.18	
Shipping			\$ 20.00	
Miscellaneous	20% of Total		\$ 36.04	
Grand Total			\$ 236.22	

Table 8.2 - Budget

8.3. Version Control

To help keep our prototyping and testing of our project as efficient as possible we needed to develop some type of version control system. As a group of four, it is important to have this system in place so we remain organized, and so we won't repeat the same mistake more than once. The best choice for our project which is mostly hardware based is to take the simple route of using logbooks. We have decided to leave the logbook in the CREOL senior design lab where we will be working on testing and prototyping our project. This helps with the fact that we might not all be in the lab at the same time. The information lets a group member know what he missed so the same thing is not repeated. We have one table in the CREOL senior design lab so it will be limited space when all four of us are working on the project. This will be our main challenge, and we will need to work together to keep the logbook in order and up to date.

We chose logbooks because it is a simple solution that works best with our project and group members. Each part will be logged on separate pages with the time and date. We will also keep the information on how the parts work together and the different versions of prototyping. As the project progresses different versions will develop.

The reason we benefit from writing down what we do in logbooks is because it can help us to isolate any problems we run into. When we find a problem we can find the exact steps we took that might have been wrong in the procedure, on a specific date and time. This isolation of parts and procedures will help us to test different versions to solve the problems we run into. With the use of a logbook we will be able to work on our individual parts as a group and to be able to understand how each part works in regards to the final working version.

9.0. Conclusion

We set out to create an effective supplement and improvement on the current technology available to the blind and visually impaired. The cane is great and has served its purpose, but in today's fast paced world the blind and visually impaired could use a boost to this old technology.

Starting from the beginning of our Senior Design we weren't that confident or sure on what route to take to create this product. Although, through the process it took to complete this document, it has helped to set us up to reach our goal. In order to accomplish this each group member has had to contribute separately on distinct individual parts of the project. Since we had never worked together prior to this we didn't know what to expect from each other. Luckily, the four of us have become a solid Senior Design group. By communicating constantly and pushing each other to reach our goals we have succeeded in completing this detailed documentation. Through the process, we have found out we work well as a team and are confident looking forward to the next part of the project, which is the final assembly.

By far the best part of the documentation that helped us out the most was the researching portion. As the timeline shows this was also the longest part of the process. We started out with basic knowledge and understandings of the project, but no concrete ideas on specifics. But with the time spent studying other projects and technologies we now have the knowledge to pick the best parts and methods to achieve our final design.

While research helped us know how to make the project work, talking to the people at the Rehabilitation Center for the Blind and Visually Impaired has help to give us the direction we are taking. Although we have not invented something new, as technology like this is already available to the public, we consider our contribution for improvement is that of a better price. Instead of using the much more common ultrasonic technology, we decided to go with a lidar rangefinder. Our simple design will make it more cost effective compared to the competition. By making the rangefinder cheaper the product can reach a larger population and help out more people unable to purchase what is currently available. If those with the money can afford the products currently available they are the better option, however when talking with the people from the Rehabilitation Center for the Blind and Visually Impaired, it doesn't seem like the current technology is that common to the blind and visually impaired community. White canes are still the most popular option for the blind or visually impaired. Our project was made to give the people who can't afford these products the chance to have a rangefinder that supplements their cane. It might not have all the 'bells and whistles' of the competition; however, it will get the job done which is what we set out to do.

Appendices

Appendix A - Copyright Permissions



Steve Hoefler <steve@grathio.com>

Yesterday, 1:40 PM

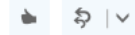

Hi Henry,

Feel free to use any Tacit images you want for your project.

Best of luck to you,

-Steve

Steve Hoefler

twitter: [@grathio](#) web: [Grathio.com](#)



Henry Schmitz

Yesterday, 11:30 AM

steve@grathio.com

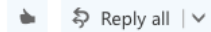

Sent Items

Full Name: Henry Schmitz

Hello,

I am a senior engineering student at the University of Central Florida and I am working on my senior design project. I would like to use a picture of the overhand graphic of the Tacit from your website in my paper and I wanted to ask to make sure it was okay. This paper is for a design class and will not be published or used to make money.

Thank you,

Henry Schmitz

Name:

Henry Schmitz

E-Mail Address:

hlschmitz@knights.ucf.edu

Enquiry:

Full Name: Henry Schmitz

Hello,

I am a senior engineering student at the University of Central Florida and I am working on my senior design project. I would like to use a picture of the 'Ultracane sensor range' from your website in my paper and I wanted to ask to make sure it was okay. This paper is for a design class and will not be published or used to make money.

Thank you,

Henry Schmitz



wilfredo ortiz <wilfredo.ortiz@gmail.com>

Permission to use image

2 messages

wilfredo ortiz <wilfredo.ortiz@gmail.com>
 To: admin@physics-and-radio-electronics.com

Sun, Dec 4, 2016 at 11:35 PM

To whom it may concern:

My name is Wilfredo Ortiz and I am a student at the University of Central Florida. I would like to request permission to use the following image in my senior design document that includes a section on photodiodes. I look forward to your response.

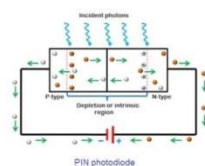

Thank You,

Wilfredo Ortiz
 Photonic Science and Engineering Undergraduate Student
 University of Central Florida
 College of Optics and Photonics
 Cell: 910-797-2979

admin@physics-and-radio-electronics.com <admin@physics-and-radio-electronics.com> Mon, Dec 5, 2016 at 9:25 AM
 To: wilfredo ortiz <wilfredo.ortiz@gmail.com>

On 2016-12-05 04:35, wilfredo ortiz wrote:
 To whom it may concern:

My name is Wilfredo Ortiz and I am a student at the University of Central Florida. I would like to request permission to use the following image in my senior design document that includes a section on photodiodes. I look forward to your response.

Thank You,

Wilfredo Ortiz
 Photonic Science and Engineering Undergraduate Student
 University of Central Florida
 College of Optics and Photonics

Cell: 910-797-2979
 Hello,

I am giving permission to use this image only for the purpose you have mentioned.



wilfredo ortiz <wilfredo.ortiz@gmail.com>

Permission request to use image

2 messages

wilfredo ortiz <wilfredo.ortiz@gmail.com>
To: info@pixelteq.com

Sun, Dec 4, 2016 at 11:48 PM

To whom it may concern:

My name is Wilfredo Ortiz and I am a student at the University of Central Florida. I would like to request permission to use the following image in my senior design document that includes a section on optical filters. I look forward to your response.

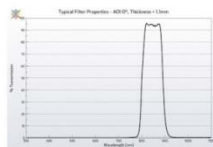

Thank You,

Wilfredo Ortiz
Photonic Science and Engineering Undergraduate Student
University of Central Florida
College of Optics and Photonics
Cell: 910-797-2979

John Dougherty <john.dougherty@pixelteq.com>
To: wilfredo ortiz <wilfredo.ortiz@gmail.com>

Mon, Dec 5, 2016 at 8:06 AM

Sure please feel free to use it in your senior design document. Thank you for asking.

From: wilfredo ortiz [mailto:wilfredo.ortiz@gmail.com]
Sent: Sunday, December 4, 2016 11:49 PM
To: Info Requests <info@pixelteq.com>
Subject: Permission request to use image

[Quoted text hidden]

Gmail - Permission to use image

<https://mail.google.com/mail/u/0/?ui=2&ik=181bd6e58e&view=pt&sea...>

wilfredo ortiz <wilfredo.ortiz@gmail.com>

Permission to use image

2 messages

wilfredo ortiz <wilfredo.ortiz@gmail.com>

Sun, Dec 4, 2016 at 11:08 PM

To: info@julight.it

To whom it may concern:

My name is Wilfredo Ortiz and I am a student at the University of Central Florida. I would like to request permission to use the following image in my senior design document that includes a section on range finding. I look forward to your response.

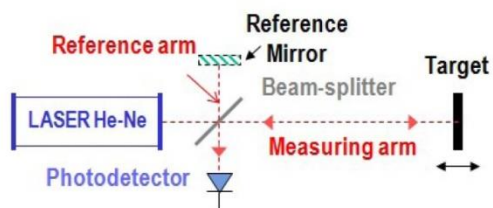

Thank You

Wilfredo Ortiz

Photonic Science and Engineering Undergraduate Student
 University of Central Florida
 College of Optics and Photonics
 Cell: 910-797-2979

Guido Giuliani - JULIGHT S.r.l. <giuliani@julight.it>

Mon, Dec 5, 2016 at 6:33 AM

To: wilfredo ortiz <wilfredo.ortiz@gmail.com>

Cc: "JULIGHT S.r.l." <info@julight.it>

Hello,

usage if image is granted.

Best regards

Guido Giuliani
 Chief Technology Officer

Julight S. r. l.

Gmail - Permission to use image

<https://mail.google.com/mail/u/0/?ui=2&ik=181bd6e58e&view=pt&sea...>

Polo Tecnologico - Via Cuzio 42
 I-27100 Pavia, Italy
 web: www.julight.it
 email: giuliani@julight.it
 mobile: +39 347 7248106

This e-mail and any file transmitted with it are confidential and solely for the use of individuals or entities to whom they are addressed. If you have received this e-mail in error please notify the sender and delete the material received.

Questo messaggio e qualsiasi allegato con esso sono confidenziali ed esclusivamente ad uso dei destinatari ai quali sono indirizzati. Se avete ricevuto questo messaggio per errore, informate per cortesia il mittente e cancellate le informazioni ricevute.
 [Quoted text hidden]

Gmail - Permission request to use image

<https://mail.google.com/mail/u/0/?ui=2&ik=181bd6e58e&view=pt&sea...>wilfredo ortiz <wilfredo.ortiz@gmail.com>

Permission request to use image

2 messages

wilfredo ortiz <wilfredo.ortiz@gmail.com>
 To: capnfatz@gmail.com

Sun, Dec 4, 2016 at 11:43 PM

Hello Sir,

My name is Wilfredo Ortiz and I am a student at the University of Central Florida. I would like to request permission to use the following image in my senior design document that includes a section on op amps. I look forward to your response.

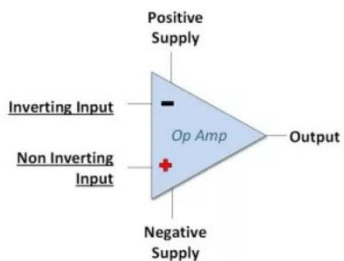

Thank You,

Wilfredo Ortiz

Photonic Science and Engineering Undergraduate Student
 University of Central Florida
 College of Optics and Photonics
 Cell: 910-797-2979

Capn Fatz <capnfatz@gmail.com>
 To: wilfredo ortiz <wilfredo.ortiz@gmail.com>

Mon, Dec 5, 2016 at 2:26 AM

You have my permission
 [Quoted text hidden]

Gmail - Permission request to use image

<https://mail.google.com/mail/u/0/?ui=2&ik=181bd6e58e&view=pt&sea...>

wilfredo ortiz <wilfredo.ortiz@gmail.com>

Permission request to use image

4 messages

wilfredo ortiz <wilfredo.ortiz@gmail.com>

Sun, Dec 4, 2016 at 11:46 PM

To: talking@tpg.com.au

Hello Sir,

My name is Wilfredo Ortiz and I am a student at the University of Central Florida. I would like to request permission to use the following image in my senior design document that includes a section on op amps. I look forward to your response.

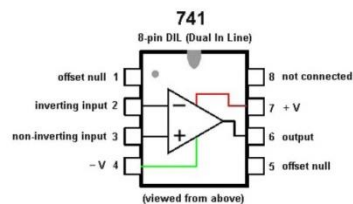

Thank You,

Wilfredo Ortiz

Photonic Science and Engineering Undergraduate Student
 University of Central Florida
 College of Optics and Photonics
 Cell: 910-797-2979

Colin Mitchell <talking@tpg.com.au>

Mon, Dec 5, 2016 at 12:06 AM

To: wilfredo ortiz <wilfredo.ortiz@gmail.com>

This is not my image. It is a standard image for everyone to use.

All images like this can be used by anyone.

no-one in particular has put anything special on the image or drawn a cartoon or anything that the person can say is HIS.

Gmail - Permission request to use image

<https://mail.google.com/mail/u/0/?ui=2&ik=181bd6e58e&view=pt&sea...>

Thank you. By the way your website is awesome!

Wilfredo Ortiz
 Photonic Science and Engineering Undergraduate Student
 University of Central Florida
 College of Optics and Photonics
 Cell: 910-797-2979

[Quoted text hidden]

Colin Mitchell <talking@tpg.com.au>
 To: wilfredo ortiz <wilfredo.ortiz@gmail.com>

Mon, Dec 5, 2016 at 12:31 AM

You will learn more for my website than any of the courses you are taking.

----- Original Message -----

From: wilfredo ortiz

[Quoted text hidden]

Re: LAE Contact: - Wilfredo Ortiz

<https://outlook.office.com/owa/?viewmodel=ReadMessageItem&ItemI...>

Re: LAE Contact:

Mon 12/5/2016 6:13 AM

Inbox

To: Wilfredo Ortiz <wortiz8@knights.ucf.edu>;

Hi Wilfrido

Thats fine, good luck with your project.

Regards

Eric Coates

On Mon, Dec 5, 2016 at 4:38 AM, Wilfredo Ortiz <wortiz8@knights.ucf.edu> wrote:

To: Webmaster

From:

First Name: Wilfredo

Last Name: Ortiz

wortiz8@knights.ucf.edu

Organisation/School/College/ Company
 University of Central Florida

Country
 USA

Message:
 Hello,

My name is Wilfredo Ortiz and I am a student at the University of Central Florida. I would like to request permission to use the an image from your website in my senior design document that includes a section on photodiodes. I look forward to your response.

Thank You

Sent from (ip address): 104.136.107.165 (104-136-107-165.res.bhn.net)

Date/Time: December 5, 2016, 4:38 am GMT

Coming from (referer):

<http://www.learnabout-electronics.org/Site/contact.php>

Using (user agent): Mozilla/5.0 (Windows NT 10.0; Win64; x64)

AppleWebKit/537.36 (KHTML, like Gecko) Chrome/54.0.2840.99

Safari/537.36

Appendix B - References

- [1] "Encyclopedia Britannica Online," *Encyclopedia Britannica Online*. [Online]. Available: <http://kids.britannica.com/comptons/art-106626/A-cutaway-diagram-show-a-typical-alkaline-cell-with-a>. [Accessed: 05-Nov-2016].
- [2] "1300 nm MEMS VCSEL Swept Laser Source," *1300 nm MEMS VCSEL Swept Laser Source*. [Online]. Available: https://www.thorlabs.us/newgrouppage9.cfm?objectgroup_id=7109. [Accessed: 18-Oct-2016].
- [3] "8 Difference Between Nimh vs Lipo Battery," *Upower Battery*, Dec-2016. [Online]. Available: <http://www.skylightupower.com/8-difference-of-nimh-vs-lipo-battery/>. [Accessed: 09-Nov-2016].
- [4] "About Abet | ABET," *ABET About Abet Comments*. [Online]. Available: <http://www.abet.org/about-abet/>. [Accessed: 02-Dec-2016].
- [5] "Adafruit DRV2605 Haptic Controller Breakout," *Overview | Adafruit DRV2605 Haptic Controller Breakout | Adafruit Learning System*. [Online]. Available: <https://learn.adafruit.com/adafruit-drv2605-haptic-controller-breakout/overview>. [Accessed: 01-Dec-2016].
- [6] "ANSI WebStore - American National Standards," *ANSI WebStore - American National Standards*. [Online]. Available: <http://webstore.ansi.org/default.aspx>. [Accessed: 01-Dec-2016].
- [7] "ATmega328P," *ATmega328P*. [Online]. Available: <http://www.atmel.com/devices/ATMEGA328P.aspx?tab=overview>. [Accessed: 03-Nov-2016].
- [8] "BrainPort V100 Vision Aid," *BrainPort V100 Vision Aid*. [Online]. Available: <http://www.wicab.com/>. [Accessed: 02-Dec-2016].
- [9] "Characteristics of Phototransistors and Photodarlington," *Characteristics of Phototransistors and Photodarlington*. [Online]. Available: http://www.johnloomis.org/ece445/topics/egginc/pt_char.html. [Accessed: 04-Nov-2016].
- [10] "CorDEX Instruments." [Online]. Available: <http://static.transcat.com/media/pdf/cordex-laser-distance-meters.pdf>. [Accessed: 02-Nov-2016].
- [11] "CSCI 445 Amin Atrash Ultrasound ... - www-robotics.usc.edu." [Online]. Available: http://www.bing.com/cr?IG=9257E5F9D2B04CC5AB8A1F7E5EB9FB46&CID=30A5C10E41B168BE24D8C8EC408069D5&rd=1&h=VEaT-YqvhreysHcO0jaK-r0yE9_ue6SNo2VZp5MWQII&v=1&r=http://www-robotics.usc.edu/~aatrash/cs445/lec08.pdf&p=DevEx,5042.1. [Accessed: 05-Nov-2016].
- [12] "Current to Voltage Converter - Analog Electronics Tutorials," *Analog Electronics Tutorials*. [Online]. Available: <http://electronics-course.com/current-voltage-converter>. [Accessed: 15-Nov-2016].
- [13] "Datasheet catalog for integrated circuits, diodes, triacs, and other semiconductors, view," *Datasheet catalog for integrated circuits, diodes, triacs, and other semiconductors, view*. [Online]. Available:

- <http://datasheetcatalog.com/>. [Accessed: 04-Nov-2016].
- [14] “Develop Standards,” *IEEE-SA - How Are Standards Made?* [Online]. Available: <https://standards.ieee.org/develop/process.html>. [Accessed: 01-Dec-2016].
- [15] DIODES INCORPORATED. (n.d.). *1N5817 - 1N5819 1.0A SCHOTTKY BARRIER RECTIFIER* [Brochure]. Author.
- [16] “DRV2605 - TI.com.” [Online]. Available: http://www.bing.com/cr?IG=F1BA6E799D6E4CE1858B4E03EFD32940&CID=2AB05DF9AF0A6D992C37541BAE3B6C03&rd=1&h=w-MTO3JBklz_zXk419UTxrTdtrA_rh_Dlpl4LsrZS44&v=1&r=http://www.ti.com/product/drv2605&p=DevEx,5090.1. [Accessed: 05-Nov-2016].
- [17] “DRV2605EVM-CT ERM/LRA Haptic Driver Evaluation,” *DRV2605EVM-CT ERM/LRA Haptic Driver Evaluation - DRV2605EVM-CT - TI Tool Folder*. [Online]. Available: <http://www.ti.com/tool/drv2605evm-ct>. [Accessed: 06-Nov-2016].
- [18] “DS00 - Laser Range Finder Manual Rev 00 - LightWare.” [Online]. Available: http://www.bing.com/cr?IG=8F91A3AAA3F44C4293F514E39D0ADDCE&CID=2A2115A771096D8B16A11C4570386CD8&rd=1&h=8bKzoYoHhmJ OHuyk-u-3tPgYVEGqLUa8cHoZRwnQ5y8&v=1&r=http://www.lightware.co.za/download/doc/DS00%20-%20Laser%20Range%20Finder%20Manual_Rev_00.pdf&p=DevEx,5041.1. [Accessed: 03-Nov-2016].
- [19] “DS00VQ100 Laser range finder controller Data sheet - LightWare.” [Online]. Available: http://www.bing.com/cr?IG=48C1C1F452CE4849BA020FA3B2CDC137&CID=3B0A0A8A8CE861BC3F6D03688DD9604F&rd=1&h=4UwLv_PW0mDdKlzh4zSc235NvPnL9FGEzUa1tuKIYmw&v=1&r=http://www.lightware.co.za/download/doc/DS00VQ100%20-%20Laser%20Range%20Finder%20controller%20data%20sheet_Rev_01.pdf&p=DevEx,5037.1. [Accessed: 03-Nov-2016].
- [20] “Edmund Optics Inc.,” *Optics - Imaging - Photonics - Optomechanics - Lasers*. [Online]. Available: <http://www.edmundoptics.com/>. [Accessed: 01-Nov-2016].
- [21] “Electronic Components,” *Find Electronic Components | Mouser*. [Online]. Available: <http://www.mouser.com/ProductDetail/Texas-Instruments/>. [Accessed: 01-Nov-2016].
- [22] “Electronics Bus,” *ElectronicsBus RSS*. [Online]. Available: <http://www.electronicbus.com/light-dependent-resistor-ldr-light-sensor-solar-lighting/>. [Accessed: 03-Dec-2016].
- [23] “Embedded Systems Programming and Design - Barr Group,” *Embedded Systems Programming and Design - Barr Group | Embedded Systems Experts*. [Online]. Available: <http://www.barrgroup.com/Embedded-Systems/>. [Accessed: 20-Oct-2016].
- [24] ^ Eren, H. (2003), *Electronic Portable Instruments: Design and Applications*,

- CRC Press, ISBN 0-8493-1998-6
- [25] "Forest Management Tech Tips: Rangefinder Comparison." [Online]. Available: <http://www.fs.fed.us/eng/pubs/html/98241307/98241307.html#TECH>. [Accessed: 24-Oct-2016].
- [26] rezaphd2010, "Going-the-Distance-Solids-Level-Measurement-with-Radar.pdf - Documents," *Docslide.us*, Aug-2014. [Online]. Available: <http://docslide.us/documents/going-the-distance-solids-level-measurement-with-radarpdf.html>. [Accessed: 05-Nov-2016].
- [27] D. Gonzalez, "Ultrasonic White Cane Concept," *prezi.com*, Nov-2014. [Online]. Available: <https://prezi.com/uaqztd1kulhk/ultrasonic-white-cane-concept/>. [Accessed: 01-Nov-2016].
- [28] "IEEE Standards," *IEEE-SA - The IEEE Standards Association - Home*. [Online]. Available: <http://standards.ieee.org/index.html>. [Accessed: 01-Dec-2016].
- [29] "iGlasses," *Shop Online | Ambutech*. [Online]. Available: <https://ambutech.com/shop-online/>. [Accessed: 02-Nov-2016].
- [30] S. O. Kasap, *Optoelectronics and Photonics*, 2nd ed. Upper Saddle River, New Jersey: Pearson Education, 2013.
- [31] G. Keiser, *Optical Fiber Communications*, 4th ed. New York, NY: McGraw-Hill, 2010.
- [32] E. S. S. Labs, "Choosing low-power microcontrollers by the numbers," *Embedded*. [Online]. Available: <http://www.embedded.com/design/mcus-processors-and-socs/4413368/Choosing-low-power-microcontrollers-by-the-numbers>. [Accessed: 05-Dec-2016].
- [33] "Laser Diode Circuit Schematic pdfs," *Laser Diode Circuit Schematic PDF - Ebooks-kings.com*. [Online]. Available: <http://ebooks-kings.com/pdf/laser-diode-circuit-schematic>. [Accessed: 02-Dec-2016].
- [34] "Laser ranging: a critical review of usual techniques for ..." [Online]. Available: http://www.bing.com/cr?IG=FFF9221276B74BB09B4E723A57F23E08&CID=370953D7B9BA60AF18275A35B88B61C8&rd=1&h=d_B9l1f2xve6dVK4CQEFgyoTilVlgzycruuoqRPmEj8&v=1&r=http://www.utdallas.edu/~aik/en/LASERCLASS/laserprinlipels.pdf&p=DevEx,5064.1. [Accessed: 02-Nov-2016].
- [35] "Learnabout Electronics," *Photodiodes*. [Online]. Available: http://www.learnabout-electronics.org/Semiconductors/diodes_27.php. [Accessed: 05-Nov-2016].
- [36] "LightWare Optoelectronics (Pty) Ltd," *LightWare Optoelectronics (Pty) Ltd*. [Online]. Available: <http://www.lightware.co.za/shop/en/>. [Accessed: 24-Oct-2016].
- [37] T. B. Markus-Christian Amann, Marc Lescure, Risto Myllyla, Marc Rioux, "Laser ranging: a critical review of usual techniques for distance measurement," *Opt. Eng.*, vol. 40, p. 10, January 2001 2000.
- [38] "Meet The Tacit Project. It's Sonar For The Blind. – Grathio Labs," *Grathio Labs Meet The Tacit Project Its Sonar For The Blind Comments*. [Online].

- Available: <http://grathio.com/2011/08/meet-the-tacit-project-its-sonar-for-the-blind/>. [Accessed: 05-Nov-2016].
- [39] Morgott/OSRAM, S. (2004, November 3). *Operating the Pulsed Laser Diode SPL LLxx* [Application Note].
- [40] "MSP430F5529 USB LaunchPad Evaluation Kit," *MSP430F5529 USB LaunchPad Evaluation Kit - MSP-EXP430F5529LP - TI Tool Folder*. [Online]. Available: [http://www.ti.com/tool/msp-exp430f5529lp?keyMatch=MSP430F5529 LaunchPad&tisearch=Search-EN-Everything](http://www.ti.com/tool/msp-exp430f5529lp?keyMatch=MSP430F5529+LaunchPad&tisearch=Search-EN-Everything). [Accessed: 06-Nov-2016].
- [41] "MSP430g2553," *MSP430g2553 - MSP Low-Power Microcontroller Forum - MSP Low-Power Microcontrollers - TI E2E Community*. [Online]. Available: <https://e2e.ti.com/support/microcontrollers/msp430/f/166/t/404387>. [Accessed: 05-Nov-2016].
- [42] "Newport CA-1." [Online]. Available: <https://www.bing.com/cr?IG=1EAB2D8FA04B4B5AB768E25252D13993&CID=18851FA842DF67BB1E34164A43EE66C7&rd=1&h=Jb19e6iKD-mJk6kxLRu8UIGU874HMYkInjnswiGUsME&v=1&r=https://www.newport.com/p/CA-1&p=DevEx,5080.1>. [Accessed: 05-Dec-2016].
- [43] "Optimizing microcontroller power efficiency for ultra-low-power designs," *Embedded Computing Design*. [Online]. Available: <http://embedded-computing.com/articles/optimizing-power-efficiency-ultra-low-power-designs/>. [Accessed: 02-Nov-2016].
- [44] "Overview - smartcane," *smartcane*. [Online]. Available: <http://smartcane.saksham.org/overview/>. [Accessed: 05-Nov-2016].
- [45] @resistorguide, "Photo resistor - Light Dependent Resistor (LDR) » Resistor Guide," *Light Dependent Resistor (LDR) » Resistor Guide*. [Online]. Available: <http://www.resistorguide.com/photoresistor/>. [Accessed: 08-Nov-2016].
- [46] "Phototransistor Tutorial," *Phototransistors | Photo Transistor Tutorial | Radio-Electronics.Com*. [Online]. Available: http://www.radio-electronics.com/info/data/semicond/phototransistor/photo_transistor.php. [Accessed: 07-Nov-2016].
- [47] "Pigtailed, Distributed Feedback (DFB) Single-Frequency Lasers with Internal Isolator," *Pigtailed, Distributed Feedback (DFB) Single-Frequency Lasers with Internal Isolator*. [Online]. Available: https://www.thorlabs.com/newgrouppage9.cfm?objectgroup_id=7928. [Accessed: 08-Nov-2016].
- [48] "Principles Of Measurement Used By Laser Sensors," *Principles Of Measurement Used By Laser Sensors And Scanners*. [Online]. Available: <http://www.acuitylaser.com/measurement-principles>. [Accessed: 05-Nov-2016].
- [49] "Pros and Cons of a Laser Rangefinder (with images) · leobgeorge," *Storify*. [Online]. Available: <https://storify.com/leobgeorge/pros-and-cons-of-a-laser-rangefinder>. [Accessed: 05-Nov-2016].
- [50] "Question for the Oscilloscope Experts," *Electronics Forum (Circuits,*

- Projects and Microcontrollers*). [Online]. Available: <http://www.electro-tech-online.com/threads/question-for-the-oscilloscope-experts.145961/page-4>. [Accessed: 05-Nov-2016].
- [51] "Robot Reviews," *Robots and Laser RangeFinders - Part 1 | Robot Reviews*. [Online]. Available: <http://www.robotreviews.com/blog/eigenlance/robots-and-laser-rangefinders-part-1>. [Accessed: 03-Nov-2016].
- [52] "Search Engine for Standards - NSSN," *Search Engine for Standards - NSSN*. [Online]. Available: <http://www.nssn.org/default.aspx>. [Accessed: 01-Dec-2016].
- [53] L. P. Sicking, "RANGEFINDER COMPARISON," 1998. [Online]. Available: <http://www.fs.fed.us/eng/pubs/html/98241307/98241307.html#TECH>.
- [54] "Signal to Noise Ratio, SNR," *Signal to Noise Ratio | Radio Receiver SNR | Radio-Electronics.com*. [Online]. Available: <http://www.radio-electronics.com/info/rf-technology-design/rf-noise-sensitivity/receiver-signal-to-noise-ratio.php>. [Accessed: 05-Nov-2016].
- [55] "Single mode laser diode at 850nm," *Single mode laser diode at 850nm*. [Online]. Available: <http://www.qphotonics.com/Single-mode-laser-diode-150mW-850nm.html>. [Accessed: 01-Dec-2016].
- [56] S. K. B. Ben G. Streetman, *Solid State Electronic Devices*. Upper Saddle River, NJ: Pearson Education, 2015.
- [57] T. R., "SNIPER 101 Part 85 - LASER Rangefinder Advantages and Limitations," *YouTube*, 2014. [Online]. Available: http://www.youtube.com/watch?v=0_JZeW7Vtiw. [Accessed: 05-Nov-2016].
- [58] "Stanford University Laser Safety Manual," *Stanford University Laser Safety Manual*. [Online]. Available: <https://web.stanford.edu/dept/EHS/prod/researchlab/radlaser/laser/procedures/index.html>. [Accessed: 01-Dec-2016].
- [59] H. C. Sukhan Lee, Kwang-Joon Yoon, Jangmyung Lee. (2013). *Advances in Intelligent Systems and Computing*. 193.
- [60] S. M. Sze, *Semiconductor devices, physics and technology*, 2nd ed. New York: Wiley, John & Sons, 2001
- [61] "TDC7200 Evaluation Module," *TDC7200 Evaluation Module - TDC7200EVM - TI Tool Folder*. [Online]. Available: <http://www.ti.com/tool/tdc7200evm>. [Accessed: 06-Nov-2016].
- [62] "TDC7201 (ACTIVE)," *TDC7201 | Time to Digital Converter | Ultrasonic Sensing | Description & parametrics*. [Online]. Available: <http://www.ti.com/product/tdc7201>. [Accessed: 04-Dec-2016].
- [63] "The Hobby Center for the Performing Arts." [Online]. Available: https://www.bing.com/cr?IG=EFE8FA115C5A46DA91E2A82A268FC6EF&CID=26B255AE145F656227D05C4C156E64F4&rd=1&h=zfm-V7FXEkdPMr0mURIA_DuhtkBgtiDxVT4hMLIKs9M&v=1&r=https://www.thehobbycenter.org/&p=DevEx,5087.1. [Accessed: 05-Dec-2016].
- [64] "Trace Degradation Analysis of Lithium-Ion Battery Components," *Research & Development*, 2016. [Online]. Available: <http://www.rdmag.com/article/2014/04/trace-degradation-analysis-lithium->

- ion-battery-components. [Accessed: 05-Nov-2016].
- [65] “Transistor–transistor logic,” *Wikipedia*. [Online]. Available: https://en.wikipedia.org/wiki/Transistor–transistor_logic. [Accessed: 02-Dec-2016].
- [66] “TRF371125EVM Evaluation Module,” *TRF371125EVM Evaluation Module - TRF371125EVM - TI Tool Folder*. [Online]. Available: <http://www.ti.com/tool/trf371125evm>. [Accessed: 05-Nov-2016].
- [67] “TRF371135 Wide Bandwidth Integrated Direct Down Conversion.” [Online]. Available: <http://www.ti.com/lit/ds/symlink/trf371135.pdf>. [Accessed: 23-Oct-2016].
- [68] “Ultracane - a safer way to travel.....,” *UltraCaneputting the world at your fingertips*. [Online]. Available: <https://www.ultracane.com/>. [Accessed: 05-Nov-2016].
- [69] “Understand and apply the transimpedance amplifier (Part 1 of 2),” *Planet Analog - Articles - Understand and apply the transimpedance amplifier (Part 1 of 2)*. [Online]. Available: http://www.planetanalog.com/document.asp?doc_id=527534&site=planetanalog. [Accessed: 02-Dec-2016].
- [70] “UNITED STATES DEPARTMENT OF LABOR,” *OSHA Technical Manual (OTM) | Table of Contents | Occupational Safety and Health Administration*. [Online]. Available: https://www.osha.gov/dts/osta/otm/otm_toc.html. [Accessed: 20-Nov-2016].
- [71] “What is RISC?,” *What is RISC?* [Online]. Available: <http://cs.stanford.edu/people/eroberts/courses/soco/projects/risc/whatis/index.html>. [Accessed: 05-Nov-2016].
- [72] “What’s All This Transimpedance Amplifier Stuff, Anyhow? (Part 1),” *Analog content from Electronic Design*. [Online]. Available: <http://electronicdesign.com/analog/whats-all-transimpedance-amplifier-stuff-anyhow-part-1>. [Accessed: 05-Nov-2016].
- [73] “Why use a Laser Distance Meter? Understanding the.” [Online]. Available: <http://www.bing.com/cr?IG=D93254218F894F3FA212ECDE2FCE73CF&CID=1BB5EEF842EF6306264BE71A43DE62AF&rd=1&h=oZfYbClnFNveq8Te-WT7-Ve7SS2IE9V10SMz434g7ZI&v=1&r=http://www.transcat.com/media/pdf/cordex-laser-distance-meters.pdf&p=DevEx,5085.1>. [Accessed: 03-Dec-2016].
- [74] “Xilinx University Program,” *University*. [Online]. Available: <http://www.xilinx.com/support/university.html>. [Accessed: 10-Nov-2016].
- [75] “Zinc-Carbon Batteries,” *Molecular Expressions*. [Online]. Available: <http://micro.magnet.fsu.edu/electromag/electricity/batteries/zinccarbon.html>. [Accessed: 20-Oct-2016].
- [76] “EL7104,” EL7104. [Online]. Available: <http://www.intersil.com/en/products/power-management/mosfet-drivers/low-side-fet-drivers/EL7104.html>. [Accessed: 05-Dec-2016].