



Group 25

Jonathan Kerbelis
Eric Downey
Harold Frech

Computer Engineering
Computer Engineering
Electrical Engineering

QwikBox

Live Video Capture and Upload Device

Agenda

- ▶ System Overview
- ▶ Specific Part Information
- ▶ Mobile Application
- ▶ PCB Design
- ▶ Software and Hardware Testing
- ▶ Budget / Difficulties

Group Roles

Jonathan Kerbelis
Eric Downey
Harold Frech

App Development
NUC Development
PCB Design

Purpose of the Qwikbox

- ▶ QwikCut company hires cameramen to record sporting events
- ▶ They need a system that will capture, encode, and upload video
- ▶ A system that will perform in real time
- ▶ It must store the smallest possible file size
- ▶ Needs both Wifi and cellular network capabilities

Up Next

- ▶ **System Overview**
- ▶ Specific Part Information
- ▶ PCB Design
- ▶ Mobile Application
- ▶ Software and Hardware Testing
- ▶ Budget / Difficulties

Design Components

- ▶ Large battery
- ▶ Intel NUC
- ▶ HDMI to USB capture device
- ▶ PCB with Verizon Skywire modem
- ▶ Mobile application
- ▶ H.265 encoding

System Overview

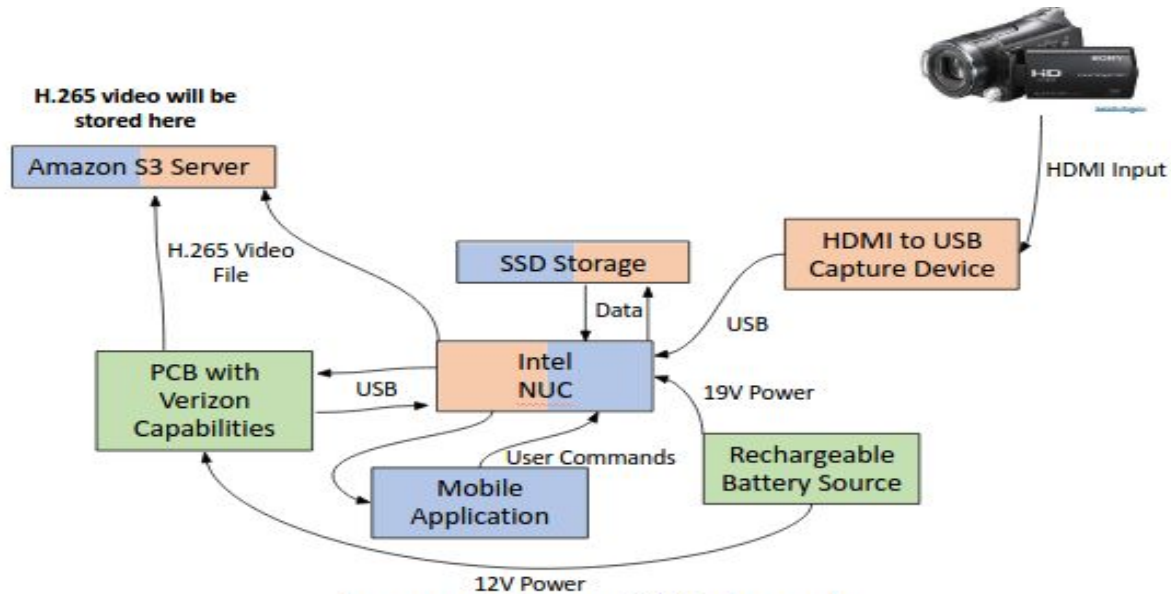

Personnel Responsibility Legend



Harold
Frech



Jonathan
Kerbelis



Eric
Downey

Up Next

- ▶ System Overview
- ▶ **Specific Part Information**
- ▶ PCB Design
- ▶ Mobile Application
- ▶ Software and Hardware Testing
- ▶ Budget / Difficulties

Rechargeable Battery



Main power supply for all components

- ▶ Price: \$52.00
- ▶ 26000 mAh capacity
- ▶ Multiple power outputs
- ▶ Can select output voltage level
- ▶ Has lights that show current charge level

Magewell HDMI to USB 3.0

Converts HDMI input to USB 3.0 output

- ▶ Price: \$140.00
- ▶ Captures full 1080p HD video
- ▶ Interface conversion done through hardware
- ▶ No drivers necessary for functionality
- ▶ Powered via USB 3.0 port



Skywire™ 4G LTE Embedded Modem

Telit E910SVG chipset

- ▶ Price: \$130.00
- ▶ 20-pin connections
- ▶ Will be implemented into PCB
- ▶ Features 4G LTE speeds on Verizon's Wireless network



Intel NUC

7th Generation Intel Core i5-7260U

- ▶ Price: \$350.00
- ▶ Supports native H.265 hardware encoding via QuickSync
- ▶ Has 4GB DDR4 memory and 256GB SSD storage
- ▶ Best price vs performance available



Amazon Web Services

- ▶ Amazon is able to provide a high-end remote storage server
- ▶ Multiple tiers of service are available for S3 service
- ▶ Fully controllable platform

Notable companies that use Amazon Web Services:

- ▶ Spotify
- ▶ Netflix
- ▶ Slack



Up Next

- ▶ System Overview
- ▶ Specific Part Information
- ▶ **PCB Design**
- ▶ Mobile Application
- ▶ Software and Hardware Testing
- ▶ Budget / Difficulties

PCB Schematic

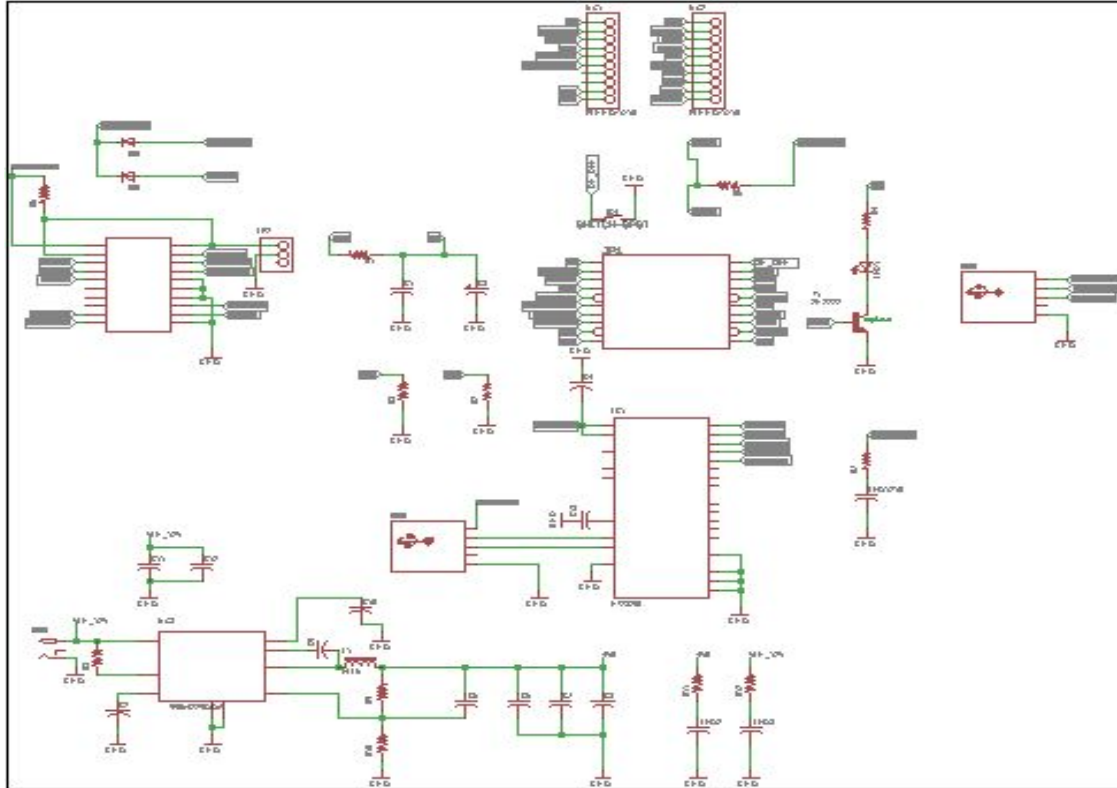

Power Regulator

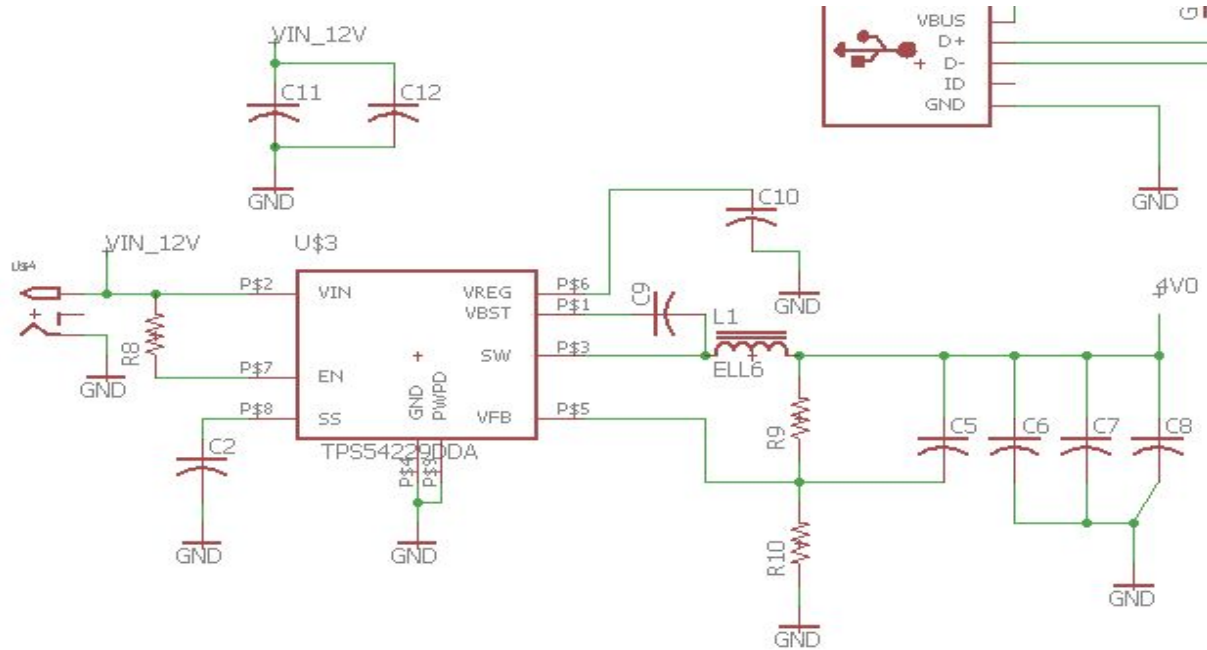

Power regulator steps down the 16 volts to 4 volts

USB to UART Chip

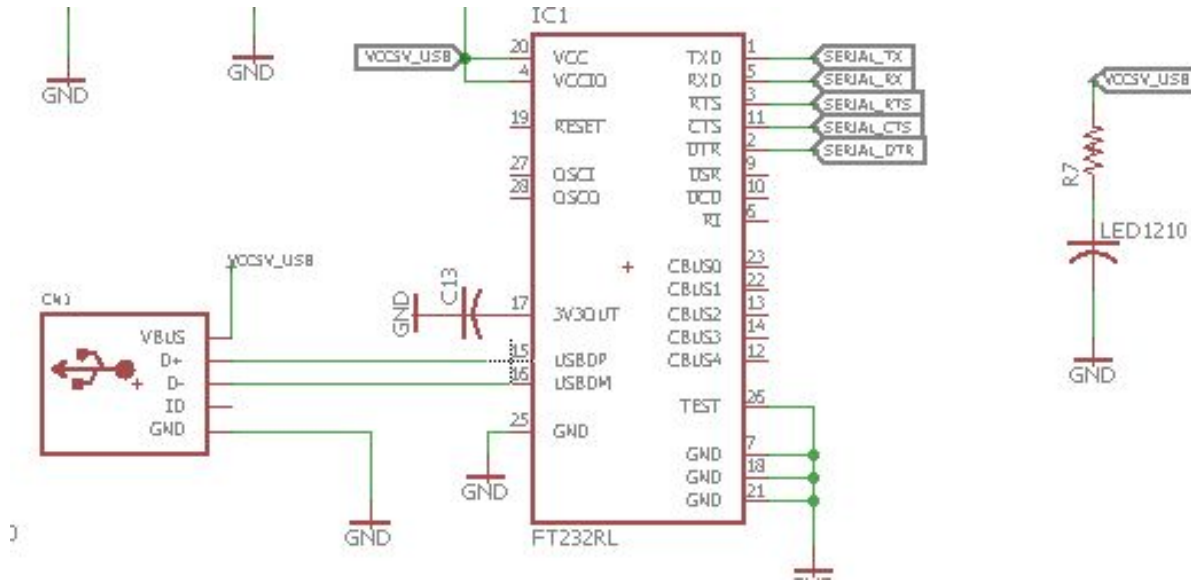

Allows for communication between the Intel NUC

Buffer Line Driver

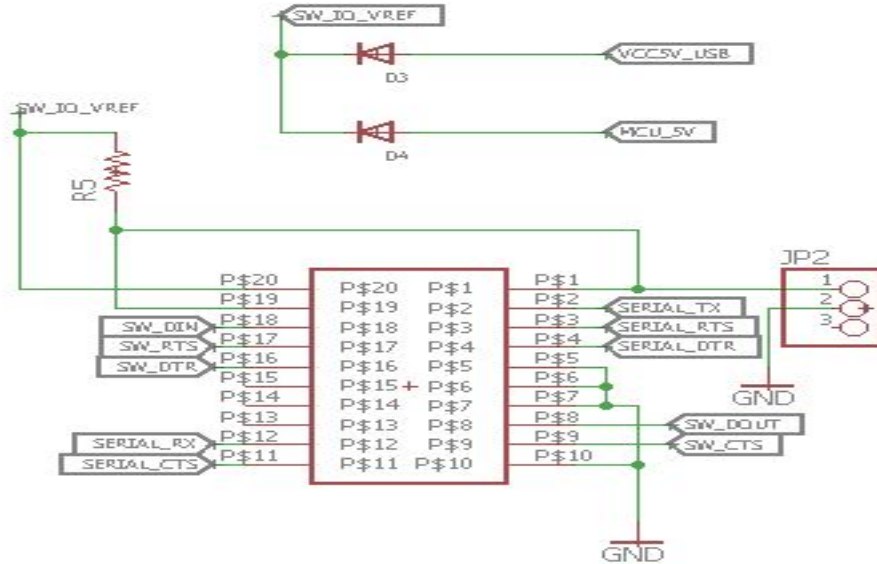

Buffer for data to be sent over the network

Skywire Chip

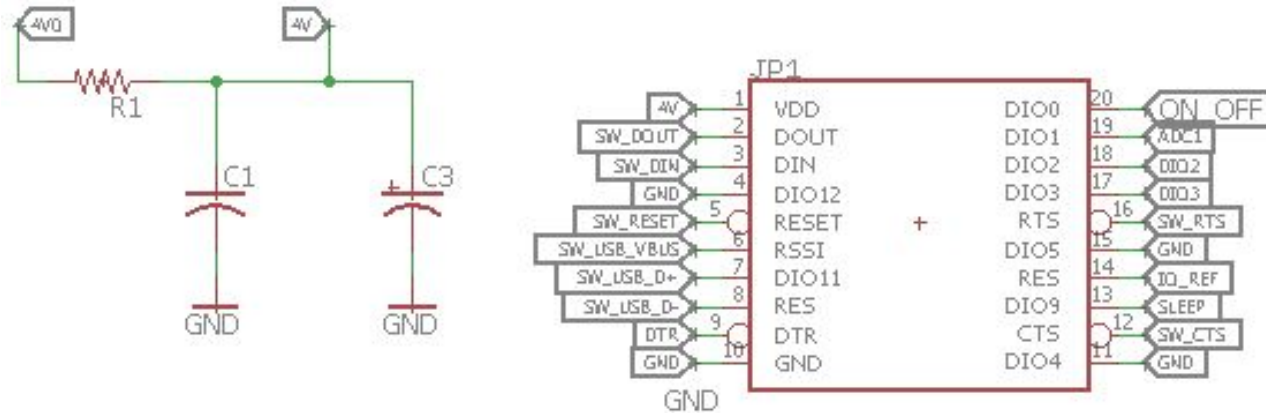

Skywire Chip allows for access to the Verizon network

Test Pin Headers

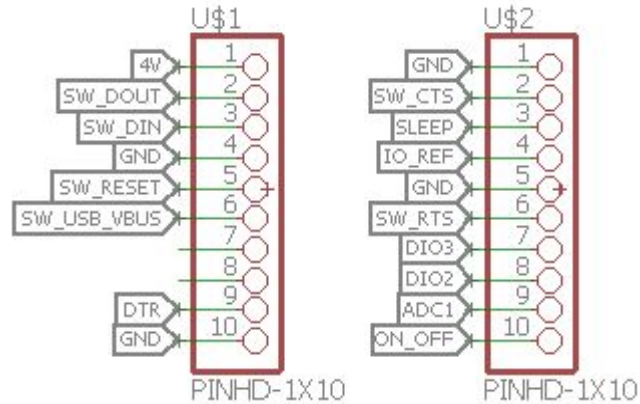

Test pin headers for proper outputs

PCB Layout

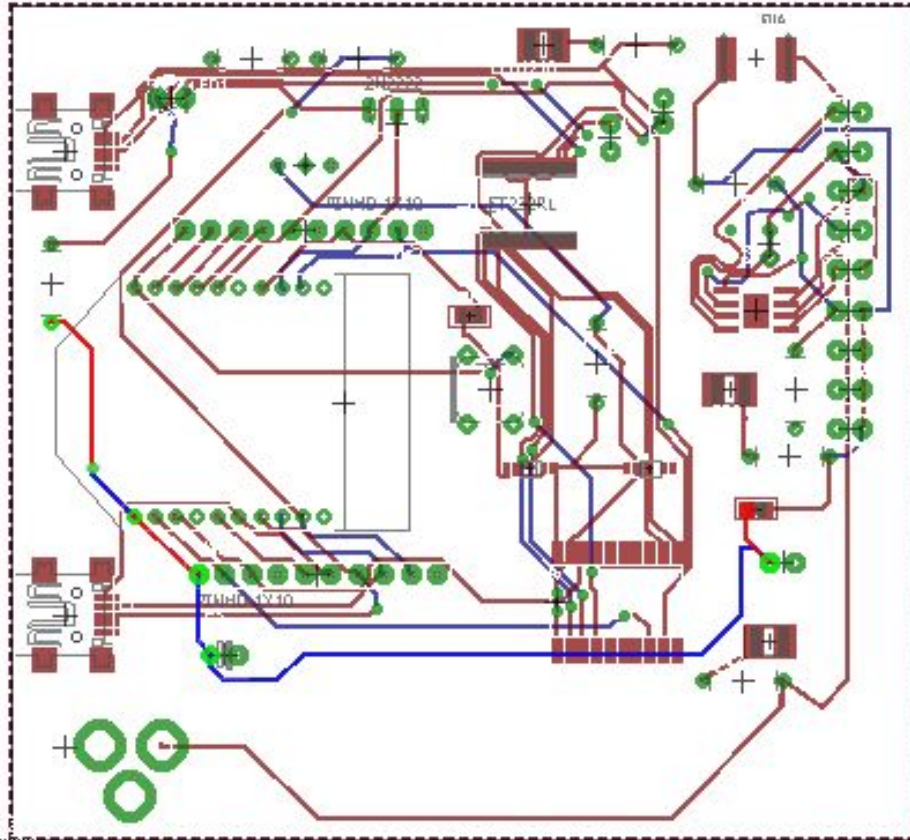

Up Next

- ▶ System Overview
- ▶ Specific Part Information
- ▶ PCB Design
- ▶ **Mobile Application**
- ▶ Software and Hardware Testing
- ▶ Budget / Difficulties

Mobile Application



QwikStats

KerbySoft Sports

★★★★★ 2

Everyone

This app is compatible with all of your devices.

Installed



Keep stats for youth and High School football games with ease! This is for use by the QwikCut team of shooters for all youth football. Many more features and improvements to come.

- ▶ Will be available for Android devices
- ▶ App is on the Google Play Store
- ▶ Acts as a remote control for the QwikBox

Mobile Application Flow

User opens app
and logs in

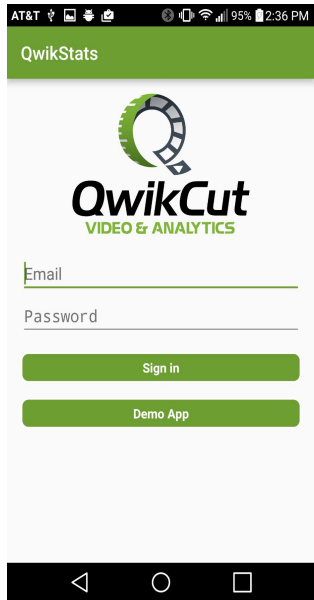

User selects
"QwikBox Control"

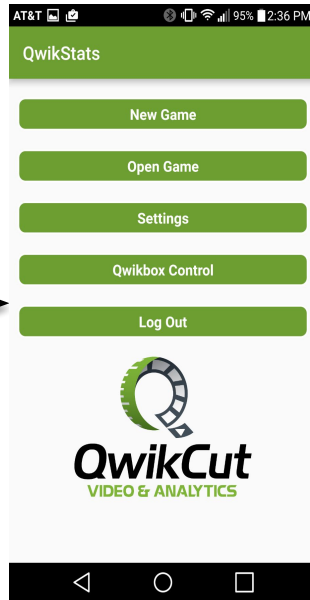

User has option to
create new game or
open a past game

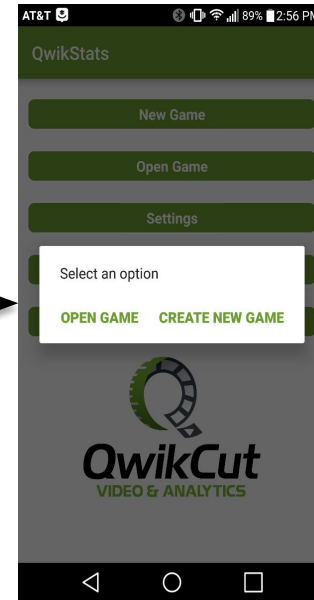

Mobile Application Flow (cont.)



Python Flask RESTful API

- ▶ A python flask RESTful API was developed and runs on the NUC from boot
- ▶ Accessible from a localhost port
- ▶ Interacts with mobile application to start and stop each clip
- ▶ Capture begins by running FFMPEG script
- ▶ Capture ends with a script that safely ends the FFMPEG process
- ▶ API also supports gathering of play information from the mobile app
- ▶ Uses an authentication key so only users of the mobile app can access it

Port Forwarding

- ▶ By itself, the API is only accessible to devices on the same network
- ▶ The user of the device will almost never be on the same network as the QwikBox
- ▶ Port forwarding is needed to provide access to the API from a public domain
- ▶ nGrok was used to forward a specific domain to the localhost port
- ▶ A script that starts the service runs on boot
- ▶ Users of the app can control the Qwikbox from anywhere in the world

Streaming

- ▶ The input stream will be captured using software package FFMPEG
- ▶ FFMPEG is used for the necessary video encoding
- ▶ The 'start_capture' script sets the correct resolution (1280x1080), frame rate (30 fps) for FFMPEG
- ▶ Audio is also captured by FFMPEG and synced with the video in real time

Up Next

- ▶ System Overview
- ▶ Specific Part Information
- ▶ PCB Design
- ▶ Mobile Application
- ▶ **Software and Hardware Testing**
- ▶ Budget / Difficulties

Software and Hardware Testing

- ▶ The Qwikbox has been tested by our sponsor by using it to record 5 different semi-professional football games
- ▶ Bugs fixes and improvements were implemented between tests to maximize the usability of the device
- ▶ The system was able to withstand outside temperatures and lasted the entire length of the 5 games



Up Next

- ▶ System Overview
- ▶ Specific Part Information
- ▶ PCB Design
- ▶ Mobile Application
- ▶ Software and Hardware Testing
- ▶ **Budget / Difficulties**

Budget

- ▶ \$1000 total project budget

Description	Quantity	Cost (\$)
PCB containing wireless communications (4G LTE / 5G)	1	316
HDMI to USB Capture Device	1	140
Intel NUC barebones	1	350
Battery Source	1	52
RAM	1	32
SSD Storage Device	1	91
Total		981

Difficulties

- ▶ Working with computer science team
- ▶ PCB integration with modem and Verizon network
- ▶ Amazon remote server communications
- ▶ Finding a perfect balance for the FFMPEG capture configuration
- ▶ Ensuring a quick encoding and upload time
- ▶ Working to fix various bugs

Thank you!

Any questions?

Created by:

Jonathan Kerbelis
Eric Downey
Harold Frech

Computer Engineering
Computer Engineering
Electrical Engineering