

# Smart Home Blackout Shades

## Senior Design I

Fall 2017

Sponsor: Jetsons Living



Group Number: 2

**Stephen Fryer** – *CpE*

**Brian Mora** – *EE*

**Priyank Patel** – *CpE*

**John Rossi** – *EE*

## TABLE OF CONTENTS

<b>List of Figures</b> .....	<b>i</b>
<b>List of Tables</b> .....	<b>iii</b>
<b>1.0 Executive Summary</b> .....	<b>1</b>
<b>2.0 Introduction</b> .....	<b>2</b>
2.1 Motivation .....	2
2.2 Goals and Objectives.....	3
2.3 Requirement Specifications.....	4
2.3.1 Market Requirements.....	4
2.3.2 Engineering Requirements .....	4
2.4 House of Quality Analysis.....	6
<b>3.0 Research</b> .....	<b>9</b>
3.1 Existing Products and Concepts .....	9
3.1.1 Smart Home Window Shades .....	9
3.1.1.1 Lutron Serena® Shades .....	9
3.1.1.2 Pella Insynctive® Blinds and Shades .....	10
3.1.1.3 Somfy MyLink Smart Window Shades .....	10
3.1.2 Similar Senior Design Projects .....	11
3.2 Relevant Technologies .....	13
3.2.1 AC-DC Converters .....	13
3.2.2 Batteries .....	16
3.2.2.1 Lithium-Ion Batteries.....	16
3.2.3 Photovoltaics .....	18
3.2.3.1 Solar Cells.....	18
3.2.3.2 Maximum Power Point Tracking .....	19
3.2.4 Voltage Regulators.....	20
3.2.5 Motors and Control.....	21
3.2.5.1 Brushed DC Motors .....	22
3.2.5.2 Brushless DC Motors.....	22
3.2.5.3 Motor Sensor Feedback .....	23
3.2.5.4 Driving a DC Motor .....	24
3.2.6 Motion Detection .....	26
3.2.7 IR Remote Control .....	27

3.2.8	Microcontrollers .....	27
3.2.8.1	Microcontroller Architecture .....	28
3.2.8.2	Microcontroller Communication .....	28
3.2.9	LEDs .....	31
3.2.10	Wireless Technologies .....	33
3.2.10.1	Wi-Fi .....	33
3.2.10.2	Bluetooth .....	36
3.2.10.3	Zigbee .....	38
3.2.10.4	Z-Wave .....	41
3.2.10.5	Comparison of WiFi and Bluetooth .....	42
3.2.11	Server and Client .....	43
3.2.11.1	Node.js .....	43
3.2.11.2	Angular.js .....	43
3.2.12	Application Development .....	44
3.2.12.1	Web Applications .....	44
3.2.12.2	Native Applications .....	44
3.2.12.3	Comparing Native and Web Applications .....	45
3.2.13	Amazon Echo .....	45
3.2.13.1	Adding Custom Skills to Amazon Echo .....	45
3.2.14	Software IDEs .....	48
3.2.14.1	Code Composer Studio .....	48
3.2.14.2	Arduino IDE .....	48
3.2.14.3	Eclipse .....	50
3.2.14.4	Visual Studio .....	50
3.2.14.5	Atmel Studio 7 .....	51
3.3	Strategic Components and Parts Selection .....	51
3.3.1	AC-DC Converter .....	52
3.3.2	Batteries .....	54
3.3.3	PV Panel(s) .....	56
3.3.4	Voltage Regulators .....	57
3.3.5	Motor .....	58
3.3.6	Motor Driver .....	59
3.3.7	IR Remote Control .....	61
3.3.8	PIR Motion Detector and Lens .....	63
3.3.8.1	Motion Detector .....	63
3.3.8.2	Fresnel Lens .....	64

3.3.9	Microcontroller/Wi-Fi Chip .....	65
3.3.10	LEDs .....	66
3.3.11	Shade Material .....	67
3.3.12	Web-Application/Bootstrap .....	68
3.3.13	Server Selection .....	68
3.4	Possible Designs and Related Diagrams .....	69
3.4.1	Initial Design Attempts .....	69
3.4.2	Pinout .....	71
3.4.3	Hardware Block Diagram .....	72
3.4.4	Software Diagrams .....	74
3.4.4.1	Web-Application Diagram .....	75
3.4.4.2	Amazon Echo Diagram .....	76
3.4.4.3	IR Remote Diagram .....	76
3.4.5	Code Flow Chart .....	77
3.5	Parts Selection Summary .....	78
<b>4.0</b>	<b>Design Constraints and Related Standards .....</b>	<b>78</b>
4.1	Related Standards .....	78
4.2	Design Impact of Standards .....	79
4.3	Realistic Design Constraints .....	80
4.3.1	Functionality Constraint .....	80
4.3.2	Economic Constraints .....	81
4.3.3	Time Constraints .....	81
4.3.4	Environmental/Manufacturability Constraints .....	82
4.4	Arduino Development Guidelines .....	83
4.4.1	Naming Conventions .....	83
4.4.2	Blank Line Standards .....	83
4.4.3	Function Formatting Standards .....	84
4.4.4	Comment Standards .....	84
4.4.5	Conditional Statement Standards .....	85
4.4.6	Miscellaneous Standards .....	85
<b>5.0</b>	<b>Project Design .....</b>	<b>86</b>
5.1	Hardware Design .....	86

5.1.1	Power System .....	86
5.1.2	Main Control System.....	87
5.1.3	PIR Board .....	89
5.1.4	IR Remote Board .....	92
5.1.5	PCB Design Overview .....	93
5.1.6	PCB Vendors and Assembly .....	93
5.1.6.1	ExpressPCB.....	94
5.1.6.2	Advanced Circuits .....	94
5.1.6.3	Elecrow.....	95
5.1.6.4	OSH Park .....	95
5.1.6.5	PCB Vendor Conclusion.....	96
5.2	Software Design.....	96
<b>6.0</b>	<b>Mechanical System .....</b>	<b>100</b>
6.1	Motor Shaft and Mounting Brackets .....	100
6.2	PCB Standoffs and Part Placement .....	101
6.3	System Enclosure .....	102
<b>7.0</b>	<b>Testing .....</b>	<b>104</b>
7.1	Power System Testing.....	104
7.2	Motor Testing .....	105
7.3	LED Testing .....	107
7.4	Motion Detector Testing .....	108
7.5	IR Remote Control Testing.....	110
7.6	Full Hardware Prototype.....	112
<b>8.0</b>	<b>Administrative Content .....</b>	<b>114</b>
8.1	Project Milestone Discussion .....	114
8.2	Budget and Finance Discussion.....	119
8.2.1	Bill of Materials .....	119
8.2.1.1	Jetsons Living Blackout Shades – Wired (AC) .....	120
8.2.1.2	Jetson Living Blackout Shades – Wireless .....	121
8.3	Parts Acquisition .....	122
8.4	Project Roles .....	125
8.5	Looking Forward .....	127
<b>9.0</b>	<b>Project Summary and Conclusion .....</b>	<b>128</b>

<b>Appendix</b> .....	<b>i</b>
<b>Acknowledgments</b> .....	<b>i</b>
References .....	vii

## List of Figures

FIGURE 2.4.I HOUSE OF QUALITY .....	6
FIGURE 3.1.I SOLAR BLINDS [7].....	11
FIGURE 3.2.I UCC28740 WEBENCH® AC-DC CONVERTER SCHEMATIC [9] .....	14
FIGURE 3.2.II UCC2813 WEBENCH AC-DC CONVERTER SCHEMATIC [10] .....	15
FIGURE 3.2.III WEBENCH UCC28630 AC-DC CONVERTER SCHEMATIC [11] .....	16
FIGURE 3.2.IV BATTERY CHARGING STAGE [12] (COURTESY OF CADEX ELECTRONICS) .....	17
FIGURE 3.2.V DIAGRAM OF A SIMPLE DC ELECTRIC MOTOR [18] (PERMISSION REQUESTED).....	22
FIGURE 3.2.VI OPTICAL ENCODER [19] (PERMISSION REQUESTED).....	23
FIGURE 3.2.VII HALL EFFECT ENCODER [19] (PERMISSION REQUESTED).....	24
FIGURE 3.2.VIII ONE DIRECTIONAL MOTOR DRIVE CIRCUIT [19] (PERMISSION REQUESTED).....	24
FIGURE 3.2.IX H-BRIDGE MOTOR DRIVER SCHEMATIC [19] (PERMISSION REQUESTED).....	25
FIGURE 3.2.X FRESNEL LENS (PERMISSION REQUESTED) .....	26
FIGURE 3.2.XI. TYPICAL IR SENSOR SPECTRA [26] (COURTESY OF LADY ADA ADAFRUIT USER) .....	27
FIGURE 3.2.XII HTTP FLOWCHART (PERMISSION REQUESTED) .....	30
FIGURE 3.2.XIII COMPARING LED OUTPUT (PERMISSION REQUESTED).....	31
FIGURE 3.2.XIV EXAMPLE WLAN WITH WIRELESS ROUTER [136] (PERMISSION REQUESTED) .....	34
FIGURE 3.2.XV BR/EDFR SPECTRUM VS. LF SPECTRUM [137] (PERMISSION REQUESTED) .....	37
FIGURE 3.2.XVI ZIGBEE-SUPPORTED NETWORKS [138] (PERMISSION REQUESTED) .....	39
FIGURE 3.2.XVII AMAZON ALEXA SKILL DESIGN PROCESS [62] (PERMISSION REQUESTED) .....	46
FIGURE 3.2.XVIII AMAZON ECHO INTERACTION FLOW/WORKFLOW.....	47
FIGURE 3.3.I LED COLOR PALETTES [117] (PERMISSION REQUESTED) .....	66
FIGURE 3.4.I ROUGH DRAFT POWER SYSTEM SCHEMATIC.....	70
FIGURE 3.4.II ROUGH DRAFT IR REMOTE SCHEMATIC.....	71
FIGURE 3.4.III ESP12 PINOUT.....	72
FIGURE 3.4.IV HARDWARE BLOCK DIAGRAM.....	73
FIGURE 3.4.V SOFTWARE BLOCK DIAGRAM .....	74
FIGURE 3.4.VI WEB APPLICATION FUNCTIONALITIES .....	75
FIGURE 3.4.VII AMAZON ECHO FUNCTIONALITIES .....	76
FIGURE 3.4.VIII IR REMOTE FUNCTIONALITIES.....	77
FIGURE 3.4.IX CODE FLOWCHART .....	77
FIGURE 5.1.I INITIAL POWER SYSTEM SCHEMATIC .....	86
FIGURE 5.1.II INITIAL MAIN CONTROL SYSTEM SCHEMATIC .....	87
FIGURE 5.1.III INITIAL MAIN CONTROL SYSTEM BOARD LAYOUT .....	89
FIGURE 5.1.IV INITIAL PIR SCHEMATIC.....	90
FIGURE 5.1.V INITIAL PIR BOARD LAYOUT .....	91
FIGURE 5.1.VI INITIAL IR REMOTE SCHEMATIC .....	92
FIGURE 5.1.VII INITIAL IR REMOTE CONTROL BOARD LAYOUT.....	93
FIGURE 5.2.I USER-INTERFACE MOCK-UPS (MENU, REMOTE, LED).....	98
FIGURE 5.2.II USER-INTERFACE MOCK-UPS (AUTOMATION SETTINGS).....	99
FIGURE 6.1.I SYSTEM HOUSING .....	100
FIGURE 6.2.I ELECTRONICS PLACEMENT WITHIN SYSTEM HOUSING.....	101
FIGURE 6.2.II BOARD LOCATION WITHIN SYSTEM HOUSING .....	102
FIGURE 6.3.I INFRARED LOCATION ON SYSTEM HOUSING.....	103
FIGURE 7.1.I POWER SYSTEM TEST.....	104
FIGURE 7.2.I MOTOR SYSTEM TEST.....	105
FIGURE 7.2.II MOTOR ENCODER WAVEFORMS .....	106
FIGURE 7.3.I LED TEST .....	107

FIGURE 7.4.I MOTION DETECTOR TEST.....	108
FIGURE 7.4.II MOTION DETECTOR OUTPUT.....	109
FIGURE 7.5.I IR REMOTE TEST.....	110
FIGURE 7.5.II TRANSMITTED AND RECEIVED IR SIGNALS .....	111
FIGURE 7.6.I FULL HARDWARE PROTOTYPE .....	113
FIGURE 8.3.I ALL PARTS ACQUIRED.....	125

## List of Tables

TABLE 2.3.I REQUIREMENT SPECIFICATIONS .....	5
TABLE 3.2.I COMMON LITHIUM-ION SIZES .....	18
TABLE 3.2.II BRUSHLESS VS. BRUSHED DC MOTORS [20].....	23
TABLE 3.2.III LIGHTBULB LIFE TIME COMPARISON.....	33
TABLE 3.2.IV CLASS DEVICES' AND THEIR POWER AND RANGES .....	38
TABLE 3.2.V CREATING AN AMAZON ALEXA SKILL.....	47
TABLE 3.3.I TRANSFORMER COMPARISON [73], [74], [75] .....	52
TABLE 3.3.II. RECTIFIER DIODE COMPARISON [76], [77], [78].....	53
TABLE 3.3.III. BRIDGE RECTIFIER COMPARISON [79], [80], [81] [82].....	53
TABLE 3.3.IV FLYBACK CONTROLLER COMPARISON [83], [84], [85].....	54
TABLE 3.3.V BATTERY COMPARISON [86], [87].....	55
TABLE 3.3.VI SOLAR PANEL COMPARISON [88], [89], [90], [91].....	56
TABLE 3.3.VII. 12V VOLTAGE REGULATOR COMPARISON [92].....	57
TABLE 3.3.VIII. VOLTAGE REGULATOR COMPARISON [93], [94], [95], [96].....	58
TABLE 3.3.IX MOTOR COMPARISON [97], [98], [99].....	59
TABLE 3.3.X MOTOR DRIVER COMPARISON [100], [101], [102].....	60
TABLE 3.3.XI MICROCONTROLLER FOR IR REMOTE CONTROL COMPARISON, [103], [104], [105] .....	61
TABLE 3.3.XII IR LED COMPARISON [106], [107].....	62
TABLE 3.3.XIII IR RECEIVER COMPARISON [108], [109].....	62
TABLE 3.3.XIV PIR SENSOR COMPARISON [110], [111], [112].....	63
TABLE 3.3.XV LENS COMPARISON [113] .....	64
TABLE 3.3.XVI MICROCONTROLLER COMPARISON [114], [115], [116].....	65
TABLE 3.3.XVII LED COMPARISON [118], [119], [120].....	67
TABLE 8.2.I TENTATIVE PROJECT BUDGET .....	119
TABLE 8.2.II BILL OF MATERIALS .....	120
TABLE 8.2.III BILL OF MATERIALS (REMOTE).....	120
TABLE 8.2.IV BILL OF MATERIALS WITH PRODUCTION (WIRED).....	121
TABLE 8.2.V PRODUCTION BILL OF MATERIALS (WIRELESS).....	122
TABLE 8.3.I DIGIKEY PURCHASE.....	123
TABLE 8.3.II ADAFUIT PURCHASE .....	123
TABLE 8.3.III AMAZON PURCHASE .....	123
TABLE 8.3.IV ACTUAL COST VS PROJECTED COST.....	124

# 1.0 Executive Summary

Home automation simply put, is any technology that shifts domestic tasks away from humans. Technologies in home automation have existed for more than a hundred years with inventions such as the washing machine, but a new era of home automation is becoming possible with the help of the Internet of Things. The Internet of Things connects appliances, vehicles, sensors, and many other objects together by leveraging the powers of cloud computing and embedded processing. As with any technology, there are scenarios of varying levels of complexity. Applications can range from a simple internet connected switch, to an image processing security system. In either case, modern electronics allow for a solution. It is an exciting proposition that this technology can be so extensible. With such robust tools and diverse problems, the Internet of Things lends itself almost perfectly to home automation applications.

Now, with the ability to have virtually any object be internet-connected, the question shifts from “What can be automated,” to “what should be automated?” In the estimation of the authors of this document, an application should be able to achieve a useful, repetitive function that is easily applicable to a wide swath of households, without the need of undue interactions, while also being efficient. These requirements, while quite basic, yield a framework for determining an appropriate application. Additionally, the energy sustainability of the system is taken into significant consideration. Every ordinary house has windows, and most of those windows will be covered and uncovered regularly. Thus, an appropriate home automation application arises; a solar-powered automated Internet of Things window shades system. This proposed system, when designed carefully, should meet the needs of the home automation problem set forth in a manner that is simple at the user-level, while also being thoughtfully engineered to handle the more nuanced aspects of operation.

This document will serve as a comprehensive documentation of the processes of research, design, testing, and production for a smart home window shades system. This Internet of Things window shade will automate the window shading process. The smart home window shades system will be solar powered, while it will also provide means for traditional wired power. The system will comprise itself of several input modalities: a web application and a manual remote control. Having Several input modalities allows for interaction with the system in various states. In this case, remote and line-of-sight, respectively. This system will also accommodate various automatic modes of operation. Again, an emphasis is placed on allowing for various means, and settings, of operation. In addition, the system will also comprise an array of programmable LED lights. It should be noted that a great deal of emphasis is placed on allowing for as many types of interactions and operation as can be feasible. This flexibility of operation options should allow for a diverse group of user interactions in various home environments.

A plurality of sensors and ancillary electronic systems necessary will both be examined, and evaluated, to ultimately comprise an appropriate solution. A selection of these sensors will provide the data necessary to enable the automatic modes of operation previously mentioned.

# 2.0 Introduction

## 2.1 Motivation

The Motivation for this project is to enhance living conditions of any homeowner, who wishes to live more comfortable and more connected. These days, many homeowners typically already own smart home devices such as voice assistants (Amazon Echo and Google Home), smart lighting (Phillips Hue), smart switches (GE Z-Wave Wireless switches), video surveillance, smart thermostats (Nest), video door bells (Ring), etc. Our goal is to add integrated smart shades to their list. As smart home devices become more popular and much more advanced, we intend on creating a product for our sponsor company that can enter the market at the same level as many other devices.

The goal of our project is to develop a device that can automate the typical home owner's blackout shades. In other words, our developed device can control how much sun light gets into the house as per user's requests. The shades can be drawn all the way for a full blackout effect, or any distance in between for just the right amount of light, without any solar glare. The device will communicate through Wi-Fi, and will be able to be controlled from the user's smartphone, or by a dedicated IR remote. Also, we plan to integrate our smart shades with Amazon Echo, so, the user can verbally control their shades. Our intention is to integrate the device with the sponsor company's system, which will then be able to tie in the device to other smart home devices such as their all-in-one smart hub, Arden. Users can set a time to automatically have blinds open/close in specified areas. Also, users will be able to set a schedule based on motion in the room. Users can also turn on our installed LEDs, which can glow specific color on their blinds, to set the desired mood. The device will have the option to either run on battery power, or be wired directly to the homes 120V 60Hz AC mains. If running on battery, the batteries will be able to be charged with a solar panel on the inside of the window. Ideally, it will be able to completely sustain its battery for very long periods of time. Currently, smart shades or blinds already exist in the market for consumers individually. However, we intend on making our product much more cost effective than the current products available, and ultimately our product will be integrated with our sponsor company's existing smart home system, as well as security system.

Upon starting this project, our tasks can be categorized into a multitude of sub tasks. First, we need to do substantial amount of research in the area of battery power, as well as protection and charging, and PV panels, since our device will be powered from the energy collected from sun. Next, we need to research and develop an AC to DC conversion method for the wired power. Then we will need to determine what microcontroller we will use and how it will be connected to the internet. Next, we will research how to control the motor and LEDs, and how we will take in data from the motion sensor. Then we will do research in the area of IR communication, and begin to prototype an IR remote. The next task would then be to begin designing our full schematics and getting an idea of how our PCB(s) will be laid out. Next, we need to figure out how to set up an app/web page for

user interface, and also integrate the device with Amazon Echo for voice control. Last, we will explore how we will fully integrate the device in to our sponsor company's system.

## 2.2 Goals and Objectives

Our team of electrical and computer engineers, along with our sponsor, laid out some initial goals for our project. These goals and objectives are intended to further our knowledge and experience as engineers, and help push us to become a more well-rounded group of students. They are as follows:

- Create a product that can be recreated on a production scale. Since window coverings are usually a custom-made design for the user's window, our goal is to create a complete design that can be integrated into many different window sizes. Of course, while window size does vary, this can become a difficult task. After discussing with our sponsor, it was decided that our electronic and computer engineering design should be able to remain the same, while the mechanical design (housing and shades) will need to be able to be custom scaled, to accommodate many window sizes.
- Create a product that can be available at a relatively low market price. This means being priced lower than some, or most, of the competition. Our sponsor has said that it would be beneficial to be able to recreate the product for around \$300 or less. This is a target price and has been determined to have some room for error.
- Create an adaptable product. Our sponsor has mentioned that they would potentially like to have two versions of the product; wired and wireless. This would save in production costs, as each version will do away with a certain number of parts. While our project will incorporate both for more intensive design purposes, the idea of two versions will be explored later in this report when exploring production costs.
- Create a product that is easy to install. An end product that can be built up and then installed as only a few parts would be best. The battery powered version would obviously be a lot easier to install due to the fact that it is a stand-alone device. When you start to think about adding wired power, the install becomes much more complicated since you need to run a power wire to the window frame.
- Create a system that can send/receive commands over Wi-Fi. Our sponsor company's current smart home/security system achieves communication using Wi-Fi. Having this capability would make for the easiest transition and integration into their system.
- Create a system that can be voice controlled. Many of the products that our sponsor uses come with amazon echo or google home command capability built in. Also, our sponsors stand-alone devices have been integrated into amazon echo by creating custom commands. It is a goal to have our system able to be controlled over amazon echo to allow an even more seamless turnover to our sponsor company.
- Create a responsive web application. Our system can be controlled directly from our developed web application. This web application can be launched and used to connect to the shades via any device (including tablets, phones, and desktops/websites). In addition, we will be able to control the shades, LED lighting, and display the battery percentage all from the web application.

## **2.3 Requirement Specifications**

According to Pragmatic Marketing, IEEE states that the definition of requirement is a statement identifying a capability, physical characteristics, or quality factors that limits a product or problem in process for which solution will be pursued. Or perhaps, [1] another way to define requirements is a collection of engineering requirement and marketing requirements that product or system must meet. [2]

According to the Pragmatic Marketing, there are a couple of ways to evaluate your requirement. One method is usually popular in many established organizations is called SMART. S stands for Specific, M stands for Measurable, A stands for Achievable, R stands for Realistic, and lastly T stands for Time-Bound. A specific requirement specifies what is to be achieved. Measurable relates to providing any types of metrics that is used to determine objectives are being met or not. Achievable means that the requirement is not out of reach for the given design team. Realistic means requirement should be real enough to complete. Last but not least, time-bound explains that requirement is able to be completed in given amount of time.

### **2.3.1 Market Requirements**

According to the Pragmatic Marketing, understanding the market is the first step in creating innovative products. The collection of market requirements is many times refers as “body of market requirement documents”. Successful organization uses next five steps for developing innovative products. These five steps are listed as: find a problem, analyze it, design an innovative solution, code to the design, and lastly, test the result. [2]

The market requirements for our project are as follows:

1. Simpler User Interface: System should be easy to use.
2. Wireless Connectivity: System should be able to be connected without any wires and preferably connected via Wi-Fi.
3. Battery Life: System should have preferably extensive battery life.
4. Easy to Install: First-time install should be made easy.
5. Noise: System must not produce any loud and unnecessary noise.
6. Cost: production cost of the system should be minimized for the sake of commercialism.

### **2.3.2 Engineering Requirements**

Engineering requirements [1] are brief sentences that deals with a technical need of design. Each engineering requirement aims to satisfy the next four requirements. Engineering requirement should be abstract, needs to be verifiable, unambiguous, and lastly, traceable. Abstract means that engineering requirement should specify the system’s functionalities, and not the implementation. Verifiable relates to a way of measuring or presenting that requirement is met in the final system completion. Unambiguous is obvious, and basically states that requirement is a full statement, written clearly. Traceable means that it relates to marketing requirement. Every engineering requirement should meet the marketing requirement. Usability requirement tackles the ease of use of a system.

The engineering requirements for our project are listed in *Table 2.3 i* below.

*Table 2.3.i Requirement Specifications*

Marketing Requirement	Engineering Requirement	Justification
4	Ease of the Installing the Product (15 minutes).	First Time install of the product should take no longer than 15 minutes as per required by marking requirements and demands from the sponsors of this project.
4,1	Reaction Time (500 Milliseconds or less).	Reaction time from user to the System, time from user clicking a button in our web application to the action taking a place. Shades should respond no later than 500 Milliseconds.
3	Average Solar Panel Output Power (~6 watts)	The power output of the solar panel should be able to sustain the systems batteries for a very long period of time.
1, 5	Motion Detection Range (>3 meters).	The motion detector should be able to detect motion in an entire average sized room.
3	Power Consumption (< 10 watts).	Our System, window Shades, should operate within on average of 6 watts.
1	Dimensions (Window Width Between 2ft- 5ft).	Initially, our system, window shades will be built to operate on windows with dimension as described.
2	IR Receiver distance (> 15m).	Our dedicated physical remote receiver capabilities will enclose within 15 meters.
6	Cost (\$300 or less).	For sake of a budget, our project will be completed around no greater \$500. Our sponsor has requested that the product can be recreated at a cost of around \$300 or less.
1,2	Amazon Echo Skills (at least 3 or more)	Commands developed for users to control their window shades via voice using amazon Echo.

## Stretch Goals:

1. Shade Transparency: This feature can be installed in our existing product based on marketing requirement and realized needs of the customers.
2. Wired Charging of Batteries: This feature can be installed as an alternative for charging the battery, as opposed to implementing solar charging.
3. Length Programmability: System can be integrated with any size length of the windows at any location.
4. IR Remote LED Control: The user would be able to control the LED lighting from the IR remote.

## 2.4 House of Quality Analysis

The house of quality is a special tool that encompasses marketing, design, sales, and manufacturing. It distinguishes between and groups together what the client or customer wants and recognizes the significance of those wants. By correlating them, the main priorities and goals for the system's requirement are given and verified at the same time. [3] The House of Quality for the Smart Home Blackout Shades is given in *figure 2.4 i* below.

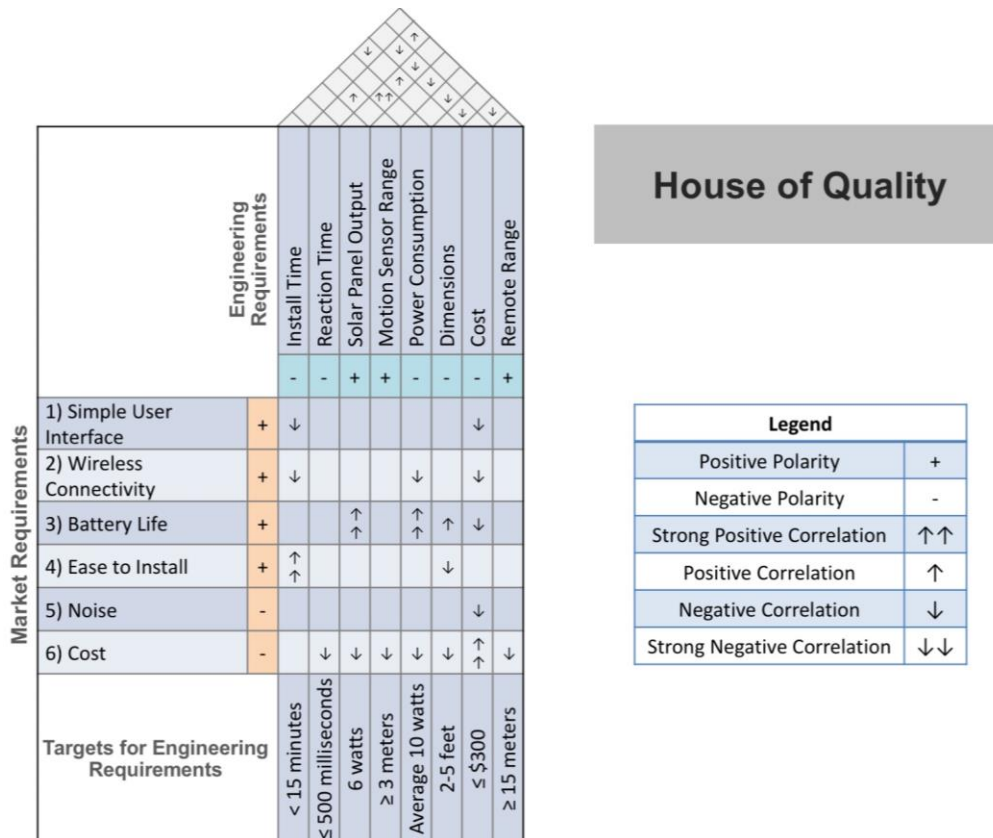

Figure 2.4.i House of Quality

The overall design of the app's interface is intended to be very simple for the user. The user's phone will be used as a possible remote. Being able to perform simple functions such as moving the shades up and down requires the interface to be simple as well. If the app was too complicated, the actual remote would be used and prioritized much more in comparison. However, having an app allows for more features to possibly be added and customized. Installing an app on a user's smart device shouldn't take longer than a few minutes to complete. While the app is downloading, the installation of the actual shades can be worked on, however, there will be some amount of time that will have to be used during the overall installation.

The wireless connectivity requirement covers how the shades communicate with the other devices it is paired with. Using a wire for the remote or to connect to the internet creates inconveniences in a time where many smart devices utilize wireless connectivity. With the shades connecting to the Amazon Echo, a remote, and any smart device, the wireless connectivity of each must not cause interferences.

Since the shades are going to utilize solar energy while having motion sensors, LEDs, and wireless connectivity, it is very important for the battery to be able to withstand normal operating conditions. While the shades will be able to receive power from an outlet, the ability to save energy by using the solar panels to charge the battery is very appealing. However, having a battery capable of recharging many times over is something that will definitely increase the overall cost of the shades. Having a battery capable of storing a large amount of energy can also increase the amount of power being consumed by the shades.

Making sure the shades are easy to install for the typical client is important because the shades have a few parts that must be configured. Taking measures to prevent issues arising during installation while having clear and concise instructions will help reduce the install time.

The noise of the motor that drives the shades up and down should hardly be noticeable as users wouldn't want to use the shades as much if the amount of noise created was too high. However, using a quiet motor will most likely have an effect on the overall cost of the shades.

While all of the market requirements are important to consider, cost is definitely one of the most important ones that must be considered. The idea of smart blackout shades can seem simple so consumers may not be willing to spend a large amount of money for this product. However, the engineering requirements ensure that the blackout shades will be worth the price.

Having an install time of less than 15 minutes ensures that the product will not be a hassle to put in the user's home. Making the shades able to respond to commands from any input within 500 milliseconds is important as many devices have a response time that is within this range as well. Having a larger time for the system to react could be easily noticed and disliked.

The motion sensor's range being around 3 meters is to guarantee that the shades can detect movement in any reasonable room. This could possibly effect the response time

of the system so careful consideration will have to be taken in the type of motion sensors used. Power consumption can greatly influence how much a user ends up spending in the long run so having 10 watts as the limit was deemed to be reasonable. The dimensions of the shades will range from 2-5 feet in order to have the ability to cover different types of windows with different lengths. However, having large dimensions can put strain on the motor requiring it to use more power.

The cost for the blackout shades is believed to be less than \$300. The use of solar panels, motion sensors, a motor, the shades, remote, hardware, and lights could possibly add up near this amount. However, the goal of keeping the cost low is still a very highly prioritized one. The quality of each part will play a major key in how much the product will cost. One quality being the range of the remote. This was made to be around 15 meters as it will most likely be easy to implement without effecting the cost too much.

# 3.0 Research

## 3.1 Existing Products and Concepts

As mentioned before, there are many different smart home technologies and products that can be controlled and communicate with one another in a variety of different ways. The most popular devices are usually plug-and-play such as smart thermostats, smart light bulbs, and smart speakers. These products require little installation and not a lot of background knowledge to operate. A simple user interface is a great bonus to have in a smart home device, and it is proven that products with a simple user interface, and easy integration market very well to your average consumer.

### 3.1.1 Smart Home Window Shades

#### 3.1.1.1 Lutron Serena® Shades

Lutron Electronics Co. specializes in energy saving, fully controllable devices for the home. They were founded in New York City in the 1950's, and started by creating the in-wall dimmer switch that we all know and love. The company has advanced the technology of lighting control while maintaining top market position by focusing on exceptional quality and design. [4] Their products are used in many residential applications, from small single-room apartments to large estates, including the White House and Windsor Castle. Aside from smart dimmer switches, Lutron offers smart window shades, in order to take control of not only electronic lights, but also natural, outdoor sunlight.

#### Specifications

- Battery or Wired Powered models. With 10 output, central power panel available.
- 3-5 Year battery life, requires several AA or D batteries, depending on the window size.
- Shade Width Range: 14.5in to 96in
- Shade Length Range: 12in to 96in
- Operating Voltage: 6-12 Volts DC
- Shade Speed: 1.8 in/sec
- Communicates using Lutron Clear Connect RF technology (FCC 15.231)

#### Advantages

- Industry leading battery performance.
- Can be integrated with Apple® HomeKit.
- Available with many different shade materials, each having different insulating power, to block out more sunlight and increase the homes energy efficiency.
- Can be controlled manually, over RF, and over IR.
- Very aesthetically pleasing.
- 8 Year Limited Warranty.

### Disadvantages

- Lots of complicated features and documentation. Primarily designed for installation at the contractor level.
- Light gap on either side of fabric ranging from 1/8 in to 3/4 in.
- Somewhat pricey: starting around \$350 on the low end.

### **3.1.1.2 Pella Insynctive® Blinds and Shades**

Pella Corporation, was founded in Pella, Iowa by the Kuyper family, who still owns and operates the company to this day. [5] Pella started by manufacturing rolling window screens, and has since developed into a multi-patent company with a variety of products. These products include windows, doors, window screens, security sensors, and smart home management solutions including their Insynctive® blinds and window shades.

Pella's Insynctive® blinds and shades are a between-the-glass design which creates for a non-obtrusive, sleek looking finish.

### Specifications

- Powered by a rechargeable lithium-ion battery pack. Can be charged via a solar panel on the exterior side of the unit (requiring approximately 3 hours of direct sunlight per day) or the Pella wall charger, which magnetically couples to a port on the battery pack. The typical battery life of the pack is ~3 years.
- Communicates at 433.92 MHz (Insynctive®)

### Advantages

- Slats of Blinds can be tilted to vary the amount of light/privacy in the room.
- In between glass panes, therefore less susceptible to damage.
- 5 Year warranty on blinds and shades. 2 Year warranty on bridge (hub).

### Disadvantages

- Extremely expensive: Blinds and Shades starting at \$1049.
- Very few features for such a cost.
- Requires bridge/hub for wireless communication.

### **3.1.1.3 Somfy MyLink Smart Window Shades**

Somfy Systems started in France as a parts manufacturer for Swiss watches. Somfy is an acronym, it stands for **Societe d'Outillage Mecanique du Faucigny** which translates to Mechanical Tooling Company of Faucigny. [6] They entered the automation industry after a local awning and shutter company needed a way to power their product, and Somfy was able to deliver a working prototype. Nowadays, Somfy creates numerous products for home and workplace automation, including blinds and shades, curtains, projector screens, shutters, exterior screens, awnings, pergolas, and motors and control systems. The Somfy MyLink smart motoros come in a large variety of different configurations to fit each and every individual need.

## Specifications

- Power options: 12VDC, 24VDC, 120V/60Hz
- Communicates at 433.32 MHz
- Available with wired communication as well as RF
- Programmable Speed 6-30 rpm
- Index Protection: IP 30, IP 44
- Minimum Window Width: 18.5in
- Noise Level: 20dBA – 44dBA

## Advantages

- Lowest cost: Starting at \$299.
- Full 5 Year Warranty.
- Many Different configurations with different power options.
- Very Flexible: can be used in a variety of residential and commercial applications

## Disadvantages

- Much more complicated to install.
- Requires extra parts in order to mount and to control.

### **3.1.2 Similar Senior Design Projects**

Looking at similar senior design projects can help our research in many ways. We are able to see what past projects have done for any part of their design. This allows us to create improvements, find possible problems we may have overlooked, and give us new ideas or solutions.

One similar project from senior design at UCF was called Solar Blinds. A picture of their prototype is provided in *figure 3.1 i*.



*Figure 3.1.i Solar Blinds [7]*

This project was done in 2015 and has very similar aspects to what our project plans to do. Both projects use solar energy and have similar goals. Solar Blinds wanted to have high energy efficiency, easy installation, be remote controllable, have a self-sustaining operation, be relatively low-cost, and be lightweight. Energy efficiency, remote controllable, relatively low-cost, and lightweight are key shared goals between our project and theirs. [7]

Solar Blinds had their solar panels connected to a charge controller that controlled the battery and went to the PCB and MCU. The MCU talked to the mobile device, handled the LCD display, USB charger, and motor. Since this project dealt with blinds, they considered using 2 different kinds of motors. 1 motor to handle horizontal slats for horizontal blinds and the other motor was for vertical slats on vertical blinds. Our project plans on using only 1 motor to roll the shades up and down. Their design also ended up using a motor to roll up their blinds. This allowed them to save power, have one motor for any window, and have less complex wiring. [7]

For their solar cells, they combined a thin film module and monocrystalline module which was hooked up to a 60W battery. The total power produced by the combined module was 36.96W. The USB charger was only used for charging the phone since they didn't use the data lines. Their total power consumption was around 20.5W. Our project is planning to only use 10W in total. [7]

Since they found the Android operating system to be the most popular compared to iPhone and Windows, the app they developed was for Androids. [7] Our project will be developing the app for Androids as well. Similarly to what we plan on doing, the app was able to control their blinds by going up, down, and stopping. Their app also showed information about the weather, battery, and was able to sync the phone and the RFID tag. The battery info displayed how much longer it would take to fully recharge the battery at the current rate and how long it would take based on the forecast. Many of these features are things our app could include, but many of them do not seem practical to add to the design. For example, the weather could be seen by looking out the window the shades are attached to and the information about how long until the battery was going to fully recharge does not appear to be that useful for a typical user.

Issues that the Solar Blinds group had that our group can plan to avoid were: transferring energy from the thin film solar module to the battery, not having enough space in the enclosure for electronics, programming on the PCB, and exchanging data over Bluetooth. By looking into these, our group can better prepare for transferring energy from the solar panel to our battery and making sure we have enough space for our electronics compartment. Our group plans on using Wi-Fi to exchange data, so the issue with exchanging data using Bluetooth shouldn't be an issue. [7]

Looking at what this group did specifically for some of the hardware aspects of their project, the reasons behind their design can be evaluated for the possible use in our project. For their charging circuit, they went with a Gena Sun Gv-5 65W 5A Solar Charge Controller with MPPT which saved them the struggle of designing a circuit on their own. Using a prebuilt battery charger could be something our group will consider if time does become a constraint. They used a CC2640 microprocessor due to the sufficient amount

of I/O pins it had as well as its support for Bluetooth. Their LCD display and motor were then connected to the MCU. Using a crystal, the temperature was read and displayed on the LCD. To turn the motor either clockwise or counterclockwise, the LtSpice motor required a high voltage from the MCU on one of its I/O pins. The specific parts they used and similar parts can be further evaluated and compared in the later section on parts selections. [7]

## **3.2 Relevant Technologies**

In this section, Section 3.2, our group will outline the research done on the specific technologies that will make up our system. This will contain a general overview of each technology, including how they function, and how they are important to our project. It is not the intention of this section to choose specific components, or implementations. These considerations will be later explored in Section 3.3. As such, this section should be solely treated as broad, brief explorations into the various technology spaces that are relevant to this project. It is the intention of this section to provide the reader with the various possible approaches to solving the relevant project's main problems.

### **3.2.1 AC-DC Converters**

The AC-DC converter is an essential electrical device. There are various conversion scenarios, but for this overview only a relevant scenario will be explored. A common scenario, that is relevant to this project, is using the 120-volt 60 Hz alternating current waveform from household electrical outlets to power electrical systems that require stepped-down direct current waveforms for power, say 24-volt DC. This is necessary because a majority of electronics require low voltage DC supplies for operation. This process of converting AC to DC happens in several distinct steps. The first step in this conversion is the transformer stage, which will be used to step down the high voltage AC waveform to a lower voltage AC waveform. The next step, rectification, converts this stepped down AC waveform to a DC waveform. The last step in this conversion is filtering this rectified DC waveform to a smoother DC waveform with ripples. Once this AC-DC conversion takes place, this DC waveform with ripples can now be put through a voltage regulator to finally produce a useful regulated DC waveform. This is a very broad, basic, overview of the AC-DC conversion, but for the purposes of this section that is sufficient. What is of more importance in this, Section 3.2.1, is an overview of the presently relevant AC-DC technologies.

As the basics of AC-DC conversion are well known to one skilled in the art, the focus of this section will explore various, more advanced, topologies for AC-DC conversion. This way, the focus of this section can be more aptly placed in current technologies, rather than in another retelling of the fundamentals. Texas Instrument's WEBENCH® design center is a helpful design tool that will provide reference circuits for various applications. In this section WEBENCH design center will be used to generate various designs for an AC-DC converter that takes a primary input of 120-volt, and an output secondary of 12-volt at 3-amps. A point of note, all of the designs to be presented make use of flyback converters. That is, a buck-boost topology that uses the inductor simultaneously as a transformer to affect the voltage, while also providing galvanic isolation. While the designs may seem similar because they employ this single flyback converter scheme, the designs

implement this technology in appreciably different ways. These differences in implementation will be the subject of the remainder of Section 3.2.1. As such, several of these designs will now be explored. [8]

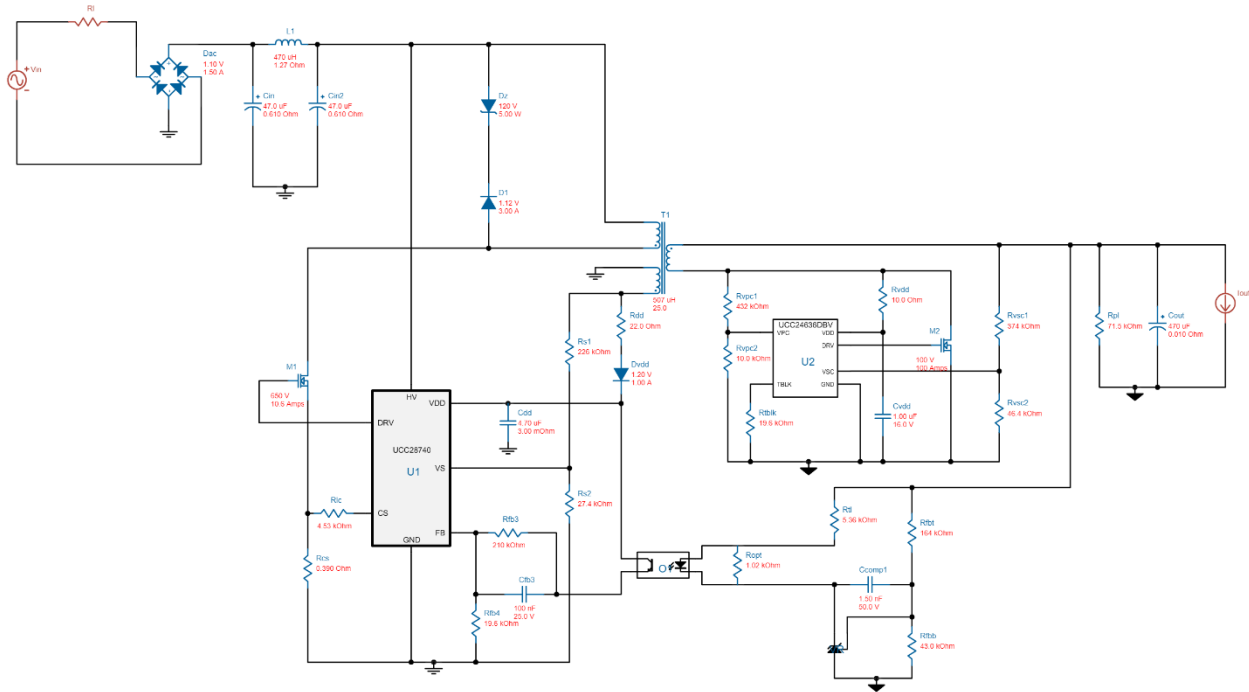

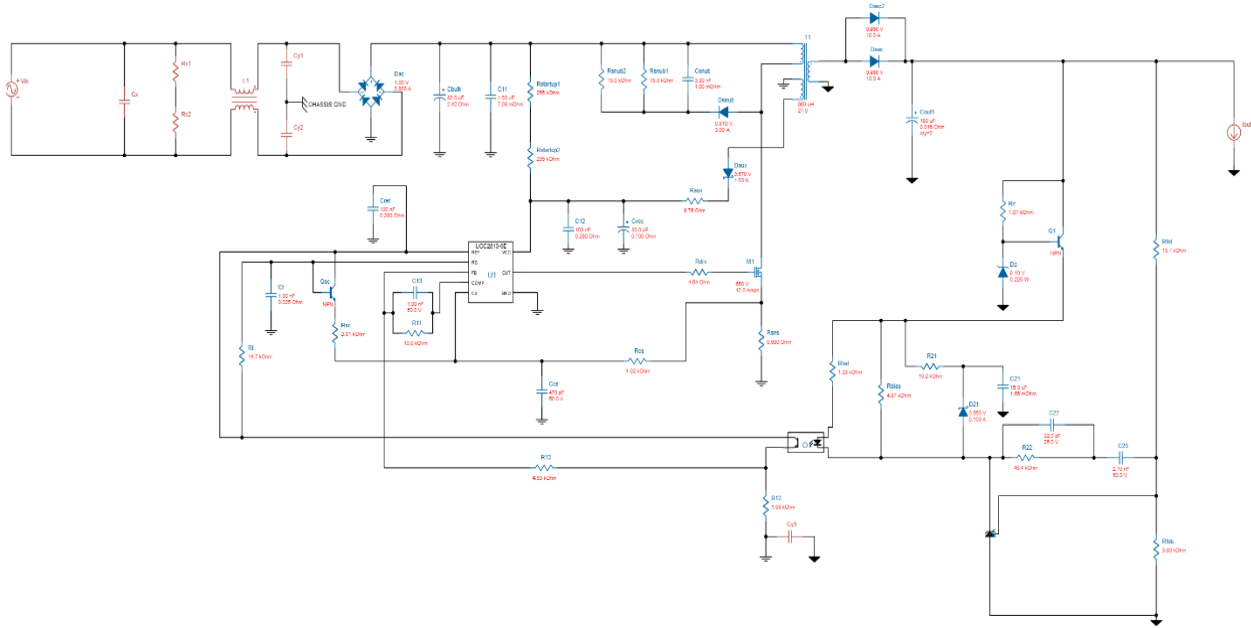

Figure 3.2.ii UCC2813 WEBENCH AC-DC Converter Schematic [10]  
(Permission Requested)

The next schematic to be explored, shown in *figure 3.2 ii*, is another WEBENCH generated design. This design makes use of the UCC2813, a low power economy BiCMOS current mode PWM, to control the conversion process. This approach also requires the use of an optocoupled feedback from the secondary side, but does not require another chip for regulation on the secondary side. The UCC2813 also makes use of current sensing, and feedback from the secondary. This design's efficiency is 88.46%, that is higher than the first design examined. This design requires 49 components, which is also greater than the first design. While there are more parts, and a higher efficiency, this design's footprint is actually smaller at 2125 square millimeters. The component cost is calculated to be \$11.24. Compared to the first design presented, this design has a higher efficiency, but at the cost of more complexity.

The next design to be examined is another WEBENCH generated one, shown in *figure 3.2 iii*. Once again, this design makes use of a flyback controller. In this case, the UCC28630, a high power flyback controller with primary-side regulation and peak power mode. A major difference in this design from the two prior designs that this one does all of the output sensing on the primary. That is, this design does not require an optocoupler, or any secondary side sensing at all. This is achieved through magnetic input and output sensing on the transformer's bias winding. This allows for its smaller footprint of 1911 square millimeters. Additionally, this design is less complex with only 27 components. All while maintaining an efficiency of 83.44%.



(LiNiCoAlO<sub>2</sub>), and Lithium Titanate (Li<sub>4</sub>Ti<sub>5</sub>O<sub>12</sub>). These different compounds all give the battery different characteristics as far as charge rate, discharge rate, capacity, nominal voltage, and life cycles. As a whole, lithium-ions can be divided into two main groups: Lithium-ion, and Lithium-ion Polymer. Lithium-ion batteries are usually cylindrical, and have a hard shell or casing. Lithium-ion polymer however, have a much softer casing, which is easier to damage. They are often used in applications where there is a need for small size and large capacity, such as cell phones and laptops. Most lithium-ion batteries have a nominal voltage of 3.7V per cell. The cell can vary from 4.2V fully charged, all the way down to 3.0V when fully discharged. Charging or discharging beyond these upper and lower bounds can lead to damage to the cell, potentially ending in combustion. That being said, it is extremely important that lithium-ion cells are handled properly which extreme care. Most lithium-ion battery packs come with some sort of protection circuit pre-installed. They typically use one or more IC's that allow voltage and current cutoff at the specific parameters defined by the battery manufacturer. Lithium-ion charging typically occurs in three stages; constant current, constant voltage, and an optional topping charge. First, a constant charge current is applied to the cell which is listed in the battery's datasheet. Then, when the voltage peaks, typically around 4.2V, the current begins to slowly drop off. Full charge is typically reached when the current decreases to between 3 and 5 percent of the Ah rating. [12]

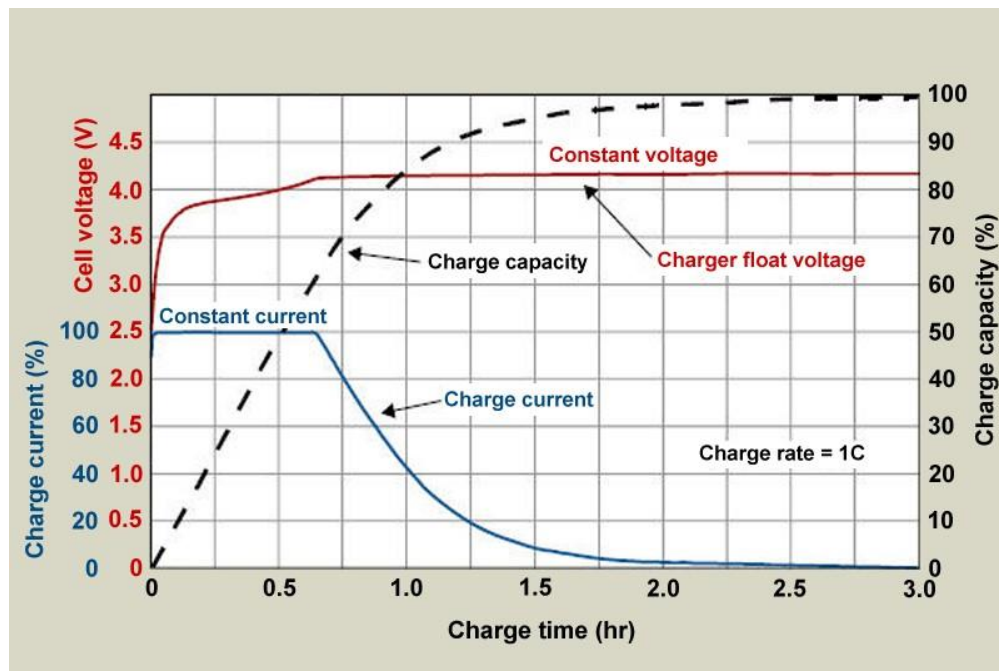

Figure 3.2.iv Battery Charging Stage [12] (Courtesy of Cadex Electronics)

In figure 3.2 iv above, the constant current, and constant voltage phases are easily identifiable. Also notice that the charge rate is equal to 1C. C is a measure of the batteries capability, and is equal to the Amp-Hour capacity of the battery, divided by one hour. For example, a 3000mAh battery is 3A. The higher the C, the more current you can pull from a battery without damaging it.

Lithium-ion batteries come in many sizes. For example, the 18650 lithium-ion battery is very commonly used in rechargeable applications. It is used in laptops, LED flashlights, electronic cigarettes, and in many Tesla Motors® vehicles. *table 3.2 i* details a few common sizes, their capacities, dimensions, and uses below.

*Table 3.2.i Common Lithium-Ion Sizes*

<b>Size</b>	<b>Capacity</b>	<b>Dimensions (Diameter x Length)</b>	<b>Uses</b>
10440	340 mAh	10mm x 44mm	Same size as AAA cell
14500	700-800 mAh	14mm x 53mm	Same size as AA cell – Used in some LED flashlights
15270	450-600 mAh	15mm x 27mm	Same size as CR2 cell – Can be used as a substitute
17500	1100 mAh	17.3mm x 50mm	Same size as A cell
18650	2200-3400 mAh	18.6mm x 65.2mm	Used in laptop batteries, as well as LED flashlights and Tesla vehicles
25500	3300 mAh	24.3mm x 49.2mm	About the same size as a C cell
32600	3000-6000 mAh	32mm x 61.9mm	About the same size as a D cell

### **3.2.3 Photovoltaics**

Photovoltaics refer to the process of converting the energy from light into electrical energy. The fundamental concept behind this technology is the photovoltaic effect. The basic premise of the photovoltaic effect is that when a photon of a certain energy is absorbed by a certain material an electron will be ejected. Of course, this process is much more complicated, but for the purposes of this overview this basic idea will suffice. There are several important concepts in understanding photovoltaics. The construction of solar cells provides insight into the physical reality of photovoltaics. The other concept presented is that of maximum power point tracking, which is a concept that is important in practical photovoltaics. [13]

#### **3.2.3.1 Solar Cells**

The most common type of solar cell is the large area P-N junction. In much the same manner as traditional P-N junctions, silicon is doped into p-type and n-type regions. At the junction of these regions diffusion takes place, which results in an electric field, and in turn a depletion region. That is, a region that is without mobile charge carriers. When an electron-hole pair is created within a neutral region, diffusion will take place and if the charge carrier reaches the depletion region it will be swept across by the electric field to the other region. This results in a current. It should also be noted that the charge carrier diffusion length should be much larger than the depletion region such that charge carriers are much more likely to reach the depletion region, and thus more likely to be swept across. [14]

### 3.2.3.2 Maximum Power Point Tracking

Now that a basic understanding of solar cells has been explored, an explanation of some practical aspects of solar cell operation are in order. Specifically, what is the solar cell's output, and how can this output be maximized. First, a look at the output of a solar cell.

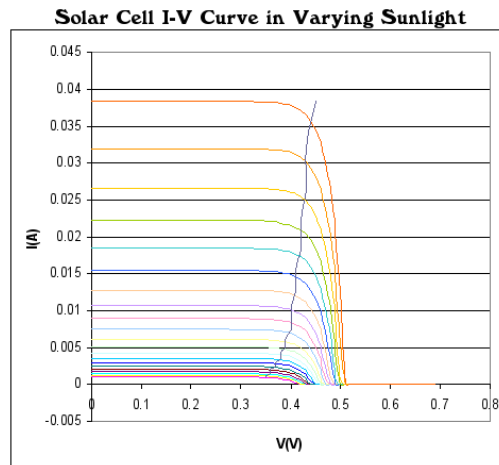

Figure 3.2 v: Solar Cell I-V Curves (courtesy of ZyMOS Wikipedia user)

The output of a solar cell can be shown with I-V curves. As shown in *Figure 3.2.3.i*, solar cells generally operate at a constant current if the solar cell is running below its open circuit voltage. The instantaneous specific I-V curve depends on environmental conditions such as radiance and temperature. It should be noted that the goal in solar cell operation is to extract the maximum amount of power. Since these environmental conditions are constantly changing, so is the solar cell's I-V curve, and thus a problem arises. With every specific I-V curve there exists only a single point of maximum power, the maximum power point. This maximum power point consists of a single pair of voltage and current values. Recall that power is the product of voltage and current, and that resistance is the quotient of voltage divided by current. Since there exists only a single unique pair of voltage and current values in an I-V curve at the maximum power point, there exists only a single value of impedance at this maximum power point, also called the characteristic impedance. When the load impedance has a value of the characteristic impedance, the solar cell is operating at its maximum power point. This is the fundamental idea of maximum power point tracking; to adjust the load impedance to match the characteristic impedance of the solar cell in real time. In maximum power point tracking there are various techniques. Three techniques will be explored: Perturb and observe, incremental conductance, and constant voltage. [15]

In the perturb and observe method, the voltage is increased a very small amount, and then the power is measured. If the measured power increased, then the voltage is again increased. If the measured power decreased, then the voltage is decreased. This iterative process continues indefinitely, but eventually this method will oscillate around the true maximum power point. This method is possible because the derivative of the I-V curves of the solar cells increase to a single peak (the maximum power point) and then decrease.

That is, the positive slope direction of the curve always points to the maximum power point. [15]

Recall that conductance is the inverse of resistance, or the quotient of current divided by voltage. In the incremental conductance technique, the voltage and current changes and thus the conductance changes are tracked and computed. This is called the incremental conductance. The location of the current operating point in relation to the maximum power point can be determined by comparing the incremental conductance to the characteristic conductance. The maximum power point occurs when the incremental conductance is equal to the negative of the characteristic conductance. If the incremental conductance is greater than this value, the voltage is increased. If the incremental conductance is less than this value, the voltage is decreased. [15]

In the constant voltage method, an approximation of the maximum power point is determined to be the product of a constant,  $k$ , and the open circuit voltage. That is, the solar cell is regulated at a constant voltage that is proportional to the open circuit voltage. This technique will sample the open circuit voltage periodically, by opening the solar cell circuit, and then from this measurement determine the regulated voltage. [15]

Each of these techniques has their own advantages and disadvantages that will be explored in greater depth in a future section of this text. It should also be noted that all of these methods are implemented in a DC-DC conversion section of these solar cell power circuits.

### **3.2.4 Voltage Regulators**

Voltage regulators are electronic devices that are set to maintain a constant voltage, even as the input voltage changes. Voltage regulators are crucial components of electrical design because many electronic devices require precise constant voltages to operate. As with most electronic components, there are various topologies that can be employed to achieve this constant voltage output. In this section, several active regulator topologies will be explored.

Linear regulators operate at a constant DC operating point and employ active devices such as, operational amplifiers and bipolar junction transistors. The specific linear regulator topology that will be explored takes advantage of the fact that the operational amplifier will adjust its output such that the operational amplifier's inputs match. A voltage divider is used to set a  $V_+$  voltage from the operational amplifier's VCC voltage. Another voltage divider is used to select  $V_{out}$  from  $V_-$ . The output of this operational amplifier is then current limited and sent to the base of an NPN transistor. The DC input voltage is placed on the collector terminal, and the emitter terminal is  $V_{out}$ . This voltage regulation is achieved because when  $V_{out}$  drops below the regulated voltage, then  $V_-$  will be at a lower potential than  $V_+$ . Since the output of the op-amp is proportional to the difference between  $V_+$  and  $V_-$ , the output of the operational amplifier will increase. This increased voltage will then increase the voltage at the base of the NPN transistor, in turn increasing the voltage of the emitter terminal, or  $V_{out}$ . Exactly the opposite process occurs when  $V_{out}$  rises above the regulated voltage. [16]

Another type of active regulator is the switching regulator. Switching regulators rely on the use of pulse width modulation to achieve regulation. Pulse width modulation involves varying the duty cycle of a pulse train, which in turn varies the average voltage. The other fundamental component of the switching regulator is a means of storing energy. In this case, the use of an inductor. A voltage divider is used to sample  $V_{out}$ , and is filtered through a capacitor such that the DC value of this sample voltage of  $V_{out}$  is inputted to the pulse width modulator. The output of the pulse width modulated is a pulse train that appears on the gate of the N-channel MOSFET.  $V_{in}$  is placed on the drain terminal, and the source terminal is connected to the inductor and then  $V_{out}$ . When the MOSFET is turned on the inductor is charged by  $V_{in}$  and current flows to  $V_{out}$ . When the MOSFET is turned off the diode is forward biased, and the inductor will discharge into  $V_{out}$ . This means that there is always current flowing into the load. Finally, a capacitor is placed across the load such that there is a constant voltage across the load.

The presented topologies are simple arrangements used to illustrate the basic electrical principles at work. These are by no means exhaustive, or for that matter, the best topologies, but they do work and are straight forward to analyze. With this in mind, the relative advantages and disadvantages of voltage regulators in the context of this project will be explored in greater depth in a future section.

### **3.2.5 Motors and Control**

Electric motors convert electrical energy to mechanical energy. A motor is comprised of 5 main components. The rotor (or armature), which turns the shaft to deliver the mechanical power. The bearings, which allow the rotor to rotate around its axis. The stator, which is part of the electromagnetic circuit, usually made up of windings or permanent magnets. The windings, which are laid out coils wrapped around a magnetic core, to form magnetic poles when energized with current. And the commutator, which controls the direction of the current flow to the windings. [17] As displayed below in *figure 3.2.v*, current is applied to the windings around the armature to create an electromagnetic field. Since magnetic opposites attract, the armature is rotated accordingly, then once it has rotated halfway, the commutator reverses the current flow through the windings, which then forces the armature to complete its rotation.

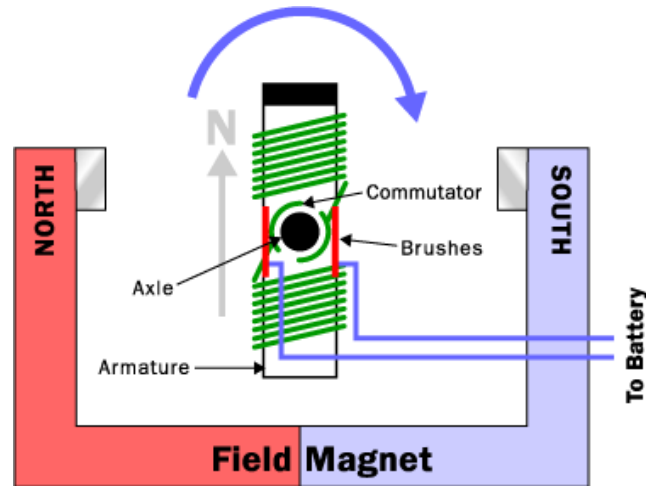

Figure 3.2.v Diagram of a Simple DC Electric Motor [18] (Permission Requested)

### 3.2.5.1 Brushed DC Motors

Brushed DC motors are relatively inexpensive, easy to control, and readily available in a variety of shapes and sizes. [19] Permanent magnet brushed DC motor, like the one pictures in *figure 3.2.5 i*, are the most common brushed motors found in the industry. There are a few other types of brushed motors, these include, shunt-wound, series-wound, and compound-wound. Each of these types have their own benefits. Permanent magnet brushed motors are the most cost effective but are usually lacking in horsepower, so they are used in mainly general applications. However, one drawback of these motors is that their permanent magnets can lose their magnetic properties over time. Shunt-wound brushed motors are typically used in applications requiring five or more horsepower, and provide much better speed and stability control. Series-wound brushed motors can provide much higher torque, but they do not have as precise speed control as shunt-wound. Compound-wound brushed motors are essentially the combination of series and shunt-wound technologies. Therefore, they can provide much higher torque than a shunt-wound motor, and better speed control than a series-wound motor.

### 3.2.5.2 Brushless DC Motors

Brushless DC motors are becoming increasingly more popular over brushed motors. Brushless motors are used in many different industries including automotive, industrial automation, aerospace, and medical. Brushless motors come in single-phase, 2-phase, and 3-phase configurations. [20] The number of these phases corresponds to how many windings the stator has. Brushless motors offer a variety of benefits versus brushed motors. These differences are outlined in *table 3.2.i*, shown below.

	<b>Brushless DC Motors (BLDC)</b>	<b>Brushed DC Motors</b>
Cost	Higher initial cost	Lower Cost
Lifetime	Longer life expectancy due to less fragile parts	Shorter life period
Maintenance	Less maintenance required	Periodic maintenance required due to brushes
Speed range	Can operate at all speeds under rated load	Loss of torque at higher speeds
Efficiency	High efficiency (85-90%)	Moderate efficiency (75-80%)
Noise	Little to no noise	Arcs in brushes typically generate noise
Power-Size	High due to less parts and better heat dissipation	Moderate/Low due to heat generated by the armature
Control	Complex and pricey	Simple, no controller needed

*Table 3.2.ii Brushless vs. Brushed DC Motors [20]*

### 3.2.5.3 Motor Sensor Feedback

There are many sensors used for feedback in motor systems. We will focus mainly on two: the optical encoder, and the hall effect encoder. The optical encoder, as stated in the name, senses the position of the motor uses optics. This is done by the use of a slotted disc, with an IR LED on one side, and a phototransistor on the other. The orientation of these devices is detailed in *figure 3.2.vi* below.

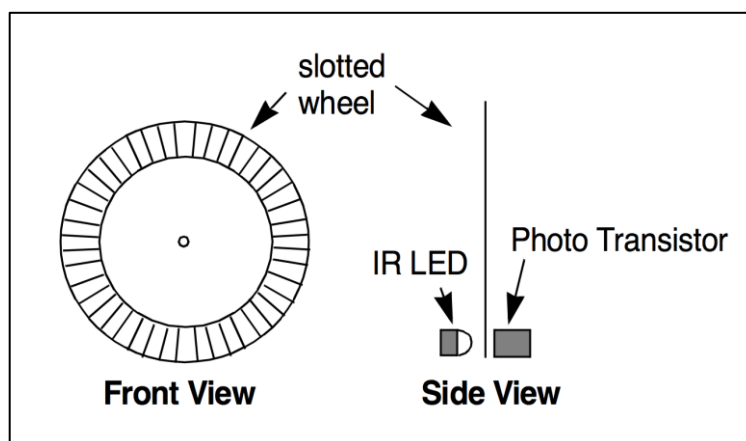

*Figure 3.2.vi Optical Encoder [19] (Permission Requested)*

The slotted disc is mounted to the shaft on the non-load bearing side of the motor, and spins at the same rate as the load. As the disc spins, the IR LED causes photo transistor turns on and off from the gaps in the disc. This sampling can generate data such as position and velocity of the motor system.

The hall effect encoder works very similarly; however, it uses one or more magnets placed on the outside edge of a disc, and a hall effect sensor, which generates a pulse based on proximity to a magnet, to conduct the sampling. This process is shown in *figure 3.2.vii*.

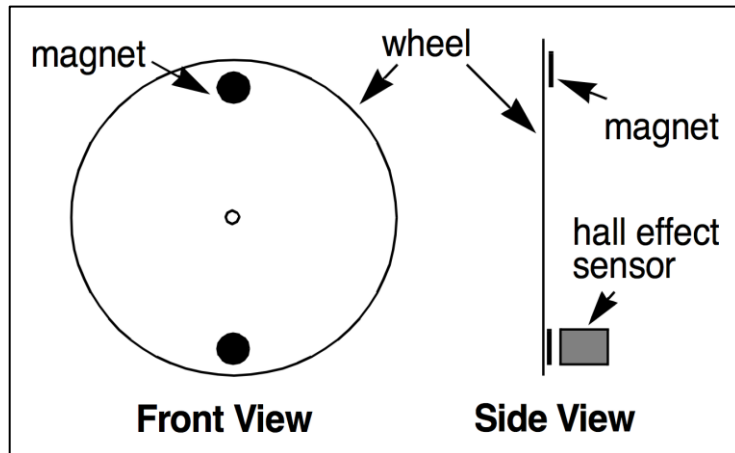

Figure 3.2.vii Hall Effect Encoder [19] (Permission Requested)

### 3.2.5.4 Driving a DC Motor

In order to drive a DC motor, a small circuit of a few components must be developed. There are more than one ways to do this. A simple schematic is detailed in *figure 3.2.viii* below.

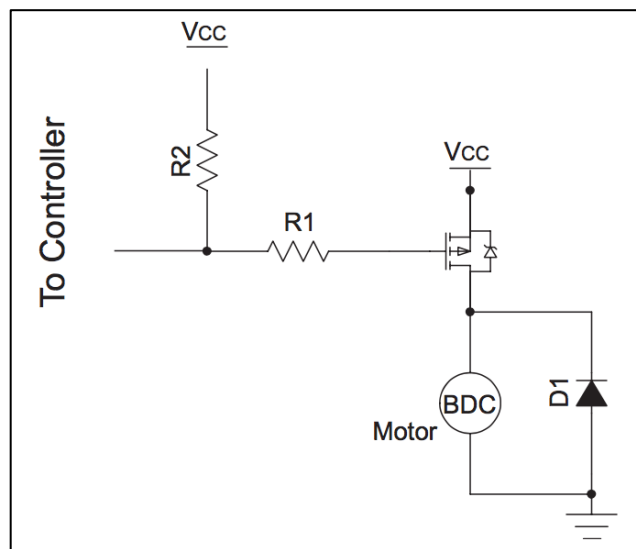

Figure 3.2.viii One Directional Motor Drive Circuit [19] (Permission Requested)

In the circuit above, the microcontroller drives the gate of the MOSFET with a Pulse Width Modulation signal. The motor treats this signal as an average voltage, therefore varying the speed based on the duty cycle of the PWM signal. For example, if the PWM duty cycle is 60%, the motor will spin at 60% of its max speed because it sees 60% of  $V_{cc}$ . R1 in this circuit protects the microcontroller from current spikes, while R2 makes sure that the FET is off when the controller signal is low. The diode D1 is to protect the MOSFET from reverse current flow. When controller tells the motor to stop spinning, there is still charge built up in the motors windings, which can produce a reverse current potentially harming the transistor. The downside to this circuit is that it can only control the motor spinning in one direction. To get around this, for full bidirectional control, an H-Bridge circuit is implemented. The H-Bridge circuit consists of four transistors with similar circuitry as the one directional drive circuit. These are used to switch the current flow direction. Four I/O lines from the microcontroller are necessary. There are multiple different integrated circuit versions of the H-Bridge available on the market, however the circuitry is not all that complicated. The circuit schematic is detailed in *figure 3.2.ix* below.

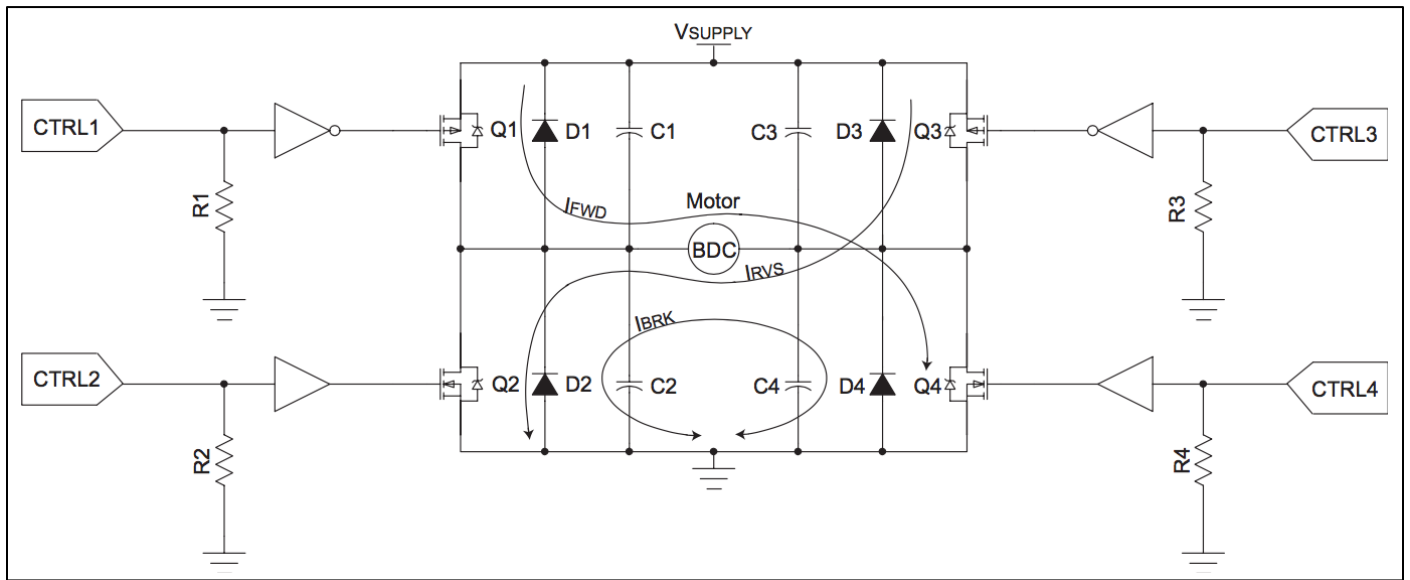

Figure 3.2.ix H-Bridge Motor Driver Schematic [19] (Permission Requested)

The H-Bridge circuit has four modes of operation. When Q1 and Q4 are ON, the motor spins in the forward direction. When Q2 and Q3 are ON, the motor spins in the reverse direction. When all the transistors are OFF, the motor will coast to a stop. To prevent this coasting, Q2 and Q4 can be turned on, which creates a ground-ground short across the motor. This acts as a load with infinite magnitude and will bring the motor to a fairly quick halt.

### 3.2.6 Motion Detection

Motion detection can be achieved through various schemes. In this section, several of these methods will be explored. Specifically, passive infrared (PIR), and microwave methods.

The PIR method involves measuring infrared radiation from an environment. The governing principle behind this method is black-body radiation. Essentially, any body with a temperature above absolute zero radiates heat. In addition to this, the specific spectrum emitted depends entirely, and only, on the temperature of the body. [21] A PIR sensor will detect infrared radiation within its field of view. The ambient temperature that the sensor will constantly read when there is no motion will be room temperature. Then, when an object enters the sensor's field of view the temperature detected will rise from the ambient room temperature. Detecting the motion is achieved by inputting two separate sensors into a differential amplifier. When there is no object, the differential amplifier will output zero. When an object enters the first sensor's field of view the differential amplifier will output a positive signal. When an object enters the second sensor's field of view the differential amplifier will output a negative signal. This output signal can then effectively be used to track the object's direction of travel. To increase the range of these PIR sensors, lenses are added, usually Fresnel lenses. [22] In effect, Fresnel lenses result in large apertures and short focal lengths in smaller form factors, which is very conducive to this PIR application. [23] This configuration is shown in *figure 3.2.x*.

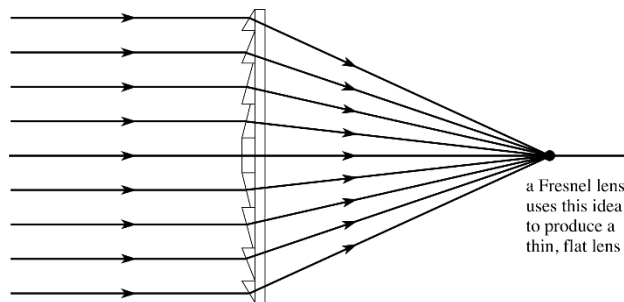

*Figure 3.2.x Fresnel Lens (Permission Requested)*

The next method, microwave, relies on the principle of the doppler effect. That is, the frequency of a wave by an observer will be shifted. [24] These sensors emit microwaves into a scene with a precise frequency. The reflected waves are then detected, and their phases analyzed. If an object is within the scene, the phase of these reflected waves will be altered. [25]

The relative advantages and disadvantages of these various motion detector technologies will be further explored in a future section.

### 3.2.7 IR Remote Control

There are various technologies used in remote control, but for this overview only the infrared technique will be explored. These systems take control of two major components: infrared sensors and infrared LEDs. Additionally, they employ pulse width modulation (PWM) to modulate the infrared signals.

The infrared LED will transmit a PWM signal to the infrared sensor. For this application, the infrared sensors are digital devices. The sensor will either detect an infrared signal or not detect an infrared signal. These sensors are also bandpass filtered to a specific carrier frequency. This is because the sensor only wants to read intentionally PWM infrared signals. Typically, this carrier frequency is around 37 kHz. Pulses of varying duration modulated at this carrier frequency are transmitted from the infrared LED and are captured by the infrared sensor. The sensor will then transmit these varying pulse durations to be decoded by a microprocessor. This signal of varying pulse length is then decoded into various functions. [26] These spectra are shown in *figure 3.2.xi*.

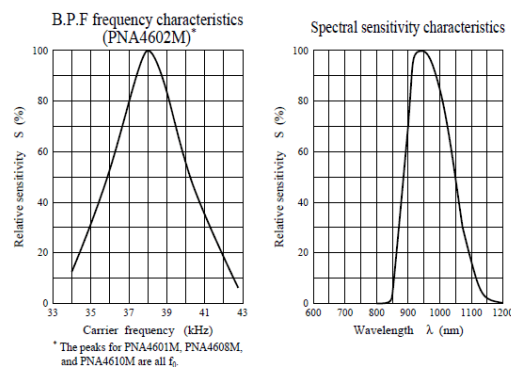

*Figure 3.2.xi. Typical IR sensor Spectra [26]  
(courtesy of Lady ada adafruit user)*

Various coding schemes are available for these pulses. These include, bi phase coding, pulse distance coding, and pulse length coding. Bi phase coding has a rising or falling edge in the middle of each clock pulse. A rising edge means logic 1 and a falling edge means logic 0. The RS-5 protocol, developed by Sony, is an example of bi phase coding. Pulse Distance coding each LED burst has a fixed length, but the time, or distance, between pulses is varied such that a small distance is a logic 0 and a large distance is a logic 1. Pulse length coding seems somewhat of the inverse of pulse distance coding. In pulse length coding the distance between bursts is fixed, but the length of the pulse is variable. A short burst is logic 0 and a long burst is logic 1. [27]

### 3.2.8 Microcontrollers

A microcontroller is a small processing unit, typically in the form of an integrated circuit. Microcontrollers are used in a variety of applications where low cost, embedded circuits are needed. They are used to control most of the electronic devices people use every

day. These include: washing machines, microwaves, coffee makers, gas pumps, anti-lock brakes, drones/quadcopters, alarm systems, thermostats; the list goes on and on. The first microcontroller was developed by intel in 1971. It was the 4-bit Intel 4004. Nowadays, microcontrollers are available in an endless number of configurations including number of bits, amount of storage, type of storage, instruction set, number of I/O pins, etc...

Microcontrollers were originally mainly programmed with assembly language, but since the support for these devices has evolved, so have the programming environments. Nowadays, they can be programmed with a variety of different software IDE's, once the appropriate bootloader/firmware has been installed. A few of those IDE's will be explored in more detail in a later section of this document.

### **3.2.8.1 Microcontroller Architecture**

Learning about microcontrollers is a very important aspect in knowing how to program them. Before selecting a microcontroller, we went in depth as to learn how microcontrollers works in addition what we learned at our university. [28] To start, Microcontrollers are built with something called instruction set architecture, which is the structure that provides commands to guide for processing data manipulation, executing programs with instructions. Microcontrollers come with several addressing modes as well data types, registers, interrupt, exception handling and memory architecture. Most of microcontrollers are built on CISC and RISC instruction set architecture. CISC microcontrollers are structured different than RISC microcontrollers. In olden days, almost all the microcontrollers or microprocessors were built using CISC technology. CISC architecture means that single instruction can execute several operations in one clock cycle. So, there would be fewer lines of code. [29] In other words, each lines of code can be translated into multiple of lines of code, or each lines of code execute multiple of operation. This architecture is bit complex to understand. For example, one instruction construct would be getting data from memory and computing on that data. On the other hand, RISC architecture takes approach of reducing complexity of the instruction by using simple instruction set. This makes processors work faster because instructions are not complex. Von Neumann processor was developed that read and executes one instruction at a time. This makes running multiple instruction simultaneously by using concept of pipelining. Pipelining makes processing easy in parallel. Some of example of the RISC processors are ARM, MIPS, SPARC, and PowerPC. In conclusion, we learned that CISC microprocessors have less lines of code but each lines of code executes multiple tasks at time. RISC microprocessors are opposite in the sense that each lines of code only execute single task, and therefore, would several lines of code. So, smaller tasks but a lot of tasks is rather faster. RISC architectures offers less complexion.

### **3.2.8.2 Microcontroller Communication**

Communication with respect to microcontrollers is another aspect worth exploring. Communication is a data exchange between two devices. The question how does it communicates or exchange data between two devices. Nowadays, data could mean like

video files, email, document files, etc. how do these data transmit from one place to another. Bluetooth, IR, Wifi, cables are few ways devices can be configured to send/receive data. Most of the computers transmits data sequentially. Next topics is how do we communicate from device to another over network. For example, how does our microcontroller communicate to the webserver on the internet. how do we send/receive commands or data from and microcontroller to web-client interface?

Serial communication is the technique used to send/receive data in one bit at a time. However, Parallel communication refers sending/receiving multiple data bits at a time through parallel channels. Both types of communication use clock system, so in clock cycle, serial communication would be transmitting one bit, wherein, parallel communication scheme, multiple bits are transmitted using multiple channels. Obviously, we would encounter time lag between transfer of bits to the destination from one channel to another channel, otherwise called overhead, or clock skew. What we realize is that sending multiple data bits over different channels would be slower than sending one bit of data fast. With parallel communication, we are constrained to clock rate since every channel is using the same clock rate. However, in serial communication, we can speed up the clock rate and send smaller bits faster. With this reasoning, serial communication far better option and it is cheaper to implement. Hence, many ICs in microcontrollers have serial interfaces, which allows of having fewer pins. We realized that transmitting data over serial communication obviously better choice due above reasons. However, with serial communication, we have an issue of knowing where is the start/end of data set. We must have a way of relating a data. So, we understood ways of transmitting data serially with asynchronous and synchronous. Asynchronous data transfer is protocol that states the when communication begins, first bit represents the start bit, followed by the data bits, then stop bit to represent end of the data set. On other hand, synchronous data transfer simply means that data bits are sent to the destination when the clock begins and stop transmitting when clock stops. Lastly, in serial communication, baud rate is required for communication over two devices. Both devices must have the same baud rate, otherwise, one device might be transmitting the data bits, but another device may not receive it. [30]

TCP/IP is another method of communication. TCP/IP is a combination of two protocol which is used to specify how data is transmitted over the internet by providing end-to-end communication. furthermore, TCP defines how applications can generate channels of transmission over network. It manages how data is bundled into packages before transmitting, it over the network, and is also responsible for unbundling the packages in correct sequence at the destination. IP protocols defines how each package is address and routes to correct destination. There many forms of TCP/IP protocols that used. The most common are HTTPS, FTP, SMTP, etc. HTTP is used to communicate between web client and web server for data transmission. In this project, we will be taking advantage of HTTP protocol to communicate from client to web server, and vice versa. [31] HTTP, or, Hypertext Transfer Protocol is the series of regulation for transferring files on the internet. HTTP is an application protocol that runs on top of the TCP/IP protocol. The standard port for HTTP is port 80.

UART (<https://learn.sparkfun.com/tutorials/serial-communication/uarts>) is a microchip with Programming that runs microcontroller's interface to its attached serial device.

Likewise, A universal asynchronous receiver/transmitter, UART, is used for serial communication. UART is a bus of eight data lines, or 16 data lines with some additional control pins. on the other side, is the two serial wires- RX and TX. UART do exist as separate ICs, commonly located inside the microcontrollers. As RX and TX, represent both sending and receiving serial data. UART is responsible for creating data packets, with synchronization and parity bits, sending that packet out the TX line. On destination side, UART must be ready to receive transmission at specified baud rate, with removing parity bit, start and stops bit, using data bit for the tasks. This is shown in *figure 3.2.xii*.

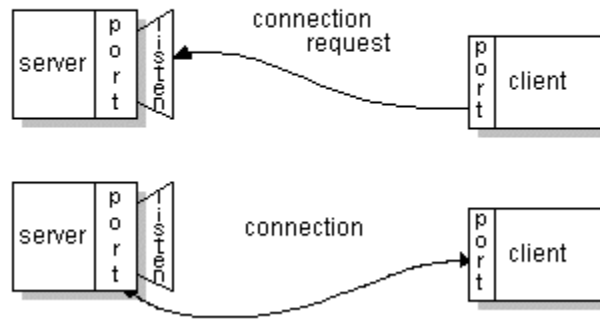

*Figure 3.2.xii HTTP Flowchart (Permission Requested)*

A socket is single endpoint of two-way communication between two programs on a network. Socket is constrained to port number so that TCP protocol can recognize the application that data should go to. Initially, server that has socket that is constrained to port number. Server waits and listens to the socket for a client to submit a connection request. On client side, the client knows the hostname as well as port number on which the server is running. When client tries to connect to the server, client needs to identify itself to the server, so it uses a local port number for validity of the connection. If connection becomes successful, server would create new socket bound to the same old local port for new request for connection, and it would create new socket bound to the port number and address of the client. In our project, socket will be used to communicate from our microcontroller to http server. [32]

REST has become one of the most significant technologies for web application. Every language now includes frameworks for building RESTful Web services. REST stand for Representational state transfer for hypermedia application over network. Although, REST is not dependent on any protocol, almost every RESTful service uses HTTP as its core protocol. The main reason RESTful service is used provide client to the resources. This resource can be though as objects. Another great thing about REST services is that resources can be in format. For example, resources can be in format like JSON, or XML. This technique is widely used, and we will be using this technique communication from client to the server and server to microcontroller. [33]

### 3.2.9 LEDs

Since the smart shades will, in some respects, be part of the decoration of many smart homes, having LEDs on them seems like a very appealing part to add to the shades. So, understanding how LEDs function is an important aspect for designing the smart shades.

LED is an acronym that stands for “Light Emitting Diode”. A diode’s main function is to control the direction of current-flow. It has two polarized terminals called the anode (the positive terminal) and cathode (the negative terminal). Ideally, current would only flow from the anode to the cathode. However, there is a reverse saturation current (in the order of nA) that can flow in the opposite way of what is wanted (from the cathode to the anode) and a breakdown point where a large amount of current is able to flow in the opposite direction once the voltage applied is large and negative. [34] This is shown in *figure*

3.2.xiii.

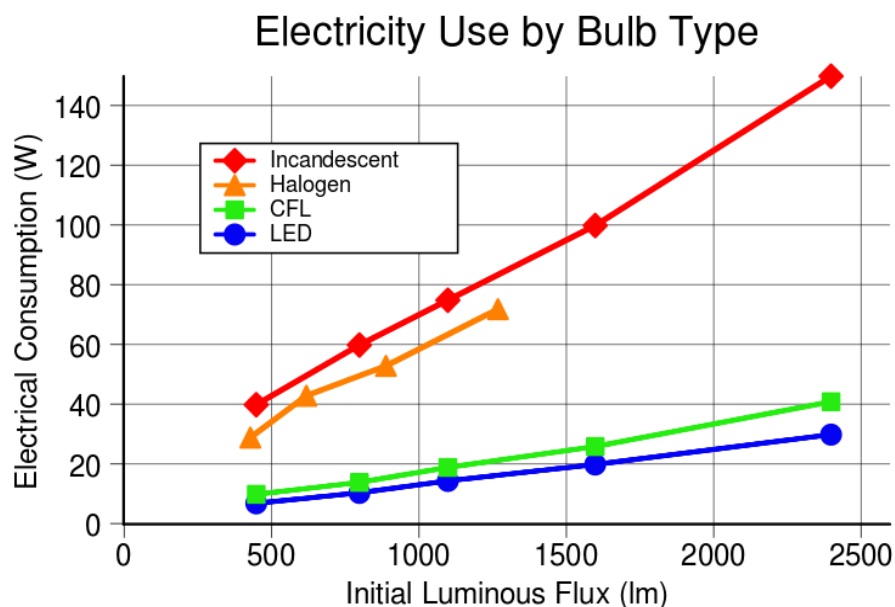

Figure 3.2.xiii Comparing LED Output (Permission Requested)

LEDs convert electrical energy into light. Light is released when the electrons supplied to the LED are able to recombine with the electron holes within the device. [35] The more current that is put into them, the more light they produce (up to a point). [36] They use a noticeable amount less power to produce light compared to lightbulbs and are more energy efficient. They don’t have a filament that will burn out and they don’t get as hot as regular lightbulbs. This makes the LEDs able to last longer than incandescent lightbulbs as well. [37]

There are many different types of LEDs that could possibly be used for the smart blackout shades. RGB (Red-Green-Blue) LEDs are basically three LEDs combined into one. The intensity of each of the three colors can be controlled allowing any color of the rainbow to

be displayed. These LEDs usually have one pin for each color and a common pin either being the anode or cathode for a total of four pins. [36]

White LEDs are either produced from mixing the three primary colors, red, green, and blue together or monochromatic light from a blue or UV LED is converted to broad-spectrum white light through the use of a phosphor material. There are three main ways of mixing colors to make an LED produce white light. Using a blue LED, a green LED, and a red LED through color mixing is one way. Using near-UV or UV LED and a RGB phosphor is another way. Using a blue LED and a yellow phosphor is the third and most efficient way. It combines two complementary colors to form white light. It is possible to have noticeably different spectra appear white because of metamerism. This may have to be taken into consideration if white LEDs are used with the smart blackout shades.

Flashing LEDs are able to blink on and off without any outside controller by utilizing an integrated circuit within the LED. Flashing LEDs have a RGB version that can cycle through a large number of colors. SMD (Surface Mount Device) LEDs allow for a selection of LEDs with different sizes. [36] These can help conserve space which might be ideal to put on the smart blackout shades.

LEDs are considered to be High-Powered LEDs if they can dissipate 1 Watt or more of power. Many of these LEDs can be bundled together to create something like a spotlight. Due to the high power usage, these LEDs will often utilize a heatsink to transfer much of the wasted heat to the surrounding air. [36]

Infrared LEDs and ultraviolet LEDs are LEDs that emit light outside of the visible light spectrum. Infrared LEDs are commonly used in remotes which, the smart blackout shades will be using. Small pieces of information are sent through the infrared light. Ultraviolet LEDs can be used for disinfecting surfaces due to many kinds of bacteria being rather sensitive to the UV radiation given off by these LEDs. [36]

One of the main issues with LEDs is that they have a higher upfront cost compared to incandescent lightbulbs. However, due to how energy efficient they are, LEDs can end up costing less money in the long run when the cost of power is added to it. Since LEDs do not contain the toxic mercury that incandescent bulbs have, disposing of LEDs is much easier in comparison. For plant growth, LEDs outperform incandescent bulbs due to being able dim easily while also not producing a lot of harmful heat towards the plants. [37]

For most LEDs, their typical lifetimes can be extended or shortened drastically from heat and their current settings. However, their typical lifetimes are quoted to be between 25,000 and 100,000 hours. Their efficiency is higher at lower temperatures. A comparison of lightbulb lifetimes is made clearly in *table 3.2.iii*.

Table 3.2.iii LightBulb LifeTime Comparison

	<b>Incandescent</b>	<b>CFL</b>	<b>LED</b>
Approximate cost per bulb	\$1	\$2	\$8 or less
Average lifespan	1,200 hours	8,000 hours	25,000 hours
Watts used	60W	14W	10W
No. of bulbs needed for 25,000 hours of use	21	3	1
Total purchase price of bulbs over 23 years	\$21	\$6	\$8
Total cost of electricity used (25,000 hours at \$0.12 per kWh)	\$180	\$42	\$30
<b>Total operational cost over 23 years</b>	<b>\$201</b>	<b>\$48</b>	<b>\$38</b>

Table 3.2.iii shows how beneficial using LEDs instead of incandescent bulbs or compact florescent lamps would be in the use of the smart blackout shades. While the initial cost of LEDs will drive the buying price for the smart blackout shades up, it overall saves the user money in the long run due to being more efficient in emitting more lumens per watt. LEDs can emit the light of any intended color and are easily attached to printed circuit boards. They light up very quickly, can be dimmed by either pulse-width modulation or by lowering the forward current, and are difficult to damage with external shock.

### 3.2.10 Wireless Technologies

In this section, various wireless technologies will be researched and explored, in detail. This will ultimately help us choose which method of wireless communication is best for our project.

#### 3.2.10.1 Wi-Fi

The wireless networking protocol known as Wi-Fi uses a wireless adapter to create hotspots allowing multiple devices to communicate to each other and access internet services without the use of an internet cord. Wi-Fi is based on the 802.11 IEEE network standard and represents a type of wireless LAN (local area network) protocol. The Wi-Fi Alliance came up with the word Wi-Fi and it is now a trademark of theirs. Wi-Fi has been made available in many homes in the U.S. and using it as a way for the smart shades to communicate is worth looking into. [38] An example WLAN is shown in figure 3.2.xiv.

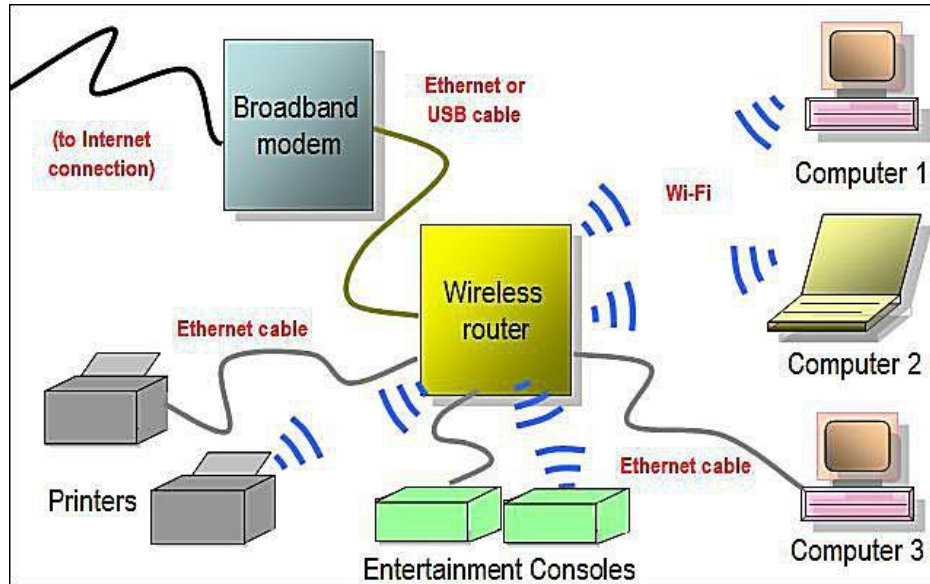

Figure 3.2.xiv Example WLAN with wireless router [136] (Permission Requested)

Wi-Fi allows for two-way traffic within its area of use. This is important for the smart blackout shades as two-way traffic will be utilized. When a device is receiving information via Wi-Fi, it utilizes a wireless adapter to receive radio waves from the wireless access point or router [9]. A wireless router can act as a wireless access point but a wireless access point cannot do everything a router can do. It is the wireless access point that transmits the internet connection provided by an Internet Service Provider and transmits the information needing to be sent by emitting radio waves. These radio waves could cause interference with other smart home devices and will have to be carefully considered in order to keep the smart blackout shades desirable.

The area created by the sending these waves is often referred to as a wireless local area network (WLAN). Within this wireless local area network, Wi-Fi will be available. However, the range of communication is largely dependent on whether it's being used outside or inside, how high above the ground it is, the state of the weather, the frequency used, whether there are many nearby obstructions, the type of antenna used, and whether or not there are other devices utilizing the same frequency. [39] Similarly to receiving information, when a device wants to send information using Wi-Fi, the device sends its own radio signal to the wireless access point which is then sent back to the Internet via an Ethernet connection on an adjacent wired LAN. [40]

The radio signals Wi-Fi operates on are transmitted at a frequency level of 2.4 GHz or 5 GHz. The 802.11 networking standards dictate how this works. 802.11a transmits data at the 5 GHz frequency level and allows for up to 54 megabits of information to be sent per second. The 802.11n also transmits at the 5 GHz frequency level; however, this allows the transmission of data to be up to 140 megabits per second. The 802.11b and 802.11g both operate at the 2.4 GHz frequency level and have a slightly better range than

802.11a's. The 802.11b sends data at a maximum of 11 megabits per seconds whereas the 802.11g will transmit data up to 54 megabits per second. [41]

Due to the frequency band being at 2.4 GHz for both the 802.11b and 802.11g standards, the type of equipment to utilize these two could experience interference from Bluetooth devices, wireless telephones, security cameras, baby monitors, ZigBee devices, and microwave ovens because all of these devices also use the 2.4 GHz frequency band. This interference can hinder the quality of the connection or lower the speed at which the data is being transferred. In areas of high-density that contains many Wi-Fi access points, more interference can be caused from the channels overlapping. [38] The Wi-Fi strength will have to be tested based on what part is chosen for the smart blackout shades.

The hardware Wi-Fi can utilize includes a wireless access point, a wireless adapter, a wireless router, and embedded systems. A wireless access point is what allows a device to connect to a wired network through Wi-Fi. It relays data between the wireless devices connected to it and a wired device. [38]The number of clients that a wireless access point can support depends on various things like the desired client throughput, the density of the client environment, and the type of access points in use. [39] A wireless adaptor enables devices to associate with a wireless network. A wireless router combines a wireless access point and a router. Many embedded systems now have Wi-Fi modules that allow any device that communicates through a serial port to be wirelessly enabled to transmit data. [38] Therefore, it will be rather easy to find something suitable for the smart blackout shades' microcontroller to utilize in order to provide Wi-Fi.

The smart blackout shades considered using an Ethernet cable for the purpose of communicating since this type of connection has faster speeds, lower latency, and more reliable connections than Wi-Fi, Wi-Fi is still more convenient due to the large area it can be used in. While Ethernet cable connections have faster speeds, lower latency, and more reliable connections than Wi-Fi, Wi-Fi is still more convenient due to the large area it can be used in. Since the smart shades will be put at any window inside a home, Ethernet ports are likely not going to at every window. In comparison, a typical Cat5e cable can go up to 1 gigabits per second whereas the 802.11 standard can only go up to 150 megabits per second. While transferring data between two devices in a house would be much faster with Ethernet, the download and upload speeds provided by the internet service provider being used can set this speed as a limit despite the connections being capable of having higher speeds. The smart shades won't be requiring a fast connection speed since it will not be needing to send large amounts of data in a relatively fast manner. [42]

Latency, the amount of time it takes for traffic to travel between a device and its destination, should not play too much of an important factor for the smart shades as well. So, despite a wired Ethernet connection having significantly less latency than Wi-Fi, Wi-Fi is still a good and reasonable choice. [42]

Wired Ethernet connections don't have to worry about they interferences that can affect Wi-Fi signals. Interferences causing interruptions can worsen the aspects that Wi-Fi already loses to in comparison with wired Ethernet connections. Wi-Fi also doesn't have as good security measures as wired Ethernet does. However, we believe that Wi-Fi's

capabilities will be enough for the purposes that the smart shade will use. This, along with the incredible convenience it gives are the main reasons why we chose to use Wi-Fi instead of wired technologies. [43]

### **3.2.10.2 Bluetooth**

Bluetooth was invented in 1994 to be an alternative to RS-232 data cables. IEEE standardized Bluetooth as IEEE 802.15.1 but doesn't maintain this standard anymore because the Bluetooth Special Interest Group (SIG) manages everything dealing with Bluetooth now. In order to market a Bluetooth device, manufacturers must meet Bluetooth SIG standards. The medieval king of Denmark, King Harald Gormsson of Denmark had the nickname of King Harald Bluetooth which is where the idea for the name Bluetooth came from. The Bluetooth logo is the King's initials as a combination of two Scandinavian runes. Bluetooth is a low-powered short distance technology standard that allows the transmission of data. [44] There are two kinds of Bluetooth technology, Basic Rate/Enhanced Data Rate and Low Energy.

Basic Rate/Enhanced Data Rate Bluetooth uses and establishes a one-to-one (1:1) communication between 2 devices using a point-to-point (P2P) network topology while allowing the wireless connection to be continuous. Wireless headsets, wireless speakers, and hands-free in-car systems are ideal markets as Bluetooth Basic Rate/Enhanced Data Rate is optimized for audio streaming services. [45]

Bluetooth Low Energy enables short-burst wireless connections and also has a point-to-point network topology along with broadcast and mesh network topologies. The Bluetooth Low Energy point-to-point topology is for one-to-one device communications that benefit from data transfers being optimized. This is ideal for connected device products such as fitness trackers, health monitors, and wireless keyboards, trackpads, and mice. The smart blackout shades would most likely use this topology as only the smart phone would need to use Bluetooth to communicate with the shades. The Amazon Echo would still have to use the Wi-Fi and the remote would be using IR. Having both the Amazon Echo and the smart phone communicate to the smart shades through the Wi-Fi will help keep consistency. [45]

Bluetooth Low Energy broadcast topology is ideal for beacon related solutions such as item and way-finding services and point-of-interest information since it supports localized data sharing by establishing one-to-many (1:m) device communications. Point-of-interest beacons have many applications within tourism, education, transportation, and museums. Item-finding beacons are good for services such as finding lost keys, a lost purse, a lost wallet, or any other lost item containing a Bluetooth beacon. Way-finding beacons are helpful with navigating through crowded areas such as campuses, stadiums, or airports. [45]

Using a mesh topology to establish a many-to-many (m:m) device communication, Bluetooth Low Energy mesh is well suited for sensor network and asset tracking solutions and building automation as it is optimized for creating very large-scale device networks.

Building automation allows for an enormous amount of wireless devices to reliably and securely communicate with one another. [45]

At the frequencies between 2.402 GHz and 2.480 GHz is where Bluetooth operates. If the guard bands are included, it operates at 2.400 GHz to 2.4835 GHz. This is within the 2.4 GHz short-range radio frequency band that Wi-Fi utilizes as well. On this range, Bluetooth utilizes a process of radio technology known as frequency-hopping spread spectrum. This process partitions the transmitted information into packets. Each packet is then transmitted onto one of 79 designated Bluetooth channels each having a bandwidth of 1 MHz. About 800 jumps between channels are performed per second when Adaptive Frequency-Hopping (AFH) is enabled. Bluetooth Low Energy topologies only utilize 40 channels, each having 2 MHz spacing instead of 1 MHz. [44] This spectrum is shown in *figure 3.2.xv*.

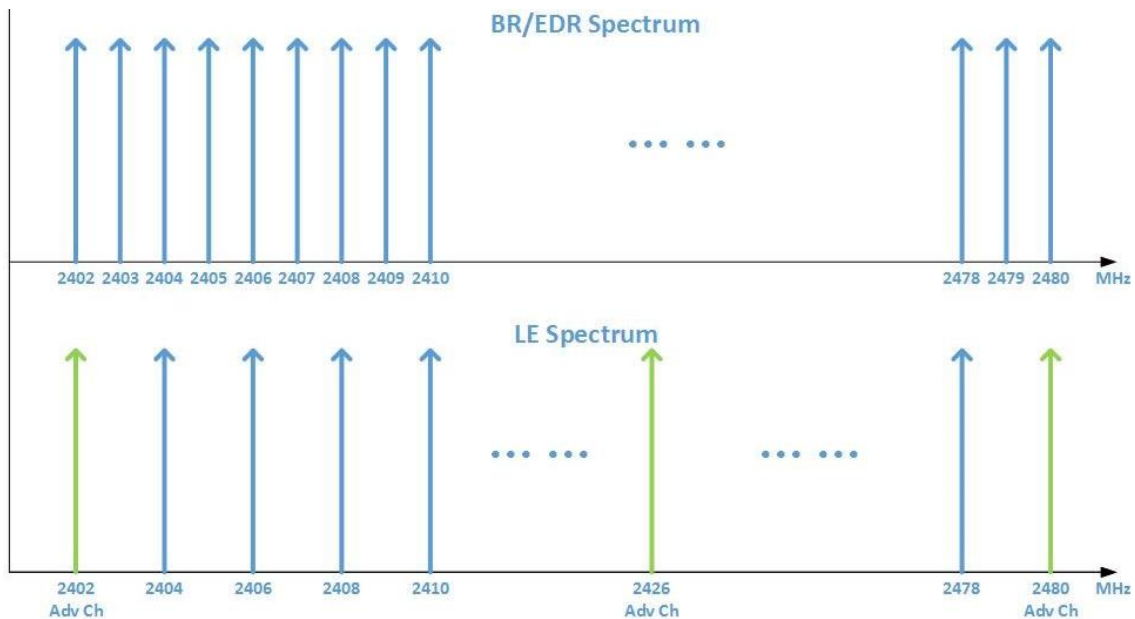

*Figure 3.2.xv BR/EDFR Spectrum vs. LF Spectrum [137] (Permission Requested)*

Bluetooth uses a master/slave architecture for its packet-based protocol. Up to seven of the slaves are able to communicate with one master. This is done the dynamic typology of a piconet which contains a maximum of eight and a minimum of two Bluetooth peer devices. [45]The master's clock, which ticks at 312.5  $\mu$ s intervals, is shared by all devices. In single-slot packets (two clock tick packets) the master's transmission begins in even slots while receiving in odd slots. The slave's transmission is the exact opposite where the slave begins in odd slots and receives in even slots. [44]

When communicating with each other, the master and slave can switch roles by agreement. Data can be transferred between the master and one of the other devices at any given time (unless broadcast mode is being used). Typically, the master device switches quickly between the slave devices in a round-robin fashion. [44]

*Table 3.2.iv Class Devices' and their Power and Ranges*

Class of Radio	Max. Permitted Power (mW)	Typical Range (m)
1	100	~100
2	2.5	~10
3	1	~1
4	0.5	~0.5

A radio (broadcast) communications system is used by Bluetooth devices. *Table 3.2.iv*, shows the power usage and typical range of different classes of radio. Most Bluetooth are battery-powered Class 2 devices allowing for a range of about 33 feet. [44]

Bluetooth 5 is the most recent specification that SIG has released. This specification offers options to modify the speed, range, broadcast capacity, and data rate. Increasing the packet lengths can increase the data broadcasting capacity of transmissions. The range can be increased if the data rate is lowered. The speed can be doubled to 2 megabits per second by sacrificing range. Devices such as the Samsung Galaxy S8 and the iPhone X are capable of using Bluetooth 5. [44] For cost-related reasons, the smart blackout shades would probably use earlier versions of Bluetooth such as Bluetooth 4.0 if we were to utilize this form of wireless communication.

Despite utilizing the same standard signal range that conventional Wi-Fi (IEEE 802.11) uses, Bluetooth is unable to provide the same level of quality for wireless connectivity. Bluetooth networking is overall slower, more limited in range, and supports a fewer amount of devices compared to Wi-Fi. [44] Bluetooth's main purpose is to connect devices without the use of cables. Wi-Fi's main purpose is to provide high-speed internet access for a device without using cables.

So, in some cases, Bluetooth networking is still more useful than Wi-Fi. In portable devices, Bluetooth can serve its applications in a more efficient way than Wi-Fi could. For example, Bluetooth would be very efficient in basic applications where two devices have to connect or pair with minimal configuration. Wireless control between a mobile phone and a handsfree headset, a mobile phone and a Bluetooth compatible car stereo system, a mobile phone and a wireless speaker, and many more applications specifically use Bluetooth instead of conventional Wi-Fi. [44]

### **3.2.10.3 Zigbee**

Developed by Zigbee Alliance, Zigbee is an IEEE 802.15.4-based specification that enables high-level communication protocols used to create personal area networks with low-power, small digital radios. Zigbee uses a wireless ad hoc network for applications such as remote monitoring and controlling and sensor-monitoring. [46] Zigbee is popularly used in home automation because it allows for Zigbee-enabled devices be controlled by a user while operating and working together. This makes it an important wireless technology to research and consider for the use in our project.

Zigbee is not centered around the point-to-point market like Bluetooth is, nor is it for transmitting data at a fast speed through a wireless network like standard Wi-Fi. Zigbee instead focuses on sending data across a large area to all or any of the devices that are low-powered and controllable through multiple hops. [47]Zigbee’s defined data rate is 250 kilobits per second because it is best suited for intermittent data transmissions from an input device or a sensor. The Zigbee specification defines their technology as simpler and less expensive than general wireless networking like Wi-Fi or other wireless personal area networks such as Bluetooth. Some applications that utilize Zigbee are traffic management systems, home energy monitors, wireless light switches, and other industrial and consumer devices that require short-range low-rate wireless data transfer. [46] Applications that have similar designs as the smart blackout shades.

Depending on the power output and environmental characteristics, the low power consumption limits transmission distances between devices to 10-100 meters in their line-of-sight. These devices usually require secure networking and a long battery life. Long distances are able to be utilized to transmit data by using a mesh network of intermediate devices to pass data to long distant devices. [46] Shown in *figure 3.2.xvi*.

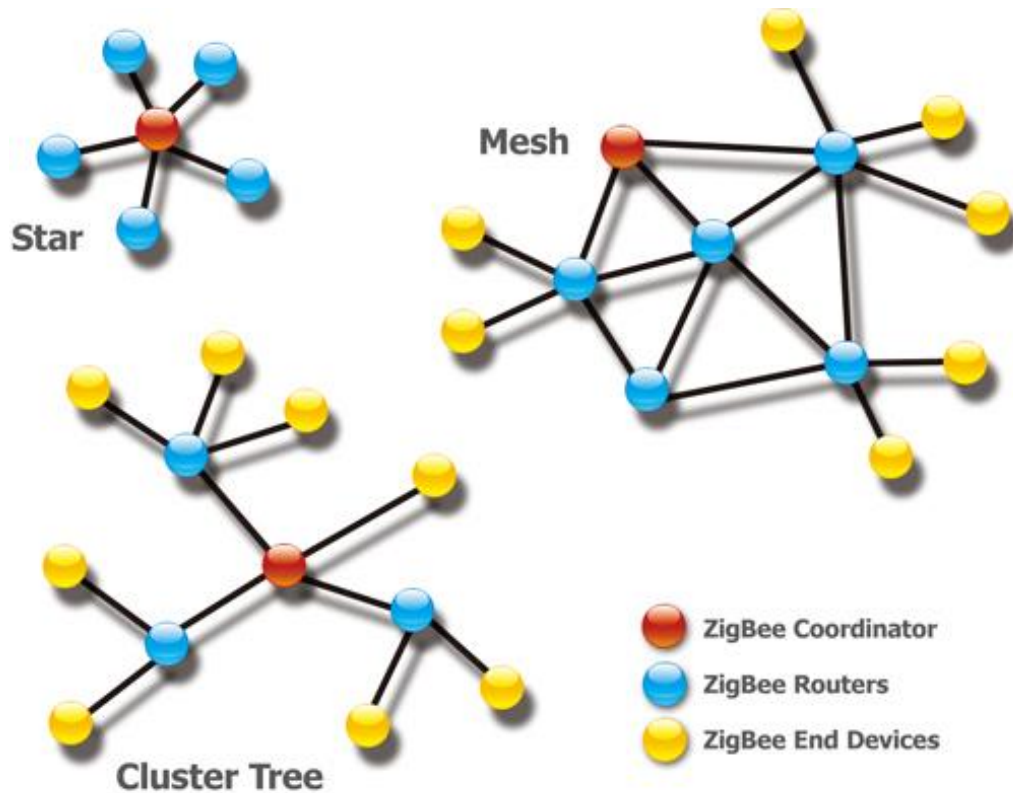

*Figure 3.2.xvi Zigbee-supported Networks [138] (Permission Requested)*

While star and tree typical networks are supported by Zigbee, a key aspect of its protocol is supporting mesh networking. Mesh networking allows a greater data transmission range and provides better stability. Zigbee’s protocol for these networks contain three types of nodes: coordinators, routers, and end devices. [48] Zigbee can support up to

65,000 nodes on a single network. [47] Each node can send and receive data yet they each have their own unique role. In each network, there is one coordinator that has the role of storing information about the network. This includes its security keys. Zigbee Routers are used as intermediate nodes that relay data from other devices as well as running an application function. The end devices are low-power or battery-powered devices that communicate to the coordinator and routers but are unable to transmit data to other end devices. [48] This helps the device retain a longer battery life due to the node being allowed to sleep for a significant amount of the time. [46] If Zigbee were to be used, the smart blackout shades would be able to communicate to other smart home devices.

The Zigbee Alliance uses the Zigbee standard to simplify the integration of wireless product to enable the respective product manufacturers to bring energy-efficient wireless control into their products in a more cost-effective and quicker approach. These standards offer secure, reliable, low-power, and easy-to-use wireless communication. [48]

Zigbee operates in one of the license free bands at 2.4 GHz in most places worldwide and 915 MHz for North America. There is a maximum data rate of 250 kilobits per second for the sixteen different channels provided at the 2.4 GHz band. For the 925 MHz band, there are ten channels that support a maximum data rate of 40 kilobits per second. [49] Zigbee adds onto the media access control and physical layer defined in IEEE standard 802.15.4 four additional key components: a network layer, an application layer, manufacturer-defined application objects, and Zigbee Device Objects. Zigbee Device Objects are responsible for device discovery, security, managing requests to join a network, and keeping track of device roles. [46]

Zigbee Routers are used as intermediate nodes that relay data from other devices as well as running an application function. The end devices are low-power or battery-powered devices that communicate to the coordinator and routers but are unable to transmit data to other end devices [22]. This helps the device retain a longer battery life due to the node being allowed to sleep for a significant amount of the time [19].

The Zigbee Alliance uses the Zigbee standard to simplify the integration of wireless product to enable the respective product manufacturers to bring energy-efficient wireless control into their products in a more cost-effective and quicker approach. These standards offer secure, reliable, low-power, and easy-to-use wireless communication [22]. Incorporating these standards with the standards that our project already intends to follow could become complicated.

Zigbee uses packets to transfer data. The maximum size of these packets are 128 bytes which allows for the payload to be up to 104 bytes. Since applications in which Zigbee and 802.15.4 are likely to be used large data rates aren't needed. With the Zigbee standard supporting 64 bit IEEE addresses along with 16 bit short addresses, each device will have a unique IP address up to over 65000 nodes. There is also an optional superframe structure with a method for time synchronization. [49]

For our project to utilize Zigbee, it would have to operate in one of the license free bands 915 MHz for North America. There is a maximum data rate of 250 kilobits per second for the sixteen different channels provided at the 2.4 GHz band. For the 925 MHz band, there

are ten channels that support a maximum data rate of 40 kilobits per second. Zigbee adds onto the media access control and physical layer defined in IEEE standard 802.15.4 four additional key components: a network layer, an application layer, manufacturer-defined application objects, and Zigbee Device Objects. Zigbee Device Objects are responsible for device discovery, security, managing requests to join a network, and keeping track of device roles. Having to design the project to utilize these, more time and work would have to be devoted to customizing the shades to these standards.

### **3.2.10.4 Z-Wave**

Primarily used for home automation, Z-Wave is a wireless communications protocol that implements a mesh network that uses low-energy radio waves to allow appliances to communicate with each other. This lets residential appliances and devices such as garage door openers, windows, locks, security systems, lighting control, thermostats and swimming pool openers be wirelessly controlled. It is similar to Zigbee in many ways. It is used in smart homes as well so our group looked into whether or not Z-Wave would be suitable for our project.

A Z-Wave automation system can be controlled through various means through the use of a Z-Wave gateway or central control device that serves as both the hub controller and as a portal to the outside. A wireless keyfob using the Internet, a wall-mounted keypad, and a smartphone, tablet, or computer are all able to control a Z-Wave automation system. The smart blackout shades could possibly be made to be Z-Wave compatible since Z-Wave is becoming more and more popular in smart homes. [50]

One of the key differences between Z-Wave and other means of wireless communication is Z-Wave's interoperability. Z-Wave's interoperability layer allows all Z-Wave hardware and software to work together by ensuring that each device can share information. Any node is enabled to talk to adjacent nodes directly or indirectly through Z-Wave's wireless mesh networking technology which allows them to control any additional nodes. If the nodes are within range of each other, they communicate directly. If the nodes are not within range of each other, they are able to link with another node that is within range of both to access and exchange information. Zigbee has something similar to this, which, if our smart blackout shades utilized, would require more time to set up. [50]

Being designed to provide low-latency, reliable transmission of small data packets at data rates of up to 100 Kbit/s, Z-Wave is suitable for sensor and control applications, having a throughput of 40 Kbit/s. Since our group included motion control sensors in the design of the smart blackout shades, it would allow Z-Wave to be fully utilized. This also makes Z-Wave distinct from Wi-Fi and other IEEE 802.11-based wireless LAN systems since those are designed primarily for high data rates. Z-Wave gives enough coverage for most residential smart homes by allowing the communication distance between two nodes to be about 30 meters and having the ability for a message to hop up to four times between nodes. [50]

Z-Wave operates at 908.42 MHz in North America using the Part 15 unlicensed industrial, scientific, and medical (ISM) band. This allows them to avoid interference with Wi-Fi,

Bluetooth, and other systems operating in the 2.4 GHz band. A Z-Wave network can contain up to 232 devices. However, Z-Wave supports bridging networks if more devices are required. [50]

In order for a device to be controlled via Z-Wave, it must be included into the Z-Wave network through the process of pairing or adding. This only needs to be performed once since the device will always be recognized by the controller after this point. During this process, the controller learns the signal strength between the devices. This means that the architecture expects the devices to be in their intended final location before they are added to the system. To allow the controller to be unplugged temporarily and taken to the location of a new device for pairing, it is typically given a small internal backup-battery. [50]

A Network ID being the common identification of all nodes belonging to one logical Z-Wave network is assigned to each device by the primary controller during the inclusion process. It is 4 bytes long. If two nodes have different Network IDs, they cannot communicate with each other. Each device has Node ID that represents the address of a single node in the network. The Node ID must be unique within the network it's in and has a length of 1 byte. [50]

Most of the time, the Z-Wave chip is in a power saving mode, waking up only to perform a function, in order to consume less energy. This allows batteries in devices to only need to be replaced every couple of years. Utilizing this in the smart blackout shades would be appealing to most users. However, with the use of solar energy, recharging the battery seems like a wiser option. [50]

### **3.2.10.5 Comparison of WiFi and Bluetooth**

In designing this project, we had several discussions in figuring out what kind of wireless functionality we will be using for communication in our project. Before, we go into our selection process, we gathered few comparison notes as to what will we be using for our communication needs. We had debated over choosing between Wifi vs Bluetooth. Based on, AutoDesk, Bluetooth and Wifi both have very different domains that they both serve as far as communication perspective. Bluetooth has gone through several updates and long time in making, from 2.0 to 4.0, making more stable. Similarly, Wifi has come a long way as far as updating and getting stronger. Initially, Wifi was operating using standard known as 802.11b to now, it recently was started using 802.11ac. 802.11ac offers both 2.4ghz and 5ghz frequencies, with higher speed, and security protocol. More specifically, Bluetooth only works in 2.4GHz frequency, whereas many Wifi will operate under 2.4ghz as well as 5ghz. Bluetooth 4.0 can only transfer data up to 25 MBPs, whereas the newest version of Wifi can transfer data up to 250Mbps. One of the most important thing that might affect our project will be range of the connectivity of the Wifi network typically withstand. More importantly, the range on a Bluetooth networks is about 30 meters in radius, whereas, newest version of Wifi can expand up to 100 meters in radius. Power is another important aspect that we must consider. Wifi uses way more power than Bluetooth due to the range of connectivity, bandwidth and ability to transfer large data. Choosing Wifi would mean that we would require more power. But on other hand,

choosing Wifi would mean that our product would require more power. Bluetooth offers ability to connect to 7 different devices. However, Wifi doesn't offer that kind of restrictions. However, in conclusion, Wifi and Bluetooth are used that is dependent on the purpose of the project. Wifi also offers ability to connect to the internet which is necessity for our web application to work. [51]

### **3.2.11 Server and Client**

Client-server model is defined as a set of two processes that communicate with one another. For example, one process (the client) can requests a service or resource from another process (server), and server responds with appropriate data, or resource. Master-slave, or peer-to-peer, is another model, in which each node in the network can function as both a server and a client. In this model, server (master) controls multiple other device or process (known as slaves). [52]

HTTP, web protocol, is defined as language that clients and servers use to communicate with each other. The HTTP protocol can be thought of as request- response architecture. Web browsers, robots, search engines, etc. can be considered as HTTP clients, and a web server acts as a server. [53]

#### **3.2.11.1 Node.js**

Node is an open-source, event-driven, cross-platform, runtime environment which lets developers create several types of server-side tools and programs using JavaScript. [54] This language is one of the languages that is used to implement server-side. Node.js can easily be integrated with ASP.net. Node.js is lets you write your code in JavaScript, however, node.js doesn't use JavaScript for compilation since JavaScript can be limited. So, Node translates written code in JavaScript into C. Node has been developed to increase throughput and scalability in web applications. Node.js lets developers access node package manager (NPM), which provides thousands of packages. So, this way, many developers don't have to write the code from scratch.

#### **3.2.11.2 Angular.js**

AngularJS [55] is a framework fundamentally for dynamic web apps. It can let you use HTML as a template language. AngularJS's data binding and dependency injection allows developers to not have to write any additional code since many templates are already premade. This happens in browser, making web server technology achievable. Dynamic application and static documents are often solved with libraries and frameworks. In short, libraries are collection of functions premade, frameworks are type of implementation of a web application, where code fills in the details. Framework is the manager of sort, and it calls into your code when it requests something app related. AngularJS offers amazing qualities such as data binding, and Dom control structures for reiterating, showing and hiding DOM fragments. AngularJS makes application development easy by presenting a

higher level of abstraction to the developer. More importantly, AngularJS was built with CRUD (Create, Read, update, delete) applications.

## **3.2.12 Application Development**

In this section, a variety of different platforms for application development will be introduced. These include, web applications and native applications, and their differences.

### **3.2.12.1 Web Applications**

Web applications or web-apps are simple programs that make use of web browsers and web technology to perform tasks over the internet. Web applications use a combination of server-side scripts (PHP and node.js) to handle the storage and retrieval of the information as well as the processing of user requests, and client-side scripts (JavaScript and HTML) to either share information with users or collect information from users. Some examples of web applications can include online forms (hospitals, government websites), shopping carts (online retail stores), and email programs such as Gmail, and Yahoo. Applications are usually made with logical sections called “tiers”, where every tier is its own individual layer. This way application is separated into multiple layers. For example, these days, most applications are usually three-layered applications. Moreover, three layers can be categorized by presentation (what users see, otherwise known as front end), application and storage (otherwise known as back end), respectively. Typically, front end is developed to accommodate the user’s need, or the business needs with help of programming languages like HTML, ASP.NET, and many web browsers can extract executable applications from these programming languages. For instance, front end or the client side, usually communicates with a server by sending a request, and then server processes and analyzes this request, and performs appropriate actions such as retrieving the necessary information from the database and sending back the response to the front end. [56]

Nowadays, many users are mobile users. Mobile apps that were developed for desktop browsers won’t work on mobile devices due to the size of the screen. Now, most web apps are responsive to its browsers and the device it is being viewed on. Again, adapting web content to mobile devices through responsive design has two main disadvantages: time and money. Mobile web apps and responsive websites both satisfy the definition of “mobile-friendly”, but responsive web is not the same as adaptive web. While responsive web can self-adapt to any device intuitively, adaptive web has preset sizes in which it is able show. In other words, it may not display correctly in undefined settings. [57]

### **3.2.12.2 Native Applications**

Native apps are applications for specific platforms such as IOS or Android, and can be accessed by clicking on the app’s icon. Apps can use operating system features and other software and hardware that is typically installed on that platform. [58]

Native apps are installed from device specific application stores such as google play or apple's app store. These apps are developed by using programming languages such as objective c for IOS or Java for android operating systems. Native apps perform far better than web applications and have a high degree of reliability. These apps usually store all of the necessary data on the device itself, or data can be saved on a remote server and retrieved when needed. This depends on the app's functionality. For example, if the app's functionality is a sort of a video game, then all the necessary data from the app are usually saved on device itself. [59]

### **3.2.12.3 Comparing Native and Web Applications**

Native apps and web apps both present a substantial number of drawbacks. On one hand, native apps are more expensive in both money and time. Typically, developers must create multiple apps on different platforms to accommodate every user. The cost of app maintenance and app updating is higher for native apps, especially if the app is supported by multiple platforms. In addition, the process of getting the app approved and made available for their app store can be a timely and tedious process. On the other hand, mobile web apps prove to be limited in things it can do as far as features. Web apps are somewhat expensive in terms of maintenance and web application updating. Many times, users are using different web browsers, and it can be tricky to have dedicated web apps perform smoothly over every browser. [60]

### **3.2.13 Amazon Echo**

According to Wikipedia [61], Amazon Echo is a smart speaker developed by amazon.com which was released around mid-2015. The device (Echo) is connected to voice-controlled Intelligent Personal Assistant service name Alexa. Echo has built in voice recognition technology that can interpret human speech dialog. The device is always listening, and monitoring for the wake phrase to be spoken. The wake phrase by default is "Alexa", but it can manually be changed. For example, if user says, "Hi Alexa", the Alexa voice service converts that voice to text and interprets it. The device will separate invocation command (Hi in this case), and then work around some of its standard words to figure out the rest of the command. After processing the command, Alexa responds back to the user with appropriate response, in above case, it would respond something like, "hi <username>, how may I help you". Echo requires wireless internet connection for it to work. Once echo is connected to the home network, it can also be synchronized with other smart devices that are connected to that same network. Amazon echo is preloaded with a lot of commands that user can speak, and Alexa can respond to.

#### **3.2.13.1 Adding Custom Skills to Amazon Echo**

According to the amazon's website, they believe the design phase of skill is very critical. There should be significant amount effort that must go in, in order to create a successful skill. This way users gets what they need from amazon echo. They also believe that

establishing a purpose and user stories, writing scripts, developing workflow are some of proper ways of designing an echo skill so that it is more likely to be successful. Establishing purpose is defined by knowing what people want to accomplish and determining the capabilities of skills as well as benefits. Realizing the stories that can best describe what people can do, will help understanding and help design an effective skill. Using scripts, for example, in interaction between user and Alexa is shown to be great success as well as creating a flow to identify details and variations for the interactions. An example script is presented in *figure 3.2.xvii*.

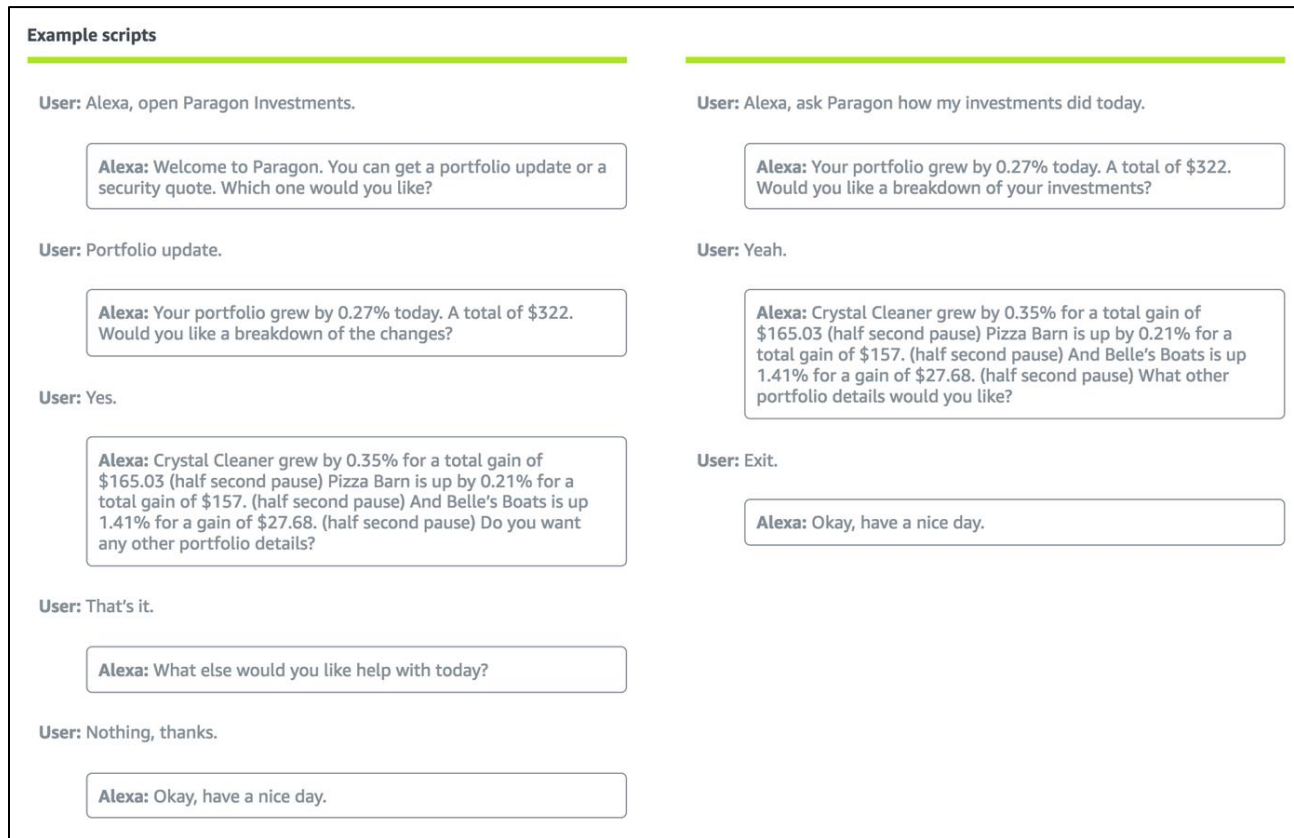

*Figure 3.2.xvii Amazon Alexa Skill Design Process [62] (Permission Requested)*

The Echo can also learn new skills or commands via programming. Amazon has made this feature public, so any developer can create new skills using any programming language if the written code is hosted on a server that the Alexa service can communicate with. [63]

According to Amazon's website, developers should be able to learn, design, build, and launch the skills needed for their project. Amazon has made a few projects in different programming languages for developers to learn and develop custom commands for amazon Echo. The diagram below in *figure 3.2xviii* shows the user interaction flow, and entire workflow for development.

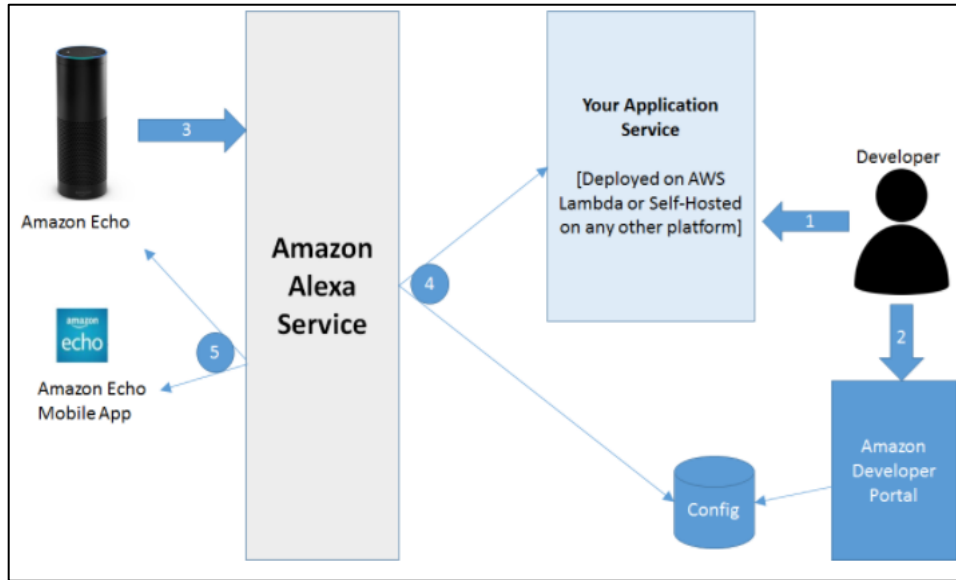

Figure 3.2.xviii Amazon Echo Interaction Flow/Workflow  
 (Courtesy of David Berind, ProgrammableWeb.com)

These next four steps in *table 3.2.v* are necessary to complete to create a custom skill in amazon Echo.

Table 3.2.v Creating an Amazon Alexa Skill

	Step Name	Justification
1	Develop Your Code and Host it on the Server	Design how the user will interact with your service and then write the code to interpret those commands.
2	Configure Alexa Custom Skill	This is done by creating amazon Developer Account, and configure it via Amazon Developer Portal, and skill can be tested as well over there.
3	Interpret Voice Command	Make sure when you speak command to Alexa, Alexa routes request to correct endpoint on the server.
4	Return the Response	The response is then converted to both voice and appropriate format.

## **3.2.14 Software IDEs**

In this Section, Section 3.2.14, software IDEs for the microcontroller will be explored. There are several embedded IDEs available, and as such, knowing about each one will be helpful in the sense that having a preference for a certain embedded IDE might affect the microcontroller that is able to be used. The opposite may be, possibly more likely, that the chosen microcontroller will dictate the use of a certain Embedded IDE. In either estimation, an overview of several IDEs is appropriate as to understand the current field of software IDEs for programming embedded systems. Additionally, it should be pointed out that choosing an IDE for embedded development, is not an independent decision. It is not as if every microcontroller can be programmed with every IDE. This is due to the close proximity of hardware and software in embedded programming.

### **3.2.14.1 Code Composer Studio**

Code Composer Studio is a software IDE made by Texas Instruments. Code Composer Studio offers powerful tools such as an optimizer assistant, which helps you understand how your code performs. This embedded IDE is said to leverage the Eclipse software framework alongside powerful debug tools to come up with an even better development environment for embedded programming. This is useful because for this project, lightweight code is always desired due to the limited nature of whichever microcontroller is chosen. An Instrumentation Trace Module, allows for a high-level view of such as things as interrupts, variable tracing, and statistical profiles. Code Composer Studio also features a large collection of additional software for download and specific tools to allow users to easily see and use software packages for their specific chosen microcontroller, or for a specific task. Code Composer Studio also offers a wide range of debugging functionality. With features such as breakpoints, various stepping functions, and the ability to see register's and variable's current values at every line of code. These debugging features are a powerful asset to a developer as encountering bugs in software development is inevitable. As Code Composer Studio is made by Texas Instruments, naturally, it is designed for Texas Instruments products. That is, to use Code Composer Studio for our embedded programming, the authors must, in effect, choose a Texas Instruments microcontroller. With these considerations in mind, it should be noted that with all of these features, Code Composer Studio can be a bit cumbersome. With more features come more menus, a more complicated UI, and not to mention a larger program. Code Composer Studio itself is a large, heavy application, and in the authors' experience has been prone to crashing and freezing. Code Composer Studio is a powerful embedded software IDE with a few major drawbacks. [64]

### **3.2.14.2 Arduino IDE**

Since an Arduino board will be used, the first IDE considered is the one the Arduino project provides. The Arduino IDE includes a code editor with features such as automatic indenting, syntax highlighting, text cutting and pasting, brace matching, searching and replacing text, and it provides simple mechanisms that require only one click to compile

and upload programs to the Arduino board. The IDE contains a text console, a message area, a hierarchy of operation menus, and a toolbar with buttons for common functions. [65] The text console displays text output by the Arduino Software including complete error messages and other information. The message area displays errors and gives feedback while saving and exporting. The toolbar buttons allow the user to create, open, and save sketches, verify and upload programs, and open the serial monitor. Lastly, the IDE comes with a display of the configured board and serial port in the bottom righthand corner of the window. [66]

Any program written using the Arduino IDE is called a sketch. When sketches are saved, they are saved as text files with the .ino file extension on the development computer. The programs written are written in the C and C++ languages using special rules of code structuring as these languages are the only ones the Arduino IDE directly supports. [65]

When writing the program, the IDE only requires two basic functions. The function `setup()` is for starting the sketch. It is called once the sketch starts after the Arduino is powered-up or reset. The purpose of this function is to initialize everything such as input and output pin modes, variables, and any other libraries that would be needed in the sketch. The second function, `loop()` is used for the main program loop. This function is executed repeatedly in the main program after `setup()` has been called controlling the board until the board is reset or powered off. [65]

Thus, the Arduino IDE offers a very simple and straightforward environment to create the program needed for the smart blackout shades. However, this simplicity may not allow the use of all the features needed for our design. If this is the case, a more capable IDE will be used; however, the Arduino IDE is the IDE that is planned to be used to program the microcontroller.

There is an online IDE that Arduino supports as well. It is the Arduino Web Editor. While it does require a reliable Internet connection, it allows the user to save their sketches in the cloud. Doing this provides the convenience of having the sketches available from any device as well as all of the sketches being backed up by the cloud. The user would always be using the most up-to-date version of the IDE and won't have to worry about the need of installing updates or installing community generated libraries. Over 700 libraries have been written by the Arduino community and they are all browsable in the Library Manage tab. Not having to install convenient libraries for developing the smart blackout shades could prove to be very convenient. [67]

To use the Arduino Web Editor from a web browser, a plugin must be downloaded and installed into it and an Arduino account will need to be created. This allows the user to upload sketches from the browser onto the respective Arduino boards. If the sketches are to be saved to the cloud, an account for that would also be required. However, creating two accounts to use this IDE wouldn't significantly affect the time constraint involved with this project. [67]

The Arduino Web Editor divides the web app into three main columns to allow for the application to be easily accessible. The first column allows for navigation between all of the utilities the IDE provides. It has a collection of all the sketches made by the user located in "Your Sketchbook". It contains pre-made examples that demonstrate the

behavior of the selected libraries and all the basic Arduino commands by only letting the user read these sketches. It contains a list of all the packages that can be included to the current sketch that would allow for extra functionalities. It of course contains helpful links and a glossary for many of Arduino's specific terms as well as the option to customize the look of the IDE. Lastly, it contains a serial monitor which uses the USB cable to allow the user to receive and send data to the Arduino board. The second column displays all of this information in depth and the third column is where all the code is written.

Since the IDE automatically recognizes an Arduino board connected to the user's PC, configures itself accordingly, and is very user-friendly, this IDE could be very likely be used instead of the downloadable IDE provided by Arduino. However, this IDE is subject to possible issues that the downloadable version is not. If the online IDE were to go down when the program was being written, possible information and progress could be lost.

### **3.2.14.3 Eclipse**

While Eclipse is the most widely used IDE for Java, it is able to support the ability to program Arduino microcontrollers. Using plugins, it is able to develop applications in C and C++ which is what the Arduino can read. Unlike the Arduino IDEs, Eclipse's software development kit (SDK) is open-source software and completely free. [68]

To use the Eclipse IDE to program the Arduino board, AVR Plugins for Eclipse must be additionally installed. Once this is completed, Eclipse must then be configured to point to the IDE location and the Arduino Core Library must be obtained. The Arduino core library can be obtained by getting an existing binary from an Arduino IDE project, compiling the library directly into the project being worked on, or by compiling one's own library file. Lastly, Eclipse will have to be configured for the Arduino core library. [69]

As for setting up the preferences for an Arduino based project in Eclipse, that requires a large amount of steps that adjust the settings for the compiler. This makes setting up to write the program on the Arduino seem like a larger hassle than necessary. There could be some issues of using the "new" and "delete" commands in C++ due to the Arduino having limited memory. Most likely, the program will be written in C. However, if Eclipse offers more options that make writing the program easier in the long run, this IDE would be used instead.

### **3.2.14.4 Visual Studio**

Visual Studio is an IDE developed by Microsoft that is usually used to create computer programs for Microsoft Windows along with web sites, mobile apps, web services, and web apps. Since our group plans to use a web app that would be utilized by the phone, Visual Studio could be an IDE used to develop both the web app and microcontroller. The code editor for this IDE supports code completion using IntelliSense for variables, methods, functions, and loops, as well as syntax highlighting. [70]

For Visual Studio, it uses a plugin called Visual Micro that allows Arduino compatible cross-platform programs. As long as the arduino.cc rules are adhered to, the code that is created will remain Arduino compatible. Visual Micro contains the Arduino compatible library and board managers to allow the programmer to discover and download the compatible Arduino boards and libraries. [71]

Since this IDE follows the common standards created by various hardware manufacturers (including arduino.cc), newly released hardware will be able to be programmed with Visual Micro without the need for any software updates. Visual Micro is made to look similar to the Arduino IDE. However, it allows more advanced users of the Arduino have a bigger range of options when programming. This is done by allowing Arduino's simple, yet restricting, rules to be broken when desired. [71]

Since Visual Studio allows for shared cross-platform projects, developers can take advantage of using cross-platform code to be created in smaller projects which are then automatically combined with the program code during build. Source control and version control are very easy due to this IDE allowing shared projects and shared libraries to be accessible from any location. There is a Pro version of Visual Micro that allows the code to be more easily visualized by including a unique USB/Wi-Fi debugger; however, this seems like an unneeded expense in developing the program for the smart blackout shades. [71]

### **3.2.14.5 Atmel Studio 7**

Atmel Studio 7 utilizes the 2015 version of the Visual Studio Shell. However, it tries to improve the performance of the IDE when working with large projects as well as making the look and feel of the IDE more user friendly. One of the key features that Atmel Studio 7 that was created in the Arduino development environment utilizes a seamless one-click import of projects. This IDE allows fine-tuning and the debug of imported projects. [72]

Due to the unfamiliarity of this IDE, it most likely won't be utilized in the development of the program for the smart blackout shades. However, if this IDE does provide a way to fine-tune the program beyond the Arduino's IDE, it could be used if enough time remains to learn the utilities provided by this IDE.

## **3.3 Strategic Components and Parts Selection**

In this section of the document we will go over each required part for the project in detail. This entails a detailed comparison of different parts and models, and a final part selection with a convincing justification. Some of the important characteristics to be compared when choosing parts are cost, size, and performance.

### 3.3.1 AC-DC Converter

The AC-DC Converter will involve two major components: the transformer and the rectifier diodes. In this section various models of these components will be compared, and ultimately a decision will be made as to which model will work best for this project.

For this project, it has been decided that a 120:24 step-down transformer is desired. This will allow us to step down a normal household outlet 120-volt 60 Hz signal into a 24-volt waveform that can later be rectified and regulated to the necessary DC voltages required to power the various system components. The power required to operate the system should be considered, as well other factors such as the size and price of the various models. This is shown in *Table 3.3.i*.

*Table 3.3.i Transformer Comparison [73], [74], [75]*

<b>Transformer</b>	<b>VA Rating</b>	<b>Volume (in<sup>3</sup>)</b>	<b>Price</b>
White Rodgers T4F03	40	19.57	\$8.95
Altronix TP2450	50	20.33	\$22.98
ELK TRG2440	40	24.96	\$11.80
Triad Magnetics F8-24	100	17.65	\$20.33

The Altronix TP2450 and the ELK RTP2440 both come in wall mounted packages, unlike the White Rodgers T4F03. This wall mounted package is not ideal for this application because it would be preferred to have the window shades system be fully contained in its housing. The Triad Magnetics F8-24 is different from the other transformers explored because it is a through hole component. The Altronix TP2450 also allows for 2A while the White Rodgers and ELK are only rated for 1.6A output. Fortunately for this project 40VA should be sufficient to power the system. With this being the case, the consideration turns to size and cost. While the White Rodgers T4F03 and the ELK TRG2440 are both less expensive than the Triad Magnetics F8-24, the F8-24's convenient package and smaller size are highly desirable. While the 100VA may seem excessive for our application, but it should be noted that this allows flexibility for a variety of motors. In addition, for this component a premium has been placed on the package and size. This is because we want to keep our system small and self-contained in the housing, as explained before.

The other major component required in the AC-DC converter is the diode to be used in the bridge rectifier. The major considerations in diode selection, for this application, are the current rating and the forward voltage. This is shown in *Table 3.3.ii*.

*Table 3.3.ii. Rectifier Diode Comparison [76], [77], [78]*

<b>Diode</b>	<b>average rectified current (A)</b>	<b>Forward Voltage (V)</b>	<b>Price</b>
1N4001	1.0	0.93	\$0.14
MUR160RLG	1.0	0.875	\$0.45
1N5391	1.5	1.1	\$0.18

These diodes meet the minimum project requirements for the bridge rectifier. For this application, a low forward voltage is desired. The MUR160RLG greatly exceeds the requirements for this application, and this is reflected in its price. The MUR160RLG is a poor choice for this application and will not be chosen. The assumption has already been made that 1.5A output for the transformer is sufficient, so a natural assumption is that the average rectified current should be similar. The 1N5391 meets this requirement, but its forward voltage is 8 mV larger than that of the 1N4001. The forward voltage being considered, 8 mV is not an egregious difference and thus a premium is placed on the average rectified current. Thus, the higher price of the 1N5391 becomes justified and becomes the diode of choice for the bridge rectifier.

Another option arises of simply purchasing a packaged bridge rectifier. There exist integrated circuit forms of bridge rectifiers. Several packaged bridge rectifiers will now be compared, and ultimately the selected packaged bridge will be compared to the discrete diode approach. This is shown in *Table 3.3.iii*.

*Table 3.3.iii. Bridge Rectifier Comparison [79], [80], [81] [82]*

<b>Bridge Rectifier</b>	<b>average rectified current (A)</b>	<b>Forward Voltage (V)</b>	<b>Price</b>
S1VB60	1	1.05	\$0.49
ABS210	2	1.1	\$0.44
DF206ST-G	2	1.1	\$0.66
D10XB60	10	1.1	\$3.13

The D10XB60 while impressive, does not reflect a realistic choice given its large price. A rectified current of 10A is simply excessive for this application. While the S1VB60 has a low forward voltage of 1.05V, the average rectified current of 1A is simply not large enough for this application. This leaves the ABS210 and the DF206ST-G, which match each other in forward voltage and average rectified current. However, the ABS210 is a full \$0.22 cheaper, and thus becomes the bridge rectifier of choice.

The discrete diode approach with the 1N5391 and the single packaged bridge rectifier approach with the ABS210 are nearly equal in cost. In addition, the design work involved in the discrete diode is minimal. The choice comes down to whichever approach will integrate itself better into our power systems board. Since this board has yet to be finalized, a decision on the most appropriate approach cannot be effectively made now.

A flyback converter topology will also be examined, and thus, a flyback controller will be selected. The flyback controllers presented in the WEBENCH generated designs in Section 3.2.1 will be compared as to arrive to an appropriate flyback controller, and more generally, an appropriate flyback converter topology. This is shown in *Table 3.3.iv*.

*Table 3.3.iv Flyback Controller Comparison [83], [84], [85]*

<b>Flyback Controller</b>	<b>Control Method</b>	<b>Duty Cycle Max (%)</b>
UCC28630	Current	70
UCC2813	Current	100
UCC28740	Current	99

Ultimately, the flyback controller must be considered in the context of its entire design. Unlike the prior component selections, the choice of flyback controller has greater consequences in the context of design. When choosing another component, for example a rectifier diode, certain parameters are sought after, such as a certain current rating. Then factors such as price and size are considered. In the case of the flyback controller selection; the selection dictates the entire design of the AC-DC converter. As can be appreciated from the topology comparisons in Section 3.2.1, the controllers in consideration require designs that vary greatly. Such that in this selection process, those presented designs make a considerable, if not the only, consideration in the selection of the flyback controller. It is such that the UCC28630, and its subsequent topology, is selected. This controller, but more accurately, its complete topology, presents an acceptable efficiency at a reasonable complexity. It should be noted that at this point in the design process, it is unclear whether the increased efficiency of a flyback controller is at all necessary, or if a simple AC-DC rectifier will be sufficient for this application. Further testing and considerations are necessary to come to a decision, but for the sake of thoroughness a flyback controller is selected to be potentially prototyped and tested.

### **3.3.2 Batteries**

For our project, to avoid the difficulties and dangers that come with using unprotected lithium-ion batteries, we decided to use a battery pack with a protection circuit already installed. This will avoid the need for extensive circuitry including input and output current limiting, overcharge/over-discharge protection, and cell balancing. The battery packs to

be explored are built and tested by the company Tenergy<sup>®</sup>. They are precisely measured and balanced, and then put through their extensive quality control tests. Since the necessary operating voltage of the motor is yet to be determined, a few different available battery packs are compared below.

When comparing these battery packs, the different specs to be explored include nominal voltage, fully charged voltage, fully discharged voltage, current discharge rate, number of cells, size, price and capacity. In *table 3.3.v*, various battery pack specs are compared. These battery packs range from 7.4V to 14.8V nominal voltage, and vary between 2 to 8 cells. The nominal voltage of the pack is figured from 3.7 volts per cell, which will actually vary with charge/discharge. The cells are usually rated to be at 4.2V fully charged, and 3.0V full discharged. Therefore, for a 14.8V battery pack, it will actually have a range of 12.0V to 16.8V.

*Table 3.3.v Battery Comparison [86], [87]*

Model	Nominal Voltage	Discharge Current	Number of Cells	Capacity	Dimensions	Price
31091	14.8 V	4 A	4s	2200 mAh	263 x 25 x 25 mm	\$42.59
31098	14.8 V	5 A	4s	2600 mAh	131 x 36 x 23 mm	\$46.50
34239	14.8 V	5 A	8 (4s2p)	5200 mAh	261 x 38 x 23 mm	\$89.99
31012	11.1 V	4 A	3s	2200 mAh	70 x 55 x 18 mm	\$26.99
31061	11.1 V	3 A	3s	2200 mAh	196 x 25 x 25 mm	\$36.59
31099	11.1 V	3 A	6 (3s2p)	5200 mAh	198 x 36 x 23 mm	\$67.59
31003	7.4 V	4 A	2s	2200 mAh	72 x 38 x 19 mm	\$19.99
31495	7.4 V	5 A	2s	2600 mAh	70 x 38 x 27 mm	\$27.59
31044	7.4 V	5 A	4 (2s2p)	5200 mAh	135 x 37 x 21 mm	\$44.99

When looking at the number of cells column, it is worth noting that the ‘s’ and ‘p’ after the numbers stand for series and parallel. For example, the 8 cell pack has 4 cells in series to provide the 14.8V, and then another 4 cells in series, in parallel with the other. This helps provide extra capacity to the battery packs, while obtaining the same nominal voltage. While the 8 cell (4s2p) battery pack would be able to provide us with a constant 12V and plenty of capacity, it is quite expensive and fairly large/heavy, therefore is probably not realistic for our design. For size and space reasons, it would make sense to use a battery pack with 4-6 cells. In order to give our batteries the capacity that we would like, it would make the most sense to have some of the cells in parallel, to essentially double the lifetime of the battery pack. Since this is the case, it has been determined that we will test the speed and torque versus the input power of the motor, to determine what our maximum voltage will need to be. From there we would ideally be able to decide on using a 11.1V or 7.4V pack, in order to save space, and provide some extra battery lifetime.

### 3.3.3 PV Panel(s)

The photovoltaic panel is an integral part of this project. It is the system's main source of power, and as such, must be capable of fully supplying the system's required power consistently. A poor choice in photovoltaic panel would be disastrous to the progress of this project, and as such, a great deal of thought has been placed into the selection of an appropriate photovoltaic panel for this project. The relevant considerations in photovoltaic panel selection are multifaceted, in that they require both electrical and mechanical considerations. The two major electrical considerations in choosing a photovoltaic panel are the output voltage and power rating. A mechanical aspect also becomes important, in that this system will be mounted in a window frame. This means that the size of the photovoltaic panel is an important factor to consider. The form factors of the photovoltaic panels to be considered will be explored in so much as the panel's footprints on the window frames that they will be mounted onto. For the purposes of this project it has been determined that a 30W solar panel should be sufficient to power the entire system consistently. Of course, if this 30W is later deemed insufficient for the needs of this project, a new more appropriate photovoltaic panel will need to be selected. As such a determination cannot be made until thorough testing of the system in its entirety has been completed, photovoltaic panels that fit the expected criteria of 30W will be explored in the remainder of this section.

*Table 3.3.vi Solar Panel Comparison [88], [89], [90], [91]*

<b>PV Panel</b>	Aleko 30W 12V	Renogy 30W 12V	SolarTech 30W 12V	Dasol DS- A18-30
<b>Operating Voltage (V)</b>	18.2	17.5	17.3	18
<b>Operating Current (A)</b>	1.65	1.71	1.77	1.67
<b>Open Circuit Voltage (V)</b>	22	21.6	21.9	22.3
<b>Dimensions (In)</b>	26x15x3	23.8x13.5x1.0	26.2x16.2x0.98	25.6x13.8x1.0
<b>Price</b>	\$59.00	\$54.00	\$61.60	\$77.78

The panels presented in *Table 3.3.vi* are all 30W 12V panels. As these are the most broadly relevant parameters that are desirable to explore, the field of solar panels has been reduced to these four options. It can be noted that the four panels being explored all have rather large dimensions when compared to a window. Of course, there are smaller panels, but because the panel to be selected is being considered in the context of the prototyping stage, it was determined that a functional, inexpensive panel was preferable to a competitively sized one at a much higher price. At the prototyping stage, the functionality of the system is the primary quantity being explored. If at a later time in this project's development, the size of the panel becomes a large issue than this panel selection will be revisited, albeit with an increased sensitivity to dimensions, and a

markedly less prudent view on price. But, as this is not yet within the scope of this section, these panels will be continued to be examined in the context of the prototyping and testing stages. For our application, the main concern is being able to pull enough current from the solar panel. With this consideration, the Aleko 30W and the Dasol DS-A18-30 are not considered, as their operating currents are reduced as compared to the other two panels. Additionally, the price of the Dasol DS-A18-30 is not seen to be justified as compared to the other panels. While the SolarTech 30W 12V does provide the largest operating current, it is also the largest of the panels being considered. Although as mentioned previously, that size is not a main concern at this point, but with only a 7 mA increase over an increase of more than 100 square inches, size can be considered. With these considerations in mind, the Renogy panel is the chosen panel. This panel offers a large operating current, a relatively small size, and at a reasonable price point.

As the testing and prototyping progresses it may become apparent that the selected panel will not be suitable for our application. If this is the case then more panels will be examined, and a better solution will be chosen, but as the testing and prototyping processes are still ongoing; these decision cannot yet be made. With this in mind, it should be noted that the panel selected in this section may not necessarily be the solar panel used in the final iteration of this project.

### 3.3.4 Voltage Regulators

Several different voltage regulators are required to supply various voltages for this project. A separate regulator will be used for the microcontroller, LEDs, and the motor, as they all require different voltages to operate. These regulators are important for the system's electrical components to behave as expected. Without proper regulation, nothing will work. Additionally, at least reasonably efficient regulators are desired for this application. Power is a far reaching concern in all aspects of this system, and the regulation stage is no different. Several voltage regulators will now be compared as to find an appropriate regulator that will fit the specific needs of this project.

The first regulators to be explored will be the 12V regulator for the motor. Since the motor requires a large current of 3A, the regulator output current should be taken into great consideration. Various 12V linear regulators will now be compared in *Table 3.3.vii*.

*Table 3.3.vii. 12V Voltage Regulator Comparison [92]*

<b>12V Voltage Regulator</b>	<b>Output Current (A)</b>	<b>Dropout Voltage (V)</b>	<b>Max Vi (V)</b>	<b>Price</b>
LT1084	3	1.3	25	\$11.29
LT1085	4	1.3	25	\$8.04

There were very few choices in 12V regulators with maximum current outputs of 3A or more. The two regulators are manufactured by the same company, linear technologies,

and are part of the same series. That being the case, the LT1085 has a lower price, while also having a 4A maximum output current which would allow for a 1A margin for driving the motor. These factors make the LT1085 the better choice between these two regulators.

With the special current considerations of the 12V regulator, the remaining regulators can be compared together since there are no exceptional specifications for either of the remaining voltage regulators. This is shown in *Table 3.3.viii*.

*Table 3.3.viii. Voltage Regulator Comparison [93], [94], [95], [96]*

<b>Voltage Regulator</b>	<b>Output Current (A)</b>	<b>Dropout Voltage (V)</b>	<b>Max (Vo - Vi)</b>	<b>Price</b>
LM78xx	1.0	2.0	35	\$0.85
L7800	1.5	2.0	35	\$0.86
LM1084	5	1.3	25	\$0.95
LD1117A	1.0	1.15	15	\$0.90

Four voltage regulators have been chosen as potential parts. The LM78xx is a popular choice, but for this application its 1A output current, which is fairly small, may not be acceptable. This could prove to be a limitation in practice, so the LM78xx will likely not be chosen. The LD1117A also has an output current of 1A, but has the lowest dropout voltage among the voltage regulators being examined. The L7800 and LM1084 both have acceptable Max voltage differentials and dropout voltages. The LM1084's output current of 5A sets it apart from the L7800, but for this application 5A should not be necessary. Considering these various factors, the LD1117A should be acceptable for prototyping purposes, and is the most suitable voltage regulator for the purposes of this project at this point. Should the 1A output current not be sufficient, the L7800 would be a natural choice. Further testing will be necessary to make a final decision.

The various voltage regulators examined should be sufficient to supply the necessary regulated voltages to all of the required electronics components to be used in this project.

### **3.3.5 Motor**

In this section, a few different motors will be compared. It was decided that, for our project, we will look primarily for motors that include an encoder already built in. This makes for much easier position tracking without the need for developing an encoder/encoder board. The motors mentioned below are sold by the company RobotShop inc., which specializes in distributing parts for robotics and control.

When comparing motors, it is important to look at parameters such as RPM (revolutions per minute), minimum (no load) current, maximum (stall) current, operating voltage, rated torque, dimensions, weight, and price.

The three motors that will be compared in *table 3.3.ix* are the FIT0186, a 12V DC, 251RPM brushed motor with a hall effect encoder, the FIT0277, a 12V DC, 146RPM, low noise brushed motor with a hall effect encoder, and the PGM45-26, a 12V DC, 90 RPM brushed motor, also with a hall effect encoder. Since all of these motors are brushed, it will allow the same method of control no matter which one we choose. A few of the specs mentioned above that are pertinent to our project will be compared.

*Table 3.3.ix Motor Comparison [97], [98], [99]*

Motor	Rated RPM	No Load Current	Stall Current	Operating Voltage	Torque	Diameter	Price
FIT0186	204	0.35 A	7 A	12V DC	45oz-in	37mm	\$29.00
FIT0277	109.5	0.23 A	3.6 A	12V DC	139oz-in	28mm	\$45.99
PGM45-26	90	0.25 A	10 A	12V DC	99.11oz-in	42.2mm	\$38.72

Since we do not need a fast motor, the FIT0186 can essentially be crossed off the list. Although it has a great price, it needs a relatively high current and in turn produces a small amount of torque. The PGM45-26 provides plenty of torque at a lower speed, but has the highest stall current at 10A which our power system will likely not be able to provide. It is also the thickest in diameter, which is limiting in our shade roller design, in which the motor will fit inside of the shades shaft. For these reasons, we've decided to go with the FIT0277 motor. Although it is the highest priced of the three, it offers the most torque at the lowest operating current, while also being the smallest in diameter. It is also worth noting that the other motors produce much more noise than the FIT0277, from the customer reviews it is read that the motor is near silent, which is why it is marketed as 'low noise.' This is a great feature as it will help us meet our requirement of low operation noise.

### 3.3.6 Motor Driver

As mentioned before, in *section 3.2.5*, driving a DC motor in both directions requires an H-Bridge circuit. These circuits are available on the market in the form of many different integrated circuits. A number of these H-Bridge integrated circuits will be compared in this section. From research, it is very important to be mindful of the heat dissipation of the H-

Bridge. Most of the integrated circuits produce a lot of heat from the fast switching of transistors when driven with a pulse width modulation input. It is necessary to drive the motor with a PWM input to vary the speed at which it will spin. For our application, it will not really be necessary to vary the speed, however we do want the ability to program it to spin at a certain speed. We don't want the shades to be racing down as fast as possible, but we also don't want them to be drawn extremely slow. Since the motor speed will vary based on the load applied, and we do not know the exact weight and size of the shades, having this ability to vary speed will help us fine tune the speed at which the shades draw, after a fully built prototype is put together next semester.

Some important things to consider when choosing an H-Bridge motor driver include, operating voltage range, maximum output current, temperature range, number of external components required, available package size, and price. The three motor drivers that will be compared in *table 3.3.x*, are the Texas Instruments DRV8829 5A, 45V Single H-Bridge Motor Driver, the Infineon Technologies TLE 5206-2 5-A H-Bridge for DC-Motor Applications, and the STMicroelectronics L6201 DMOS Full Bridge Driver. All three of these H-Bridge circuits have built in over-temperature protection (thermal shutdown), over current protection, and short circuit protection.

*Table 3.3.x Motor Driver Comparison [100], [101], [102]*

Model	Voltage Range	Constant Current Output	Temperature Range	Number of External Components	Package Size	Price
DRV8829	8.2V to 45V	3.5 A	-40 to 150 °C	11	28-HTSSOP	\$3.81
TLE5206-2	5.3V to 40V	5 A	-40 to 150 °C	3	TO220-7-12 TO263-7-1 DSO-20-12 TO220-7-11	\$4.21
L6201	12V to 48V	1 A	-40 to 150 °C	9	SO20 PowerSO20 Powerdip 18 Multiwatt 11	\$7.00

Since, as mentioned before, we want to explore the different power vs speed ratio of our motor, we want to be able to test the motor with an input voltage anywhere from 12V down to about 6V. That being said, since the STM L6201 has a relatively high price, and a high voltage range starting at 12V, it will not be suitable for our applications. The TI DRV8829, while being the cheapest, can still not provide us with a low enough input voltage to choose a 7.4V battery pack. Therefore, the TLE5206-2 seems to be the best choice. It has an acceptable voltage range for our testing, the highest allowable constant current output, and as a bonus, it requires the least number of external components to integrate into our system.

### 3.3.7 IR Remote Control

The Infrared remote control requires three main components: a microcontroller, an IR LED, and an IR receiver. The microcontroller must be capable of generating the desired pulses, the IR LED must be capable of transmitting the generated pulses an appropriate distance, and finally the IR receiver must be able to detect the pulses from the IR LEDs distance. In this section these three major components will be explored. The first being, the microcontroller. This is shown in *Table 3.3.xi*.

*Table 3.3.xi Microcontroller for IR Remote Control Comparison, [103], [104], [105]*

<b>Microcontroller</b>	<b>I/O Pins</b>	<b>Power</b>	<b>Price</b>
Arduino Nano	30	19 mA	\$22.00
MSP430 LaunchPad	24	330uA	\$9.99
Adafruit Trinket	5	0.2 mA	\$6.95

Three microcontroller options are presented: Arduino Nano, the MSP430 Launchpad, and the Adafruit Trinket. All of these are on the simple side of microcontrollers, as the infrared remote control microcontroller is not very intensive in practice. All that is required for the microcontroller is to send pulse commands to the IR LED to be transmitted. All three of the configurations explored come with pin layouts already, as for the prototyping process, manufacturing a board at this point is not desired. All three of the microcontrollers can be programmed using Arduino, in the case of the MSP430 in Energia. While the MSP430 can also be programmed in C, or directly in assembly in TI's CCS. The price of the MSP430 is less than half of the price of the Arduino Nano, which is a big consideration, and the Adafruit Trinket is nearly half the price of the MSP430. Cost, and power consumption are significant aspects to be considered in the IR remote control application. Additionally, the Adafruit Trinket is a lower power solution, which is desirable for this embedded application. The Arduino Nano does not have the most pins, but this application does not require nearly as many pins as the Arduino Nano and the MSP430 Launchpad boards provide. Considering these various factors, for prototyping, the Adafruit Trinket is the most attractive microcontroller for the IR remote control.

The next component that is necessary for the IR remote control is the IR LED. That is, the LED mounted on the remote that will transmit the pulse codes to the IR receiver on the main housing. It is important the selected IR LED have sufficient radiant intensity to reach the IR sensor. Several IR LEDs will now be examined. This is shown in *Table 3.3.xii*.

Table 3.3.xii IR LED Comparison [106], [107]

IR LED	Radiant Intensity (mW/sr)	View Angle (deg)	Pout (mW)
IR333-A	85	20	150
YSL-R531FR1C	--	60	90

Two IR LEDs will be compared. The IR333-A has a narrow beamwidth with a good radiant intensity. The YSL-R531FR1C datasheet did not provide radiant intensity information, and has a much wider beamwidth. For this application, a narrow beamwidth is desirable. The Power out of the YSL-R531FR1c is also lower than that of the IR333-A. That being said, proceeding with an IR LED that the manufacturer lists no irradiance information for is a dangerous proposition. For the remote control a narrow beamwidth of high intensity is desired because the remote control will be pointed directly at the IR receiver. In addition, the wide beamwidth of the YSL-R531FR1C is undesirable. Even though, the power out of the IR333-A, it is still the better choice of the two IR LEDs.

The final major component for the IR remote control is the IR receiver. It should be noted that the IR LED and IR receiver must be selected in conjunction with each other. As the IR led is at a certain wavelength must match that of the IR receiver to be properly demodulated. This consideration has been taken, and as such, only IR receivers that are compatible with the chosen IR LED, the IR3330-A, are to even be considered in this section. This is shown in *Table 3.3.xiii*.

Table 3.3.xiii IR Receiver Comparison [108], [109]

IR Receiver	Supply Voltage (V)	Supply Current (mA)	Power Consumption (mW)
TSOP38238	2.5 - 5.5	3	10
IS471F	4.5 - 16	3.5	250

Two IR receivers are considered now. The IS471F generally requires a higher supply voltage, higher supply current, and with a greater power consumption as compared to the TSOP38238. As with most systems in this project, reducing the operating power is always a great consideration. Especially in the IR remote control system, as the size of the system, which includes the size of the batteries required, is of an even greater importance. With these considerations in mind, the TSOP38238 is the obvious choice between the two.

These components outline the three major components required to prototype the IR remote. With these selections in microcontroller, IR LED, and IR receiver, the IR remote control system should be ready to prototype. It should be noted that the selections

outlined in this section apply primarily to the acquisition of parts for prototyping purposes. A further investigation into parts acquisition will be made in a later section of this document, for the final board layouts, once a thorough testing and examination of the prototyped systems, constructed of the components outlined in this section, can be completed.

### 3.3.8 PIR Motion Detector and Lens

In this section, the various parts that make up the PIR motion detector board, and the lens will be discussed.

#### 3.3.8.1 Motion Detector

For this application, a PIR motion detector that works with the project’s specified engineering requirements, and in addition, is also very low power. At this time, the project is currently in a prototyping stage, and as such, various components requisite for the prototyping of the PIR motion detection system will be explored. The parts described may be the final components used, but again, it should be noted that an emphasis is placed on the selected components in the context of prototyping. Several PIR sensors will be examined in *Table 3.3.xiv*.

*Table 3.3.xiv PIR Sensor Comparison [110], [111], [112]*

<b>PIR Sensor</b>	<b>Supply Voltage (V)</b>	<b>Current drawn (mA)</b>	<b>Range (ft)</b>
555-28027	3.0 - 6.0	12	15.0 - 30.0
RB-lte-116	4.5 - 20.0	--	20
OpenPIR	3 - 5.75	3	6.0 - 16.0

All of the PIR solutions put forth in *Table 3.3.xiv* allow for varying levels of customizability, as well as flexibility in integrating them into projects. For example, the RB-lte-2116 does not offer any customizability in range. This is undesirable for this project, because as has been discussed throughout this document, a great deal of emphasis has been given to ensure that the completed project offers a great deal of flexibility in practice. Additionally, the RB-lte-116 manufacturer’s datasheet did not provide data for active current drawn. As previously mentioned, power is of importance in the PIR sensor, and as such, it would be imprudent to select a component without knowing such information. These factors effectively disqualify the RB-lte-116 from any serious consideration. Parallax’s 555-2807 has a long range, up to 30 feet. The range on this sensor can be adjusted, but only with the use of a jumper. That is, there is only a “short range” and a “long range” setting, which compared to Sparkfun’s OpenPIR sensor, which allows the range to be adjusted with a potentiometer, is much more limiting in practice. The OpenPIR sensor also has the advantage of having a very low active current draw of 3 mA. This is four times less than the 555-28027. While, the range of the OpenPIR sensor is half that of the 555-28027, the range of 16 ft should be sufficient for this project. Considering all of these factors, the OpenPIR sensor is the PIR sensor of choice at this stage in the prototyping process.

It should be noted that the selected PIR motion detection system to be prototyped and tested will not necessarily be the same PIR motion detection board that will be examined and tested. This part selection can, and should, be viewed as more of a development board selection that will be used to provide a better understanding of the PIR sensor and controllers of the selection. One consideration for this change would be that of size. With this being said, it may also be prudent to use the selected PIR sensor as is. An appropriate decision will be made after the prototyping stage, once the board and its sensors, have been thoroughly examined and tested in the greater context of the entire project.

### 3.3.8.2 Fresnel Lens

To obtain an excellent diffraction angle for our motion detection, we will use a Fresnel lens. A variety of these lenses are available at [fresnelfactory.com](http://fresnelfactory.com). Most if not all security system motion detectors use a PIR sensor and a Fresnel lens. Depending on the lens size and concavity, the diffraction angle and effective distance can change. It is important for the lens we choose to blend in with the housing and not be obtrusive and obvious, therefore, we've decided to limit our search to primarily black/dark lenses.

Some things to compare when selecting a lens include; focal length, viewing angle, detectable distance, overall size, and price. The focal length is the length in which the PIR detector must be placed in order for the lens to diffract properly. The viewing angle is the angle/shape at which the motion will be detected. A couple different models of lenses will be compared in *Table 3.3.xv*. These include, the PF20-06015, the PF23-11012, the PF23-6020, the PF305-8324, and the PF297-79810. Each of these lenses has unique characteristics that make them valuable in different applications.

*Table 3.3.xv Lens Comparison [113]*

Model	Focal Length	Viewing Angle	Detectable Distance	Overall Size	Price
PF20-06015	20 mm	60°	15m	Circular – 35mm diameter	\$1.55
PF23-11012	23 mm	110°	12m	Rectangular – 56.7 x 35.7 mm	\$1.55
PF23-6020	23 mm	60°	20m	Rectangular – 39 x 25 mm	\$1.55
PF305-8324	30.5 mm	83°	24m	Rectangular – 61 x 42.7 mm	\$1.55
PF297-79810	29.7 mm	79.8°	10m	Rectangular – 58 x 45 mm	\$1.55

Since all of these lenses from Fresnel factory are the same price, it makes it easier to choose one that can be catered to our necessary specs specifically. That being said, in a typical room, it would be necessary to have a large viewing angle. Therefore, the PF20-

06015 and the PF23-6020 will probably not be suitable for our application. At first look the PF23-11012 with a 110° viewing angle seems the best, however, it seems to lose a lot of range as a tradeoff to having a large viewing angle. Therefore, the PF305-8324 is the lens that we will choose due to the fact that it has a large viewing distance and a well-rounded viewing angle.

### 3.3.9 Microcontroller/Wi-Fi Chip

The microcontroller in our system will be used to send and receive commands from the cloud server, web application, the IR remote and the PIR motion sensor. It will also control the signal to drive the motor, and LEDs. There are a number of things to consider when selecting a microcontroller. These can include, number of I/O ports, memory amount/type, software IDE compatibility, cost, power constraints, product availability, etc... For our project, since we need Wi-Fi connectivity, it has been decided to use a System on Chip (SoC) wireless connected microcontroller. A variety of these types of microcontrollers exist on the market, and a few of them will be compared in this section.

The following three different models that will be compared in *table 3.3.xvi*. The Atmel ATSAMW25, which is based on the ATWINC1500 2.4GHz Wi-Fi SoC, combined with the ARM Cortex M0+ based microcontroller. The STMicroelectronics SPWF04SA, which is built with a STM32F439 using ARM Cortex M4 architecture, as well as providing a 2.4 GHz IEEE 802.11 b/g/n transceiver all on the same chip. The ESP-12s, which is based on the Espressif ESP8266 smart connectivity platform, an all in one microcontroller and self-contained Wi-Fi networking solution. The ESP-12s contains the ESP8266 chip as well as an onboard antenna.

*Table 3.3.xvi Microcontroller Comparison [114], [115], [116]*

MCU SoC	Number of I/O	Memory	Software IDE	Dimensions (mm)	Price
ATSAMW25	31	256KB embedded Flash and 32KB SRAM	-Atmel Studio 6 -Arduino IDE	33.8 x 14.9 x 2.2	\$18.92
SPWF04SA	19	256 KB SRAM and 2 MB embedded high-speed Flash memory	-STM32Cube	26.9 x 15 x 2.3	\$15.75
ESP-12s	10	4 MB Flash memory	-NodeMCU Lua -Arduino IDE	24 x 16 x 3	\$6.95

Our project requires 4 digital inputs, 4 digital outputs, and 1 analog input. This calls for a total of 9 available I/O pins. That being said, the ESP-12s module will suffice. Also, due to the low cost and size of the module, and the plethora of support available online, this makes the ESP-12s a good choice for our main microcontroller unit. Some added benefits are that the ESP-12s sports a good amount of programmable flash memory, and is programmable with C language in the Arduino IDE.

### 3.3.10 LEDs

LEDs will be placed above our window shades to give lighting options to the user around time of darkness (usually at night.) This can be considered an alternative lighting option. It is energy-efficient and the brightness level can be controlled directly from the user’s phone. User can have full-control. Moreover, users will be able choose a particular LED color from the available color palette. Color palette is set of colors with all shades included all in one place. Below is a good example of a functionality that will be implemented in our web app, that users will be able to use to choose particular colors for their LEDs. Please note that not all of the colors displayed below will or can be used for LED lighting. This is shown in *figure 3.3.i*.

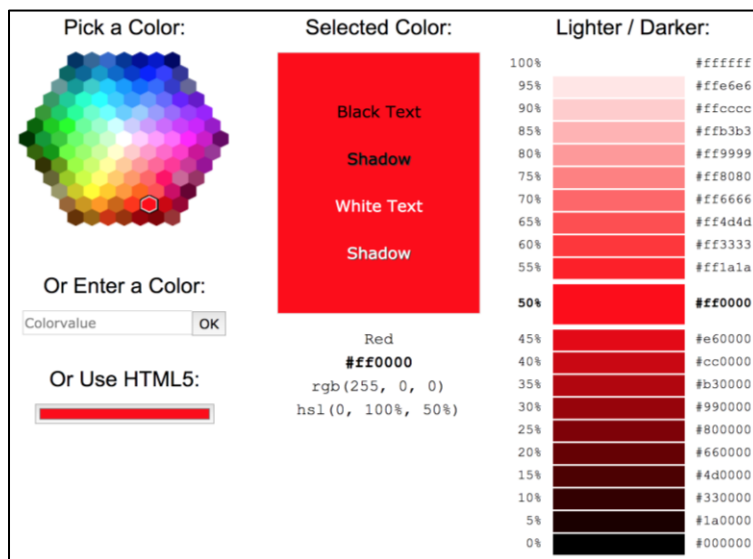

Figure 3.3.i LED Color Palettes [117] (Permission Requested)

In order to illuminate our shades to different colors we intend on using an LED light strip across the top of the shade pointing down. This will allow the user to create a mood with different color lights, while the shades are down. Since they are blackout shades, this can ideally be done during the day or at night. There are a number of different types of LED strips, all based on the same essential RGB (Red, Green, Blue) or RGBW (Red, Green, Blue, White) LED. Usually spaced out at an interval from 30 – 120 LED’s per meter. The

LED's can be driven via analog or digitally, depending on how the manufacturer has the LED's wired. With the digital control, there is usually some sort of chip inside the LED or LED strip, that allows the user to address each LED individually by sending data. For analog control, a simple voltage is applied to each individual LED lead. This voltage can be controlled using a MOSFET to vary the intensity to each LED color; red, green, blue, white, or any mixture of the four.

A few different types of LED strips will be compared in *table 3.3.xvii* below, all of which are available from adafruit®. Adafruits NeoPixel LEDs are digitally controlled, and very intuitive. However require very specific timing on the data line. Conversely, Adafruits DotStar LEDs have a higher timing tolerance and can be driven from pretty much any microcontroller with a two wire SPI protocol. Some things to consider when selecting LED strips are; current consumption, number of LEDs per meter, operating voltage, number of required I/O lines, LED brightness, and price.

*Table 3.3.xvii LED Comparison [118], [119], [120]*

Model	Number of LEDs/m	Current Consumption	Operating Voltage	Required I/O Lines	Price
RGB Weatherproof Flexistrip Analog	60	60mA max	9-12VDC	3	\$25.00
RGB NeoPixel Digital	60	60mA max	5 VDC	1	\$24.95
RGB DotStar Digital	60	60mA max	5 VDC	2	\$29.95

The three compared models are all very similar. The main difference is how they are controlled. Since the analog strip would require three I/O lines and three extra transistors, it would be between the NeoPixel and the DotStar strips. Even though they require an extra I/O line and are slightly more expensive, we chose to go with the DotStar strip, mainly because it is more flexible in different applications, and doesn't require specific timing that could get in the way of our development. Both the NeoPixel and DotStar strips have a great library for Arduino to help get you started which we intend to use to our advantage. This will expedite the prototyping and testing processes with respect to the LEDs as to allow more time for project-critical systems.

### **3.3.11 Shade Material**

Naturally, a great of emphasis is placed on the technical aspects of this project. As the electrical aspects, as well as the software aspects of this project are the authors' areas of knowledge, and largely comprise the interesting parts of this project. But as the fundamental goal of this project still remains to design a blackout shade, it would be imprudent to neglect to mention the implementation of this most basic requirement for this project. As such, this section, Section 3.3.11, will be dedicated to providing the reader with some insight into the shade material that will be utilized. As has been mentioned previously, this window shade system is intended to perform as a blackout shade. That

is, it is meant to fully block incoming sunlight as to “black out” the room that the window shade has been installed in. With this requirement in mind, not all shades function in this way. Thus, some considerations must be made with regard to the selection of the shade material. In addition to the opacity of the material, available sizes, and of course, cost are all important factors in this decision. As this aspect of the project is not intended to be the emphasis by any means, a comparison of the several window shades will be neglected in this report. For the sake of brevity, only the chosen shade material will be discussed. The authors’ choice came to be the Roc-Ion® Blackout Lining Fabric-Budget®. According to the manufacturer, this shade offers “100% Blackout” which should be suitable for our application. Additionally, the fabric comes in a convenient width of 54 inches. The inexpensive price of this shade material, \$7.99 per yard is a large consideration in this choice of material. As an extra benefit, this material also allows for a certain amount of sound blocking, which while not an outlined consideration in choosing, offers a nice bonus benefit to the product as a whole. The Roc-Ion Blackout Lining Fabric-Budget should effectively block sunlight for our application. [121]

### **3.3.12 Web-Application/Bootstrap**

Bootstrap delivers prevailing front-end framework for rapid and simplistic as well as beautiful web development. Bootstrap comes preloaded with HTML and CSS design templates for common user interface components like forms, buttons, tables, navigations, dropdowns, alerts, and much more. The biggest reason for selecting bootstrap is that it lets developers create responsive flexible layouts very easily. In addition, Bootstrap makes the web application look more fluent and makes it display correctly on different devices. This is considered to be a huge help and it will solve our problem of viewing our web application on a different device. Moreover, Bootstrap offers a huge library (Bootstrap Data API), which already comes with pre-written code, ready to use. Bootstrap saves a great amount of time when using their already built in features. Bootstrap works with all of the modern browsers. [122]

From the above research, all things considered, we decided to take web application approach for our project. In addition, our web application will satisfy the definition of “mobile-friendly”. Our web application will be able to accommodate every user on any device. The Native apps approach will require creating multiple apps over different platforms, which will require a substantial amount of time and resource. Due to the lack of experience of development in native apps, our goal of accommodating every user with this product may not be a success. Due to these reasons, our goal is take a web application approach by creating one application that works on any device, whether it may be desktop, tablet or a phone.

### **3.3.13 Server Selection**

The Google Cloud Platform offers a robust, flexible, reliable, and scalable platform for hosting websites. Firebase hosting enables fast and secure static hosting for web apps. Developers can easily deploy and host the app’s static asset such as HTML, CSS,

JavaScript, etc. Firebase offers features like realtime database, test lab, cloud storage, authentication, cloud functions and remote config. Moreover, real time database is a cloud-hosted database. Data is stored as JSON and synchronized in realtime to every connected client. All clients share one real time database instance and automatically receive updates with the newest data. Real time database is NOSQL. this database is quite different from the standard relational database. For example, the real-time database API is only allowed operations that can be executed rapidly. Firebase hosting features are built around modern web developer who uses front-end JavaScript frameworks like angular. In addition, firebase hosting offers lightweight configuration options, which are used to build sophisticated web apps. One can easily route client-side URLs or set up custom headers. With the help of cloud functions, developers can easily create functions and test those functions. With the cloud function feature, many of the functions are already made and available for use in Node.js. This library is a great tool that can be used in our project. For example, with the ability of cloud function, developer can trigger a function through a HTTP request by using “functions. HTTPs”. These functions are made synchronous. We can use the following functions: GET, POST, PUT, DELETE. [123]

## **3.4 Possible Designs and Related Diagrams**

In this section, our initial designs will be explored, as well as a few detailed diagrams which lay out the foundation for our hardware and software flow.

### **3.4.1 Initial Design Attempts**

Presented in this section are several first attempts at designing the various systems our project requires. These designs are by no means the designs, or even approach that the group may take. It is the intention of this section to simply show initial attempts at designs. These systems, and designs, will be further refined and committed to in a later section. As these are first-pass design approaches, only schematics were created. It would truly be a waste of time to design a PCB layout for such preliminary designs as these designs and schematics will most certainly change as the project is continually tested and revised. Alongside the other schematics presented in this project, these were created in EAGLE. In this section the schematics will be presented and then will also be briefly discussed in why they were designed in such ways. These discussions will be kept brief due to the inevitable changes that will come to these designs. It would be unnecessary to go into great depth into a design that is guaranteed to change within the project’s timeline. There is still a lot of work to be done in this area, however these diagrams help display the connections required at a top-level view.

Here, an initial power system is presented. As can be seen in the AC-DC converter, only functional blocks are provided at this point in the design process. The power regulation is a bit more defined, as we know we will require the 12V, 5V, and 3.3V regulators. We also know that the power coming from the AC-DC converter and the batteries and the panels will need to be chosen and filtered appropriately. This is shown in *figure 3.4.i*.

## Power Regulation

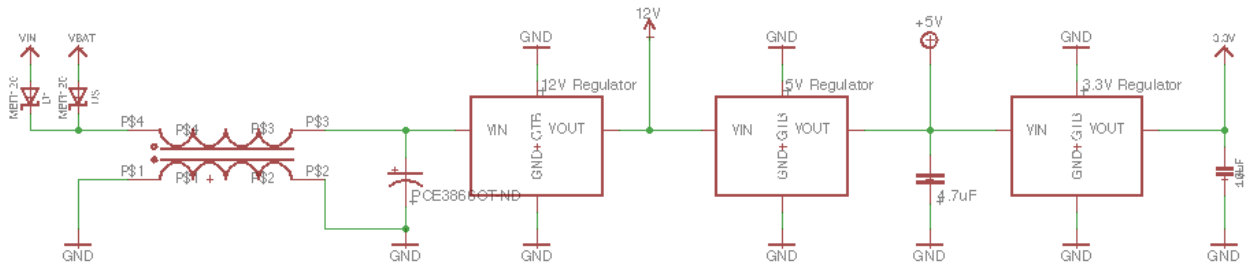

## AC-DC Converter



## Battery



*Figure 3.4.i Rough Draft Power System Schematic*

Next is the IR remote control schematic. We know that this system will be powered solely by a battery, but the configuration of the IR LED has yet to be fully implemented in this schematic. As such, it must be obvious that these schematics will inevitably change to fully encompass the entire design of the system. This is shown in *figure 3.4.ii*.

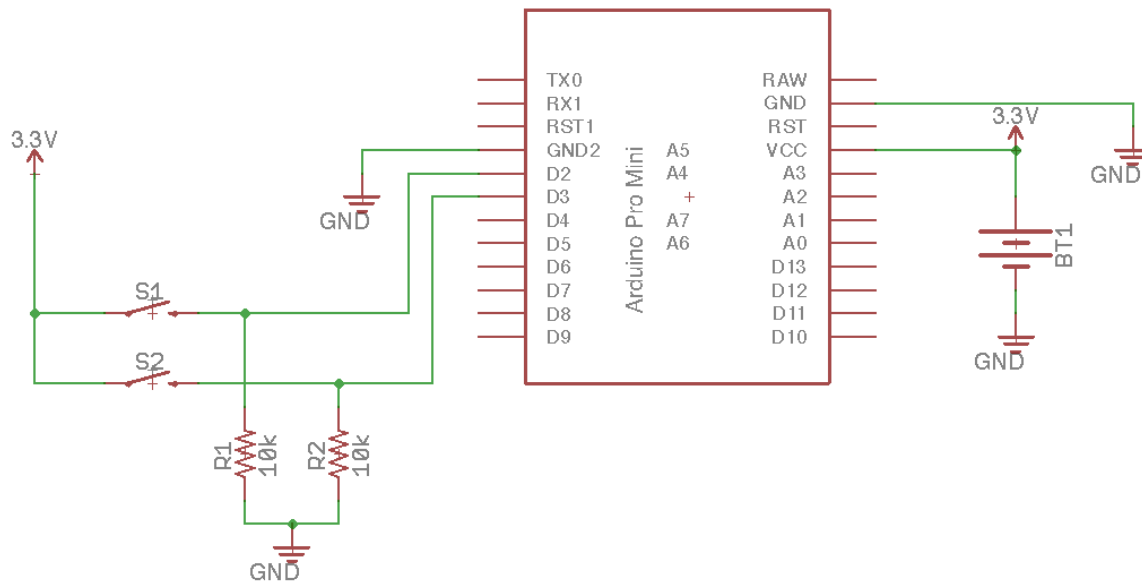

Figure 3.4.ii Rough Draft IR Remote Schematic

### 3.4.2 Pinout

Pictured below in *figure 3.4.iii* is a top-level prototype schematic created in EAGLE. EAGLE is a CAD software for electronics that allows you to create a schematic with the necessary parts for your circuit, and then from that schematic create a PCB layout. The software will tell you which pin in the device package corresponds to the specific pin in the schematic, which is very useful. EAGLE is made available by the CAD software company Autodesk Inc. A three-year student license is available for us as UCF students. For our project, we will use EAGLE for our PCB layout since it is the primary PCB design software used in the industry, and our electrical engineers already have experience using this software.

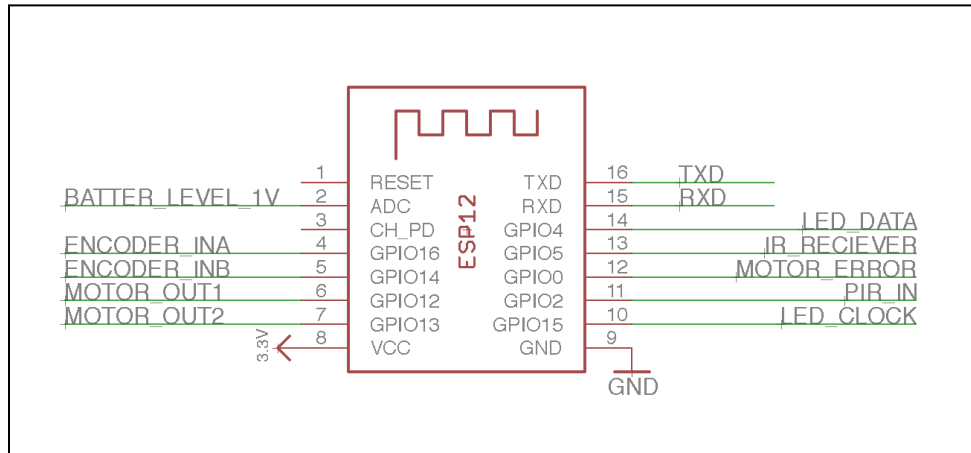

Figure 3.4.iii ESP12 Pinout

This schematic details the pinout of our chosen microcontroller, the ESP-12S, specifically for our implementation. This includes the inputs from the PIR motion sensor, the IR receiver, the battery voltage level, and the two hall effect encoders for the motor position sensing. It also includes the outputs to the motor driver, and the LED strip.

### 3.4.3 Hardware Block Diagram

A functional block diagram, *figure 3.4.iv*, is now presented in Section 3.4.3. This diagram is intended to illustrate the complete system's hardware considerations, as well as their interactions with each other within the system. As can be appreciated, the functional blocks have also been assigned to the appropriate group member. This is to ensure that there is no confusion in the delegation of tasks throughout the course of this project. *figure 3.4.iv* can be characterized as having several main subsystems: power system, remote control, sensing, motor, LED strip, and a processing stage. These subsystems are split into manageable functional blocks, such that a clear picture of the entire hardware system can be easily presented in a single diagram.

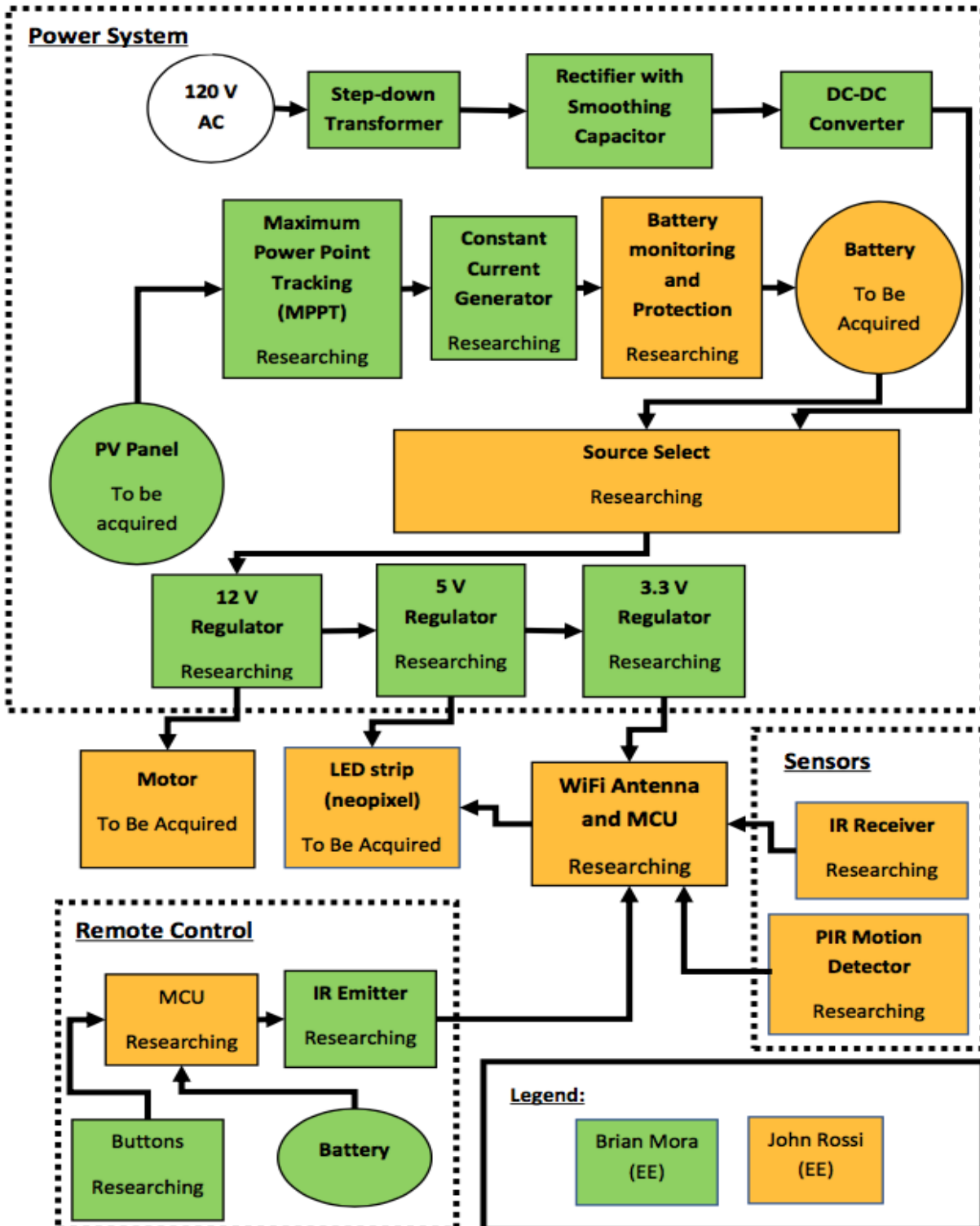
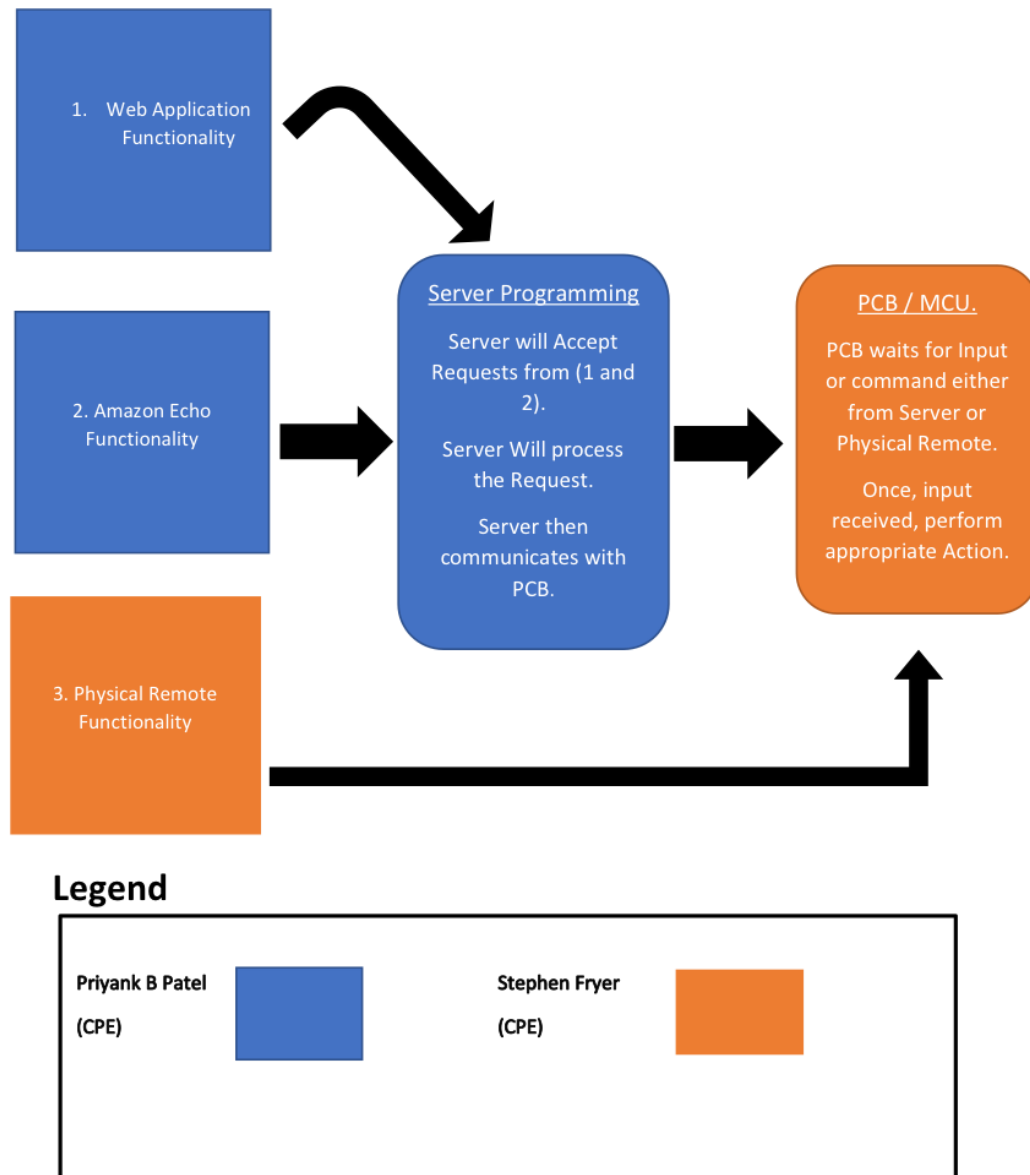

Figure 3.4.iv Hardware Block Diagram

### 3.4.4 Software Diagrams

This software block diagram outlines the main functionality of the software portion of our project, as well as a breakdown of what roles each computer engineer will play in the software development. This is a top-level diagram, and as such, each individual stage defined in this overview will be further examined in the following diagrams. This is shown in *figure 3.4.v*.



*Figure 3.4.v Software Block Diagram*

### 3.4.4.1 Web-Application Diagram

Below is the diagram that explains the workflow of the web application module. Our web application workflow explains all the functionalities of the module. Our web application will offer four distinct functions. Remote utility is one of the functions, which will let user control their shade's physical movement simply by maneuvering up/down button functionality. Another functionality provides users the ability to turn on the LED array right from our web application. In addition, users can choose their preferred shades of light. The next feature will provide real time battery levels of the battery installed in our product. Users will be able see the current battery level right from our web application. This is shown in *figure 3.4.vi*.

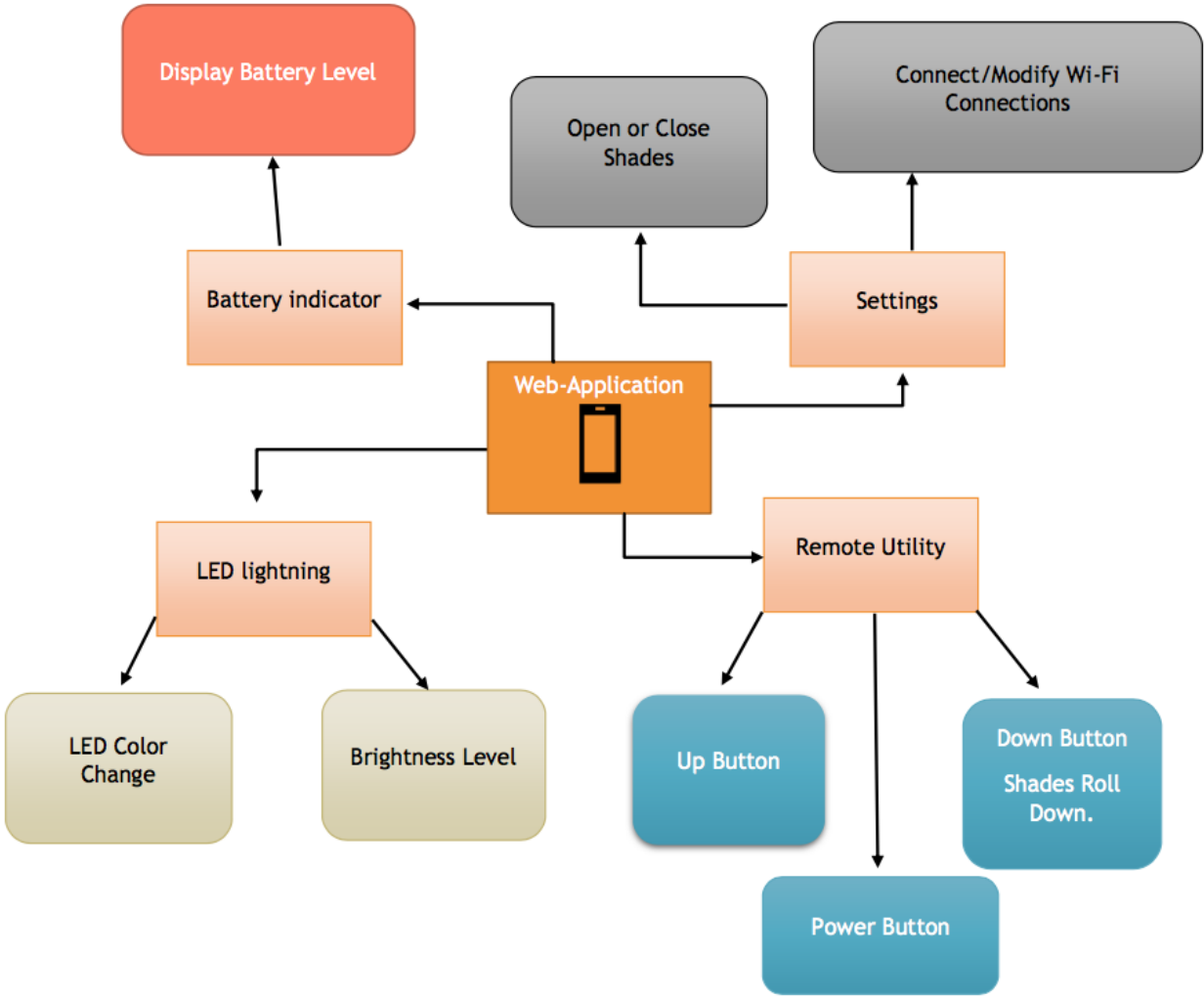
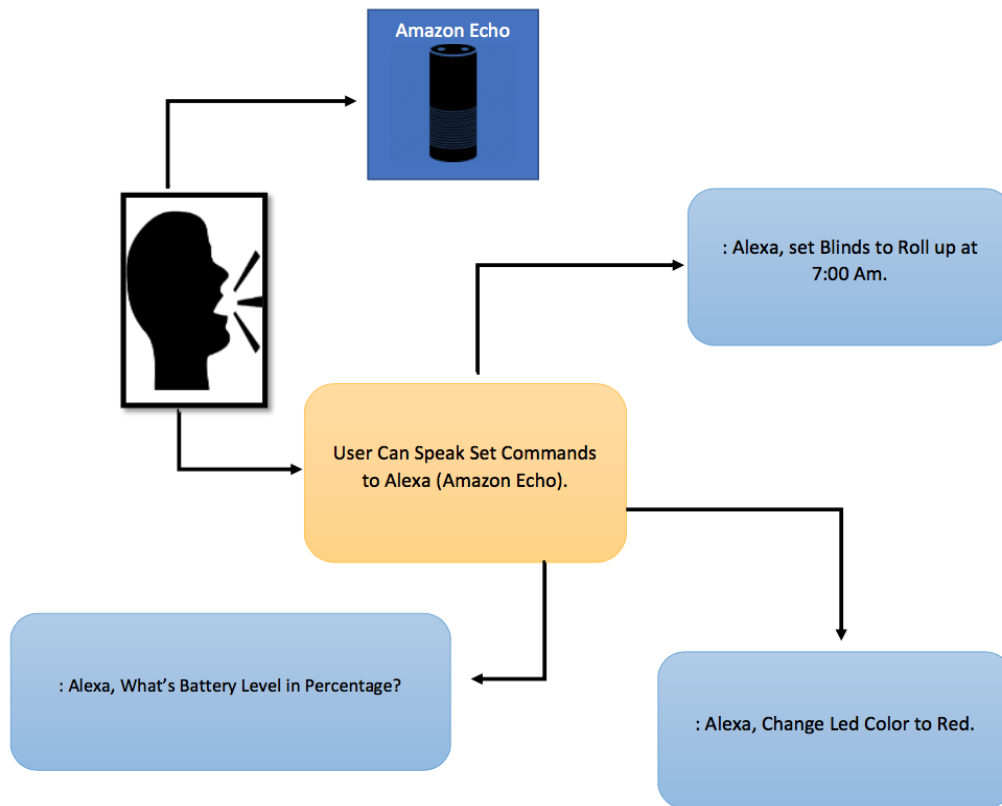

Figure 3.4.vi Web Application Functionalities

### 3.4.4.2 Amazon Echo Diagram

Users of this product will be able to control our window shades directly with an Amazon Echo, verbally, via predefined Amazon Echo commands. Our goal is to have at least three commands working such that users can control their shades. This module is a somewhat modern approach to interactions that we are taking to accommodate our users with a convenient experience. This is shown in *figure 3.4.vii*.



*Figure 3.4.vii Amazon Echo Functionalities*

### 3.4.4.3 IR Remote Diagram

The dedicated remote control offers traditional remote control interactions, allowing the users to control their window shades movement from a line-of-sight position. Our remote control will resemble traditional remotes and its features will include such things as “move windows shades up” or “move windows shades down” buttons. This is shown in *figure 3.4.viii*.

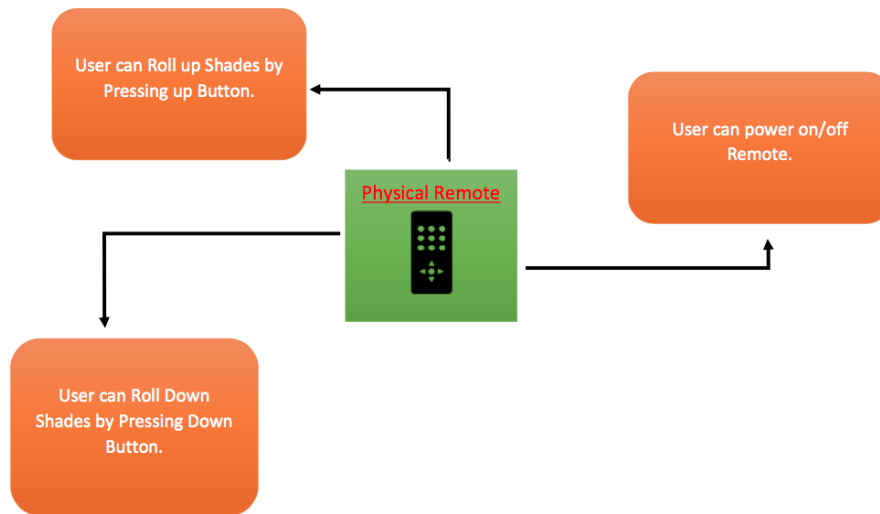

Figure 3.4.viii IR Remote Functionalities

### 3.4.5 Code Flow Chart

A code flowchart of the proposed web-interface is shown below in *figure 3.4.ix*. Code flowcharts allow for a visual understanding of the basic principles of how a code will operate.

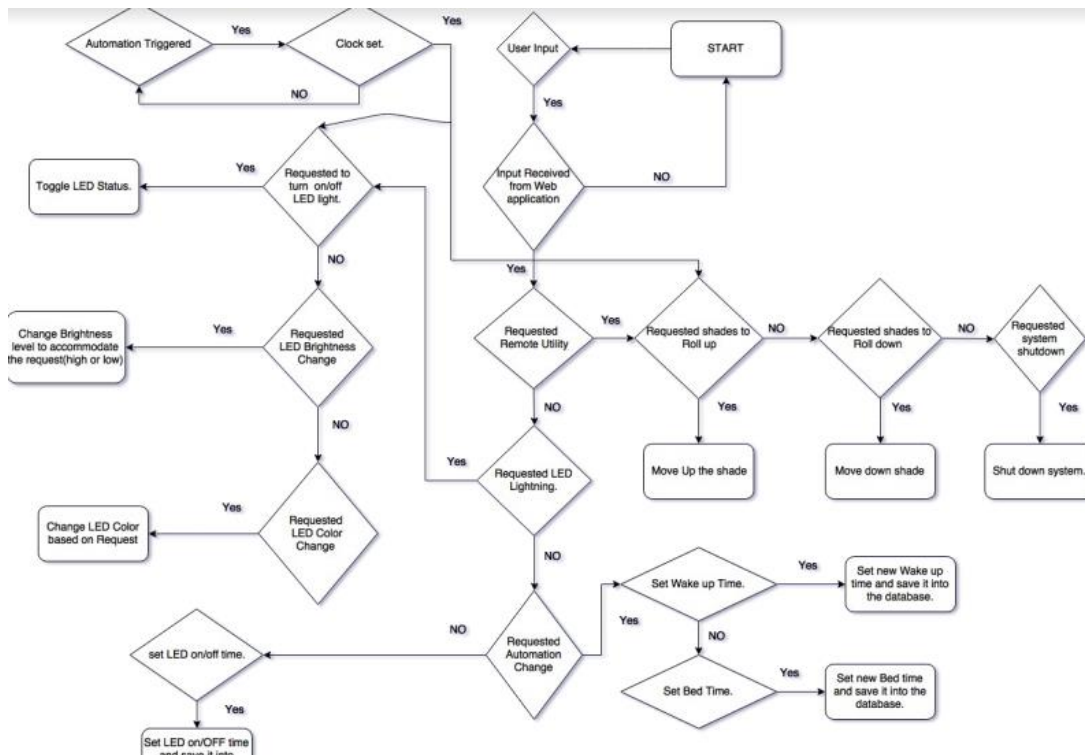

Figure 3.4.ix Code Flowchart

### **3.5 Parts Selection Summary**

Choosing appropriate parts for the project represents a significant portion of the design process. Though the task sounds simple on the outset, parts selection is in actuality a critical, time-consuming process. Throughout the parts selection process, it was clear that three main emphases were placed on the parts to be chosen: cost, size, and power. This is clearly due to nature of our project. It is our intention to make the smart home window shades cost-effective, after all, it is meant to culminate to a consumer-product. Making the system small, and portable, will also help with the ease of install and flexibility to fit in a wider range of windows, and thus in more homes. Since the system is meant to be powered wirelessly through solar power, the less power the system draws, the more margin the solar system has. These were the main guiding factors in parts selection. It should also be noted that as this project is in the prototyping stage, parts were primarily also chosen for the prototyping stage. This is not to say that the final design's parts will have changed completely, but it may be the case that a part that was most suitable for prototyping is no longer the most suitable for the final product. Additionally, out of the utmost prudence when ordering parts, when possible, duplicate parts were ordered. This is to provide ourselves with some overhead if mistakes should occur in the prototyping and testing stages.

## **4.0 Design Constraints and Related Standards**

Standards are an integral part of modern technology. They allow different developers and products to interact with each other in predictable ways. Standards also allow technologies to be more easily integrated into new products. Consistency is an important aspect to allow innovation to occur. An important standards organization relevant to this project is the Institute of Electrical and Electronics Engineers Standards Association (IEEE-SA). This association facilitates standards development in a wide range of technologies. Our project involves several technologies that have standards developed by IEEE-SA. IEEE-SA is by no means the only standards association, but in the context of this project's technologies, they provide the most relevant standards. These relevant standards will be discussed in Section 4.1. [124]

### **4.1 Related Standards**

1. 802.11 – IEEE Wireless Local Area Networks: These standard outlines specifications for wireless local area network communications in most commonly 2.4, 3.6, and 5 GHz frequency bands. These standards outline media access methods, modulation techniques to be used, and security schemes such as Wi-Fi Protected Access and AES Pre-Shared Key. Wireless networking products under the Wi-Fi brand must adhere to these standards. [125]
2. 1625-2008, 1725-2006 – IEEE Standard for Rechargeable batteries for multi-cell Mobile Computing Devices: These standards outline best design practices to ensure quality and reliability of Lithium-ion batteries in mobile computing devices.

These standards also address battery pack construction, discharge controls, and battery status. Additionally, this standard also addresses end-user notifications. [126]

3. 1526-2003 – IEEE Recommended Practice for Testing the Performance of Stand-Alone Photovoltaic Systems: This presents best practice tests for measuring photovoltaic system performance. It should be noted that these recommendations address mainly photovoltaic systems design and do not intend to outline best practices for safety.
4. 1754-1994 – IEEE Standard for a 32-bit Microprocessor Architecture: This standard defines an instruction set, data types, registers, and instruction op-codes. It is also available to users. Scalable Processor Architecture instruction set is included in the outlined instruction sets. [127]

It should also be noted that the standards outlined in this section are not exhaustive to the technologies involved in this project, but the standards outlined are, in the estimations of the authors, illustrative of the breadth of standards that are available in even such a limited scope as this project. There truly seems to be a standard for everything, and as such not all standards can be discussed in this section for the sake of brevity. Another point of note is that only the scopes, and intentions, of the standards in this section have been set forth. The standards themselves are not freely accessible, and as it is not the intention of this project to fundamentally change any of these standards, it has been deemed reasonable that only a brief overview of the standards be necessary. It is not the intention of this section to provide any meaningful specifics into the practice of the standards presented. It is the intention of this section to allow the reader to glean the types of technologies that have standards.

## **4.2 Design Impact of Standards**

As previously discussed, standards are a friend to innovation. This is true, yet they still pose certain design impacts on this project. To be used effectively, obviously standards must be followed. If a standard is not followed properly then the results can be unexpected and incompatible with other systems that expect inputs according to a standard. Section 4.1 prevented various relevant standards to the technologies utilized in this project. To make an effective use of these standards, they must be followed. For example, the WiFi module we have chosen, was in part chosen, because it adheres to the WiFi standard set forth in Section 4.1. Adhering to this WiFi standard ensures that our system will work with all other products that are also adhering to the WiFi standard. It also ensures that our software interacts appropriately with the hardware, as our software will expect the hardware to adhere to the WiFi standard. The example of the incorporating the WiFi standard into our design is representative of the impact that standards have on the design process. It is also in part, thanks to standards, that it is even possible to use a WiFi module at all. If there were no standard, then we might have instead had to build an entire module from scratch. The other standards, outlined in Section 4.1, had similar effects on the design process in this project.

## **4.3 Realistic Design Constraints**

Design constraints in a project design are imminent in the development phase. According to Ford and Coulston, all defined engineering requirements potentially present a few constraints on a design. However, in designs and ultimately finished products, constraints are, in other words, requirements, design decisions forced by a factor that affects or limits the design. [1] Constraints indicate how the system will be executed. Design constraints can vary in different project aspects. Projects constraints vary in various aspects, for example, functional constraints, efficiency, reliability, fit for purpose, cost and time, maintainability, and environmental friendly. Based on Michael Keeling, constraints identifying comes from a variety of sources. Although, it's very difficult to anticipate constraints before development begins, it's very crucial to understand the obvious constraints of the project before jumping on a project. He also believes that many times, stakeholders will bring concern that could end up in constraints, halfway through the development. Therefore, it is necessary to understand all the engineering requirements and its potential drawbacks. Moreover, many times business decision plays key role in development of the design. Many times, business designs are somewhat final, and therein, cannot be changed. So, design team must work around that constraint. Below are few project constraints that we will likely face in our project indefinitely.

### **4.3.1 Functionality Constraint**

As with all of the constraints discussed in these sections, in a sense they are all interrelated. That is to say, the constraints affect other constraints. The functionality constraints of the system are no different. For example, if there were budgetary constraints a variety of additional sensors would be added to the system, such as an ambient light sensor, etc. But because of the economic constraints imposed on the project, certain functionalities are necessarily deemed either necessary or not necessary. In other words, economic constraints inherently require an analysis of the necessity of system functions. As discussed in a previous section, certain engineering requirements have been set forth for this project. Certain functionality constraints are embedded in these developed engineering requirements. The situation certainly arises where a compromise must be made between what a system is actually capable of, and what a scaled-down capability a system should be required to do. Additionally, standards impose functionality constraints. These standards will dictate the functions, and implementations, of the systems relevant to the standard. There is certainly always a struggle between the bottom-line of functions a system must be able to perform to be considered a successful project, and what the designers know, and wish, the system is capable of bar other constraints. Functionality constraints mark a very clear intersection of market and engineering requirements meeting.

Functionality constraint refers any restraint that project may experience during its hours of operation. One of main concern in that aspect would be losing Wifi. Since our product is reliant on wi-fi as far as communication, losing Wifi would absolutely limit our product as to number of operations it can do. For example, if users lost connectivity from our product with Wifi, product would stop communicating with our servers. Therefore, our web

application then would stop responding user's commands. Amazon echo absolutely need Wifi for operation. If we lose Wifi, amazon echo's predefined commands with not communicate with our device. Making sure our product is connected to Wifi always is necessary for smooth operations of our product.

Our product has multiple ways of receiving power to make sure our product is operational at all time. Our main source of power during daytime would be solar energy. Our product would constantly need to receive solar energy and converting it to the electrical energy. If for some reason, it stops receiving solar panels, and it switches to our battery for source of power. If in case, battery is drained, then it switches to third option for source of operation. This would be home's typical electrical power source. Our product is hooked to home's power grid for source of power in case malfunction in solar panels and battery not holding charge. Our product once again, has multiple ways of receiving power in case initial options fails. Another thing to point out would be, if our solar option as way of sourcing our product fails, then we wouldn't be able to guarantee cheapest way to operate windows shades. Our main goal in project is to make sure that our users can use this product in the cheapest way. We exhaust all the possible ways to accommodate the user's need, and making sure that they window shades are operational all time.

### **4.3.2 Economic Constraints**

Projects are started after project managers and a few key members of the company assess the project in a realistic manner. They discuss the cost of the development as well as time constraint. After that, the project manager communicates with the development team for building the new project with certain given time constraints, as well as with a budget. Every developer must learn to deal with money constraints. Our project, as we assess before accepting the project, would ideally cost as mentioned to be \$400. We, as developers need to complete this project under this value listed. Many times, it is hard to complete a given project under given budget due to unexpected expense or unknown factors previously not considered in related project cost. In our project, we always encounter a tradeoff with high cost of a parts with better functionality versus lower cost of a product with lesser functionalities. Many times, parts that are less expensive may not be in stock. This creates stressful situations where developers either must buy higher priced parts, which may not be viable solution due to budget, or they may buy lesser price parts that may not function well, which violates the reliability constraint. Many times, to avoid these situations, project managers and R&D teams usually discuss the cost of development, keeping in mind all of the necessary parts required and related costs of those parts, before setting a budget. We absolutely took this approach. We considered all the necessary parts and related costs, and discussed that with our sponsors, and generated a reasonable budget.

### **4.3.3 Time Constraints**

Project completion in timely manners can be horrifying, especially when the timing is superimposed by another entity. For instance, once, development begins, many times

due dates are not changeable. In other words, once we promised a client the delivery of the product on a certain date, companies cannot risk of disappointing the customer by prolonging project release. Due to this reason, product must be completed on a given date. Our project due date is already predetermined by our university on behalf of our sponsor. To complete our project, we are given two semesters for completion of the project. First semester entails arranging a document explaining the research on the project, parts, explaining ways to complete this project, and lastly creating a budget as well as arranging a timeline for completion of project. the timeline of project explains which parts will be completed by which date as mentioned in our milestone discussion of this document. this semester will also use to buy all parts, and creating schematic designs. Next semester, we began to really jump in and design, build and test and complete this product. time constraint plays huge role because this project involves working with different members. Each member of the may has other agendas interfering this project. for example, all the members may be otherwise engaged in school-related tasks, or job-related tasks, or even leisure activities, and these kinds of situations forbidden us from working on our project. thus, time constraint plays huge role because each member must understand these constraints and develop a time management strategy that will help to complete this project.

#### **4.3.4 Environmental/Manufacturability Constraints**

Often times, the environment places key constraints in a project's success. Environment factors can include where the product will be operating. From our web application perspective, although modern operating systems as well as web browsers will be compatible for full functionality of our web application. However, different environment such as different operating systems and web browsers will slightly affect our web application's performance and viewability. Web application viewed from google chrome will be preferred over other browsers. Web application viewed on internet explorer potentially may not display all the necessary components of our web application. Similarly, our web application may not work in many of the older operating systems such as windows 98, or windows XP. In other words, minimum hardware/software that are required to run web browsers such google chrome are required for functionality of our web application. Another important environment constraints we are likely to face physical home's windows sizes. Typically, not all homes are built the same way, and therefore, may not have the same window dimensions. So, our built product only would work on dimensions that have been listed in this document. Our goal as well as our sponsors is to make this product more generic, so, it's able to work on home windows of any dimension. A good project strategy is to build a single product that is considered a base that will be started on. After that, the next goal would be to use the base project as reference to make our product more generic to fit any window. Since, this project will be used as the base of this product, our final product will only work on windows whose dimensions are listed in this document. This is a major environmental constraint that we are facing, for now.

## 4.4 Arduino Development Guidelines

The guidelines presented will be utilized in our project since the Arduino IDE is where all the code for the embedded systems design will be implemented. There is a list of coding conventions that are strongly recommended to be followed when developing for Arduino-based microcontrollers that is indicated in the Arduino style guide. Even though these guidelines are not technically standards, our group will treat them as such so that the code written is simple to understand and easily read.

### 4.4.1 Naming Conventions

In order to preserve the code being easy to understand, naming conventions will be descriptive and consistent. The Arduino style guide says to avoid single letter variable names since those are not descriptive. `#defines` won't be used for quantities that won't change, constant integers will be used instead. This makes the code look less messy. [128]

- The name of any constants used will be written in all capital letters.
- If a space would be needed in the name of any constant created, an underscore will be used in its stead.
- Any functions created will follow the practice of camel casing where the first word of the function uses a lowercase letter and each following word will begin with an uppercase letter. Spaces and underscores will not be used in-between each consecutive word in the function name.
- Function names will not be chosen at random. They will be related to their purpose and distinct.
- File names will also utilize the camel case practice. However, the first letter of the file names will be capitalized.
- Like function names, variable names will also be descriptive and unique that clearly explains the purpose of the variable.
- Variable names will be in all lowercase letters.
- Variable names will also use underscores to replace spaces.

### 4.4.2 Blank Line Standards

Having appropriate spacing with the use of blank lines allows for easy readability. This allows the code to be quickly scanned when searching for anything in the code. [128]

- Two blank lines will be put in-between the end and start of two functions.
- If two sections of code are vastly different, three blank lines will be used to allow proper spacing.
- Any return statements will have a blank line after the previous line of code. The ending bracket for any function will always be on the line below the return statement. We believe this clearly indicates the end of a function.

- One blank line will also be used to separate code when deemed to improve readability. An example of this would be immediately after any variables are declared or after a conditional statement has finished.
- In any other instance, a line break will not be utilized unless it is related to one of the categories presented above.

### 4.4.3 Function Formatting Standards

For any function, including the main two functions the Arduino boards require, `setup()` and `loop()`, it will follow these rules [128]:

- All functions will have a short and specific description above the name as a header. This may be done in one sentences or possibly a few depending on how much the function effects the program. These will be written between the forward slash plus followed by an asterisk and an asterisk followed by a forward slash.
- Immediately after the function name, the function parameters or function arguments will be given.
- After this, a space will be used before the opening curly bracket on the same line, indicating the start of the function.
- The rest of the functions code will be put on the next lines below the function name.
- An indent will be used to indicate the code of the function.
- Tabs will not be used since they can cause portability issues.
- Whenever a tab would be used for indentation, five spaces will be used instead.
- The closing curly bracket will always be on the line below the last statement of code using the indentation of the function name.

### 4.4.4 Comment Standards

The Arduino style guide has clear preferences on how the code should be commented. The following will be implemented in our code [128]:

- In-line comments will use two forward slashes that follow the line of code after a space. These will be used for very short comments when deemed necessary in order to avoid overcrowding the code with comments.
- Every variable and constant declaration will be commented with a short description of what the variable or constant does. This allows readers to not have to search for a variable within the code to find out how it is used.
- Before every code block, a comment will describe what the code block does.
- Every for loop will be commented to avoid the reader having to iterate through the loop to find out what the loop does.

## 4.4.5 Conditional Statement Standards

In order to preserve consistency throughout the program, all conditional statements will follow the same rules listed below [128]:

- The type of conditional statement will be written and immediately followed by the opening parentheses. A space will not be used as other statements will not be using this way of formatting.
- Similarly to functions, a space will be put in-between the closing parentheses and the opening curly bracket. This will be done on the same line.
- The following code of a conditional statement will use an indentation.
- At the end of the entire conditional statement, a closing curly bracket will be put on a new line below the last statement of code. This will have the same indentation as the start of the conditional statement where the type is indicated.

## 4.4.6 Miscellaneous Standards

While these rules don't fit into any of the previously stated categories, they are still important to follow and key to keeping out code look professional [128]:

- Each line of code will not contain more than 100 characters excluding any type of comment.
- Pointers will be avoided unless absolutely required.
- #defines will be avoided as well.
- The wiring/Processing-style variable types will be used (such as boolean, char, int, long, etc.) instead of cases like uint8\_t, etc.
- The code will be thoroughly explained at the start.
- Acronyms and abbreviations will not be used unless they are spelled out first.

# 5.0 Project Design

In this section of our paper, our initial designs and ideas will be explored and presented. Using the main components and software listed above, we will begin to form a design including main PCBs, a web application, a cloud server, and amazon echo commands/skills. As this project is still a work in progress, the final design is susceptible to a vast amount of change as testing and prototyping progresses.

## 5.1 Hardware Design

In this section, a first revision of each board will be present, including all the necessary components and connections. Since our project is space limited, and certain parts need to be placed in specific places, we have split our design into four different PCBs. A Power Board, a Control Board, a PIR board, and a IR Remote Board. A walkthrough of each board and its functions will be explored below.

### 5.1.1 Power System

The main power board will hold the AC-DC converter, with a flyback topology. The main controller being the UCC28630. The majority of the components on this board are there for the UCC28630, but there is also a bridge rectifier for rectification, and several large inductor, L1, and capacitors, C1, C2, and C3 for filtering. As can be appreciated from this schematic, there is no secondary side sensing necessary due to the bias winding of the transformer. The diodes, D1 and D2, on the AC side of the bridge rectifier to the HV pin of the UCC28630 allows for a quick start-up mode. This is shown in Figure 5.1.i.

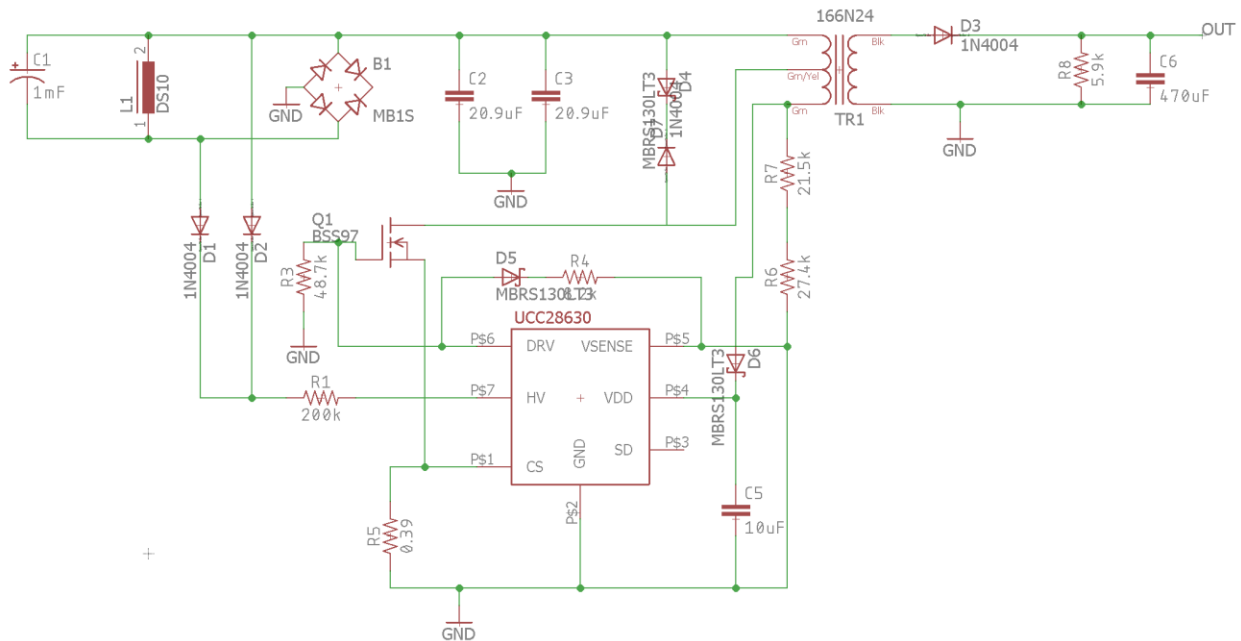

Figure 5.1.i Initial Power System Schematic

## 5.1.2 Main Control System

The main control board will hold the main microcontroller unit, which is the Wi-Fi SoC ESP-12s. Surrounding this MCU will be all of the peripherals that our product will use. This includes the motor, LEDs, IR Receiver, and PIR motion sensor. The MCU will also take in a voltage reading from the battery pack. Since the ESP-12s has a 1V maximum ADC channel, the battery voltage will have to be divided using a simple voltage divider circuit. Pictured below in *figure 5.1.ii* is the first revision schematic for this board.

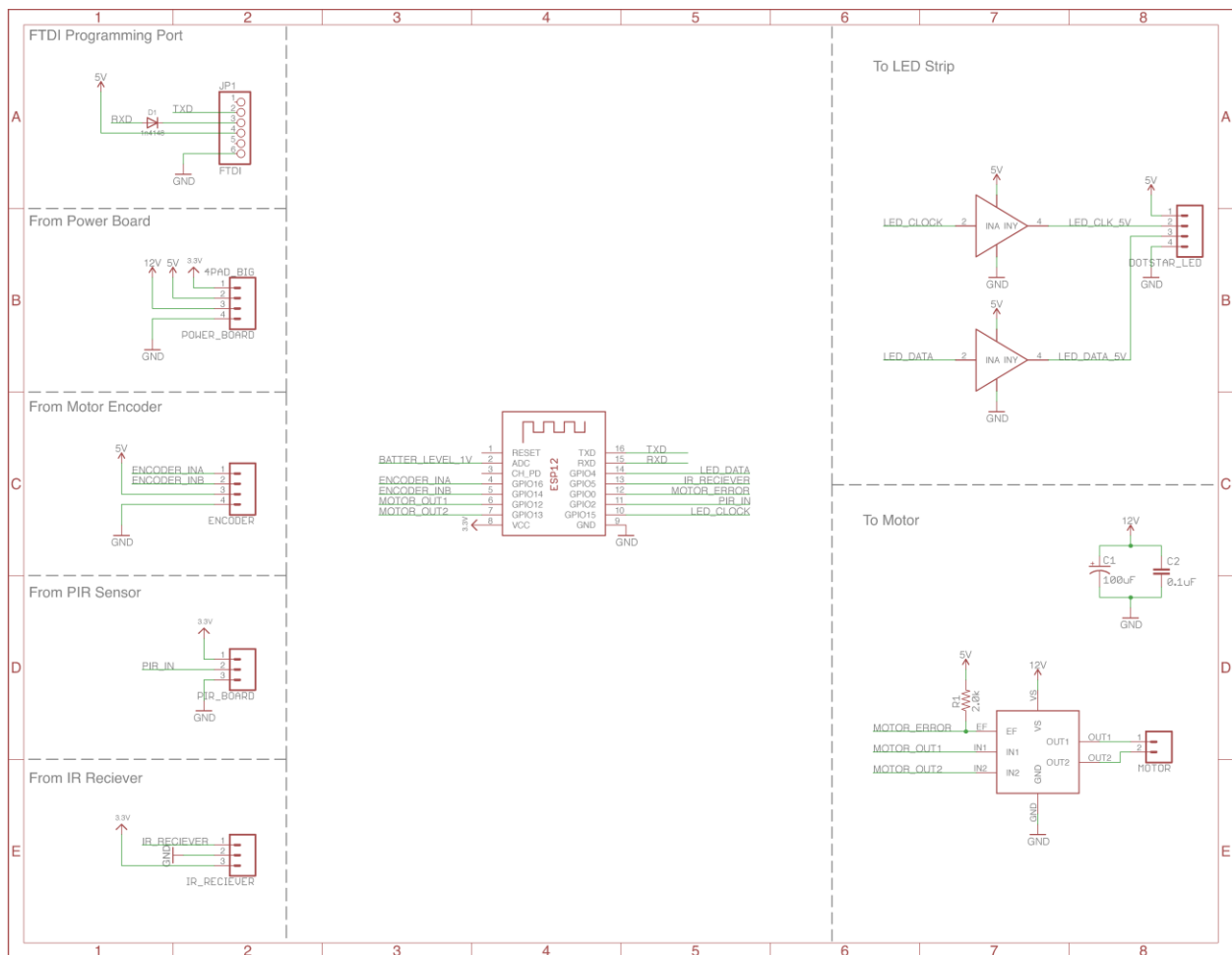

Figure 5.1.ii Initial Main Control System Schematic

As commented in the schematic, the inputs to the microcontroller are listed on the left, and the outputs from the microcontroller are listed on the right. In the top left corner, sections A1 and A2, is the programming port. The breakout board used for developing and prototyping with the microcontroller uses a simple FTDI header programming cable which we will incorporate in our design. FTDI stands for Future Technology Devices International, and is a company that offers many different chips for USB to serial

communication. The programming cable that breaks out into these headers has its own USB to serial circuit built in. This allows us to simply program the microcontroller from the software IDE on our computer.

In section B on the left are the power inputs, which come wired from the power board. It is important that we have 12V, 5V, 3.3V, and ground to power each device that requires voltage levels. The power comes from the AC-DC converter or the battery pack, and the linear regulators that are housed in the power board. In section C on the left side of the schematic, we have the input from the motors built in encoders. These allow us to track the rotation of the motor for position sensing. The encoders themselves require 5V from the system, separate from the motor power. Then in section D, we have the input from the PIR motion sensor. This goes to the motion sensor board that will be housed in the front of the shades housing, which allows for the best view of the room. Lastly, in section E, we have the input from the IR receiver which takes commands from the IR remote in the form of a specific code. This can then tell the microcontroller to roll the shades up or down.

On the right side of the schematic, we have the two outputs. On the top right, is the two-wire SPI output to the LEDs. The LEDs require a clock signal and a data signal. Since the LEDs require 5V logic, and our microcontroller only outputs 3.3V from its I/O lines, a logic level shifter is required on each line. Pictured in the schematic is Texas Instruments SN74LV1T34, a single power supply buffer gate CMOS logic level shifter. This allows the output to be shifted from 3.3V up to 5V. On the bottom right is the TLE 5206-2 motor driver, and the output to the motor. The H-bridge requires two inputs, to drive the motor in two different directions. One stays constant while the other gets applied a PWM signal to control the motor speed. The motor driver also has an error flag output fed back to the microcontroller which goes low when an error event is triggered. This can mean a short circuit between OUT1, OUT2, Vs or GND, an over-temperature shutoff, or an over/under voltage shutoff.

Pictured below in *figure 5.1.iii* is the board layout for the schematic above.

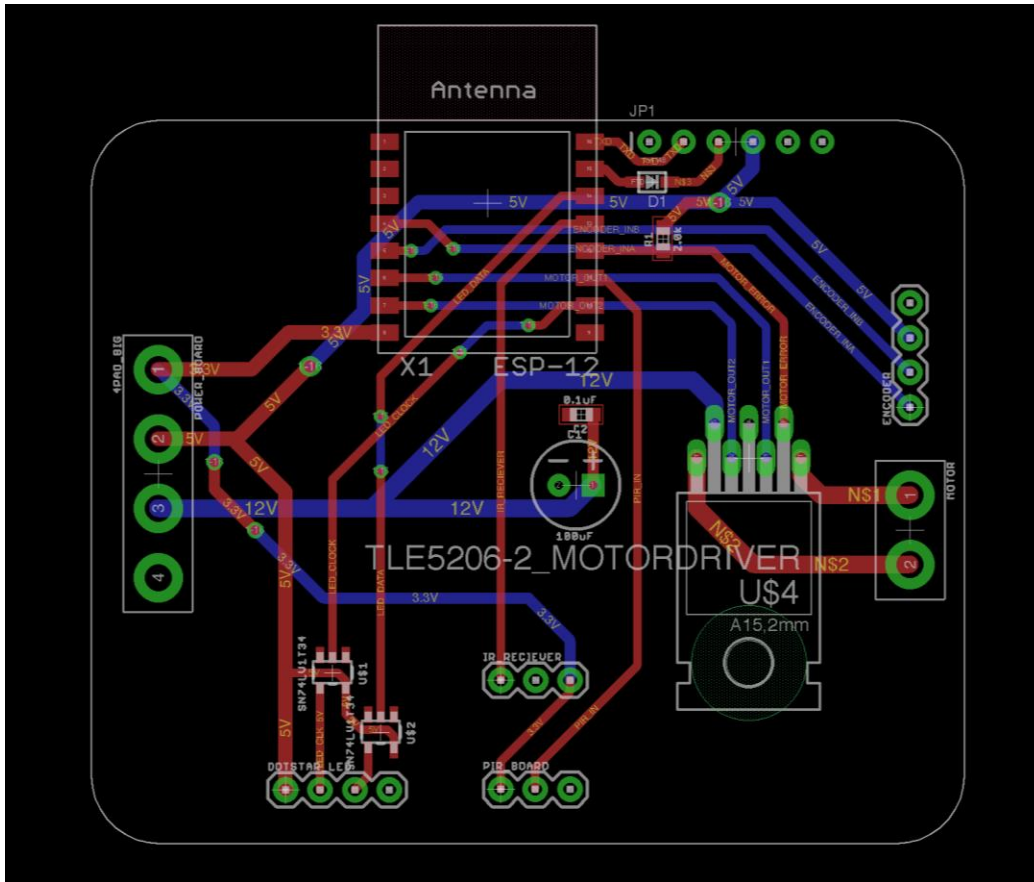

Figure 5.1.iii Initial Main Control System Board Layout

### 5.1.3 PIR Board

The PIR board will house the passive infrared motion sensor and be housed at the front of the shades housing. This will allow for our sponsors system to have motion detection in any room that the shades are installed. This can be beneficial for things such as turning on the lights based on motion, in a room that is not used very often. Eventually our sponsor will also tie this function into their security monitoring system, and allow the ability to alert the homeowner if there is activity in the house when they are not present. Pictured below in *figure 5.1.iv*, is the PIR board schematic.

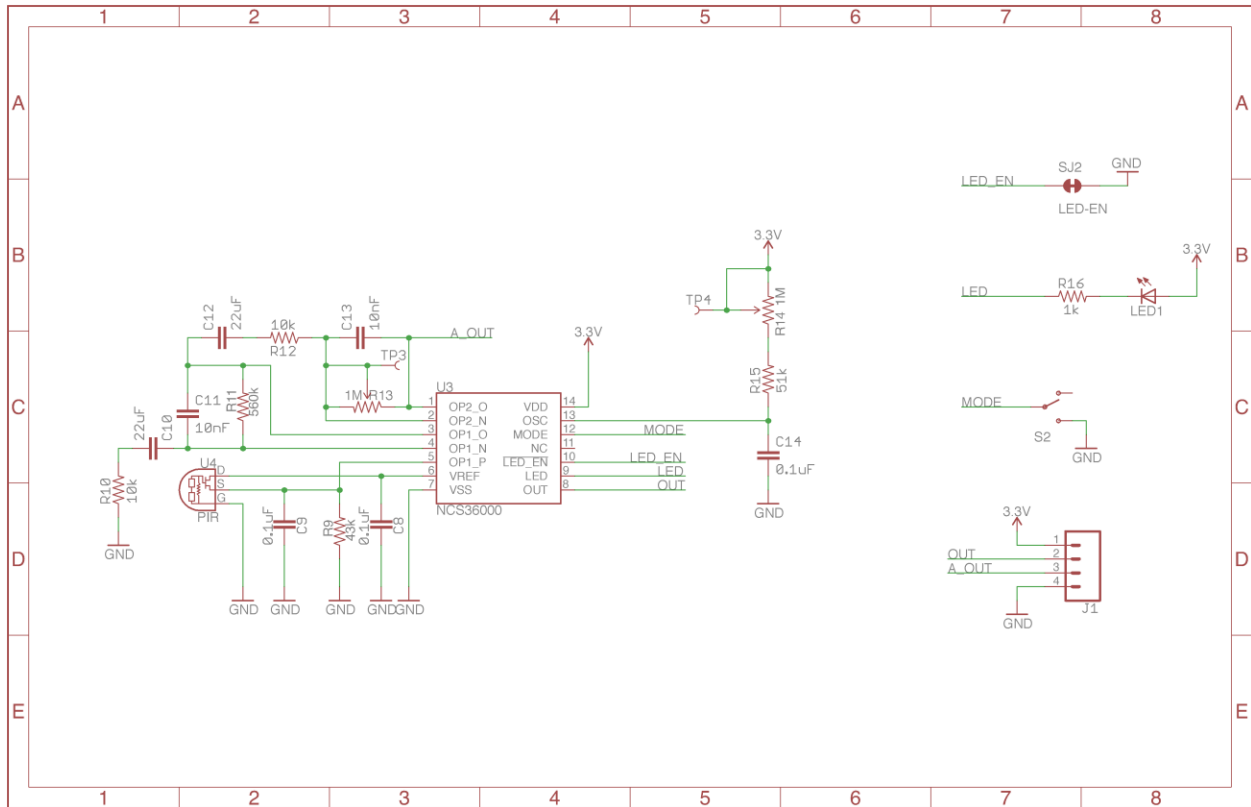

Figure 5.1.iv Initial PIR Schematic

The main chip in this schematic is the ON Semiconductor NCS36000 passive infrared detector controller. This integrated circuit has two low-noise amplifiers and a LDO regulator to drive the passive infrared sensor. The digital control circuit then processes the data from the passive infrared sensor through a window comparator, and provide the output to the LED and the output pin. This chip accepts input voltage from 3 to 5.75 volts, so since our microcontroller uses 3.3 volt logic, we will power the chip with 3.3 volts. Towards the bottom left of the schematic, you can see the PIR sensor which has three terminals, gate, drain, and source similar to a MOS transistor. The external circuitry contains an RC circuit to set the internal clock frequency of the oscillator. The two internal amplifiers are configured as a band pass, and the external components are used to set the cutoff frequencies and passband gain.

The mode switch on the right-hand side of the schematic is used to switch between single-pulse and dual-pulse detection modes. Single-pulse mode will trigger the OUT pin if either comparator toggles for an appropriate length of time. While dual-pulse mode requires two pulses (one from each comparator) to occur within the timeout period of 5 seconds or 312 clock cycles. Dual-pulse mode is usually slightly less sensitive and more accurate than single-pulse mode. The jumper at the top right of the schematic is used to enable the LED. If the jumper is populated, which it is defaulted to, the LED pin will trigger when the output pin goes high. If the jumper trace is cut, the LED will not trigger when the output

pin goes high. This is useful because while the LED is useful for debugging purposes, it may not be necessary in our actual implementation. Also a part of the external components are two potentiometers, used to control the sensitivity of the sensor, and the length of time the output remains high when activity is sensed. The sensitivity potentiometer can vary the distance that the passive infrared sensor can see, however this will decrease the sensitivity of the sensor. The potentiometer attached to the OSC pin, is the pin that changes the length of the output state. This can be toggled from as low as 400 milliseconds, all the way to 7.5 seconds. Lastly, the analog pin, labeled A\_OUT, is the output of the sensor before it is sent to the window comparator, this allows us to see the profile of the motion, in order to get a better idea of what is being detected.

Below in *figure 5.1.v*, is the board layout for the PIR board, done in EAGLE. The board size is designed around our chosen Fresnel lens. The outline in the middle of the board is the actual lens size, and the board extends out further to allow room for the mounting holes to be screwed to standoffs that will be in the housing.

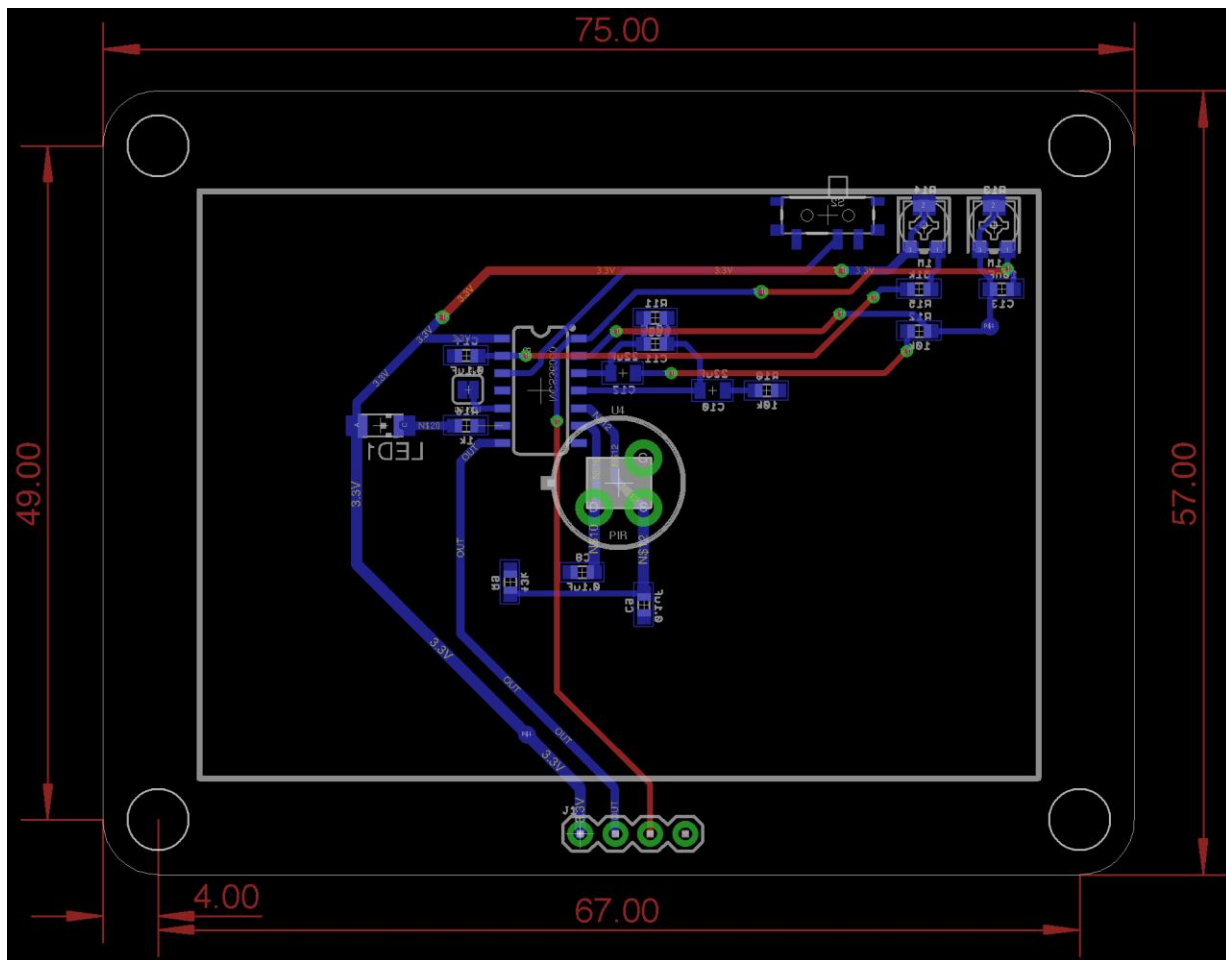

*Figure 5.1.v Initial PIR Board Layout*

## 5.1.4 IR Remote Board

The IR remote will consist of very few components. The main reason behind having the IR remote is to allow the user to have control over the shades main functionality even if the Wi-Fi network is not available. The IR remote will allow the user to be able to draw the shades up and down using a simple microcontroller and a few buttons. Displayed below in *figure 5.1.vi* is the schematic for the IR remote.

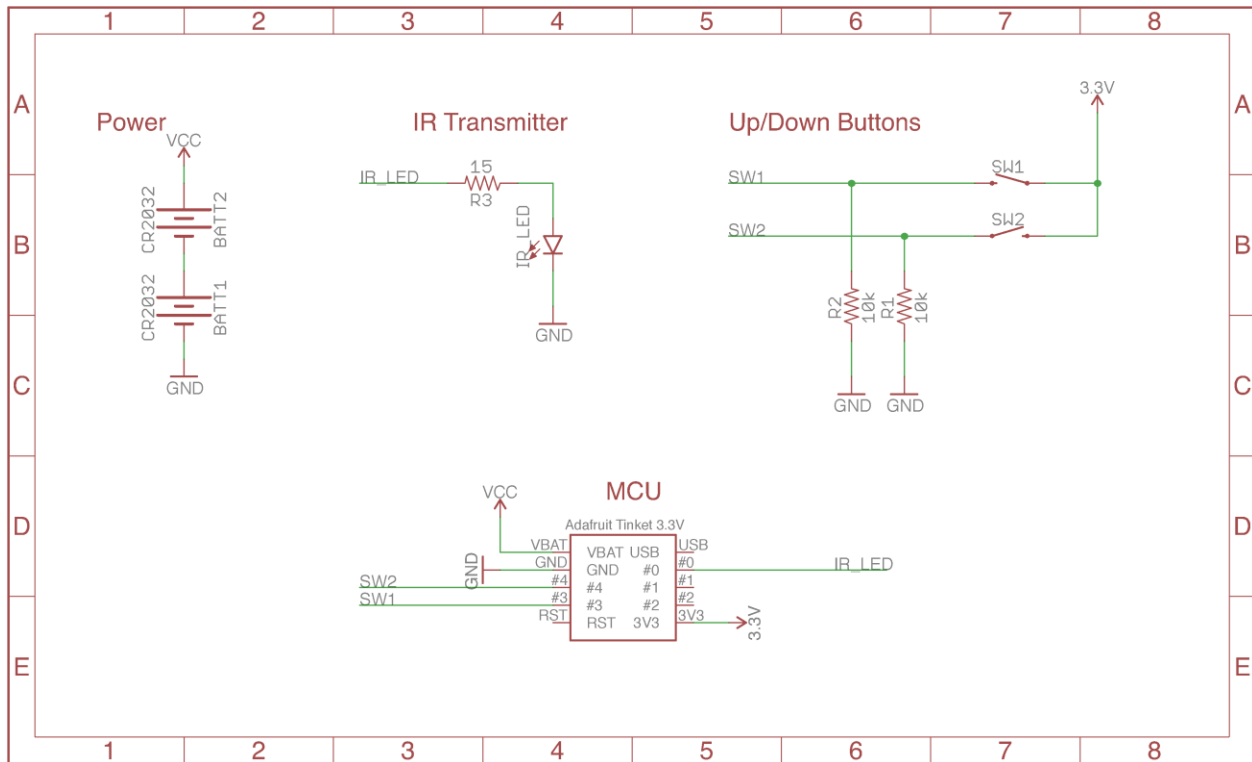

*Figure 5.1.vi Initial IR Remote Schematic*

The main control unit for this remote is the Adafruit Trinket. This tiny micro controller unit has a built in voltage regulator that accepts up to 16 volts. It also has a built in micro-USB port for programming, and 5 I/O lines. Since our remote only requires 3 I/O lines and this microcontroller unit is very low power and very small, the trinket should meet our requirements. The board will be powered by two CR2032 batteries in parallel to achieve 6 volts, which will be regulated down to 3.3 volts on the trinket. This 3.3 volts will then be used to power the IR LED and switches. The IR LED, displayed in the top middle section of the schematic, will be driven with a PWM output, to send IR pulse codes to the IR receiver in the shades housing. The buttons on the top right of the schematic are pulled low with the 10k pull-down resistor, until the button is pressed. When the button is pressed, the microcontroller will receive a high signal, and then proceed to send the pulse code to the IR LED.

Below in *figure 5.1.vii*, is the board layout for the IR remote.

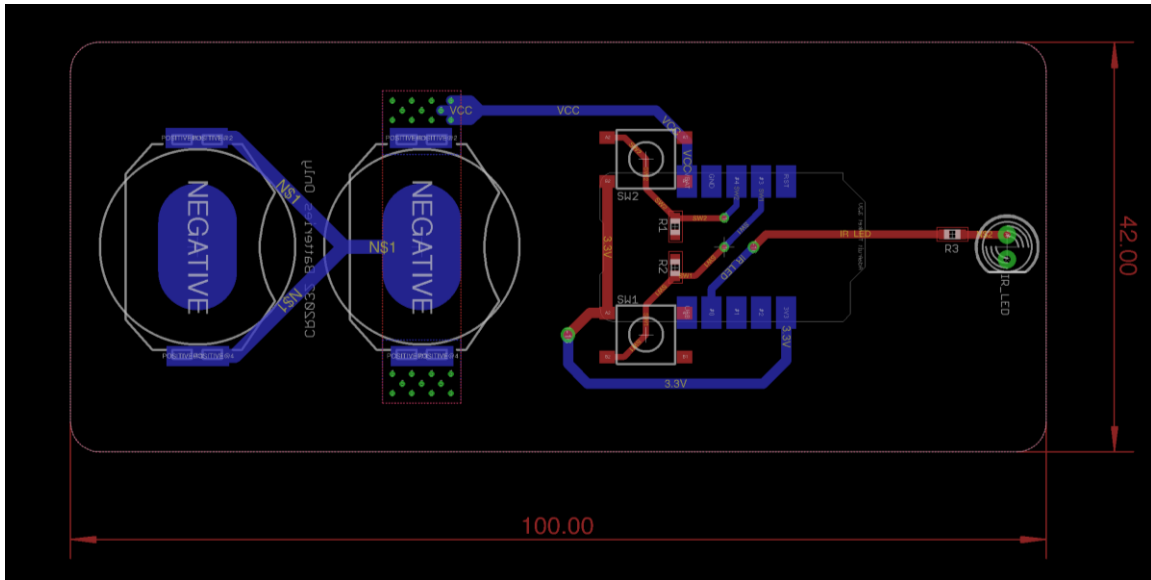

Figure 5.1.vii Initial IR Remote Control Board Layout

The trinket will be placed on the back of the board using surface mount pads to conserve space. The batteries will also be mounted on the back so they can be replaced via a removable back plate. On the front side are the two buttons, which will be labeled up/down on the remote housing. Also at the top of the remote, the IR LED will be placed so that it will face outwards from the top. The dimensions listed on the outer edges were concluded after a decision of how big the remote should be, and how it should feel in the hand.

### 5.1.5 PCB Design Overview

For all of the boards mentioned above, it is important that we adhere to our specific board manufacturers design rule check. Usually, they will have a file that you can import into EAGLE that will check all of your dimensions to make sure that it is possible for them to manufacture. This is mainly important to avoid delays in processing/manufacturing times.

Designing the PCB's allows us to get an idea of how much room is necessary for the components, and allows us to be able to start developing the system housing. All of the boards will be done using two-layer designs, since our circuitry is not extremely complex and/or space limited. This helps reduce the overall production cost of the PCBs.

### 5.1.6 PCB Vendors and Assembly

PCB's are one of the most, if not the most, important parts of our project. The PCB's will house all of the main hardware necessary to control and run the shades once programmed with software. If any of our PCB were to fail, or have design flaws, the

product as a whole could not be able to function properly. To ensure the reliability of our product, multiple high quality PCB vendors will be explored. A minimum of at least 3 PCB's will be ordered for each of the board designs. This will give us a buffer, in case one of the PCBs were to fail or break.

When exploring the fabrication costs of the PCBs, there are many things to consider. [129] The first of which is board size. The bigger the board, the usually higher the cost. It is important not to have wasted space on the PCB where it can be avoided. However, sometimes for specific applications, like our IR remote for example, an irregular size is needed regardless of the parts space requirement. The next parameter would be number of layers. Depending on how many layers are required to route everything on your board, the price can increase. Luckily, since all of our boards are two-layer, we do not need to worry about this. Board thickness can likely affect the cost of manufacturing a PCB. The industry standard for board thickness is 1.6mm. Sometimes it is necessary to have a smaller board for space constraint reasons. Usually it does not cost extra to have a thinner board manufactured, but could cost extra to have a thicker board manufactured, say, 2mm thick. This will likely vary based on the manufacturer. Pad plating material can also affect the cost of manufacturing a PCB. The most common plating technique is leaded or lead-free HASL, which stands for Hot Air Solder Leveling, where solder is applied to the copper pad from the manufacturer. Another technique, though more expensive, is ENIG, which stands for Electroless Nickel Immersion Gold plating.

In the sections below, a few different PCB vendors will be compared. Also, a final decision on our PCB vendor will be made.

### **5.1.6.1 ExpressPCB**

Express PCB is a United States based PCB manufacturing company. They also offer their own free software that can be used to design and layout PCBs. The benefit of using their software is that you can use their built in design rule check, and get an instant quote directly from the software. Express PCB offers a prototype package of 4, two-layer boards for a flat fee. Below are a list of their specifications and prices. [130]

- Two-day lead time plus shipping time
- Board size up to 21 square inches
- \$166 for four boards plus shipping
- Tin/Lead board plating finish
- .059" FR-4 substrate
- Pad tolerance of .005 inches
- Minimum 0.021 in space between pads

### **5.1.6.2 Advanced Circuits**

Advanced Circuits or 4PCB is a United States based PCB manufacturing company. They also offer discounts for college students. Under their student program, they offer two-layer PCBs at \$33 a piece. There is no minimum number per order, which can help reduce

costs. Advanced Circuits also offers their own free PCB layout software and design rule check tool. This is very beneficial as to verify that there are no issues with the PCB before ordering. Listed below are a few of their specifications and prices. [131]

- 5 day lead time plus shipping time
- Board size up to 60 square inches
- \$33 per board – no minimum required
- .062" FR-4 substrate
- Lead-free solder finish
- Minimum 0.015 inch drill size
- Pad tolerance of 0.006 inches

### **5.1.6.3 Elecrow**

Elecrow Technology is a Chinese PCB manufacturing company, as well as electronics distributor. In addition to manufacturing PCBs, they sell a variety of open-source related hardware including Arduino, Raspberry Pi, and other open source platforms that are popular in the electronics design community. Elecrow offers 2 and 4 layer PCB manufacturing, as well as PCB assembly/population. They offer small batch (50-500 pcs) as well as prototype (5-25 pcs) quantities for as little as \$0.35 a board! Their low prices put them at an advantage over most other companies, however, being based in china can create massive lead and shipping times. Below is a list of their specifications and prices. [132]

- 10cm x 10cm max without additional charge
- 4 to 7 day lead time without rush surcharge
- 5 boards for \$4.90
- 1 oz, 35um copper
- 0.6 to 1.6 mm FR-4 substrate
- Lead free HASL finish
- Pad tolerance of .016 inches
- Minimum drill size of 0.006 inches

### **5.1.6.4 OSH Park**

OSH Park is a United States based PCB manufacturing community, in which many board designs are sent in from customers, they are panelized, and then ordered from a fabrication house. This allows for a large decrease in cost due to the high volume of ordering. Shipping occurs in 12 calendar days or less, and they offer free shipping and a few other quality benefits for free. Below is a list of some of their specifications and prices. [133]

- Two-Layer boards at \$5 per square inch – includes 3 boards

- Approximate price (based on our four board sizes) \$122
- 12 day or less lead time
- 1.6mm FR4 substrate
- 0.01 inch minimum drill size
- 1 oz copper with ENIG (Gold) finish
- Minimum 0.006 in trace clearance
- Minimum 0.006 in trace size

### **5.1.6.5 PCB Vendor Conclusion**

Each manufacturer has its own list of benefits. The main thing to compare is cost, since all of the offer most of the industry standard manufacturing specifications. Based on the information provided in the sections above, it was decided that we will go ahead and purchase our PCBs through Elecrow. There will be a slightly larger time delay because they will need to be shipped from china, however, we intend on having the first revision of our boards finalized by the end of this semester. Therefore, we can allow about a month for manufacturing and shipping time which should leave an ample amount of time for us to start our design in the spring semester. If for some reason, we need to revise one, or more, of our boards after the first run, we will most likely order from one of the United States based PCB manufacturers, to speed up lead time and shipping time.

## **5.2 Software Design**

After completing an abundant amount of research shown above, we decided that our application will be a software web application that can be accessed from any internet connected devices. This feature is really important, since many consumers wish to control their window shades directly from mobile devices, rather than physically walking over and manually move up or down their shades. What's more important is that, our web application is able to control multiple window shades directly from their mobile application regardless of it being in the kitchen or in the bedroom. Users can control any and all of their shades directly from their mobile devices. To make this routine even more pleasant, we decided we can implement or take advantage of automation. We can make this process more robust, and fast, and automatic. Our plans with software application perspective, is to make the day-to-day processes performed by users automated. For example, users can a set time or have their shades roll up or roll down automatically all done through our application. Many people would be greatly benefitted from this concept. To explain this more in detail, our software design consists a separate view, which will be called automation operation setting. In this view or page, users are offered a way to set a time for either 'Bed Time' or 'Wake Time'. 'Bed Time' usually refers to a time that users normally go to bed or a time they would like to close their blinds. Similarly, 'Wake Time' refers to time that users usually wake up. Setting time for this event make users life whole lot of easier because the moment they wake up, their bedroom or kitchen blinds are already open. With our software design, once we received the input for time from the users, we will save it into the database. Our software will monitor the clock and if the time is reached for appropriate event, then the appropriate code will be triggered, which will enable specified event to occur. Another functionality that the user may benefit from is

the ability to control in-box LEDs. This LEDs will be placed directly above the users windows. Users can control this LEDs by turning on and off whenever they please. This removes the hassle of physically moving to the Lamps or light and manually switching them on/off. With our software design and implementation, users can directly control their lightning option. Furthermore, users turn on/off LEDs as well as set color, temperature, and brightness of the LEDs. This way, they can enjoy their day-to-day activities with perfect lightning brightness. The next question we asked was; what if we could automate this process? Thus, our software design includes automation operation setting for controlling LEDs. To explain this feature more in detail, our automation operation page, will have the ability for users to set a time to have their LEDS on or off. In addition, Users can also preset their brightness level. Our software design will take the received time and brightness level and store it into our database. Our software design will monitor the clock (current time), and if users defined time is reached, then LEDs will turn on or off with given brightness level. Another functionality is that our software will be able to display the battery level of the battery installed in our box, in percentage. We also added another functionality to help accommodate our products users by adding integration with amazon Echo. This functionality is quite simple, and it works beautifully in its simplicity. Our software will let our users verbally speak commands to amazon echo, amazon echo service will route the command to our project, where command will be analyzed, and if valid, appropriate action will be taken to our shades or to the system. Our goal is to really help the user simply control the shades by integrating our product concept with amazon echo. One of best advantages is that it lets users verbally control our shades, as opposed to maneuver to our web application, which may be a bit of work. So, after careful consideration of skills at hands and research presented above, we can implement turn on/off LEDS from Amazon Echo. We can also implement rolling up or down our shades from amazon Echo. We will implement more commands, but for now with strain for time, we can only implement 2- 3 commands.

Our next question is; how will we complete the product with above features and functionalities?

First, we will build our front-end application (user interface) using several programming languages such as HTML, JavaScript, CSS, Bootstrap, Angular JS, all of which are mentioned in the research section with a brief overview of the language. In this document, we will add our initial design of front- end application. With capability of these programming languages, we are able to create our web application more user friendly, and responsive. In other words, our web application will look exactly the same from any device and it will minimize errors. With responsiveness added into our application, users are able to view our web application user interface from any devices without a problem. During development phase, we will use Visual Studio IDE to develop our web application. As we mentioned in our research section the advantages of using Visual Studio are far more helpful than any other IDEs. And with integration and plug-in offered by Visual Studio for Arduino will make it perfect to develop our code, and most importantly debug.

Next, we will build our back-end application (web-server). This will be the intermediary between the web Application UI and the MCU. For our back-end application, we will use several features like TCP/IP, sockets, HTTP Protocols such as RESTful APIs. We will be

able to communicate from UI to Web Server via internet communication. We can send request and receive response by using Restful APIs to make our application more efficient. To communicate from our web server to our PCB, we will be able to communicate with Arduino using serial communication and using appropriate baud rate.

After we complete the development phase, we intend to deploy our built application in google firebase and host it. With application configured in google firebase cloud server, our web application will act as a web site and will communicate to the server for request and response. Our research section compares and contrasts two web servers used today in the industry. Google firebase and amazon web services. We realized that Amazon web services is obviously better option between and ultimately offers more features, however, in the end, it is not cost effective. Google firebase offers enough features and offers free trial option that we can take advantage of. Since, our product does not yet require that many features, we realized that we can use google firebase as web server for hosting our web application. According firebase requirement, we can add our project directory after testing it on a offered local server. Several Web application mockups are shown *in figures 5.2.i and 5.2.ii.*

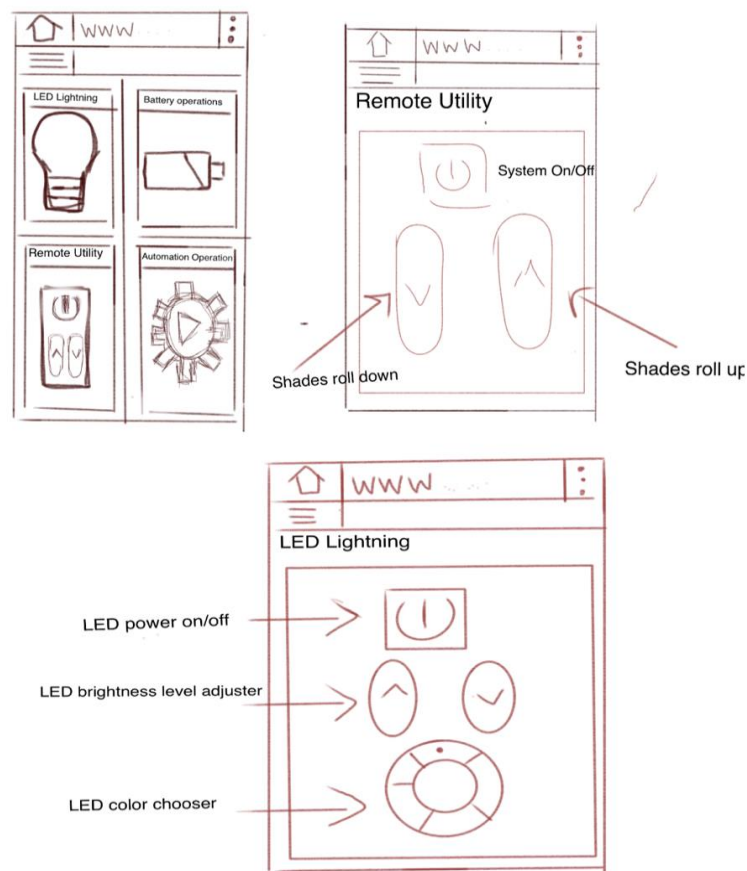
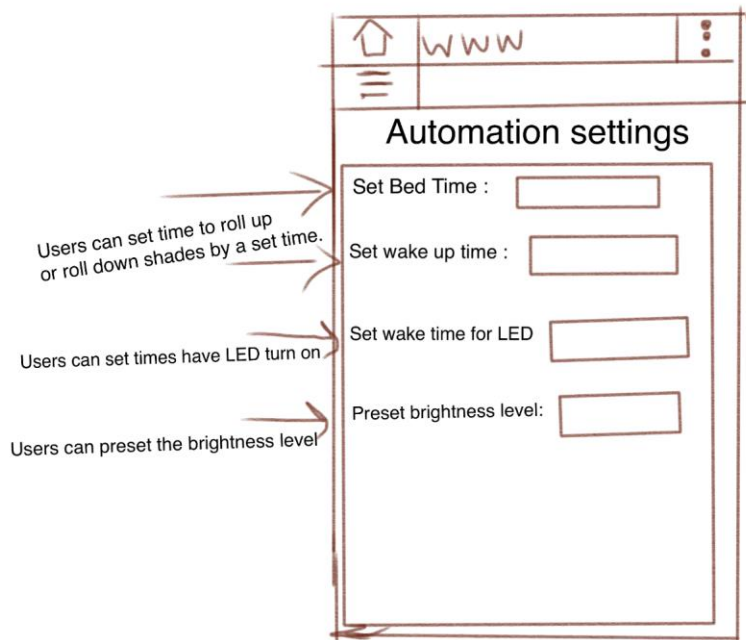

Figure 5.2.i User-Interface Mock-ups (Menu, Remote, LED)



*Figure 5.2.ii User-Interface Mock-ups (Automation Settings)*

## 6.0 Mechanical System

The mechanical system includes the motor, motor shaft, shaft brackets, and system housing. The mechanical system is still under heavy development. The housing will hold our power system PCB, control PCB, motion detector PCB, and motor system. In this section, we will discuss the different parts of the mechanical system in detail, and include rough CAD sketches developed with the help of UCF Mechanical Engineering student, Ramin Ragbir.

### 6.1 Motor Shaft and Mounting Brackets

The motor will be inside of the shades shaft itself to allow the shade to reach the full width of the window. A very rough model of the motor and shade shaft is pictured in *figure 6.1.i* below.

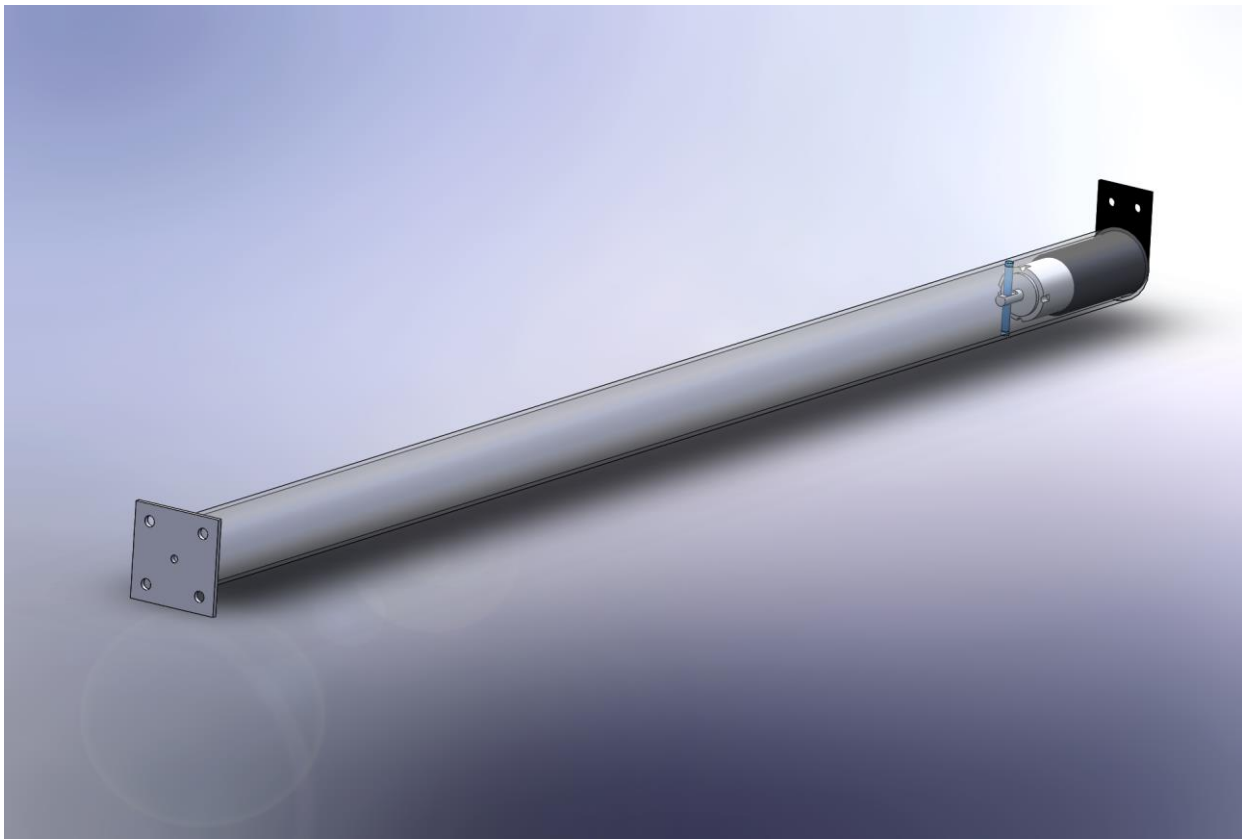

*Figure 6.1.i System Housing*

The motor has a bracket surrounding it, to attach itself to the window sill. The motor then uses a pin that is attached to the shaft, to rotate the entire shaft for the shades. The other side of the shaft will be mounted with a pin and socket support, which allows for full rotation of the shaft. These brackets will likely be machined from some sort of metal, aluminum for example, and provide the majority of the support for the entire shade

system. For the shaft we will source some sort of tubing, PVC or polyurethane for example.

## 6.2 PCB Standoffs and Part Placement

The housing will hold all of the electronic parts other than the motor. This includes the three printed circuit boards, the PIR motion sensor lens, and the battery pack. The solar panels will be attached to the face of the window, in order to maximize contact with the sun. A full view of the shades housing can be seen in *figure 6.2 i*. The enclosure has been made transparent to have a better view of the electronic parts.

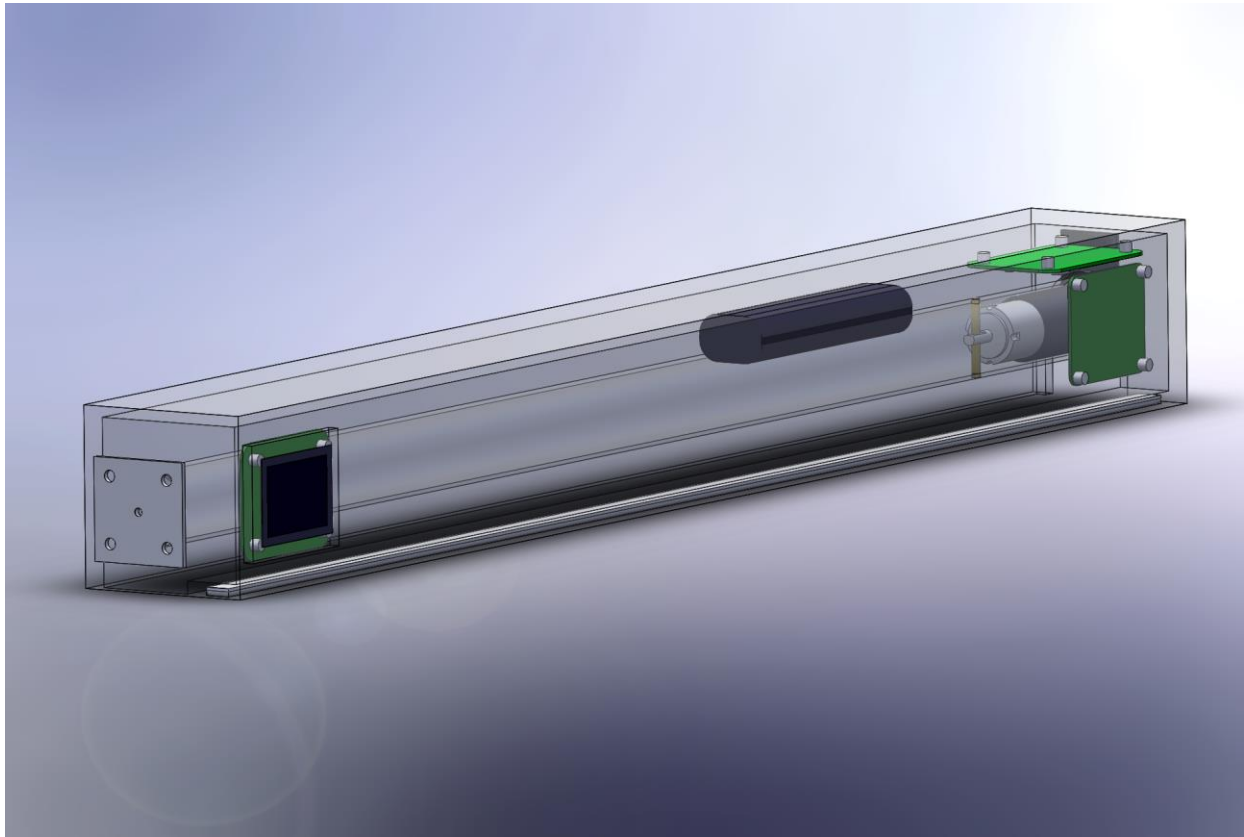
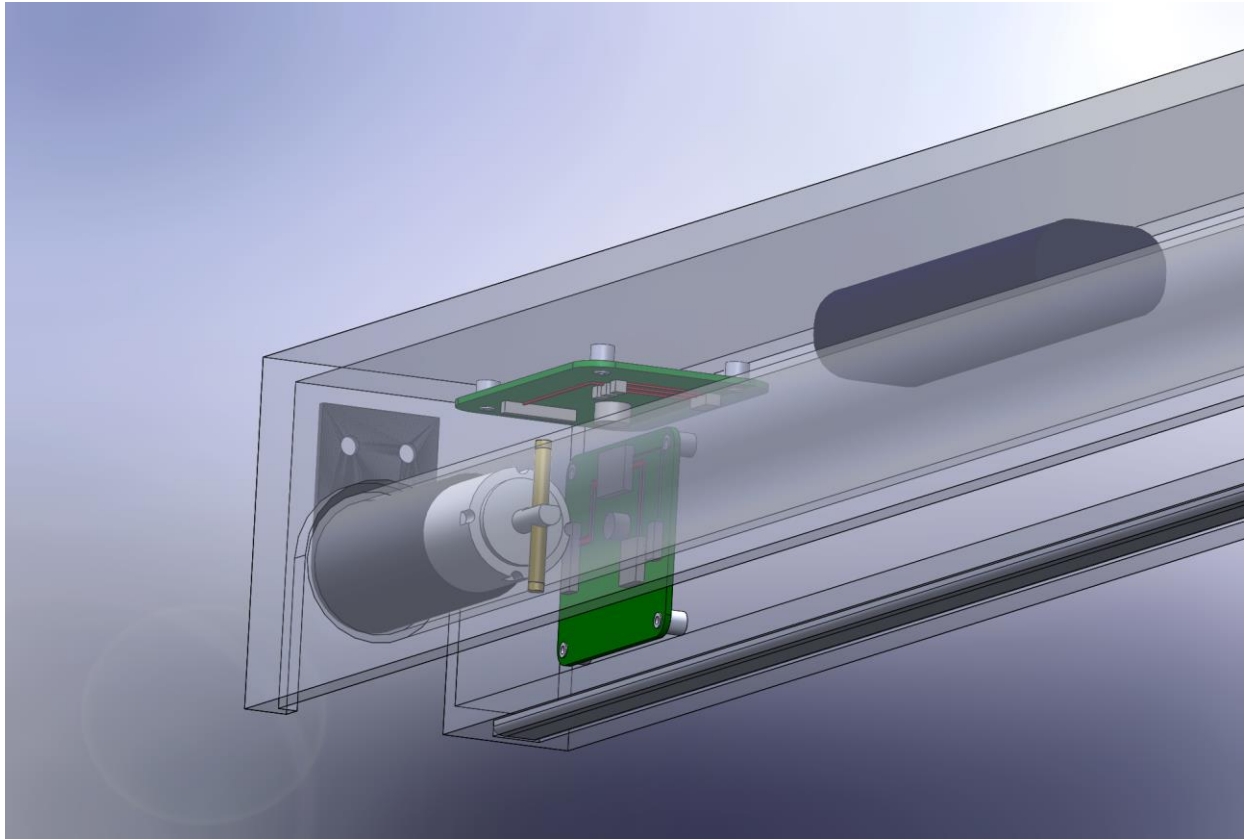

*Figure 6.2.i Electronics Placement Within System Housing*

The batteries and power board will be placed above the roller shaft, and the control board and IR board and lens will be placed on the front panel of the enclosure. The IR board will be mounted with standoffs on the outside of the lens, allowing the PIR sensor itself to be directly in the middle of the lens, at a certain distance away to utilize the lens specific focal point. The LED strip will be mounted to the bottom of the housing, in order to illuminate the blackout shades from the front.

The printed circuit boards will be mounted to the enclosure using standoffs. The standoffs will be built in to the side of the enclosure and the PCBs will be screwed in to the standoffs. A close up view of the PCBs and mock up of the parts is presented in *figure 6.2 ii*. It is

important to take into account not only the thickness of the PCB but also the thickness of the parts that will be soldered on top, in order to leave enough room so that the shaft is not rubbing against any electronics. Also visible in *figure 6.2 ii* is a closer view of the pin that will be used to rotate the shaft from the motor, and the LED strip from the bottom of the enclosure.



*Figure 6.2.ii Board Location Within System Housing*

### **6.3 System Enclosure**

It is important that the finished shades be pleasing to the eye when installed. That being said the shade enclosure must look clean and presentable. In *figure 6.3 i*, the enclosure is displayed without the transparency, to get an idea of how it will look when all the parts are buttoned up inside.

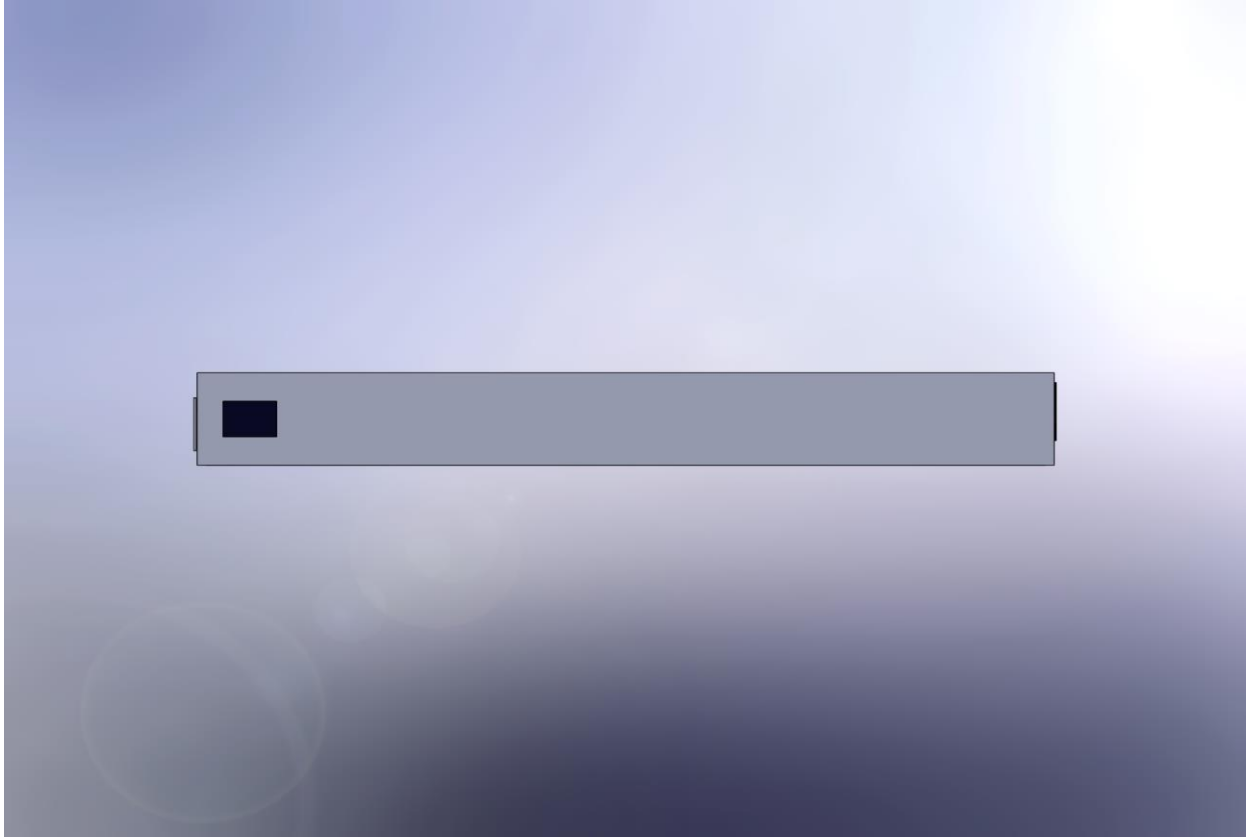

*Figure 6.3.i Infrared Location on System Housing*

On the left side is the passive infrared motion detector lens. The housing all in all is designed to look very minimal and non-obtrusive. The device should blend in with other home décor and not be an eyesore. The enclosure will likely be ordered from a manufacturer and manufactured using a hard plastic such as ABS. Choosing the right material for the enclosure is important, so that it is sturdy enough to hold all of our components, but also light enough to be supported by the brackets on either side of the shaft.

## 7.0 Testing

Testing is a critical component of any project. Ensuring that acquired components behave as expected, and in turn that designed subsystems behave accordingly, and finally that the entire system works as outlined by the requirement specifications. Of course, since the system is comprised of several subsystems, naturally, it would be beneficial to test the various subsystems separately. While it would be completely plausible to test the entire system at one time, it is not necessarily practicable, or for that matter, desirable. The entire testing process is simplified by testing small systems. The intuition being that when testing smaller subsystems errors are easier to track down as there is less going on in general. This allows for efficient troubleshooting. The idea is further extended, with subsystems that have already been verified can be added individually until eventually the entire system is properly tested. The idea being that properly working subsystems interfacing with each other should work, but if they don't it the problem could very likely be some problem with the actual interfacing of the two subsystems, as the subsystems separately have already been verified. This methodology aims to help ease the troubleshooting burden, and in effect, simplify the entirety of testing. In the following sections this testing methodology is applied first to the various subsystems: power systems, motor, motion detector, and IR remote control. These subsystems will ultimately comprise the full hardware prototype, and thus an appropriate system-wide test can be conducted.

### 7.1 Power System Testing

Once the appropriate parts arrived, testing our initial system designs began. With regard to prototype construction, the team thought it best to individually test each component/subsystem, and then begin prototyping the entire system. This way, the potential troubleshooting is greatly simplified. The power system test setup is shown in *figure 7.1.i*.

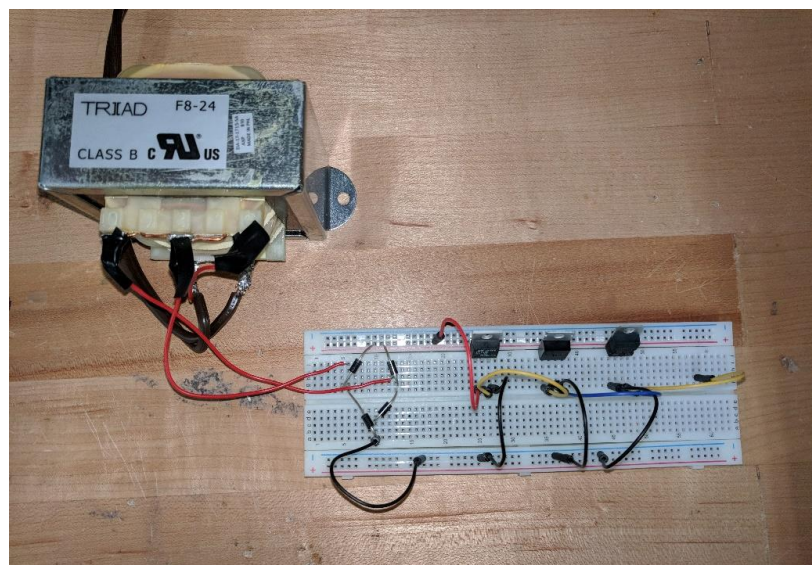
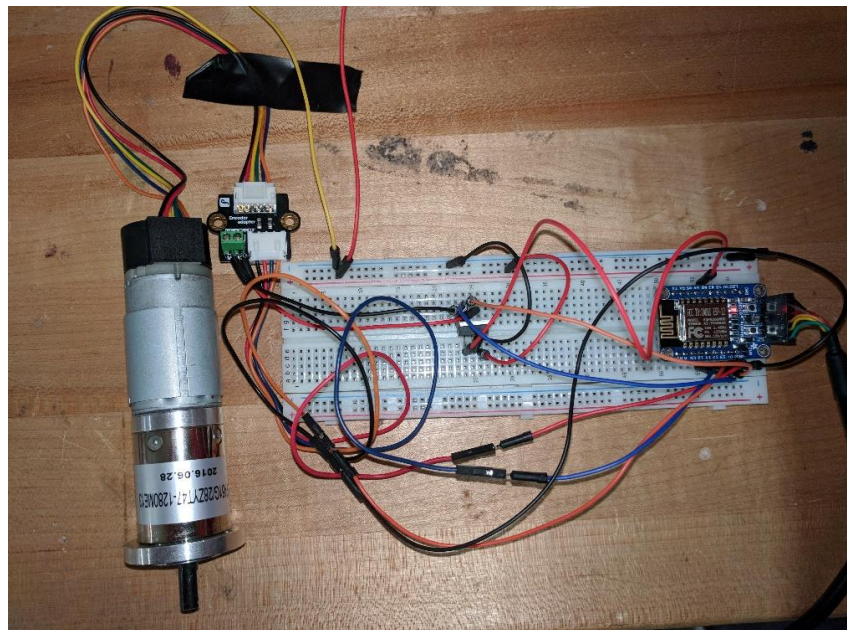

*Figure 7.1.i Power System Test*

The first subsystem tested was the AC-DC converter. For this first test, our simple system design was tested. That is, the simplest case: The transformer, the Triad Magnetics F8-24, to the rectifier, The D10XB60, then finally to a large filtering capacitor. The test began smoothly, as the subsystem was rectifying and smoothing correctly, but then a length of wire insulation burnt up and we stopped the test. Unsure of the cause of this wire failure, perhaps a faulty wire, we decided to run the test again. This time the D10XB60 burnt up. This is when we decided that there was something more fundamentally wrong with the AC-DC converter solution we were testing. It was finally determined that the output current of the Triad Magnetics F8-24 was too great for the D10XB60, and the 1N4007 rectifier arrangements. With this in mind, we began testing other subsystems, and came to the realization that our initial predictions of how much power the system would need, was greater than what our system actually needed. This meant that the Triad Magnetics F8-24 is no longer the transformer of choice for this application. Since a redesign of the AC-DC was already necessary, we decide that it will be better to pursue the flyback converter switch mode topology presented earlier. This will not only greatly reduce the size and weight of the AC-DC converter, but should also provide greater efficiency. While more complicated, this solution should ultimately yield a better result. The testing for this new AC-DC converter will also be added to this section once this section is completed.

## 7.2 Motor Testing

In our motor testing, we first began with driving the motor directly from various power rails, specifically, 12 volts, 5 volts, and 3.3 volts. The motor test setup is shown in *figure 7.2.i*. As expected the 12 volts rail powered the motor at maximum speed, while the 5 volts and 3.3 volts spin the motor at linearly lower speeds. From this test it was determined that for our application, contrary to previous assumptions, the motor running at 3.3 volts should move the blinds assembly sufficiently fast enough for our application.

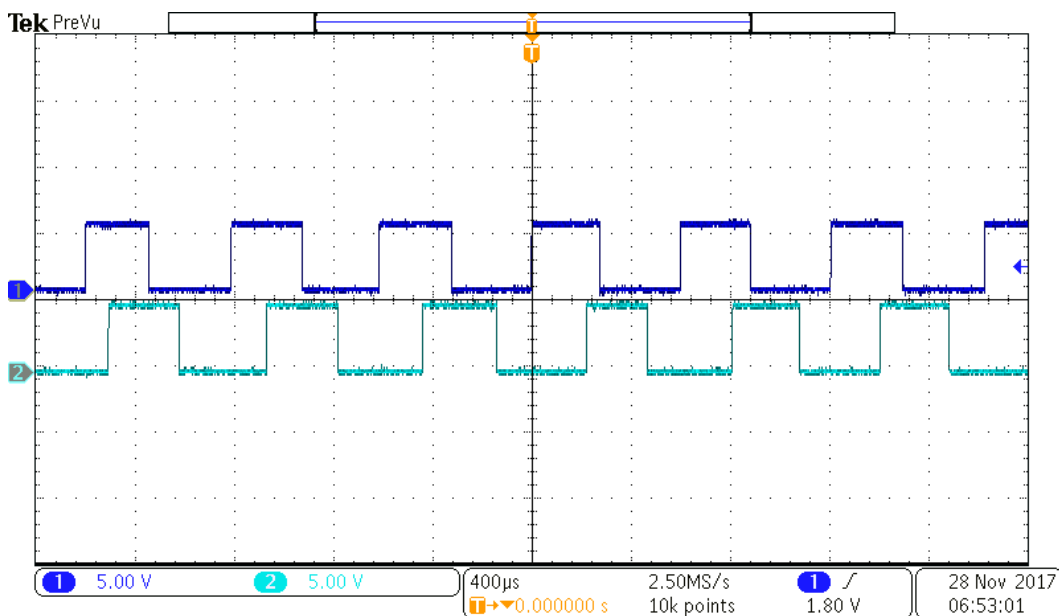

*Figure 7.2.i Motor System Test*

The next motor test was to verify that the ESP8266 microcontroller along with the TLE5206-2S motor driver, could run the motor. With our new power considerations, it was desirable that the highest voltage rail on the system was 5 volts. During the test, running the TLE5206-2S on 5 volts, the driver was not driving the motor.

The test setup was then changed to run the TLE5206-2S on 12 volts, and the driver was then able to drive the motor as expected. This leaves a choice: incorporate a 12 volts rail solely for the motor driver, or acquire an appropriate driver that will power the motor from a 5 volts or 3.3 volts rail.

With this design consideration made, the focus of the tests shifted to the motor encoder. It is our intention to use the motor encoder to lower the blinds at the user-specified height. For this test, it should be noted that the motor driver was supplied from a power supply, as the motor driver was no longer within the scope of this test. The motor has two encoders at two different location along the motors path of rotation. The goal of this test was to read these digital signals from the encoders, and generate rotational data about the motor. Through this test we were able to read the motor encoder signals on the microcontroller, and from these signals extrapolate the number of motor rotations. The motor encoder signals, as captured by an oscilloscope, are shown in *figure 7.2 ii*.



*Figure 7.2.ii Motor Encoder Waveforms*

## 7.3 LED Testing

The LED testing focused on two aspects of the LED operation: interfacing the dotStar LEDs with the ESP8266 microcontroller, and developing a simple software test for driving the dotStar LEDs in ways appropriate for our application. The LED test setup is shown in *figure 7.3.i*.

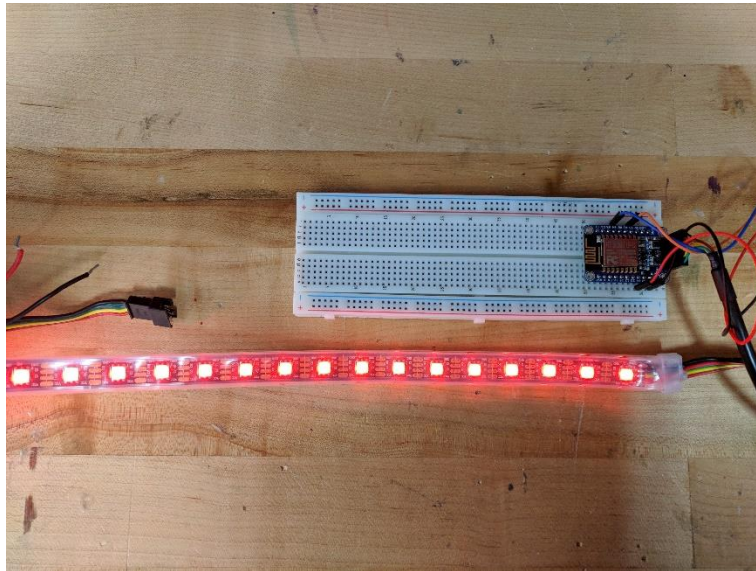

*Figure 7.3.i LED Test*

The dotStar LEDs take a data and a clock pin at 5 volts logic. The ESP8266 runs at 3.3 logic, so our initial test involved seeing if the dotStar LEDs would be able to driven from the ESP8266 without a logic level shifter. In our tests the ESP8266 was consistently able to drive the dotStar LEDs without a logic level shifter. As the project progresses, if there are future problems with the dotStar LEDs, a logic level shifter will be added.

The next LED test was meant to demonstrate that we can continuously drive the entire dotStar LED strip at a single color of our choice. The dotStar manufacturer provides a C++ object for their strip that assigns each RGB a unique address, and makes it possible to assign a single color to an RGB LED without mixing the color channels yourself. With this object, a simple test routine was written to drive the entire dotStar LED strip continuously at a single solid color. This test represents a fundamental function that will be further expanded as the software for this project matures.

Three constants were defined: the number of LEDs in the strip, the data-pin, and the clock-pin. The number of LEDs was set to 60, the data pin was set to 4 and the clock pin was set to 15. The last parameter was optional. The color data order of the DotStar strip has changed over time in different production runs. The code used uses just red, green, and blue colors which the library reassigns as needed.

For the setup loop, an if statement was first used to make sure 16 MHz was enabled on the trinket. Then two methods (`strip.begin` and `strip.show`) were used to initialize the pins

for output and turn all the LEDs off as soon as possible, respectively. The starting color red was made in a 32-bit variable. The hex number 0xFF0000 was used to give off the red color.

Lastly, in the loop function, a for loop was used to change the colors of the LED strip. Using the setPixelColor method, the colors would rotate. After this, the LED strip's brightness was adjusted using the setBrightness method. Lastly, the LEDs were turned off using the show method. This provided us a simple way of seeing the LEDs work with the Arduino microcontroller.

## 7.4 Motion Detector Testing

The OpenPIR motion detector was the next system to be tested. The objective of this test was to tune the PIR sensor sensitivity, trigger time, and range for our application. Interfacing the OpenPIR motion detector to the ESP8266 was simple, and is shown in *figure 7.4.i*.

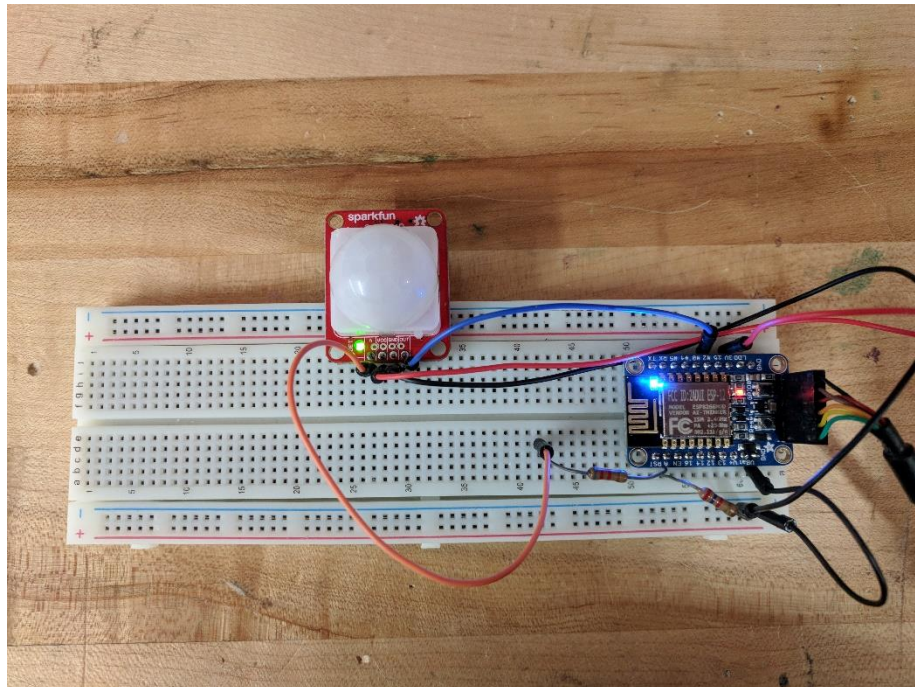
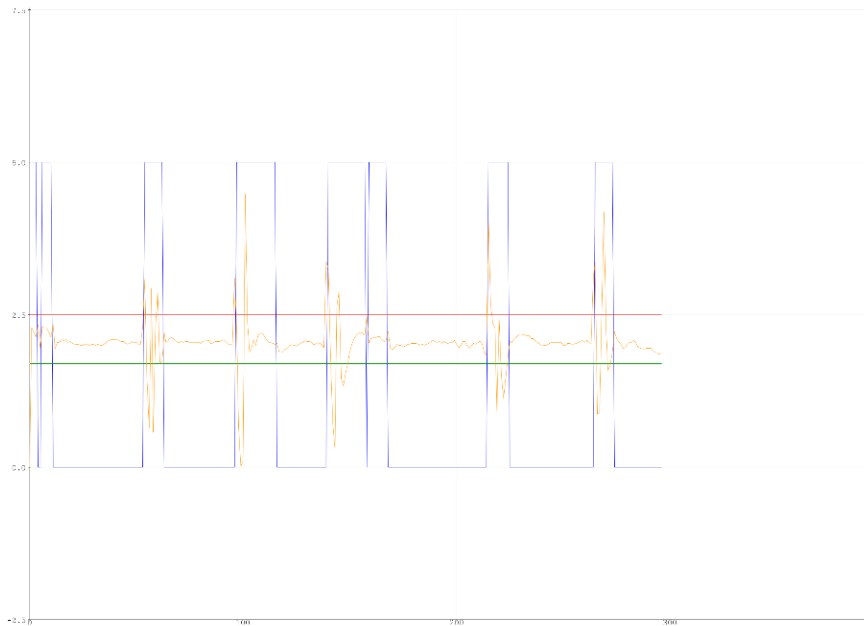

*Figure 7.4.i Motion Detector Test*

The motion detector we are using has two potentiometers that can be used to tune both the effective range of the sensor, and the amount of time that the sensor will output high. In our application, the type of motion is not important. Since this is the case, we are using a digital output from the motion detector, as the actual profile of the motion, presented in the analog signal, are extraneous for our purpose. Additionally, we do not desire our motion detector to be over discriminant. That is, for motion to be detected it, the motion should not have to be constant or exaggerated for our sensor to pick it up. This means that we want the sensor to output high for a relatively long period of time. Additionally, since our

desired range is about the length of a room, the range of the sensor has to be set quite high. It should also be noted that a different lens, that provides a wider field of view, may prove to be more appropriate than the current lens. Further investigation in real-world use is necessary first. Some detected motion signals are shown, captured on a serial monitor, are shown in *figure 7.4.ii*.

By this point, the setup function had become pretty familiar to the group. Serial.begin was set to 115200 to be used to view Analog out. The analog and digital pins were both set



*Figure 7.4.ii Motion Detector Output*

as inputs using the method `pinMode` with the constants `PIR_AOUT` and `PIR_DOUT` as inputs. The LED pin was configured as an output for indicating motion using the `pinMode` method with `LED_PIN` as an input. Lastly, `digitalWrite` was used to turn the LED off.

The loop function was split into two other functions to help organize the code. The first function was called `readDigitalValue`. The purpose of this function was to read the OUT pin and set the onboard LED to mirror the output. The second function was called `printAnalogValue`. Its purpose was to read the analog pin and print that value to the serial port.

The `readDigitalValue` function first used an integer to store what was returned by `digitalRead`. Then, two conditional statements were used that depended on what the integer was set equal to. If motion was detected the onboard LED needed to turn on. So, if the integer used was equal to a high output, the `digitalWrite` method was used to turn the LED on by setting it high as well. If the integer used was not equal to a high output, the LED was turned off by using the `digitalWrite` method to set the LED low.

In the `printAnalogValue` function, one if statement was used to print the value of the analog's value. If the last serial out added with the rate of serial printouts was less than the number of milliseconds since the Arduino board began running the current program

(given by the millis method), then the last serial out was set equal to the amount of time the millis method would return. The analog's value was then read in using the analogRead method where an unsigned integer was used to hold the value. The 10-bit analog response value had to be converted to a voltage. Using a high voltage of 5.0 volts, the response value was divided by 1024.0 and multiplied by 5.0 (to maintain scale with AOUT). This value was also converted to a float to improve accuracy. Lastly, the reading from the digital pin was printed using multiple print methods. The upper and lower limits of the voltage were first printed, followed by the actual voltage read.

## 7.5 IR Remote Control Testing

The IR remote testing was intended to explore various aspects of this IR remote: specifically, receiving and transmitting. Our envisioned IR remote only requires two commands, which leads us to believe that using an entire established pulse code scheme is excessive. A pulse code scheme for this application specifically will need to be investigated, but as this was not the focus of this testing it will not be further discussed in this section. The IR remote test setup section is shown in *figure 7.5.i*.

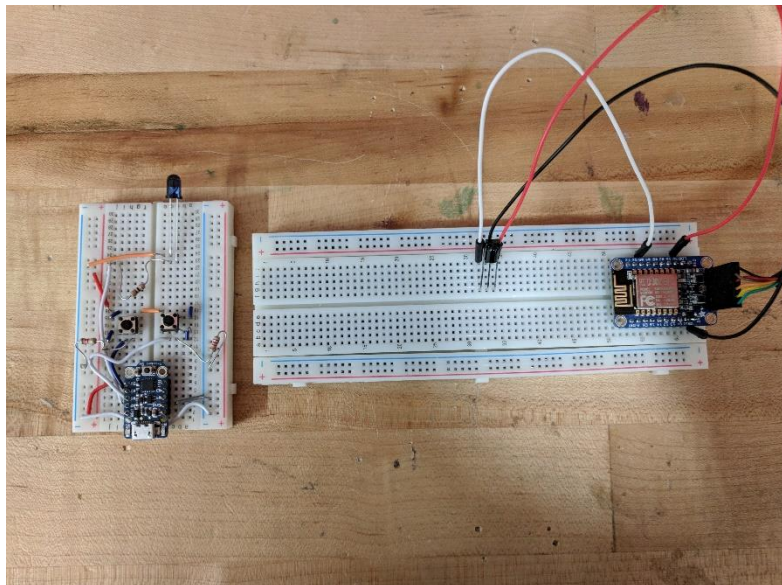
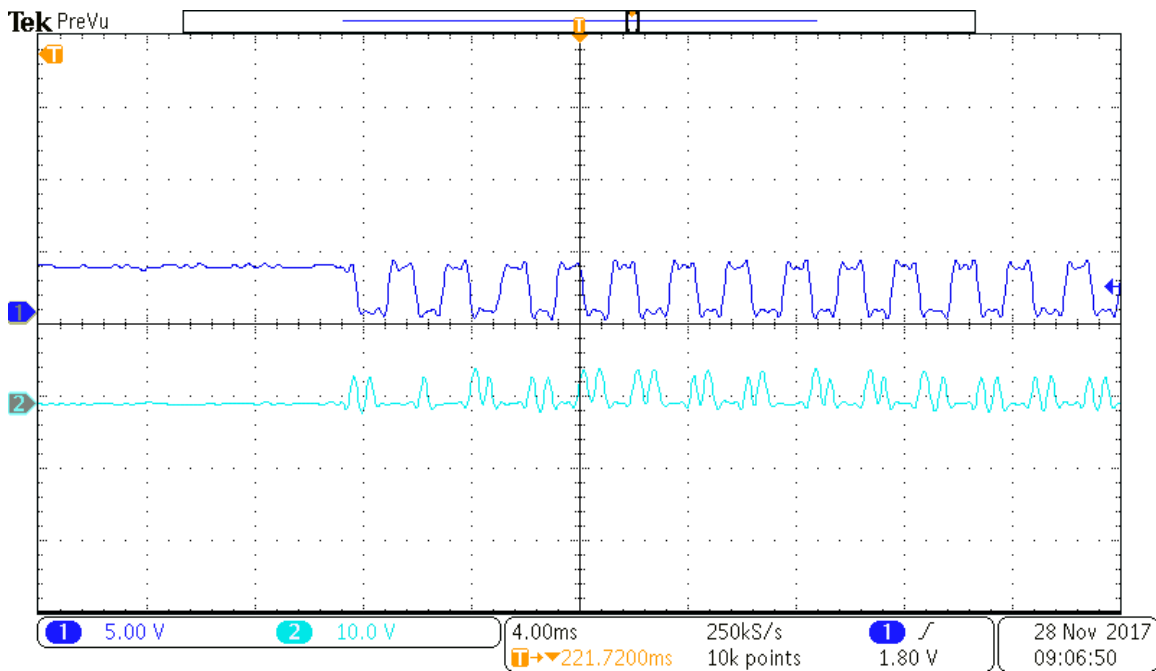

*Figure 7.5.i IR Remote Test*

The transmitting portion of this IR remote testing first focused on interfacing buttons and the IR LED with the adafruit Trinket microcontroller. In the final embodiment of this IR remote, obviously, the IR remote control will be remote, meaning unlike in this test the adafruit Trinket setup will be required to be battery operated. But again, as this was not the focus of this IR remote test, the adafruit Trinket was powered over USB. Instead, this test focused on generating and receiving pulses from buttons on the adafruit Trinket and the ESP8266 microcontrollers, respectively. Thus a simple routine was written for the Trinket which transmitted two distinct pulse trains depending on which, of two, buttons was pressed. It should be noted that while the pulse trains transmitted are not necessarily

the final pulse codes that will be used, the simple test transmitting routine will represent a fundamental building block in the eventual development of the final pulse codes to be transmitted. Of course, as with all aspects of this project, these routines will inevitably change and mature as this project progresses.

The receiving portion of this IR remote testing focused on receiving the transmitted pulses from the IR remote transmitting setup. This receiving setup is more simpler when compared with the transmitting setup, as it only requires the IR receiver to be interfaced directly with the ESP8266 microcontroller. These received IR signals are shown, as captured by an oscilloscope, in *figure 7.5.ii*. In *figure 7.5.ii*, channel 2 is the transmitted signal, while channel 1 is the received signal. This test was sufficient to prove that the IR remote receiver and transmitter will work as envisioned. This IR remote control system remains to be fully developed with an appropriate pulse code. The final pulse code is desired to be simple while also being discriminant enough to consistently distinguish between the two commands.



*Figure 7.5.ii Transmitted and Received IR Signals*

In the setup function, the two input pins were set using the method `pinMode`. The IR LED pin and built-in LED pin were set using the `pinMode` method as well. Lastly, the `begin` method was used to set the data rate in bits per second (baud) for serial data transmission as well as viewing Analog out.

The loop function utilized two functions within it to help organize the code better. These two functions were put in an if else-if conditional statement. If the first pin was read on high, the first function would be used. Otherwise, if the second pin's output was read to be high, the second function would be used. If neither of these went through the loop would repeat waiting and checking for one of the pins to return a value of high.

The first function within the if statement simply sent a value of 2000 to the pulseIR method. This would make the IR remote pulse for 2000 microseconds. The function then returns to the if statement where the built-in LED is flashed. This is done by sending a high and low to the digitalWrite method with a delay in-between each time. The statement “Button 1 pressed” was then printed to the terminal to help show the code working properly.

The second function within the else-if statement had a large amount of delay and pulseIR methods. Repeating these helped show the waveform from the IR remote on the oscilloscope. After these were finished, the function returned to the conditional statement where the built-in LED was flashed again using the same methods. The delay, however, was increased to show a difference. The statement “Button 2 pressed” was then printed to the terminal in order to help differentiate the responses available from each button.

## 7.6 Full Hardware Prototype

Once all of these subsystems tests were completed a full hardware prototype test was appropriate. This full hardware prototype testing is important because with this project a premium is placed on space and complexity. These considerations had a demonstrable effect on the choices of microcontrollers, and components in general. This System on Chip (SoC) approach was chosen because it reduces complexity while also saving space because only a single microcontroller is necessary, instead of a separate microcontroller and WiFi module. A challenge that arises from this approach is a limited number of I/O pins being reduced to that one of the SoC microcontroller selected. Thus, interfacing the various subsystems to the SoC microcontrollers becomes important. These considerations make a full hardware prototype necessary. In the full hardware prototype, the subsystems mentioned in the previous sections: AC-DC converter, motor assembly, LED strip, PIR motion detector, and the IR remote control were all interfaced to the ESP8266. This full hardware prototype ensures that the microcontroller has the appropriate number of I/O pins, but that the I/O pins work as expected when interfaced with their respective subsystems. Additionally, this full hardware prototype provides surety that none of the subsystems involved are interfering with each other. These are crucial aspects to verify because in the final product, obviously all of the described subsystems will be operating simultaneously within the same housing. The full hardware prototype is shown in *figure 7.6.i*.

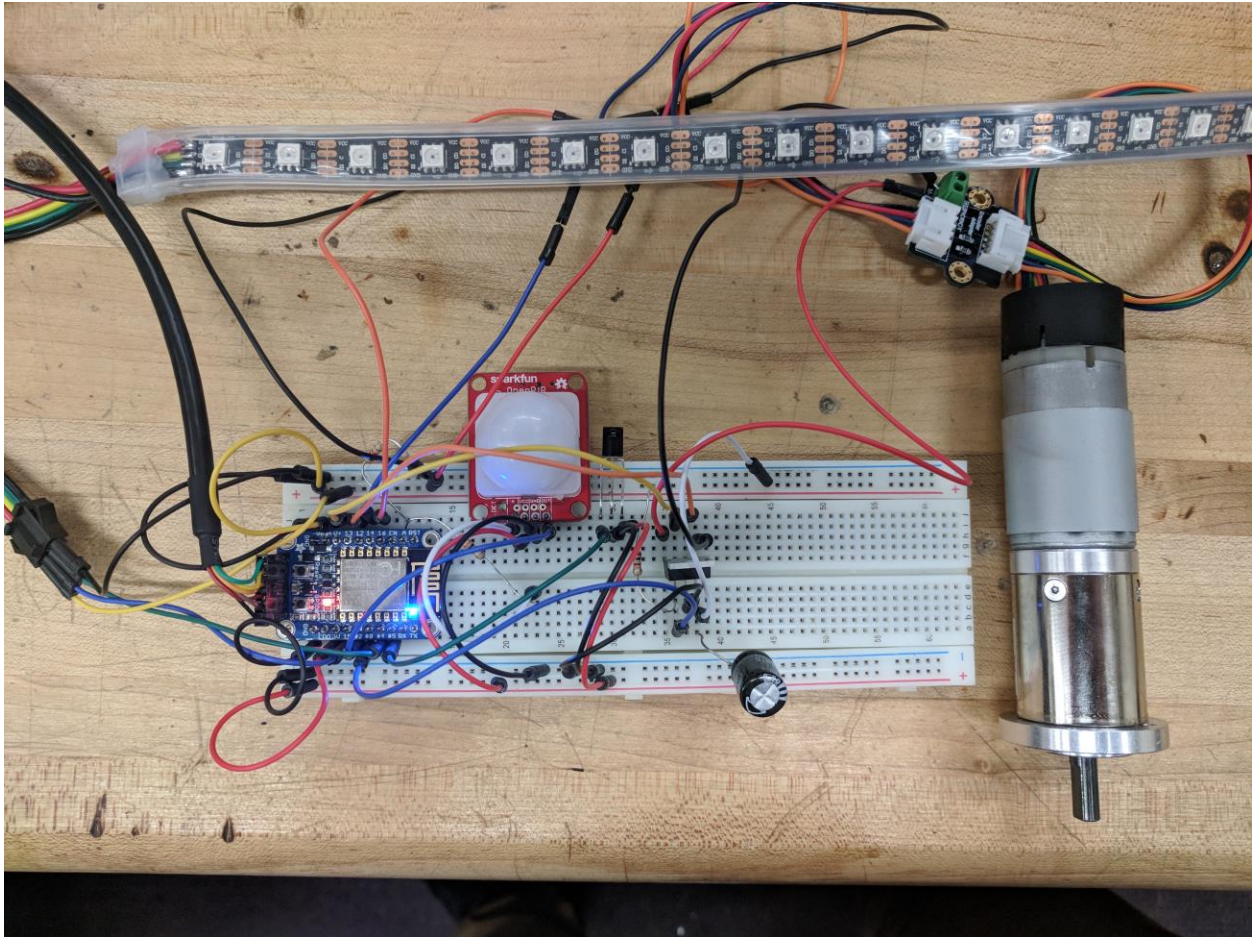

Figure 7.6.i Full Hardware Prototype

## 8.0 Administrative Content

### 8.1 Project Milestone Discussion

In order to be more proficient during this project, this group created a list of milestones that were to be achieved by a certain time. Completing each milestone on time helps ensure the group stays focused and on track. It also helps with keeping up with the due dates assigned to us. Having a short description of the milestones can help our group see the things we did right and the things we did wrong to reflect on in the future. Some of the milestones were set and updated as the project was continuously developed.

Senior Design 1, Fall Semester (August 21<sup>st</sup> – December 8<sup>th</sup>):

Week 1 (Aug 21<sup>st</sup> – Aug 25<sup>th</sup>)

- Formation of project teams.
- Creation of initial project idea.

The first week of Senior Design 1 consisted of getting to know each group member while coming up with a project for this and the following semester. One of the group members had a project that was able to be sponsored so the group decided this project would be the most appropriate. It was deemed as a realistic project that could be challenging with enough additional yet reasonable features added.

Week 2 (Aug 28<sup>th</sup> – Sep 1<sup>st</sup>)

- 1<sup>st</sup> Group meeting to discuss project and assign roles for the Initial Project Document – Divide and Conquer.

The second week we were assigned the Divide and Conquer document. This was to be a ten-page report that gave a general description of what our project was going to be. After class, our group discussed which members would be assigned which part of the document.

Week 3 (Sep 4<sup>th</sup> – Sep 8<sup>th</sup>)

- 2<sup>nd</sup> Group meeting to put together each part of the Initial Project Document.
- Completion of the Initial Project Document – Divide and Conquer. Includes completion of:
  - Executive Summary
  - Project Motivations and Goals
  - Requirement Specifications
  - House of Quality
  - Initial Project Milestones

Before submitting the document, our group met up with the finished tasks that we assigned each other and put the document together. We discussed what could possibly use improvement, fixed these issues, then turned the document in.

#### Week 4 (Sep 11th – Sep 15th)

- Attend Half Hour Meeting to discuss the Initial Project Document.

The half hour meeting had our entire group discussing the Divide and Conquer document to see if our project was worthy of being approved for Senior Design. With the amount of features and different parts being used, our project was approved. The option to make the shades hurricane proof was brought up; however, this seemed a bit outside of our goals and objectives. After this meeting the group met with each other and discussed what should be added, removed, and improved for next version of the document.

#### Week 5 (Sep 18th – Sep 22nd)

- Update the Divide and Conquer Project Document based on what was discussed at the previous meeting.

There were a few diagrams that could be improved and added into the Divide and Conquer document after reviewing it. The House of Quality also needed another engineering requirement to be added to allow our group to have something else to measure during the final presentation. We also needed to elaborate on one of the standards that were chosen.

#### Weeks 6 – 8 (Sep 25th – Oct 13th)

- Initial project research
  - Becoming more familiar with the Arduino
  - Researching the expected parts that will be used
  - Researching the development of mobile apps
- Beginning of documentation towards the final document.
  - Recording information for the Senior Design 1 Document Draft.
  - Assignment of roles and parts for the Draft as well.
  - Create the initial version of the Table of Contents for the 60-page Draft.

The initial research would allow us to have a good starting point with some information to help start the 60-page paper. This allowed the roles of each member to be more defined. Creating the table of contents at this point would also allow an easier start towards beginning to write the document. Specific parts in the table of contents were assigned to group members based on their specialties. From this point on the project milestones able to be used as goals.

#### Weeks 9 – 10 (Oct 16th – Oct 27th)

- Continuation of research and beginning of creating an in-depth design. Includes:
- Putting together each part of the Senior Design 1 Document Draft.

At this point, most of the research involved with the specific parts being used for the smart blackout shades should be completed. Once the 60-page document is reviewed, the parts can then be ordered assuming all is approved.

Week 11 (Oct 29th – Nov 3rd)

- Completion of the Senior Design 1 Document Draft. Includes completion of:
  - Existing Similar Products and Projects
  - Relevant Technologies:
    - AC-DC Converters
    - Batteries
    - Photovoltaics
    - Voltage Regulators
    - Motors and Control
    - Motion Detection
    - IR Remote Control
    - Microcontrollers
    - LEDs
    - Wireless Technologies
    - Server and Client
    - Application Development
    - Amazon Echo

The remaining research that is done should be comparing the different parts that are likely to be chosen and explaining why we are going to start with those specific ones. However, if any problems occur that require the group to use technology not already researched, this will have to be done and included later on in the project.

Week 12 (Nov 6th – Nov 10th)

- Finalize the design of the project.
- Order parts
- Begin working on 100-page submission.
- Attend Half Hour Meeting to discuss the 60-page document

Any lingering discrepancies about the project should be resolved at this point. Each member should have a clear idea of the specifics for the design of the project. After the

half hour meeting, the group will make the suggested changes to the 60-page document while beginning to work on the 100-page document that will be submitted next.

After attending the half hour meeting, we learned that there were a few things that needed to be corrected and replaced in the 60-page document. Some definitions were too obvious and unnecessary as well as some of the figures used to describe the research done. However, since the majority of the document was deemed to be sufficient, our group felt ready to order the parts after this point.

Week 13 (Nov 13th – Nov 17th)

- Completion of 100-page document. Includes:
  - Relevant Technologies: Software IDEs
  - Components and Parts Selection.
  - Design Constraints and Related Standards
    - Functionality Constraint
    - Economic Constraints
    - Time Constraints
    - Environmental/Manufacturability Constraints
    - Arduino Development Set Standards
- Receive parts and prepare and schedule a meeting to test the parts.

Part selection included: an AC-DC Converter, Batteries, a PV Panel, Voltage Regulators, a Motor, a Motor Driver, an IR Remote Control, PIR Motion Detector and Lens, a Microcontroller w/ Wi-Fi Chip, LEDs, the Shade Material, a Web-Application/Bootstrap, the Server Selection, and the Arduino IDE. All group members will have thoroughly researched and discussed what parts would best fit the design we want while being low in cost. The parts received will have to be tested soon in order to allow time to include our findings in the next document.

The standards being used will be completed and understood by each group member. Our constraints will have been discussed thoroughly and finalized. No more research on relevant technologies should be necessary.

Weeks 14 – 15 (Nov 20th – Dec 1st)

- Begin working on initial prototype.
- Test each part. Record and use date for the final documentation.
- Prepare the Final Documentation.
- Discuss results of 100-page document and make changes to it accordingly.

By now, the majority of the document will be written. Only testing the parts will have to be completed as the parts will now be in our possession. Each part will have to be tested in order to have an in-depth analysis for the final document.

Our group met up several times to test each part that was ordered. The language for programming using the Arduino IDE had to be learned. An issue we encountered during the testing phase was the upload rate not working for anything above 9,600 bits. This made uploading the programs to test on each component take about four and a half minutes. This caused the testing to take much longer than it needed to be. This issue will be looked into more in later stages since we were able to complete everything we wanted to for now.

Week 16 (Dec 4th – Dec 8th)

- Complete the Final Documentation
- Complete testing of the initial prototype.

The initial prototype should be able to be built after thorough testing is done since all the parts should be acquired and understood. All the results from testing should be finalized and completed in the final document.

Spring Semester (January 8<sup>th</sup> – April 21<sup>st</sup>):

Week 1 (Jan 8<sup>th</sup> – Jan 12<sup>th</sup>)

- Regroup with project team.
- Review and revise plans for Spring Semester.

Weeks 2 – 4 (Jan 15<sup>th</sup> – Feb 9<sup>th</sup>)

- Completion of functional prototype.
- Initial planning on improving the design and prototype.
- Work on CDR Presentation.

Weeks 5 – 8 (Feb 12<sup>th</sup> – Mar 9<sup>th</sup>)

- Order new parts if necessary.
- Work on Conference Paper.
- Continuation of testing and improving the prototype.

Weeks 9 – 11 (Mar 19<sup>th</sup> – Apr 6<sup>th</sup>)

- Beginning of Final Documents for Senior Design 2.
- Completion of the prototype

Week 12+ (Apr 9<sup>th</sup> – April 21<sup>st</sup>)

- Completion of Final Documents for Senior Design 2.
- Completion of Final Presentation and Evaluation.

## 8.2 Budget and Finance Discussion

The budget, approved by our sponsor, is a maximum of \$500 for all research and development, as well as production costs. Our group will keep a record of their spending and the sponsor will reimburse the group when the full working prototype is delivered. The sponsor has also added that they would like the product to be able to be reproduced for \$300 or less. A tentative R&D budget is listed below in *Table 8.2.i*.

*Table 8.2.i Tentative Project Budget*

<b>Item</b>	<b>Cost</b>
Shades & Housing	\$80
Motor	\$50
Main Unit PCB & Parts	\$60
Remote PCB & Parts	\$30
Motion Sensor	\$30
LED Strips	\$30
Solar Panel	\$50
Batteries	\$50
Power Supply	\$50
<b>Total</b>	<b>\$430</b>

Upon selecting and ordering parts, these prices are subject to change. The prices and distributors of these components, post ordering, will be covered in the following parts acquisition section.

### 8.2.1 Bill of Materials

A full bill of materials is presented below in *Table 8.2.ii*. This includes all of the parts and boards that consist of the electronics in our prototype. The parts will be purchased from six different manufacturers, based on price, and part availability.

Table 8.2.ii Bill of Materials

Jetsons Living Blackout Shades								
Dec-17								
Qty								
1								
Order Quantity	Total Price	Digikey	Qty	Price	Part References	Value	Package	Manufacturer Name
1	\$47.90	1738-1147-ND	1	\$47.90	Motor	12V 146RPM		DFRobot
1	\$4.21	TLE5206-2S-ND	1	\$4.21	Motor Driver	TLE5206-2S	TO220-7	Infineon Technologies
1	\$2.16	296-35391-1-ND	1	\$2.16	5V Regulator	5V 3A Linear Regulator	TO-263-4	Texas Instruments
1	\$2.16	LM1085ISX-3.3/NOPBCT-ND	1	\$2.16	3.3V Regulator	3.3V 3A Regulator	TO-263-4	Texas Instruments
1	\$0.88	NCS36000DRGOSCT-ND	1	\$0.88	U3	NCS36000	14-SOIC	ON Semiconductor
1	\$2.31	269-4955-ND	1	\$2.31	U4	PIR	TO-5-3	Zilog
1	\$3.27	PIR Board Components	1	\$3.27	C8 - C14, R9 - R16, LED 1, S2			
2	\$0.92	296-37176-1-ND	2	\$0.46	U1, U2	Buffer	SOT-23-5	Texas Instruments
1	\$0.19	1N4148WS-FDICT-ND	1	\$0.19	D1	1N4148	SOD-323	Diodes Incorporated
1	\$1.12	751-1227-ND	1	\$1.12	IR Receiver	38 KHz	TSOP38238	Vishay Semiconductor
Order Quantity	Total Price	Adafruit	Qty	Price	Part References	Value	Package	Manufacturer Name
1	\$29.95	2239	1	\$29.95	LED Strip	Black - 60 LED/m	Strip	Adafruit
1	\$17.50	390	1	\$17.50	Solar Charger	Solar Li-Ion Charger	Dev Board	Adafruit
1	\$6.95	2491	1	\$6.95	MCU	ESP-12s	ESP-12s SMD	Espressif
Order Quantity	Total Price	Jameco Electronics	Qty	Price	Part References	Value	Package	Manufacturer Name
1	\$11.90	2218610	1	\$11.90	AC-DC	12V 30 Watts	4-Pin PCB Mount	Mean Well
Order Quantity	Total Price	Amazon	Qty	Price	Part References	Value	Package	Manufacturer Name
5	\$39.95	B00HQXQIQ	5	\$7.99	Solar	6V 2W	136 x 110 mm	Sunnytech
Order Quantity	Total Price	All Battery	Qty	Price	Part References	Value	Package	Manufacturer Name
1	\$43.99	31908-01	1	\$43.99	Battery Pack	3.7V	133.5 x 38 x 19mm	Tenergy
Order Quantity	Total Price	Elecrow	Qty	Price	Part References	Value	Package	Manufacturer Name
1	\$4.90	5pcs - 2layer PCB	1	\$4.90	Power PCB	PCB	PCB	Elecrow
1	\$4.90	5pcs - 2layer PCB	1	\$4.90	Control PCB	PCB	PCB	Elecrow
1	\$4.90	5pcs - 2layer PCB	1	\$4.90	PIR PCB	PCB	PCB	Elecrow
<b>Total Price</b>	<b>\$231.55</b>							

As seen above, the total cost for all of the electronics in our prototype comes to \$231.55. This price is for 1 unit and could be greatly reduced when purchasing larger quantities. This will be explored further in section 8.2.2 Product Production Strategy. In figure 8.2.ii is a bill of materials for the IR remote. This includes the remote board, buttons, batteries, battery holders, and microcontroller.

Table 8.2.iii Bill of Materials (Remote)

Jetsons Living IR Remote								
Dec-17								
Qty								
1								
Order Quantity	Total Price	Digikey	Qty	Price	Part References	Value	Package	Manufacturer Name
1	\$0.44	1080-1080-ND	1	\$0.44	LED1	IR 940NM	5mm TH	Everlight Electronics Co Ltd
1	\$6.95	1528-1020-ND	1	\$6.95	MCU	8-bit MCU	Trinket 3.3V	Adafruit Industries
2	\$0.58	P189-ND	2	\$0.29	BT1, BT2	CR2032 3V	CR2032	Panasonic - BSG
2	\$0.20	P10.0KHCT-ND	2	\$0.10	R1, R2	10k Ω	603	Panasonic Electric Components
1	\$0.10	P10.0HCT-ND	1	\$0.10	R3	10 Ω	603	Panasonic Electric Components
Order Quantity	Total Price	SparkFun	Qty	Price	Part References	Value	Package	Manufacturer Name
2	\$1.00	COM-12992	2	\$0.50	SW1, SW2	6mm Button	SMD 6mm	SparkFun
2	\$1.90	PRT-11892	2	\$0.95	BT1, BT2	CR2032 Holder	CR2032	SparkFun
Order Quantity	Total Price	Elecrow	Qty	Price	Part References	Value	Package	Manufacturer Name
1	\$4.90	5pcs - 2layer PCB	1	\$4.90	Remote PCB	PCB	PCB	Elecrow
<b>Total Price</b>	<b>\$16.07</b>							

### 8.2.1.1 Jetsons Living Blackout Shades – Wired (AC)

The wired version of our blackout shades will consist of all of the same features, however the batteries, solar panels, and all surrounding circuitry will be neglected. The power board will consist of a switching AC-DC converter which will supply 12 volts DC to the control board. The 12 volts will then be stepped down to 5V and 3.3V to power the circuitry. The rest of the features will remain the same, according to the hardware design

in section 5.1. A detailed parts list with price break comparisons is shown below in *Table 8.2.iv*.

*Table 8.2.iv Bill of Materials with Production (Wired)*

			<b>Jetsons Living Blackout Shades Wired Price Comparison Dec-17</b>			
Qty						
100						
Order Quantity	Production Price	Part	Qty	Price	50 Pc Price Break	100 Pc Price Break
100	\$4,400.00	Motor	1	\$47.90	\$44.00	\$44.00
100	\$310.00	Motor Driver	1	\$4.21	\$3.78	\$3.10
100	\$156.00	5V Regulator	1	\$2.16	\$1.94	\$1.56
100	\$156.00	3.3V Regulator	1	\$2.16	\$1.94	\$1.56
100	\$62.00	PIR Chip	1	\$0.88	\$0.79	\$0.62
100	\$125.00	PIR Sensor	1	\$2.31	\$1.50	\$1.25
100	\$167.03	PIR Board Components	1	\$3.27	\$2.29	\$1.67
200	\$50.76	Buffer 5V Level Shift	2	\$0.46	\$0.37	\$0.25
100	\$9.32	Diode	1	\$0.19	\$0.17	\$0.09
100	\$59.40	IR Receiver	1	\$1.12	\$0.65	\$0.59
100	\$2,396.00	LED Strip	1	\$29.95	\$26.96	\$23.96
100	\$556.00	MCU	1	\$6.95	\$6.26	\$5.56
100	\$1,049.00	AC-DC Module	1	\$11.90	\$10.49	\$10.49
100	\$49.08	2layer PCB	1	\$0.95	\$0.70	\$0.49
100	\$49.08	2layer PCB	1	\$0.95	\$0.70	\$0.49
100	\$49.08	2layer PCB	1	\$0.95	\$0.70	\$0.49
<b>Total Price</b>	<b>\$9,710.22</b>					

As shown above, the total cost of parts for 100 units comes to \$9,710.22. This equates to about \$97.10 per unit, which presents a cost savings of about 58%. This is less than half of our full prototype.

### 8.2.1.2 Jetson Living Blackout Shades – Wireless

For the wireless version of our blackout shades, all of the features will remain the same except for the LEDs. The reason behind getting rid of the LEDs is because they consume too much power when illuminated for the solar charged battery to keep up with. To avoid having to replace batteries or limit the amount of time the LEDs can stay on, we made the decision to get rid of the LEDs as a whole, which will also free up a small portion of the budget. The battery and solar charging hardware does make up a lot of the cost of our prototype, therefore the cost of the wireless blackout shades is expected to be greater than the wired version. A detailed parts list with price break comparisons is shown below in *figure 8.2.v*.

Table 8.2.v Production Bill of Materials (Wireless)

				Jetsons Living Blackout Shades Wireless Price Comparison Dec-17			
Qty							
100							
Order Quantity	Production Price	Part	Qty	Price	50 Pc Price Break	100 Pc Price Break	
100	\$4,400.00	Motor	1	\$47.90	\$44.00	\$44.00	
100	\$310.00	Motor Driver	1	\$4.21	\$3.78	\$3.10	
100	\$156.00	3.3V Regulator	1	\$2.16	\$1.94	\$1.56	
100	\$62.00	PIR Chip	1	\$0.88	\$0.79	\$0.62	
100	\$125.00	PIR Sensor	1	\$2.31	\$1.50	\$1.25	
100	\$167.03	PIR Board Components	1	\$3.27	\$2.29	\$1.67	
200	\$50.76	Buffer 5V Level Shift	2	\$0.46	\$0.37	\$0.25	
100	\$9.32	Diode	1	\$0.19	\$0.17	\$0.09	
100	\$59.40	IR Receiver	1	\$1.12	\$0.65	\$0.59	
500	\$3,995.00	Solar Panel	5	\$7.99	\$7.99	\$7.99	
100	\$4,399.00	Battery Pack	1	\$43.99	\$43.99	\$43.99	
100	\$1,400.00	Solar Charger	1	\$17.50	\$15.75	\$14.00	
100	\$556.00	MCU	1	\$6.95	\$6.26	\$5.56	
100	\$49.08	2layer PCB	1	\$0.95	\$0.70	\$0.49	
100	\$49.08	2layer PCB	1	\$0.95	\$0.70	\$0.49	
100	\$49.08	2layer PCB	1	\$0.95	\$0.70	\$0.49	
Total Price	\$15,903.22						

As shown above, the total cost for 100 units is \$15,903.22. This equated to about \$159.03 per unit, which still presents a cost saving of about 29% versus our full featured prototype.

### 8.3 Parts Acquisition

As parts are ordered, they will be added to the following tables, which present a record of the parts bought from each different distributor, and the actual costs incurred. The parts chosen in Section 3.4 are the parts mentioned in this section, and as such, any further details regarding the specifics of the parts in this table should refer to the appropriate subsection of Section 3.4 for the part discussed. It is the intention of this section to outline and record the actual acquisition of parts from vendors. It is important to keep track of what parts have actually been acquired for a variety of reasons. One reason being that it allows us an easy view of what has been ordered and what has not been ordered. This helps to ensure that no parts are either accidentally not ordered, or that no part is accidentally ordered more than once. Additionally, this table also allows for a level of transparency with our sponsor. As with all things concerning with money, clarity is never understated. Section 8.3 sheds more clarity on the specifics on how much specific subsystems in the project cost, and will also help facilitate the reimbursement process. You will not find a complete list of all parts in this section due to the fact that some of the parts necessary were acquired prior to starting our project. It was determined to reuse these parts as it will help reduce cost for parts and testing, and leave room for error if a substitute part needs to be purchased in the spring semester.

In *table 8.3 i*, the first purchase is outlined, which is from the vendor known as DigiKey.

*Table 8.3.i Digikey Purchase*

<b>Item</b>	<b>Price</b>	<b>Quantity</b>	<b>Extended Price + Tax</b>
Motor	\$47.90	1	\$51.01
Motor Driver	\$4.21	2	\$8.97
Transformer	\$20.33	1	\$21.65
Bridge Rectifier	\$0.50	3	\$1.60
Diodes	\$0.299	10	\$3.18
12V Regulator	\$6.93	2	\$14.76
5V Regulator	\$0.85	2	\$1.81
3.3V Regulator	\$0.90	2	\$1.92
<b>Shipping</b>		\$9.99	
<b>TOTAL</b>		<b>\$114.88</b>	

In *table 8.3 ii*, our second purchase will be displayed. This purchase is from the electronics distributor and open-source developers Adafruit.

*Table 8.3.ii Adafruit Purchase*

<b>Item</b>	<b>Price</b>	<b>Quantity</b>	<b>Extended Price + Tax</b>
LED Strip	\$29.95	1	\$29.95
IR LED	\$0.75	2	\$1.50
IR Receiver	\$1.95	2	\$3.90
<b>Shipping</b>		\$9.16	
<b>TOTAL</b>		<b>\$44.51</b>	

The third purchase came from Amazon. These parts will be shown in *table 8.3 iii*.

*Table 8.3.iii Amazon Purchase*

<b>Item</b>	<b>Price</b>	<b>Quantity</b>	<b>Extended Price + Tax</b>
Solar Panel	\$7.99	5	\$39.95
Battery	\$9.99	1	\$9.99
Solar Charger	\$19.99	1	\$21.49
<b>Shipping</b>		\$3.04	
<b>TOTAL</b>		<b>\$74.47</b>	

To get a better idea of how we are doing on our budget so far, *table 8.3.iii* has been created, which will compare our encountered costs from acquiring our parts thus far, with our projected budget from *section 8.2*.

*Table 8.3.iv Actual Cost vs Projected Cost*

<b>Item</b>	<b>Projected Cost</b>	<b>Actual Cost To Date</b>
Shades & Housing	\$80	N/A
Motor	\$50	\$51.01
Main Unit PCB & Parts	\$60	\$34.36
Remote PCB & Parts	\$30	\$1.50
Motion Sensor	\$30	N/A
LED Strips	\$30	\$29.95
Solar Panel	\$50	\$39.95
Batteries	\$50	\$9.99
Power Supply	\$50	\$44.92
<b>Total</b>	<b>\$430</b>	<b>\$211.68</b>

As seen above, we are far under budget thus far. This is mostly due to the fact that the mechanical system costs and PCB manufacturing costs have not yet been encountered, and more than a few parts had already been obtained prior to starting the project, which we were able to use to complete our testing. These parts include, resistors and capacitors found in the laboratory, the ESP8266 development board, the PIR motion sensor board, and the trinket MCU and buttons used in the IR remote.

A photo of all the parts that have been acquired is displayed in *figure 8.3 i*. This includes one of everything mentioned in *tables 8.3 i – iii*, and a few parts that had been obtained before the start of the project.



**Stephen Fryer** is responsible for hardware programming aspect of this project. Below are few tasks he will complete at the end of the development phase of this project.

- **MCU Programming**

Programming the Arduino to communicate to each part while still retaining an efficient amount of energy consumption. Making the Arduino respond to commands given via any available device that is able and allowed to send data to the microcontroller.

- **IR Remote Programming**

Controlling how the IR Remote communicates with the microcontroller. Ensuring that it will not provide interference when used with the other available devices that allow the user to wirelessly use the shades.

**John Rossi** is responsible for PCB Design, attaining all of the major required sensor and MCU hardware components, and building up the complete PCB board with all of the components mounted. Below are few tasks he will complete during the development phase of this project.

- **IR Remote and Receiver**

Design the schematic and board for the IR remote that will be used to draw the shades without a necessary Wi-Fi connection.

- **MCU/Wi-Fi chip**

Procure the main microcontroller unit that will be used to receive commands over Wi-Fi, drive the motor and LEDs, and take in data from the PIR motion sensor, as well as the IR receiver.

- **LED Lighting**

Procure the LED light strips that will be used to illuminate the shades different colors.

- **Motion Detection**

Design the schematic and board layout for the passive infrared motion detector, as well as chose a lens to integrate the motion sensor into the system housing.

- **Motor**

Procure a low-noise motor, capable of drawing the shades up and down. The motor should be small enough in diameter, in order for the shades to not be extremely obtrusive.

**Brian Mora** is responsible for developing the power system for our circuit board (PCB). This includes the AC power, solar panel power, and batteries. Below are a few tasks he will complete during this project.

- **AC-DC Converter**

- Design and prototype an appropriate AC-DC converter that will be able to supply the power required for the system to run. This is such that a wired power solution is provided for the system.

- **Solar Panel Selection**

- Procure and implement an appropriate solar panel, and accompanying subsystems, such that the system is able to charge the batteries, while also provide appropriate solar power to the rest of the shades system.
- **Power Point Tracking**
  - Implement a power point tracking system for the solar panel, such that the solar panel can be used efficiently, and effectively to deliver power to the system in varying conditions.
- **Batteries**
  - Procure appropriate rechargeable batteries, and design and prototype a safe and efficient system to charge the batteries from the solar panel, while also being able to power the system with these batteries when the solar panel is unable to provide sufficient power.

## 8.5 Looking Forward

After the successful completion and demonstration of our prototype, we will hand off our designs to our sponsor. Our sponsor intends on using the product to integrate automated blackout shades to their smart home system. Building the product from the ground up instead of buying an already available product provides a number of benefits to them as a company. The first being customizability. The sponsor has full control over what features they would like to keep, get rid of, or add to the product, making it a great product to introduce to their customers to meet their specific needs. The second would be cost. Building a product from the ground up can usually save on the cost of production, which will ultimately result in larger profit margins, and a happier customer due to the fact that the shade price will be lower than the competition. Our intention is to provide our sponsor with a fully functional product, ready to be put in to production. The sponsor can then make any changes that they prefer, and integrate the product with their current smart home system.

## 9.0 Project Summary and Conclusion

The smart home window shades project has now been through the development and prototyping stages. Naturally, challenges have arisen, and in the case of this project these have been engineering challenges. Before our system could even be designed it first had to be defined. Our sponsor, Jetson's Living, provided a problem to be solved: smart home connected window shades. Alongside Jetson's Living requirement specifications were developed, both marketing and engineering specifications. These requirements help all parties involved understand what is to be expected from the finished product.

The smart home window shades system may sound trivial, but it comprises a culmination of various technologies, alongside cutting-edge microcontroller solutions. As with any Internet of Things device, the goal is to make the user experience as simple and convenient as possible. This idea is evident throughout our designs. This project has been developed to be as flexible and automatic as possible to aid the end-user. Additionally, reliability is of great concern for the smart home window shades system. A great deal of testing has been done to ensure that the product is a reliable one.

The design of the system presents both hardware and software design problems, and as such, both the computer engineering and electrical engineering disciplines have been required throughout the development. This project is a testament to technology integration. Each sensor by itself is simple, and straightforward, but when combined along with the rest of the system, the final product is complex.

This project is only possible because of embedded systems. Without embedded wireless modules this project would not be possible. The Internet of Things allows products, such as this smart home windows shades system, to exist. These technologies allow developers to truly solve everyday problems, and develop small, powerful products that simplify end-users' lives.

# Appendix

## Acknowledgments

Dr. Lei Wei

*Department of Electrical Engineering and Computer Science*

*University of Central Florida*

[lei.wei@ucf.edu](mailto:lei.wei@ucf.edu)

Dr. Samuel Richie

*Department of Electrical Engineering and Computer Science*

*University of Central Florida*

[richie@ucf.edu](mailto:richie@ucf.edu)

Ramin Ragbir

*Mechanical Engineering Student*

*University of Central Florida*

[rjr1204@ucf.knights.edu](mailto:rjr1204@ucf.knights.edu)

## Permissions



### PPLATO: Feedback

Hosted and maintained by:  
*The School of Mathematical and Physical Sciences, The University of Reading*

[Home](#) [Glossary](#) [Feedback](#) [News](#) [Help](#)

 PPLATO @  
University of Reading

**Feedback**  
Please use this form to submit feedback about the PPLATO website. This includes comments about the site in general, specific comments on page content and any errors or bugs you come across.

**Bugs & Errors**  
When reporting errors and bugs please supply as much information as possible so we can locate and reproduce them. As a minimum this should include the page name or module name + section number as appropriate, and also the name and version number of the web browser you are using.

**Frequently Asked Questions**  
Before reporting errors please check the FAQ section in the help page!

Also, please note that this site is still under active development. Specifically, this includes:

1. Adding new links between the FLAP modules
2. Updating links in the FLAP Glossary
3. Editing the Glossary itself

**PDF Files**  
The original PDF files (FLAP modules produced by the Open University and the Hyper-FLAP modules produced by Salford and Plymouth universities) are still accessible from this website **HERE**. We have noticed a small number of errors in these, but they cannot be corrected as the PDF files are not under our control. However, they have been fixed in their web page versions.

**Please enter your contact details in case we need to reply:**

Your name:

Your e-mail address:

Subject of feedback:

Your feedback or enquiry:

Thank you,  
Brian Mora

Check this box if you want a copy of your feedback sent to your e-mail address.

Request to Use *figure 3.2.x* – Brian Mora



Request to Use *figures 3.2.i, 3.2.ii, 3.2.iii* – Brian Mora

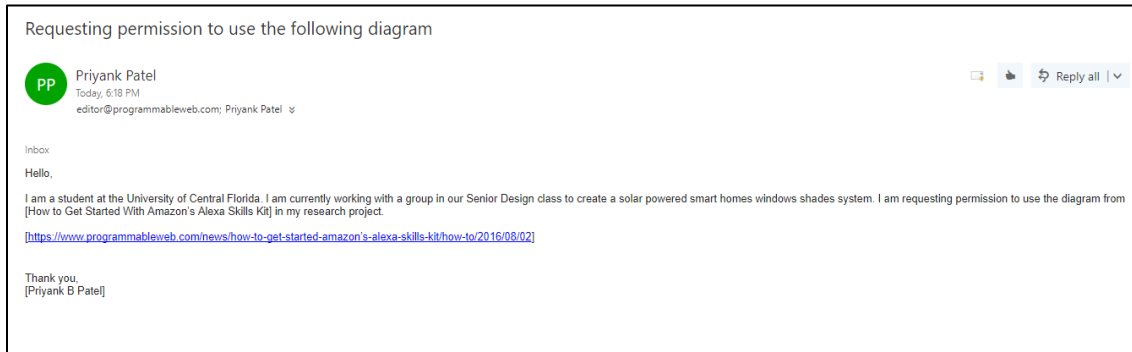

Request to Use *figure 3.2xvii and figure 3.2xviii* – Priyank Patel

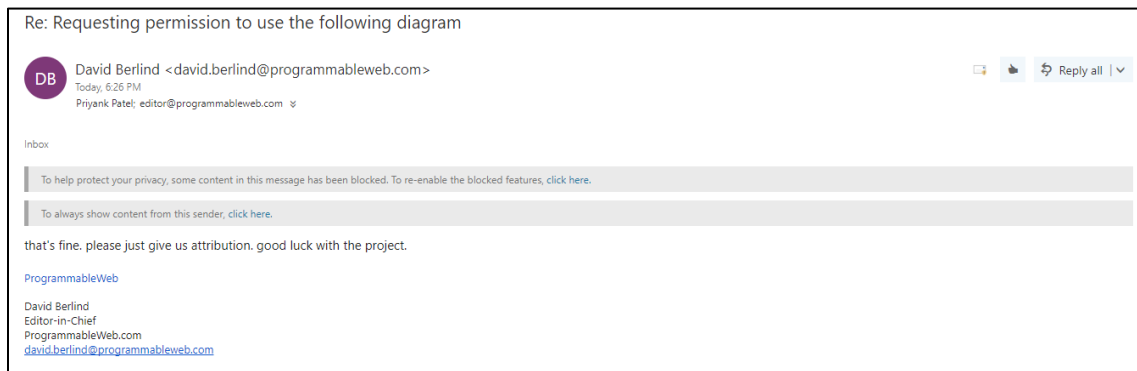

Permission to Use *figure 3.2xvii and figure 3.2xviii* – Priyank Patel

Requesting permission to use the following diagram

 Priyank Patel  
 Today, 7:02 PM  
 support@w3schools.com; Priyank Patel

Sent Items

Hello,

I am a student at the University of Central Florida. I am currently working with a group in our Senior Design class to create a solar powered smart homes windows shades system. I am requesting permission to use the diagram from [HTML Color Picker] in my research project.

[https://www.w3schools.com/colors/colors\\_picker.asp](https://www.w3schools.com/colors/colors_picker.asp)

Thank you,  
 [Priyank B Patel]

Request to Use *figure 3.2.xviii* – Priyank Patel

**Your message has been sent**

Thank you for contacting Amazon Mobile App Distribution Support Team.  
 Our team will respond as soon as possible.

<b>From</b>	pri4216@knights.ucf.edu
<b>To</b>	Amazon Appstore Customer Service
<b>Subject</b>	General Feedback
<b>Message</b>	Hello, I am a student at the University of Central Florida. I am currently working with a group in our Senior Design class to create a solar powered smart homes windows shades system. I am requesting permission to use the diagram from [Design Process] in my research project. [ <a href="https://developer.amazon.com/designing-for-voice/design-process/">https://developer.amazon.com/designing-for-voice/design-process/</a> ] Thank you, [Priyank B Patel]

Request to Use *figure 3.2.xviii* – Priyank Patel



**John Rossi**  
 Today, 11:08 AM  
 Marshall@MarshallBrain.com

Hello,

My name is John Rossi, I am a student at the University of Central Florida. I am currently working with a group in our Senior Design class to create a solar powered smart home window shades system. I am writing to you to request permission to use the figure on page 2 of your article "How Electric Motors Work" from howstuffworks.com.

<https://electronics.howstuffworks.com/motor1.htm>

---



[Inside an Electric Motor - How Electric Motors Work ...](#)  
[electronics.howstuffworks.com](https://electronics.howstuffworks.com)

Inside an Electric Motor - You might be surprised to find out just how much work is done by electric motors. They're everywhere! You'll find them in your car, your ...

---

Thank you very much,  
John Rossi

Request to Use *figure 3.2.v* – John Rossi



**John Rossi**  
 Today, 10:51 AM  
 BatteryU@cadex.com

Hello,

My name is John Rossi, I am a student at the University of Central Florida. I am currently working with a group in our Senior Design class to create a solar powered smart homes windows shades system. I am writing to you to request permission to use figure 3 from BU-409: Charging Lithium-Ion in the lithium-ion battery research section of my report.

[http://batteryuniversity.com/learn/article/charging\\_lithium\\_ion\\_batteries](http://batteryuniversity.com/learn/article/charging_lithium_ion_batteries)

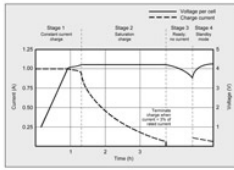
---



[Charging Lithium-Ion Batteries – Battery University](#)  
[batteryuniversity.com](http://batteryuniversity.com)

Review simple guidelines for charging Lithium-based batteries and prolong battery life such as; a portable device should be turned off while charging and more.

---

Thank you very much,  
John Rossi

Request to Use *figure 3.2.iv* – John Rossi

Hi John,

Yes, you may use the material as requested. Please cite sources where appropriate.

Regards,

John Bradshaw - Marketing Communications Manager  
Cadex Electronics Inc. | [www.cadex.com](http://www.cadex.com)  
Vancouver | Minneapolis | Frankfurt  
Tel: +1 604 231-7777 x319 | Toll Free: 1-800 565-5228

Follow us on Twitter: [twitter.com/cadexelectronic](https://twitter.com/cadexelectronic)  
Join us on Facebook: [facebook.com/cadexelectronics](https://facebook.com/cadexelectronics)  
Add us on Google+: [plus.google.com/+Cadex](https://plus.google.com/+Cadex)

### Permission to Use *figure 3.2.iv* – John Rossi



John Rossi

Today, 11:18 AM

[university@microchip.com](mailto:university@microchip.com)



Reply all | v

Hello,

My name is John Rossi, I am a student at the University of Central Florida. I am currently working with a group in our Senior Design class to create a solar powered smart home window shades system. I am writing to you to request permission to use a few figures from a MicroChip publication (AN905) titled Brushed DC Motor Fundamentals, written by former Microchip employee Reston Condit. The figures are: Figure 7, Figure 8, Figure 9, and Figure 10.

<http://ww1.microchip.com/downloads/en/appnotes/00905a.pdf>

---

### Brushed DC Motor Fundamentals - Microchip Technology

[ww1.microchip.com](http://ww1.microchip.com)

AN905 DS00905A-page 2 2004 Microchip Technology Inc. Brushes and Commutator Unlike other electric motor types (i.e., brushless DC, AC induction), BDC motors do not ...

---

Thank you very much.

- John Rossi

### Request to Use *figure 3.2.vi* *3.2.vii*, *3.2.viii*, *3.2.ix* – John Rossi

Hello,

I am a student at the University of Central Florida. I am currently working with a group in our Senior Design class to create a solar powered smart homes windows shades system. I am requesting permission to use the Wireless Router Network Diagram from "Gallery of Home Network Diagrams" in my research project.

<https://www.lifewire.com/home-network-diagrams-4064053>

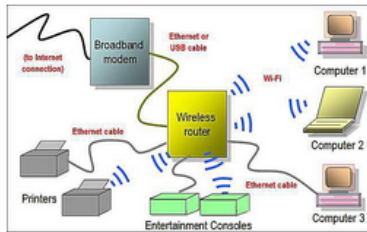

## Network Diagram Layouts - Home Network Diagrams

[www.lifewire.com](http://www.lifewire.com)

This collection of home network diagrams covers both Ethernet and wireless layouts. Network diagrams with routers, access points, printers and entertainment consoles ...

Thank you,  
Stephen Fryer

*Request to use Figure 3.2.xiv – Stephen Fryer*



Stephen Fryer

Yesterday, 9:34 PM  
sales@icpdas-usa.com

Reply all | v

Hello,

I am a student at the University of Central Florida. I am currently working with a group in our Senior Design class to create a solar powered smart homes windows shades system. I am requesting permission to use the diagram that shows the three topologies used in the ZigBee standard in my research project.

[http://www.icpdas.com/root/product/solutions/industrial\\_wireless\\_communication/wireless\\_solutions/zigbee\\_introduction.html](http://www.icpdas.com/root/product/solutions/industrial_wireless_communication/wireless_solutions/zigbee_introduction.html)

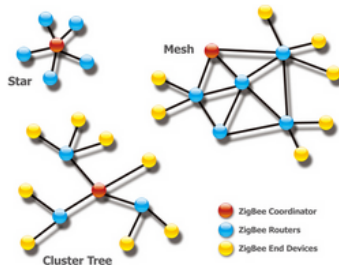

## What is ZigBee? - ICP DAS

[www.icpdas.com](http://www.icpdas.com)

ZigBee wireless communication is focused on control and automation, while Bluetooth is focused on connectivity between laptops, PDA's, and the like, as well as more ...

Thank you,  
Stephen Fryer

*Request to use Figure 3.2.xvi – Stephen Fryer*

## References

- [1] R. M. Ford and C. S. Coulston, Design for Electrical and Computer Engineers, New York: McGraw-Hill, 2008.
- [2] Pragmatic Marketing, "Writing the Market Requirements Document," November 2011. [Online]. Available: <https://pragmaticmarketing.com/resources/articles/writing-the-market-requirements-document>. [Accessed 20 October 2017].
- [3] Wikipedia, "Quality Function Deployment," [Online]. Available: [https://en.wikipedia.org/wiki/Quality\\_function\\_deployment](https://en.wikipedia.org/wiki/Quality_function_deployment). [Accessed 1 November 2017].
- [4] Lutron, "Our Story," [Online]. Available: <http://www.lutron.com/en-US/Company-Info/>. [Accessed 2017 27 October].
- [5] Pella, "The Pella Story," [Online]. Available: <http://www.pella.com/history/>. [Accessed 27 October 2017].
- [6] Somfy Systems, "The Somfy Story," [Online]. Available: <https://www.somfysystems.com/about-us/our-story/>. [Accessed 27 October 2017].
- [7] D. Jordan, S. Diamond, S. Walsh and A. Coleman, "Smart Blinds," [Online]. Available: <http://www.eecs.ucf.edu/seniordesign/su2015fa2015/g11/>. [Accessed 1 November 2017].
- [8] Texas Instruments, "WEBENCH Designer," [Online]. Available: [http://www.ti.com/design-tools/overview.html?DCMP=sva\\_web\\_webdesigncntr\\_en&HQS=sva-web-webdesigncntr-vanity-lp-en](http://www.ti.com/design-tools/overview.html?DCMP=sva_web_webdesigncntr_en&HQS=sva-web-webdesigncntr-vanity-lp-en). [Accessed 7 November 2017].
- [9] Texas Instruments, "WEBENCH Designer," [Online]. Available: [https://webench.ti.com/webench5/power/webench5.cgi?DesignId=9&base\\_pn=UCC28740](https://webench.ti.com/webench5/power/webench5.cgi?DesignId=9&base_pn=UCC28740). [Accessed 7 November 2017].
- [10] Texas Instruments, "WEBENCH Designer," [Online]. Available: [https://webench.ti.com/webench5/power/webench5.cgi?DesignId=11&base\\_pn=UC2813-0](https://webench.ti.com/webench5/power/webench5.cgi?DesignId=11&base_pn=UC2813-0). [Accessed 7 November 2017].
- [11] Texas Instruments, "WEBENCH Designer," [Online]. Available: [https://webench.ti.com/webench5/power/webench5.cgi?DesignId=8&base\\_pn=UCC28630](https://webench.ti.com/webench5/power/webench5.cgi?DesignId=8&base_pn=UCC28630). [Accessed 7 November 2017].

- [12] I. Buchmann, "BU-409: Charging Lithium-Ion," 9 May 2017. [Online]. Available: [http://batteryuniversity.com/learn/article/charging\\_lithium\\_ion\\_batteries](http://batteryuniversity.com/learn/article/charging_lithium_ion_batteries). [Accessed 31 October 2017].
- [13] Wikipedia, "Photovoltaic Effect," [Online]. Available: [https://en.wikipedia.org/wiki/Photovoltaic\\_effect](https://en.wikipedia.org/wiki/Photovoltaic_effect). [Accessed 24 October 2017].
- [14] Wikipedia, "Theory of solar cells," [Online]. Available: [https://en.wikipedia.org/wiki/Theory\\_of\\_solar\\_cells#Simple\\_explanation](https://en.wikipedia.org/wiki/Theory_of_solar_cells#Simple_explanation). [Accessed 24 October 2017].
- [15] Wikipedia, "Maximum Power Point Tracking," [Online]. Available: [https://en.wikipedia.org/wiki/Maximum\\_power\\_point\\_tracking](https://en.wikipedia.org/wiki/Maximum_power_point_tracking). [Accessed 24 October 2017].
- [16] D. Neaman, in *Microelectronics-Circuit Analysis and Design, 4th edition*, McGraw-Hill, 2007.
- [17] WikiMedia Foundation, "Electric Motor," 18 October 2017. [Online]. Available: [https://en.wikipedia.org/wiki/Electric\\_motor#Motor\\_construction](https://en.wikipedia.org/wiki/Electric_motor#Motor_construction). [Accessed 28 October 2017].
- [18] Motion Control Online Marketing Team, "Brushed DC Motors Vs. Brushless DC Motors," 24 January 2017. [Online]. Available: <https://www.motioncontrolonline.org/blog-article.cfm/Brushed-DC-Motors-Vs-Brushless-DC-Motors/24>. [Accessed 28 October 2017].
- [19] Reston Condit, Microchip Technology Inc., "Brushed DC Motor Fundamentals," 26 January 2004. [Online]. Available: <http://ww1.microchip.com/downloads/en/appnotes/00905a.pdf>. [Accessed 30 October 2017].
- [20] Padmaraja Yedamale, Microchip Technology Inc., "Brushless DC (BLDC) Motor Fundamentals," 28 July 2003. [Online]. Available: <http://electrathonoftampabay.org/www/Documents/Motors/Brushless%20DC%20%28BLDC%29%20Motor%20Fundamentals.pdf>. [Accessed 30 October 2017].
- [21] Wikipedia, "Black-body Radiation," [Online]. Available: [https://en.wikipedia.org/wiki/Black-body\\_radiation](https://en.wikipedia.org/wiki/Black-body_radiation). [Accessed 24 October 2017].
- [22] Adafruit, "PIR Motion Sensor," [Online]. Available: <https://learn.adafruit.com/pir-passive-infrared-proximity-motion-sensor/how-pirs-work>. [Accessed 24 October 2017].

- [23] Wikipedia, "Fresnel lens," [Online]. Available: [https://en.wikipedia.org/wiki/Fresnel\\_lens](https://en.wikipedia.org/wiki/Fresnel_lens). [Accessed 24 October 2017].
- [24] Wikipedia, "Doppler Effect," [Online]. Available: [https://en.wikipedia.org/wiki/Doppler\\_effect](https://en.wikipedia.org/wiki/Doppler_effect). [Accessed 24 October 2017].
- [25] Wikipedia, "Motion Detector," [Online]. Available: [https://en.wikipedia.org/wiki/Motion\\_detector](https://en.wikipedia.org/wiki/Motion_detector). [Accessed 24 October 2017].
- [26] Adafruit, lady ada, "IR Sensor," [Online]. Available: <https://learn.adafruit.com/ir-sensor/overview>. [Accessed 25 October 2017].
- [27] Vishay Semiconductors, "Data Formats for IR Remote Control," August 2013. [Online]. Available: <https://www.vishay.com/docs/80071/dataform.pdf>. [Accessed 27 October 2017].
- [28] T. Agarwal, "Understanding about RISC and CISC Architectures," EIProCus, [Online]. Available: <https://www.elprocus.com/what-is-risc-and-cisc-architecture-and-their-workings/>. [Accessed 14 November 2017].
- [29] A. Kalnoskas, "Microcontroller Tips," 15 May 2017. [Online]. Available: <http://www.microcontrollertips.com/risc-architecture-instruction-set-architecture/>. [Accessed 14 November 2017].
- [30] Yash, "Serial Communication - Introduction," maxEmbedded.com, 13 September 2013. [Online]. Available: <http://maxembedded.com/2013/09/serial-communication-introduction/>. [Accessed 14 November 2017].
- [31] Computer Hope, "TCP/IP," 20 July 2017. [Online]. Available: <https://www.computerhope.com/jargon/t/tcpip.htm>. [Accessed 14 November 2017].
- [32] Oracle, "What is a socket?," [Online]. Available: <https://docs.oracle.com/javase/tutorial/networking/sockets/definition.html>. [Accessed 15 November 2017].
- [33] M. Vaqqas, "RESTful Web Services: A Tutorial," [Online]. Available: <http://www.drdoobs.com/web-development/restful-web-services-a-tutorial/240169069> . [Accessed 14 November 2017].
- [34] Sparkfun, "Diodes," [Online]. Available: <https://learn.sparkfun.com/tutorials/light-emitting-diodes-leds>. [Accessed 1 November 2017].
- [35] Wikipedia, "Light-emitting diode," [Online]. Available: [https://en.wikipedia.org/wiki/Light-emitting\\_diode](https://en.wikipedia.org/wiki/Light-emitting_diode). [Accessed 2 November 2017].

- [36] N. Poole, "Light-Emitting Diodes (LEDs)," [Online]. Available: <https://learn.sparkfun.com/tutorials/light-emitting-diodes-leds>. [Accessed 1 November 2017].
- [37] T. Harris and W. Fenlon, "How Light Emitting Diodes Work," [Online]. Available: <https://electronics.howstuffworks.com/led.htm>. [Accessed 1 November 2017].
- [38] Wikipedia, "Wi-Fi," [Online]. Available: <https://en.wikipedia.org/wiki/Wi-Fi>. [Accessed 2 November 2017].
- [39] Wikipedia, "Wireless Access Point," [Online]. Available: [https://en.wikipedia.org/wiki/Wireless\\_access\\_point](https://en.wikipedia.org/wiki/Wireless_access_point). [Accessed 2 November 2017].
- [40] J. Baker, "What is Wi-Fi? Explained in Simple Terms," [Online]. Available: <https://3g.co.uk/guides/what-is-wi-fi-explained-in-simple-terms>. [Accessed 2 November 2017].
- [41] Aakai1056, "What is WiFi and How Does it Work?," [Online]. Available: <http://ccm.net/faq/298-what-is-wifi-and-how-does-it-work>. [Accessed 2 November 2017].
- [42] C. Hoffman, "Wi-fi vs. Ethernet: How Much Better Is a Wired Connection?," [Online]. Available: <https://www.howtogeek.com/217463/wi-fi-vs.-ethernet-how-much-better-is-a-wired-connection/>. [Accessed 2 November 2017].
- [43] A. Shekhar, "Wi-Fi vs Ethernet: Which Inter Connection Is Better and Why?," [Online]. Available: <https://fossbytes.com/wi-fi-vs-ethernet-comparison-features/>. [Accessed 2 November 2017].
- [44] Wikipedia, "Bluetooth," [Online]. Available: <https://en.wikipedia.org/wiki/Bluetooth>. [Accessed 2 November 2017].
- [45] B. Mitchell, "What Is Bluetooth Wireless Networking?," [Online]. Available: <https://www.lifewire.com/definition-of-bluetooth-816260>. [Accessed 2 November 2017].
- [46] Wikipedia, "Zigbee," [Online]. Available: <https://en.wikipedia.org/wiki/Zigbee>. [Accessed 2 November 2017].
- [47] E. Betters and C. Hall, "What is Zigbee and why is it important for your smart home?," [Online]. Available: <http://www.pocket-lint.com/news/129857-what-is-zigbee-and-why-is-it-important-for-your-smart-home>. [Accessed 2 November 2017].

- [48] M. Rouse, "Zigbee," [Online]. Available: <http://internetofthingsagenda.techtarget.com/definition/ZigBee>. [Accessed 2 November 2017].
- [49] I. Poole, "ZigBee Technology Tutorial," [Online]. Available: <http://www.radio-electronics.com/info/wireless/zigbee/zigbee.php>. [Accessed 2 November 2017].
- [50] Wikipedia, "Z-Wave," [Online]. Available: : <https://en.wikipedia.org/wiki/Z-Wave> . [Accessed 15 November 2017].
- [51] S. Sattel, "WiFi vs. Bluetooth: Wireless Electronics Basics," AutoDesk, [Online]. Available: <https://www.autodesk.com/products/eagle/blog/wifi-vs-bluetooth-wireless-electronics-basics/>. [Accessed 14 November 2017].
- [52] TechTarget, "client/server (client/servermodel, client/server architecture)," [Online]. Available: <http://searchnetworking.techtarget.com/definition/client-server>. [Accessed 30 October 2017].
- [53] Tutorials Point, "HTTP - Overview," [Online]. Available: [https://www.tutorialspoint.com/http/http\\_overview.htm](https://www.tutorialspoint.com/http/http_overview.htm). [Accessed 30 October 2017].
- [54] MDN Web docs, "Express/Node Introduction," 12 August 2017. [Online]. Available: [https://developer.mozilla.org/en-US/docs/Learn/Server-side/Express\\_Nodejs/Introduction](https://developer.mozilla.org/en-US/docs/Learn/Server-side/Express_Nodejs/Introduction). [Accessed 30 October 2017].
- [55] Angular.js, "What is AngularJS?," [Online]. Available: <https://docs.angularjs.org/guide/introduction>. [Accessed 30 October 2017].
- [56] Wikipedia, "Web application," [Online]. Available: [https://en.wikipedia.org/wiki/Web\\_application](https://en.wikipedia.org/wiki/Web_application). [Accessed 30 October 2017].
- [57] Smashing Magazine, "Facing the Challenge: Building a Responsive Web Application," 12 June 2013. [Online]. Available: <https://www.smashingmagazine.com/2013/06/building-a-responsive-web-application/>. [Accessed 30 October 2017].
- [58] TechTarget, "Native App," [Online]. Available: <http://searchsoftwarequality.techtarget.com/definition/native-application-native-app>. [Accessed 30 October 2017].
- [59] Techopedia, "Native Mobile App," [Online]. Available: <https://www.techopedia.com/definition/27568/native-mobile-app>. [Accessed 30 October 2017].

- [60] LifeWire, "The Pros and Cons of Native Apps and Mobile Web Apps," 19 April 2017. [Online]. Available: <https://www.lifewire.com/pros-and-cons-of-native-apps-and-mobile-web-apps-2373173>. [Accessed 25 October 2017].
- [61] Wikipedia, "Amazon Echo," [Online]. Available: [https://en.wikipedia.org/wiki/Amazon\\_Echo](https://en.wikipedia.org/wiki/Amazon_Echo). [Accessed 25 October 2017].
- [62] Amazon Alexa, "Design Process," [Online]. Available: <https://developer.amazon.com/designing-for-voice/design-process/>. [Accessed 30 October 2017].
- [63] ProgrammableWeb, "How to Get Started With Amazon's Alex Skills Set," 2 August 2016. [Online]. Available: <https://www.programmableweb.com/news/how-to-get-started-amazon%E2%80%99s-alexa-skills-kit/how-to/2016/08/02>. [Accessed 29 October 2017].
- [64] Texas Instruments, "Code Composer Studio - Integrated Development Environment," [Online]. Available: <http://www.ti.com/tool/CCSTUDIO>. [Accessed 15 November 2017].
- [65] Wikipedia, "Arduino," [Online]. Available: [https://en.wikipedia.org/wiki/Arduino#Software\\_development](https://en.wikipedia.org/wiki/Arduino#Software_development). [Accessed 15 November 2017].
- [66] Arduino, "Arduino Software (IDE)," [Online]. Available: <https://www.arduino.cc/en/Guide/Environment#toc1>. [Accessed 15 November 2017].
- [67] Arduino, "Getting Started with the Arduino Web Editor," [Online]. Available: [https://create.arduino.cc/projecthub/Arduino\\_Genuino/getting-started-with-the-arduino-web-editor-4b3e4a](https://create.arduino.cc/projecthub/Arduino_Genuino/getting-started-with-the-arduino-web-editor-4b3e4a). [Accessed 16 November 2017].
- [68] Wikipedia, "Eclipse (Software)," [Online]. Available: [https://en.wikipedia.org/wiki/Eclipse\\_\(software\)](https://en.wikipedia.org/wiki/Eclipse_(software)). [Accessed 16 November 2017].
- [69] Arduino, "Eclipse plugin AVR-eclipse," [Online]. Available: <http://playground.arduino.cc/Code/Eclipse>. [Accessed 16 November 2017].
- [70] Wikipedia, "Microsoft Visual Studio," [Online]. Available: [https://en.wikipedia.org/wiki/Microsoft\\_Visual\\_Studio](https://en.wikipedia.org/wiki/Microsoft_Visual_Studio). [Accessed 16 November 2017].
- [71] Visual Micro, "Arduino IDE for Visual Studio and Atmel Studio," [Online]. Available: <http://www.visualmicro.com/>. [Accessed 16 November 2017].

- [72] Atmel Studio, "Atmel Studio 7," [Online]. Available: <http://www.atmel.com/Microsite/atmel-studio/default.aspx>. [Accessed 16 November 2017].
- [73] Allied Electronics, "White-Rodgers 90-T4F03," [Online]. Available: <https://www.alliedelec.com/white-rodgers-90-t40f3/70101872/>. [Accessed 25 October 2017].
- [74] Altronix, "TP2450," [Online]. Available: <https://www.altronix.com/products/TP2450>. [Accessed 25 October 2017].
- [75] ELK Products, "AC transformers ELK-TRG2440," [Online]. Available: <https://www.elkproducts.com/product-catalog/elk-trg2440-ac-transformer-24-vac-40-va-auto-resetting-grounding-prong-and-terminal>. [Accessed 25 October 2017].
- [76] ON Semiconductor, "Axial Lead Standard Recovery Rectifiers," October 2012. [Online]. Available: <http://www.onsemi.com/pub/Collateral/1N4001-D.PDF>. [Accessed 25 October 2017].
- [77] ON Semiconductor, "SWITCHMODE Power Rectifiers," May 2013. [Online]. Available: <http://www.mouser.com/ds/2/308/MUR120-D-79667.pdf>. [Accessed 25 October 2017].
- [78] Taiwan Semiconductor, "Silicon Rectifier," [Online]. Available: [http://www.mouser.com/ds/2/395/1N5391%20SERIES\\_D14-523501.pdf](http://www.mouser.com/ds/2/395/1N5391%20SERIES_D14-523501.pdf). [Accessed 26 October 2017].
- [79] Shindengen, "Bridge Diode," [Online]. Available: <http://www.mouser.com/ds/2/366/J534S1VB-1203037.pdf>. [Accessed 26 October 2017].
- [80] Diodes Incorporated, "2A Surface Mount Glass Passivated Bridge Rectifier," March 2017. [Online]. Available: <http://www.mouser.com/ds/2/115/ABS210-1112801.pdf>. [Accessed 26 October 2017].
- [81] Comchip SMD Diode Specialist, "SMD Glass Passivated Bridge Rectifiers," [Online]. Available: <http://www.mouser.com/ds/2/80/DF2005S-G%20Thru340567.%20DF210S-G%20RevF-535444.pdf>. [Accessed 26 October 2017].
- [82] Shindengen, "Bridge Diode," [Online]. Available: <http://www.mouser.com/ds/2/366/J534D10XB-1203178.pdf>. [Accessed 26 October 2017].

- [83] Texas Instruments, "UCC28630, UCC28631, UCC28632 and UCC28633, High-Power Flyback Controller with Primary-Side Regulation and Peak-Power Mode," March 2017. [Online]. Available: <http://www.ti.com/lit/ds/symlink/ucc28630.pdf>. [Accessed 7 November 2017].
- [84] Texas Instruments, "UCCx813-x Low-Power Economy BiCMOS Current-Mode PWM," August 2016. [Online]. Available: <http://www.ti.com/lit/ds/symlink/ucc2813-2.pdf>. [Accessed 7 November 2017].
- [85] Texas Instruments, "UCC28740 Constant-Voltage Constant-Current Flyback Controller using Optocoupled Feedback," July 2017. [Online]. Available: <http://www.ti.com/lit/ds/symlink/ucc28740.pdf>. [Accessed 7 November 2017].
- [86] Tenergy, "Lithium Ion," [Online]. Available: <http://www.tenergy.com/Site/Li-Ion-Category>. [Accessed 14 November 2017].
- [87] All-battery.com, "Battery Packs (3.7V-37V)," [Online]. Available: <http://www.all-battery.com/li-ionpacksandmodules.aspx>. [Accessed 14 November 2017].
- [88] Aleko, "Solar Panel - Monocrystalline - 12V - 30W," [Online]. Available: <https://www.alekoproducts.com/ALEKO-Solar-Panel-30-Watt-12-Volt-Monocrystalline-p/sp30w12v-ap.htm>. [Accessed 15 November 2017].
- [89] Renogy, "Renogy 30 Watt 12 volt Monocrystalline Solar Panel," [Online]. Available: [https://www.renogy.com/renogy-30-watt-12-volt-monocrystalline-solar-panel/#tab\\_prd-specs](https://www.renogy.com/renogy-30-watt-12-volt-monocrystalline-solar-panel/#tab_prd-specs). [Accessed 15 November 2017].
- [90] SolarTech power Inc., "M-Series 30W PV Module SPM030P-A," [Online]. Available: <https://www.solar-electric.com/lib/wind-sun/SPM030P-A.pdf>. [Accessed 15 November 2017].
- [91] Dasol, "Dasol DS-A18-30, 30W 12VDC Solar Panel," [Online]. Available: <https://www.gogreensolar.com/products/dasol-ds-a18-30-30w-12vdc-solar-panel>. [Accessed 15 November 2017].
- [92] Linear Technology, "LT1083/LT1084/LT1085 Fixed," 1994. [Online]. Available: <https://www.jameco.com/Jameco/Products/ProdDS/1729725.pdf>. [Accessed 27 October 2017].
- [93] ON Semiconductor, "LM78XX / LM78XXA," 2006. [Online]. Available: <https://www.fairchildsemi.com/datasheets/LM/LM7805.pdf>. [Accessed 26 October 2017].

- [94] National Semiconductor, "LM1084," June 2005. [Online]. Available: <https://cdn.solarbotics.com/products/datasheets/lm1084.pdf>. [Accessed 26 October 2017].
- [95] ST Microelectronics, "L7800 Series," November 2004. [Online]. Available: <https://cdn.sparkfun.com/datasheets/Components/General/TO-220.pdf>. [Accessed 26 October 2017].
- [96] STMicroelectronics, "LD1117A," 2013. [Online]. Available: <http://www.st.com/content/ccc/resource/technical/document/datasheet/a5/c3/3f/c9/2b/15/40/49/CD00002116.pdf/files/CD00002116.pdf/jcr:content/translations/en.CD00002116.pdf>. [Accessed 7 November 2017].
- [97] RobotShop, "12V Low Noise DC Motor 146RPM w/Encoder," [Online]. Available: <http://www.robotshop.com/en/12v-low-noise-dc-motor-146rpm-w-encoder.html>. [Accessed 14 November 2017].
- [98] RobotShop, "12V DC Motor 251RPM w/Encoder," [Online]. Available: <http://www.robotshop.com/en/12v-dc-motor-251rpm-encoder.html>. [Accessed 14 November 2017].
- [99] RobotShop, "Lynxmotion 12V 90 rpm 99.11oz-in 1:26.9 Brushed DC Gear Motor w/Encoder," [Online]. Available: <http://www.robotshop.com/en/lynxmotion-12v-90-rpm-9911oz-in-1269-brushed-dc-gear-motor-w--encoder.html>. [Accessed 14 November 2017].
- [100] Texas Instruments, "DRV8829 5-A 45-V Single H-Bridge Motor Driver," September 2015. [Online]. Available: <http://www.ti.com/lit/ds/slvs74e/slvs74e.pdf>. [Accessed 14 November 2017].
- [101] Infineon Technologies, "5-A H-Bridge for DC-Motor Applications," [Online]. Available: [http://www.farnell.com/datasheets/1651367.pdf?\\_ga=2.28490876.1911613565.1509633343-549294474.1501855502](http://www.farnell.com/datasheets/1651367.pdf?_ga=2.28490876.1911613565.1509633343-549294474.1501855502). [Accessed 14 November 2017].
- [102] STMicroelectronics, "L6201," [Online]. Available: <http://www.mouser.com/ds/2/389/l6201-954873.pdf>. [Accessed 14 November 2017].
- [103] Arduino, "Arduino Nano," [Online]. Available: <https://store.arduino.cc/usa/arduino-nano>. [Accessed 7 November 2017].
- [104] Texas Instruments, "MSP430 LaunchPad Value Line Development Kit," [Online]. Available: <http://www.ti.com/tool/MSP-EXP430G2#Technical Documents>. [Accessed 7 November 2017].

- [105] Adafruit, "Introducing Trinket," [Online]. Available: <https://learn.adafruit.com/introducing-trinket/faq>. [Accessed 7 November 2017].
- [106] Everlight, "Technical Data Sheet 5mm Infrared LED, T-1 3/4," 20 July 2005. [Online]. Available: [https://cdn-shop.adafruit.com/datasheets/IR333\\_A\\_datasheet.pdf](https://cdn-shop.adafruit.com/datasheets/IR333_A_datasheet.pdf). [Accessed 7 November 2017].
- [107] China Young Sun LED Technology Co., LTD., "Model No.: YSL-R531FR1C-F1," [Online]. Available: <https://cdn.sparkfun.com/datasheets/Components/LED/YSL-R531FR1C-F1.pdf>. [Accessed 7 November 2017].
- [108] Vishay Semiconductors, "IR Receiver Modules for Remote Control Systems," 12 March 2012. [Online]. Available: <https://cdn-shop.adafruit.com/datasheets/tsop382.pdf>. [Accessed 7 November 2017].
- [109] Sharp, "IS471F," [Online]. Available: <https://media.digikey.com/pdf/Data%20Sheets/Sharp%20PDFs/IS471F.pdf>. [Accessed 7 November 2017].
- [110] Parallax, "PIR Sensor (#555-28027)," 26 April 2011. [Online]. Available: <https://www.jameco.com/Jameco/Products/ProdDS/2082927.pdf>. [Accessed 8 November 2017].
- [111] RobotShop, "Adjustable PIR Motion Sensor," [Online]. Available: [http://www.robotshop.com/en/adjustable-pir-motion-sensor.html?gclid=CjwKCAiAoqXQBRA8EiwAlIOWsrt-ulqykIFp\\_loClalKEZ8ZxOju9MXRhdbbBzXph9ayjjL5JaQvhoCA\\_4QAvD\\_BwE](http://www.robotshop.com/en/adjustable-pir-motion-sensor.html?gclid=CjwKCAiAoqXQBRA8EiwAlIOWsrt-ulqykIFp_loClalKEZ8ZxOju9MXRhdbbBzXph9ayjjL5JaQvhoCA_4QAvD_BwE). [Accessed 8 November 2017].
- [112] Sparkfun, "OpenPIR Hookup Guide," [Online]. Available: [https://learn.sparkfun.com/tutorials/openpir-hookup-guide?\\_ga=2.228655132.1425294023.1510585609-679372022.1504386743](https://learn.sparkfun.com/tutorials/openpir-hookup-guide?_ga=2.228655132.1425294023.1510585609-679372022.1504386743). [Accessed 8 November 2017].
- [113] FresnelFactory.com, "PIR motion detector(Infrared)," [Online]. Available: <http://www.fresnelfactory.com/sensor-pir/>. [Accessed 14 November 2017].
- [114] Microchip, "ATSAMW25," [Online]. Available: <http://www.microchip.com/wwwproducts/en/ATSAMW25>. [Accessed 14 November 2017].
- [115] STMicroelectronics, "SPWF04SA," [Online]. Available: [http://www.st.com/content/st\\_com/en/products/wireless-connectivity/wi-fi/spwf04sa.html](http://www.st.com/content/st_com/en/products/wireless-connectivity/wi-fi/spwf04sa.html). [Accessed 14 November 2017].

- [116] Elecrow, "ESP-12S User Manual," July 2016. [Online]. Available: [https://www.elecrow.com/download/ESP-12S\\_User\\_Manual.pdf](https://www.elecrow.com/download/ESP-12S_User_Manual.pdf). [Accessed 14 November 2017].
- [117] w3schools.com, "HTML Color Picker," [Online]. Available: [https://www.w3schools.com/colors/colors\\_picker.asp](https://www.w3schools.com/colors/colors_picker.asp). [Accessed 24 October 2017].
- [118] Adafruit, "RGB LED Weatherproof flexi-strip 60 LED/m," [Online]. Available: <https://www.adafruit.com/product/346>. [Accessed 14 November 2017].
- [119] Adafruit, "Adafruit NeoPixel Digital RGB LED Strip - White 60 LED - WHITE," [Online]. Available: <https://www.adafruit.com/product/1138>. [Accessed 14 November 2017].
- [120] Adafruit, "Adafruit DotStar Digital LED Strip - Black 60 LED - Per Meter - BLACK," [Online]. Available: <https://www.adafruit.com/product/2239>. [Accessed 14 November 2017].
- [121] Joann, "Roc-Lon Blackout Lining Fabric-Budget Fabric 54"-BlackoutWhite/White," [Online]. Available: <http://www.joann.com/roc-lon-budget-blackout-white-white/2117232.html>. [Accessed 15 November 2017].
- [122] Tutorial Republic, "Bootstrap Introduction," [Online]. Available: <https://www.tutorialrepublic.com/twitter-bootstrap-tutorial/bootstrap-introduction.php>. [Accessed 28 October 2017].
- [123] FireBase, "Documentation," 31 October 2017. [Online]. Available: <https://firebase.google.com/docs/functions/http-events>. [Accessed 31 October 2017].
- [124] IEEE Standards Association, "About Us," [Online]. Available: <http://standards.ieee.org/about/ieeesa.html>. [Accessed 25 October 2017].
- [125] Wikipedia, "IEEE 802.11," [Online]. Available: [https://en.wikipedia.org/wiki/IEEE\\_802.11#Protocol](https://en.wikipedia.org/wiki/IEEE_802.11#Protocol). [Accessed 25 October 2017].
- [126] IEEE Standards Association, "1625-2008 - IEEE Standards for Rechargeable Batteries for Multi-cell Mobile Computing Devices," 2009. [Online]. Available: <https://standards.ieee.org/findstds/standard/1625-2008.html>. [Accessed 25 October 2017].
- [127] IEEE Standards Association, "1754-1994 - IEEE Standard for a 32-bit Microprocessor Architecture," [Online]. Available: <https://standards.ieee.org/findstds/standard/1754-1994.html>. [Accessed 25 October 2017].

- [128] Arduino, "Arduino Style Guide," [Online]. Available: <https://www.arduino.cc/en/Reference/StyleGuide>. [Accessed 16 November 2017].
- [129] W. Hart, "Your First Prototype: Fabrication Specifications and Gerber Files," Prototype 2 Production, 27 March 2015. [Online]. Available: <http://www.proto2prod.com/proto2prod/2015/3/18/your-first-prototype-fab-specs-and-gerber-files-13>. [Accessed 14 November 2017].
- [130] Expresss PCB, "ExpressPCB," [Online]. Available: <https://www.expresspcb.com/>. [Accessed 15 November 2017].
- [131] Advanced Circuits, "Engineering Student Program," [Online]. Available: <http://www.4pcb.com/pcb-student-discount.html>. [Accessed 15 November 2017].
- [132] Elecrow, "Elecrow," [Online]. Available: <https://www.elecrow.com/>. [Accessed 15 November 2017].
- [133] OSH Park, "OSH Park," [Online]. Available: <https://oshpark.com/>. [Accessed 15 November 2017].
- [134] E. Jordan and K. G. Balmain, *Electromagnetic Waves and Radiating Systems* (2nd ed.), Prentice-Hall, 1968.
- [135] "Wikipedia," [Online]. Available: [https://en.wikipedia.org/wiki/Rectifier#Half-wave\\_rectification\\_.28M1U.29](https://en.wikipedia.org/wiki/Rectifier#Half-wave_rectification_.28M1U.29). [Accessed 24 October 2017].
- [136] B. Mitchell, "Gallery of Home Network Diagrams," [Online]. Available: <https://www.lifewire.com/home-network-diagrams-4064053>. [Accessed 2 November 2017].
- [137] K. Ren, "Ten Important Differences Between Bluetooth BREDR and Bluetooth Smart," [Online]. Available: <https://blog.bluetooth.com/ten-important-differences-between-bluetooth-bredr-and-bluetooth-smart>. [Accessed 2 November 2017].
- [138] ICPDAS, "What is ZigBee?," [Online]. Available: [http://www.icpdas.com/root/product/solutions/industrial\\_wireless\\_communication/wireless\\_solutions/zigbee\\_introduction.html](http://www.icpdas.com/root/product/solutions/industrial_wireless_communication/wireless_solutions/zigbee_introduction.html). [Accessed 2 November 2017].
- [139] Arduino, "Software," [Online]. Available: <https://www.arduino.cc/en/Main/Software>. [Accessed 15 November 2017].