



# AUTOMATED PET FEEDER

University of Central Florida – Group 31

Paola A. Buitrago – Cp.E  
Malcolm A. Morgan – Cp.E  
Hector L. Rodriguez – E.E

# Contents

1	Executive Summary.....	1
2	Project Description .....	2
2.1	Requirements and Specifications .....	2
3	Research and Part Selection.....	8
3.1	Similar Products .....	8
3.2	Market .....	10
3.3	Power .....	11
3.3.1	Power Introduction .....	11
3.3.2	Printed Circuit Board .....	13
3.3.3	Switch.....	15
3.3.4	Power Indicator .....	17
3.3.5	Transformer .....	18
3.3.6	Diodes .....	19
3.3.7	Capacitors .....	24
3.3.8	Voltage Regulators .....	27
3.4	Doors.....	30
3.5	Motors .....	32
3.5.1	Brushed Motors Vs Brushless Motor.....	33
3.5.2	DC Motor.....	34
3.5.3	Servomotor Vs. Stepper Motor .....	35
3.6	Motor Shields.....	36
3.7	Water Pumps .....	38
3.8	Water Reservoir Sensors .....	40
3.9	Food Reservoir Monitoring .....	42
3.10	Food and Water Bowls.....	44
3.11	Radio Frequency Identification .....	45
3.11.1	RFID Tags.....	45
3.11.2	RFID Reader.....	48
3.12	Camera.....	52
3.13	Scale .....	55
3.13.1	Load Cell.....	55
3.13.2	Analog to Digital Converter .....	58
3.13.3	Proximity Sensors.....	59

## Automated Pet Feeder

3.14	Parts Selection .....	62
3.15	Software.....	64
3.15.1	Operating Systems .....	64
3.15.2	Raspbian.....	64
3.15.3	Pidora.....	64
3.15.4	RISC OS Pi .....	65
3.16	Programming Languages.....	65
3.16.1	Python.....	65
3.16.2	C++ and Java.....	65
3.17	Databases.....	68
3.17.1	PostgreSQL.....	68
3.17.2	MySQL.....	68
3.17.3	Firebird.....	68
3.17.4	MariaDB .....	69
4	Design Constraints and Standards .....	69
4.1	Senior Design Constraints .....	69
4.1.1	Parts List Budget.....	69
4.1.2	Time Constraint.....	70
4.1.3	Final Product Price Constraint .....	70
4.2	Standards .....	71
4.2.1	IEC Power Standards .....	71
4.2.2	Filament Standards .....	73
4.2.3	Water Quality Standards .....	75
4.2.4	Rain RFID Standards .....	75
5	Design .....	77
5.1	Schematics .....	77
5.1.1	Schematic Design – Power Supply.....	77
5.2	Interface.....	78
5.2.1	Hardware User interface .....	78
5.2.2	Software User Interface .....	79
5.3	Dispensing Method .....	83
5.4	Scale Design .....	85
5.5	Enclosure Design .....	87
6	System Testing.....	88
6.1	Overall Integration .....	88

## Automated Pet Feeder

6.2	Power Supply Testing.....	90
6.3	Microcontroller and Motor Testing.....	92
7	Administration .....	94
7.1	Milestone Discussion .....	94
7.1.1	Budget Analysis .....	95
8	Conclusion.....	96
9	Appendix.....	97
9.1	References .....	97
9.2	Table of Figures.....	104
9.3	Copyright.....	106

# 1 Executive Summary

According to Statista, the number of dogs living in households in the United States has reached a high of 89.7 million as of 2017 [1]. Considering that Census Bureau has estimated the United States population to be 325.8 million as of writing, this culminates in roughly 27.5% of the population owning a dog as a pet [2]. Undoubtedly, dogs are an important aspect of many households in the United States, though many individuals find themselves in the daily routine of feeding their dogs, and for many, complications arise when one's occupation separates one from his or her dog for long periods of time each day, or when one owns more than one dog, which requires a different feeding routine than the norm. Two of the three members in our group own at least one dog, with one member owning two dogs, and the other member planning on adopting a dog once shortly after graduation. Thus, several of the solutions to dog ownership that this project addresses are as a direct result of problems encountered by members of our group, and these solutions could certainly be employed in the lives of many other dog owners.

As its name implies, the objectives and goals of the Automated Pet Feeder include a collection of requirements that are meant to ease the burden of pet ownership. One objective is that the Automated Pet Feeder must continually monitor the weight of the food and water supply of both its dispensers, while also holding a minimum quantity of food and water capable of feeding a large dog for an extended period of time, particularly several days. The Automated Pet Feeder must also be able to differentiate between various dogs, and only dispense food to a dog specified by the owner, while simultaneously preventing unauthorized dogs, and other unauthorized pets from obtaining food from the food dispenser. Support for additional functionality of the Automated Pet Feeder will be accomplished using a dedicated IP address designated to a file server, and lastly, the Automated Pet Feeder must employ inexpensive materials and a relatively simple manufacturing process, which must allow it to be priced less than competitive products.

Functionality of the Automated Pet Feeder are derived from the several objectives listed above. The Automated Pet Feeder will dispense food and water in portions of weight and volume, respectively, that will have been specified by the pet's owner, and these portions must be able to be specified from an application on the pet owner's mobile device. Data and general information regarding the dog's eating patterns will be sent to the pet owner's mobile device, also including the ability to stream live footage of the apparatus's environment from a camera located on the apparatus. The ability to differentiate between an authorized pet and unauthorized pets will be accomplished using collar recognition, which is one of the primary features that sets apart the Automated Pet Feeder from its competition. The primary competitor to the Automated Pet Feeder is the Gosh EasyFeed, which is a similar project being funded and advertised on *Kickstarter*[3].

## 2 Project Description

### 2.1 Requirements and Specifications

- The Automated Pet Feeder will store approximately two days' worth of food along with filtered water system for a fresh supply of water.
- Collar Recognition using RFID technology will be used so only the pet with the correct tag can access the food.
- Using an app, user can set a profile that will determine the correct amount of food dispensing according to the pet's needs.
- Using a weight scale sensor, food will be dispensed until the cutoff point determined by the app.
- In case of a power outage, a backup battery will be used that will last up to at least a day.
- Using a 3D printer, enclosure will be created to fit metal bowls and drive cost of materials down.
- Mobile app will track how much food is dispensed alerting the user that it will be time to order new food ahead of time.
- Information on how much food will be stored in a database to build analytical history for the user.

### Software Block Diagram

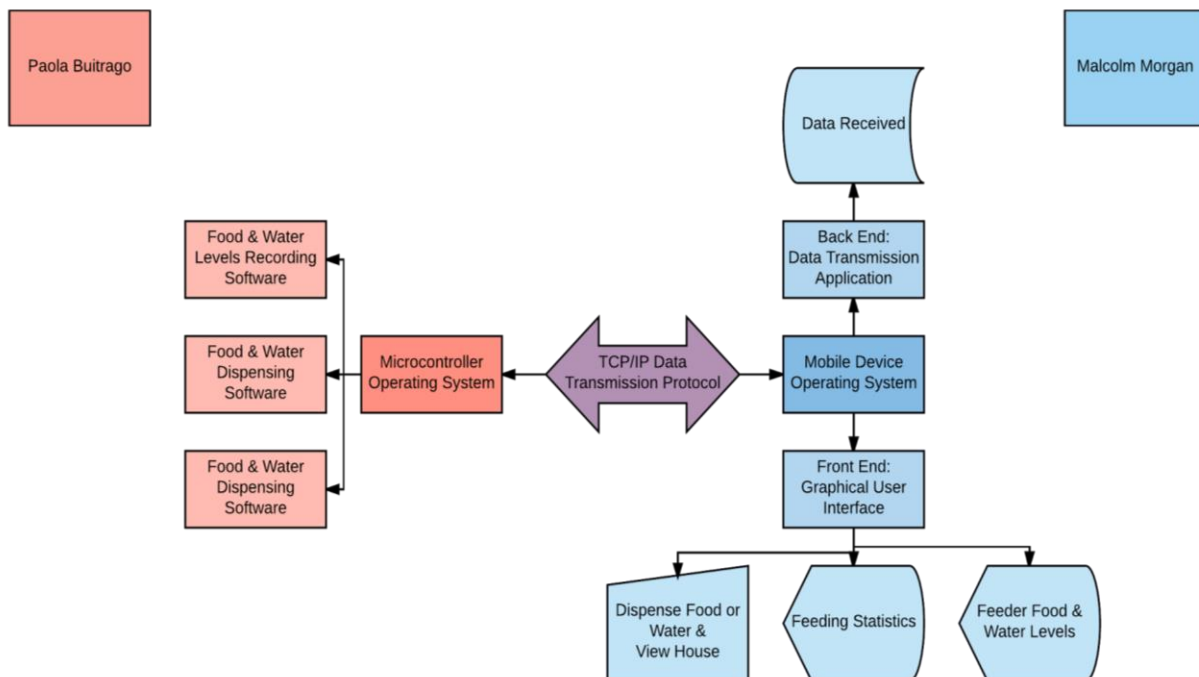

## Hardware Block Diagram

Hector Rodriguez

Malcolm A. Morgan

Paola A. Buitrago

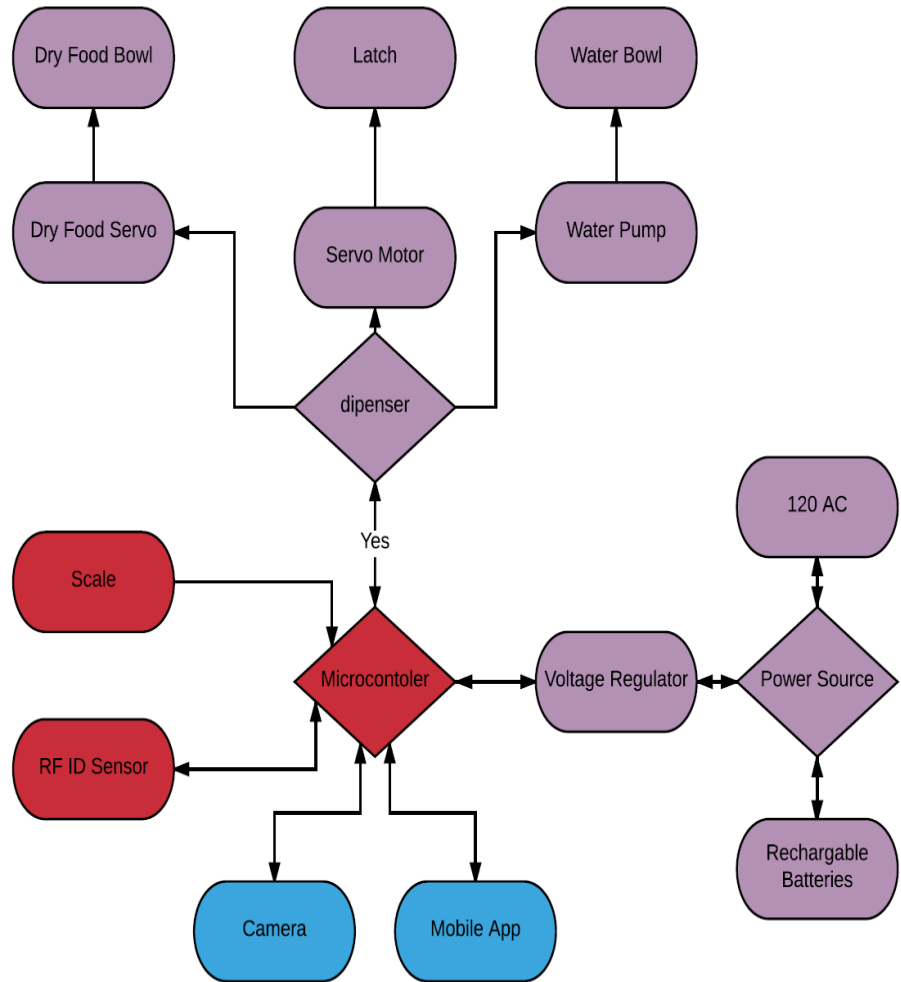





**Table 1 - Budget and Financing**

Item	Quantity	Price	Total Cost
3D Printer	1	N/A (owned)	N/A (owned)
Water Pump	1	\$16	\$16
PCB	1 (one pack = 30)	\$13	\$13
Controller	1	\$35	\$35
Weight Scale	1	\$6 - \$15	\$15 (worst case)
Rubber Paddle Rotor	1	\$35	\$35
Metal Bowl	1	\$7 - \$10	\$10 (worst case)
Power Supply	1	\$25	\$25
LED Lights	1 (pack)	\$5	\$5
Total:			\$154

**Table 2 - Fall Project Milestones**

Deliverable	Customer	Due Date/Milestone	Length of Time to Complete?	Steps to Completion
10 Page Paper	SD Advisors	9-22-2017	2 - Weeks	Divide and Conquer
Material List	SD Advisors	9-29-2017	1 - Week	Research What is Needed
Prototype Draft	Team	9-29-2017	1 - Week	Each Member Design a Draft
Budget Draft	Team/SD Advisors	9-22-2017	2 - Weeks	Compare Similar Items
Schematic	Team/SD Advisors	10-6-2017	2 - Weeks	Solidworks
App Options	Team/SD Advisors	11-17-2017	6 - Weeks	Research SW Options
Buy Materials	Team/SD Advisors	10-13-2017	1 - Week	Order Parts
Finish 90 Page Report	Advisors	12-01-2017	12 - Weeks	Divide and Conquer

**Table 3 - Spring Project Milestones**

Deliverable	Customer	Due Date/Milestone	Length of Time to Complete?	Steps to Completion
Finalize Parts for Prototype	Team	01-19-2018	2 - Weeks	Make Sure Parts are Compatible
Assembled Hardware	Team	02-02-2018	2 - Week	Gather Tools for Assembly
Software for Microcontroller	Team	02-02-2018	1 - Week	Research Freeware
Software for Mobile Device	Team	02-23-2018	2 - Weeks	Research Freeware
Integrate SW & HW	Team	03-09-2018	2 - Week	Team Integration Sessions
Finalize External Enclosure	Team	03-16-2018	1 - Week	Tweak Schematic
Print Enclosure & Assemble	Team	03-30-2018	2 - Weeks	Make Final Adjustment
Have Working Project	SD Advisors	04-06-2018	1 - Week	Make it Look Pretty

## 3 Research and Part Selection

### 3.1 Similar Products



**Figure 1: FunPaw Automated Pet Feeder. Bottom left: Petnet SmartFeeder. Bottom right: Petmate Portion Right Programmable Pet**

There is plenty of competition when contemplating purchasing an automated pet feeder. Some are geared for specific types of animals. Some are meant to feed multiple pets while some are meant for only one animal. As a product that would be competing with other products on the market, our Automated Pet Feeder needs to stand out when compared. The products that are most comparable are the Petnet SmartFeeder, Petmate Portion Right Programmable Pet Feeder, and the FunPaw automated pet feeder. These pet feeders may be similar to our automated pet feeder but in multiple ways our pet feeder will meet and exceed most capabilities.

The Petmate Portion Right Programmable Pet Feeder is a similar when comparing to how big the reservoir would be. The Petmate Portion Right Programmable Pet Feeder comes in two options, a 5lb or 10lb capacity limits. Our pet feeder will hold a comparable amount of food to avoid constant filling of the reservoir, which could become a nuisance for the owner. The reservoir has a screw-based system that is used for sealing the pet's food. This detail is great to ensure that the pet's food is kept as fresh as possible. Due to the shape of our pet feeder, we will be forced to use more of a latch style design. The Petmate Portion Right Programmable Pet Feeder is also a great example of how most pet feeders in the market operate by dispensing a set amount of food based on a timer. This particular product allows the consumer to set a given amount of food to be dispensed up to three times per day. This product does not have the capability of knowing whether or not your pet has eaten the food that has been dispensed. The product also fails to realize if there is already food in the bowl. This could lead to malnutrition and even food dispensing failure that could occur from the food backing up into the system from lack of sensors.

The Petnet SmartFeeder could be considered the most comparable to our design of the Automated Pet Feeder. Petnet's automated feeder allows the customer to connect to an application and monitor their pets feeding habits. This feeder holds 5 to 7lbs of food and features a square style reservoir. It is controlled solely by an application that connects to the feeder wirelessly. The user can set specific times to feed. The application assists in this by allowing the user to input their pet's breed, size, weight and more to recommend types of food and even portions to ensure proper nutrition. If the owner would like to see images of their pet the owner must wait for the designated feeding time and a camera provided by a third party, will take images of your pet during the first five minutes of the feeding period. Our design eliminates the need for a third part camera that forces the owner to spend more money on extra parts in order to see their pet because with our design the camera will be built into the feeder itself. Once again, this feeder monitors the pets feeding based on the amount of food that has been dispensed. It does not know whether or not your pet is actually eating the food dispensed let alone the time your pet is eating. Petnet, however has released a SmartBowl that is based on weight of the food dispensed and can then informs the customer how much calories your pet has consumed. Like the name implies the "SmartBowl" is only a bowl. This does not come with a food reservoir. Our pet feeder takes on the capabilities of the SmartFeeder, SmartBowl and the Nest camera and puts it all in one package with no third-party involvement. Our feeder will not only monitor the amount dispensed but also it will allow for precise eating habit information to be produced by the scale that will be used below the bowl. The user will be able to know when and how much your pet is eating. The camera will be accessible 24/7 to the user with the use of our app.

FunPaw's automated pet feeder is another feeder that can be compared to our Automated Pet Feeder. Once again FunPaw's automated pet feeder allows the user program, via an app, the amount of food and when the food will be dispensed. Unlike the PetNet Smart Feeder, FunPaw's designed a feeder with a built in 120-degree wide angel camera. One notable difference between our feeder and FunPaw's automated pet feeder is that our feeder will be for any size pet where as FunPaw's is geared more for small to medium sized pets. It can only dispense between .4 to 3.5 ounces at a time to ensure for careful

measurements. Like in all the feeders that have been mentioned, FunPaw’s Automated Pet Feeder does not know when and exactly how much your pet has actually eaten. It only knows how much has been dispensed. Like mentioned previously, our automated pet feeder will be able to inform the user exactly how much food has been dispensed, when his or her pet is eating and precisely how much the pet has eaten.

Our automated pet feeder will utilize much of the features discussed in this section in an all in one approach. The key features that will separate our automated pet feeder from the completion will be multiple attributes. First, the bowl will have a scale underneath to allow the system to truly and precisely monitor your pet's feeding habits. Second, the automated pet feeder will consist of a built-in camera similar to that found in the FunPaw’s Automated Pet Feeder design. This eliminates extra costs to the consumer by taking out the need of a third-party vendor to supply a camera and a monthly subscription in order to monitor your pet. The feeder will consist of a reservoir that will be sufficient enough to hold three to five days’ worth of food for your pet. Like seen in all the competitors’ examples given, our Automated Pet Feeder will also use batteries as a backup battery source in case the user's household loses power and are not home.

### 3.2 Market

Pets are companion animals that an individual will keep for his or her benefit, and possibly also the benefit for the animal, and while more prevalent in some countries than others, it is no doubt that culture in the United States has highly favored some species over others. Two of the most popular species of pets in the United States include dogs and cats, and while the Automated Pet Feeder is purposely not marketed towards one specific species, the majority of the customers considering the purchase of a pet feeder will certainly be doing so as he or she owns a dog or a cat. Though to entirely understand the market for such a device, one must be aware of several key statistics which help to convey the notion.

Pet	Number	Pet	Number
Bird	7.9	Bird	6.1
Cat	47.1	Cat	42.9
Dog	60.2	Dog	54.4
Freshwater fish	12.5	Horse	2.5
Horse	2.6	Freshwater fish	12.3
Reptile	4.7	Saltwater fish	1.3
Saltwater fish	2.5	Reptile	4.9
Small animal	6.7	Small animal	5.4

**Figure 2: Pet Populations in the USA**

One prominent nonprofit organization that has surprisingly conducted a thorough and consistent set of research on pet ownership in the United States is the Insurance Information Institute (I.I.I.). I.I.I.'s mission is to provide a wide variety of research and information to the public pertaining not just to insurance, but many more topics. I.I.I. has been fulfilling this objective for over 60 years now, and one of the types of statistics that they have been tracking for several years now pertains to pet ownership. According to I.I.I., between the years of 2017 and 2018, approximately 60.2 million dogs were kept as pets within the United States, with the number of cats kept as pets trailing not too far behind at 38.9 million. While these numbers may seem great in terms of available market, it is even more important to note the change in the number of pets in the United States throughout the years. Therefore, in comparison to the statistics listed for the current years, between the years of 2015 and 2016 the number of dogs owned as pets by individuals living in the United States was 54.4 million, again with the number of cats trailing not too far behind at 42.9 million.

The rate at which the United States has experienced growth in the ownership of solely cats and dogs can be calculated using a rate equation. While the equation that states that distance is equal to the product of rate and time may not be initially suitable for this calculation, a simple replacement of the change in position variable with change in growth renders the former equation quite useful. Therefore, the equation used to determine the growth rate of pet ownership becomes, rate of pet growth is equal to the change in pet growth divided by time. Therefore, between the years of 2015 and 2016 to 2017 and 2018, the growth rate of dogs being owned as pets within the United States is 2.9 per, while the growth rate for cats is 2.1 per year. Looking at the figures from even earlier years, one can observe that growth has been consistent and steady. This growth is essential to the marketability of the Automated Pet Feeder, as this is designed to be a robust system that should not simply break over time, thus new customers are required to keep the availability of a market.

## 3.3 Power

### 3.3.1 Power Introduction

While the mechanical and electrical components of the Automated Pet Feeder are essential to its functionality, all work performed by the Automated Pet Feeder would not be possible without an adequate supply of energy delivered to it. This energy must be delivered to each component, at varying rates, and varying electric potentials. As different components require different voltages, purchasing a manufactured power supply was not an option, as the relatively inexpensive ones do not deliver the various required voltages, and power supplies that do offer many voltage rails are not economical with respect to the budget of a single Automated Pet Feeder. Therefore, an entirely custom power supply was the only solution to power the various components in the Automated Pet Feeder.

It is crucial that the Automated Pet Feeder has a reliable power source that will provide power to the entire system. The decision to use the power provided by the user's wall outlet was made for many reasons. The number one reason it was decided that it was best to use an alternating current or AC power source was due to the numerous features

that will be running even when not in use. Features such as the RFID tag reader that needs to scan every few microseconds, or the scale that is constantly sending data every few minutes, and other features that are continuously monitoring the system are why it was decided to use the AC power source of the user's wall outlet. Not only did we choose AC because of the constant power draw from the system, but also because it gave for more flexibility when designing the voltages that would be converted to supply DC power to the given components of the system. With the constant power draw that the system will be utilizing, it would become more of nonsense for the user to have to continually change batteries. Without a reliable power source such as that of the user's home provides, the automated feeder could possibly not power the system and fail to feed the pet as intended.

The need of a backup battery source is a crucial part of the automated pet feeders design requirements. The automated pet feeder needs to be a reliable system that the user can trust enough to leave the nutrition of its pet in the hands of an automated system. With the extra security measure of a battery-operated backup power source, the user can rest assure that his or her pet will be provided the proper nutrition each and every day as advertised. The backup battery source will consist of a configuration of batteries that will be sufficient enough to power the entire system for at least 48-72 hours. This should be sufficient time for the owner to heed the warnings provided by the application and take the measures to ensure the nutrition of the pet is taken care of.

**Table 4 - Power Supply Unit Parts**

Name	Function	Specification	Cost
Printed Circuit Board	Mount Components	Double Sided	\$6.96
Toggle Switch	Toggle Input Current	SPST	\$5.12
Neon Lamp	Power Indicator	Yellow, 120V	\$5.85
Transformer	Step Down Voltage	120V to 24V	\$12.83
Diodes	Rectify AC Signal	3A & 1000V	\$6.96
Capacitors	Stabilize Power	6800uF to 100nF	~\$10
Voltage Regulators	Regulate Voltage	5V, 9V, 12V, & 15V	\$13.99

The construction of the power supply of the Automated Pet Feeder involves numerous parts, though its end function is to provide a steady source of power with various electric potential rails of 5 volts, 9 volts, 12 volts, and 15 volts. The power supply rails with lower electric potential are designated for providing energy to the various microelectronics throughout the Automated Pet Feeder, which the power supply rails with higher electric potential are designated for providing power to the mechanical components that require a greater magnitude of power. The following sections of the Power section of this report



are the justifications for each part used in the fabrication of the power supply for the Automated Pet Feeder.

### 3.3.2 Printed Circuit Board

Considering that the power supply for the Automated Pet Feeder incorporates various integrated circuits, the need to mount these circuits in a compact, rigid configuration was inevitable. Several approaches were considered for a solution to mount the various components, though a printed circuit board was concluded to be the most efficient way to incorporate all of the predefined functionality and requirements needed to create the power supply. Various types of printed circuit boards exist, though a concise overview of the numerous options available will shed a great portion of light as to why the specified type of printed circuit board was chosen.

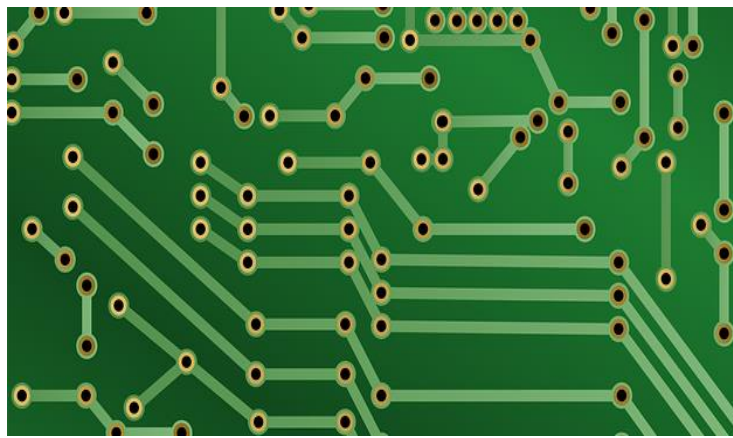

**Figure 3: Example of AC power supply**

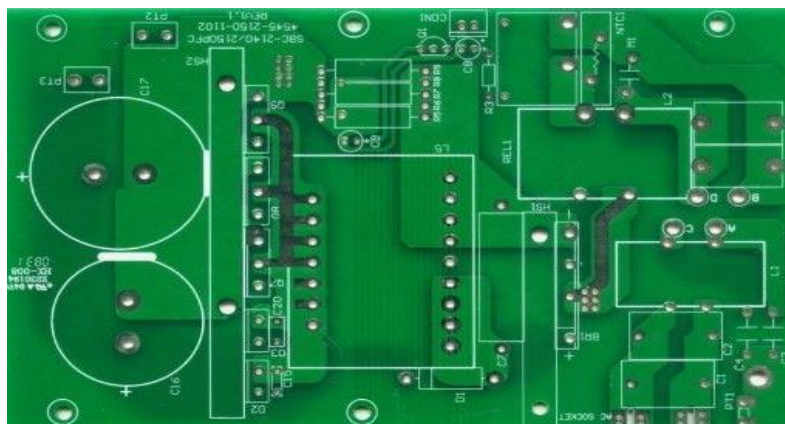

**Figure 4: Double Sided Printed Circuit Board**

One of the most simple configurations within the set of different types of printed circuit boards include the single-sided printed circuit board. These types of printed circuit boards have one layer of conductive substrate, typically copper, while the other side remains untraced. The primary advantage of single-sided printed circuit boards is their ability to be easily traced, therefore the functionality of the circuit is easy to understand from plain

sight [8]. While this may be an advantage for some users, this same advantage is a disadvantage when applied to complex circuits. Single sided printed circuit board can become very cluttered when many components are mounted onto them, as only 50 percent of their surface area is being utilized. The solution to this inefficiency that is intrinsic to single sided printed circuit boards is to utilize both sides of the surface, which then introduces the next type of printed circuit board that will be covered; the double sided printed circuit board. The double sided printed circuit board utilizes substrate on both sides of its surfaces to maximize the possible density of mounted components, with the addition of through-holes throughout the printed circuit board to allow for traces to be made between components on both sides.

Yet another variation of the printed circuit board is the multilayer printed circuit board. The multilayer printed circuit board allows for the end user to have the maximal degree of complexity compared to other types of printed circuit boards, as more layers can be added as the schematic of the design increases in complexity. Multilayer printed circuit boards also provide the advantage of reduced electromagnetic interferences between the traces, as the several layers act as shields from the electromagnetic fields being produced by traces within subsequent layers of the printed circuit board. Finally, the remaining two categories that tie these various types of printed circuit boards together is two remaining categories; rigid printed circuit boards and flexible printed circuit boards. As its name implies, a rigid printed circuit board is made from materials that do not provide a great deal of flexibility in its structure, while flexible printed circuit boards allow for the circuit to be fitted to various surroundings. The primary disadvantage of flexible printed circuit boards is also their advantage. Because they are flexible and not rigid, it reduces their usefulness for applications wherein a delicate piece of electrical hardware is not desired, and a more robust material is required to execute the objective at hand.



**Figure 5: Multilayer Printed Circuit Board**

All of the above advantages and disadvantages of the several types of printed circuit boards listed were carefully taken into consideration throughout the process of choosing the appropriated circuit board for the Automated Pet Feeder. As the schematic of the

power supply for the Automated Pet Feeder is relatively simple, a multilayer printed circuit board was deemed unnecessary. The decision to create significant spacing between the traces on the printed circuit board minimizes electromagnetic interferences becoming an issue in power delivery, thus simplifying the manufacturing process of the design. The need to mount relatively large, heat dissipating integrated circuit devices onto the printed circuit board also rendered flexible printed circuit boards not as a viable option for the power supply of the Automated Pet Feeder. Thus, the double sided, rigid printed circuit board was chosen as the type of printed circuit board to be used to implement the design.

### 3.3.3 Switch

While possibly the most overlooked, and unused function on many power supply units, most notably desktop computer power supply units, the switch that toggles power on and off that is located on many complex power supply units is a unit of the whole system that is imperative to the entirety of its functionality. Several types of switches exist, which all have the designated purpose of controlling power, though to understand which type of switch is most appropriate for the Automated Pet Feeder, a thorough understanding is required concerning the purpose and functionality of these various types of switches. The three types of switches that will be covered include “single-pole, single-throw”, “single-pole, double-throw”, and “double-pole, double-throw” [9].

One of the most common and simple switches, in terms of functionality, is none other than the single-pole, single-throw switch. The name of this switch is abbreviated as SPST, and it will be referred to as its abbreviation throughout the remaining portion of this report. SPST switches are possibly the most simple of the three variations of switches, as they require one output, and one input. SPST switches are ideal for applications wherein two leads are desired to be controlled in a binary format, that is, connected or unconnected. This type of switch can have many applications, though other circuits with more complex functionality tend to veer away from SPST switch.

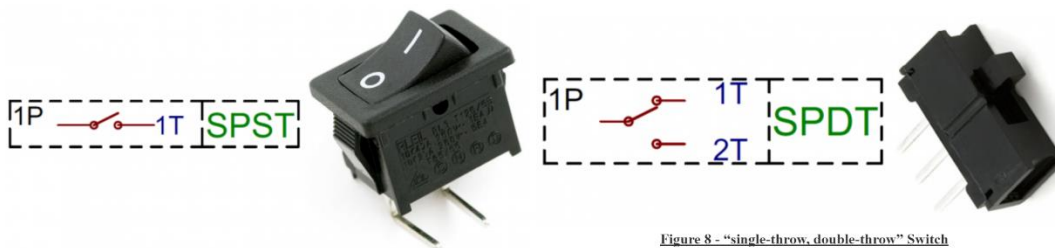

Figure 8 - “single-throw, double-throw” Switch

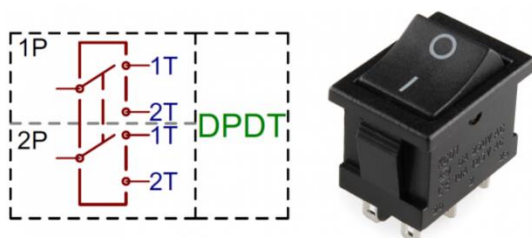

Figure 9 - “double-pole, double-throw” Switch

**Figure 6: Different Types of Switches**

Another less common type of switch is the “single-pole, double-throw” switch, which is abbreviated SPDT. SPDT switches differ from SPST switches as SPDT switches have three terminals. The primary concept surrounding SPDT switches is that they are best suited for applications wherein a single terminal is required to route to two different terminals, either one or the other, at different time. A common application of SPDT switches that is relatively easy to understand include 120V/240V switches seen on many older desktop power supplies. These switches route the input power source to either one or the other terminals on the transformer in the power supply unit, but cannot route the input source to both terminals. This routing mechanism incorporates the logic of the Exclusive OR, as the input must be always routed to one output, but the input is never routed to both outputs at the same time.

The final type of switch whose mechanism will be elaborated on is that of the “double-pull, double-throw” switch, which is abbreviated DPDT. DPDT switches are essentially a combination of two SPST switches, as DPDT switches have two inputs, which are routed to 4 outputs. These are the least common of the three types of switches listed, as such, their functionality and implementations are limited. One additional important aspect to note pertaining to switches is that all of the various types of switches mentioned above come in either momentary or none momentary (stationary) configurations. Momentary switches require a significant, constant force to keep the switch in the desired position, whereas none momentary retain the position they were assigned to without the need for an external force to keep them in place. Both types of configurations are widely used, though for the purpose of the Automated Pet Feeder, the none momentary configuration is required.

- Rating: 250VAC 15A, 125VAC 20A
- Contact: Single pole single throw(SPST)
- maintain type movement way
- 2 Screw terminal
- Mounting hole: 12mm

**Figure 7: Baomain Toggle switch SPST**

The switch that was chosen to be the most functionally efficient for the Automated Pet Feeder was the SPST switch, as the Automated Pet Feeder is being marketed towards individuals living within the United States, and only the United States. Therefore, a switch to break the circuit and prevent the flow of incoming power is all that is needed for the power supply of the Automated Pet Feeder, though it is worth to note that if the Automated Pet Feeder were to be marketed to other countries, particularly countries in Europe, a DPST switch would be needed to choose between input voltage sources of 120V or 240V. The specific SPST switch used for the power supply of the Automated Pet Feeder is the “Baomain Toggle switch SPST”. As seen below, the Baomain Toggle switch SPST can accommodate an electric potential of up to 125V at a current rate of 20A, as seen in the figure above. Considering that power is equal to the product of voltage and current, this switch has the ability to handle wattages of up to and including 2500watts [10].

### 3.3.4 Power Indicator

Many single-piece hardware components in electrical configurations include an indicator that conveys if the electrical device has a source of power, or not. Devices like these include smartphones, random access memory modules, desktop monitors, etc. These power indicators often become very useful in daily usage, or when troubleshooting electrical hardware for issues, as they remove the ever-present doubt that the power source might be causing the electrical hardware to malfunction. As many types of electrical hardware utilizes power indicators, it is no wonder that these indicators come in various sizes, and specifications, as they are intended to be used in various applications.

While light emitting diodes (LEDs) are some of the most common types of power indicators due to their low energy consumption and inexpensive cost, they are not suited for the use in the power supply for the Automated Pet Feeder as the input voltage is that of the United States household standard, which is 120V, and most LEDs require input voltages less than 5V. While using several resistors to reduce the voltage to an appropriate potential might be a solution, it is worthy to note that LEDs require direct current, and not alternating current. Since United States households provide power with alternating current, the LED power indicator would have to be used after several components in the power supply, most notably the transformer and bridge rectifier. This approach places the power indicator beyond two electrical components that have the possibility of failing, thus increasing the complexity in the event that troubleshooting is necessary because ambiguity at a glance is the result as the transformer or bridge rectifier could be the points of failure, and not the input voltage source.

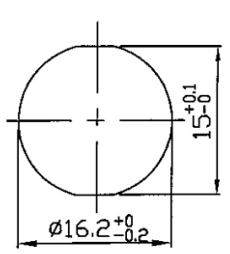
Rating	110VAC	<p style="text-align: center;">Mounting Hole</p> 
Insulation Resistance	DC 500V 100M ohm Min.	
Dielectric Strength	AC 1500V 1 minute	
Operation Temperature	-20°C~+80°C	

**Figure 8: Lamp Panel Yellow Neon 120VAC Solder Terminals with Bulb Datasheet**

The solution to this predicament is to utilize a power indicator that obtains its power directly from the 120V power source, thus eliminating any components that might create ambiguity when troubleshooting power source issues. While many light bulbs exist that require an input voltage of 120V, few possess the low-profile characteristic that would allow them to be used in a compact design. Though few, a solution does exist, and a 120V light bulb utilizing both alternating current and a noble gas for illumination, which allows the input power source to be directly connected to a power indicator. Figure 12 above depicts the datasheet for a “Lamp Panel Yellow Neon 120VAC Solder Terminals with Bulb” manufactured by Jameco Valuepro [7]. While the voltage rating stated in the

table is lower than the national household standard of 120V, it is important to note that devices must operate with a tolerance of ~5%, thus allowing this bulb with a rated input voltage of 110V suitable for the power supply.

### 3.3.5 Transformer

While several of the electrical components of the power supply of the Automated Pet Feeder require standard, household voltage of 120V, the majority of the electrical components that comprise the Automated Pet Feeder are integrated circuits and direct current motors. These integrated circuits and direct current motors typically operate at voltages less than or equal to 5V, and between 6V and 12V, respectively. Therefore, the input voltage of the power supply must be reduced in order for it to provide useful power to each component. While resistors can be used as a means of curtailing voltage, they do not provide clean, steady power, especially when the loads are drawing varying magnitudes of current over time, therefore the application of a transformer in the power supply unit partially solves this problem.

#### *Step-down transformer*

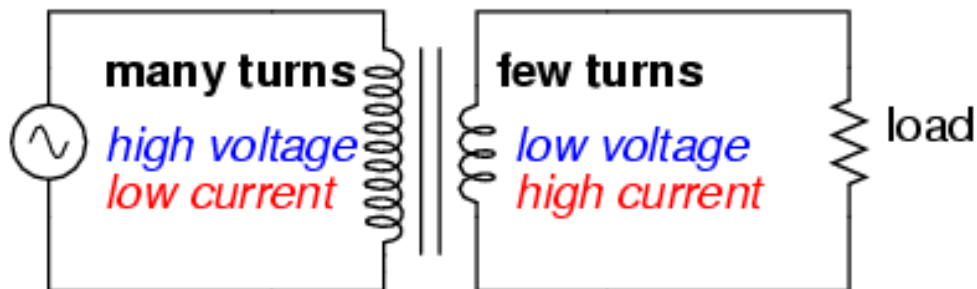

Figure 9: Step-Down Transformer

While it is quite obvious that transformers transform voltage, it is important to note that transformers can either increase voltage from one set of terminals to the other, or decrease voltage from set of terminals to the other. These two types of transformers are called step up transformers, and step-down transformers, respectively. They achieve their voltage transformation property by using a wire, typically copper, to create a series of turns about an insulating core. These series of turns produce an electromagnetic field, and this electromagnetic field then induces a current on the other end of the transformer, as the other end also has a series of turns about an insulating core typically using copper wire. Though the point of distinction is that for a step-down transformer, the amount of turns on the end with the desired low voltage must be less than the amount of turns on the other end, which has the power source, and consequently, higher voltage. The exact opposite configuration is true for step-up transformers [11].

As the voltage from our power source needs to be reduced, a step-down transformer will be used. The step-up transformer needed for the power supply of the Automated Pet Feeder had the requirement that its input voltage must be ~120V, and while its step-down

output voltage need not be the voltage explicitly required by any single component, its step-down output voltage must be regulatable by other components in order to be able to be used throughout the electronic components of the Automated Pet Feeder. This requires knowledge of many of the other components' voltage requirements, particularly the voltage regulators, which will be covered in a later section of this report.

One transformer that fit all of the above requirements is manufactured by Packard, though its specific product number is PF42440 [14]. The PF42440 has a primary voltage of 120V or 208V to 240V. This gives scalability to the Automated Pet Feeder as all that would be needed in the future to allow it to be marketed in European countries is a slight modification to the power supply, notably adding a DPST switch to select the correct input power source. The PF42440 also has a secondary voltage rating of 24V, thus making it ideal and compatible with most voltage regulators, as will be discussed later.

<b>Connection</b>	Wire Lead
<b>Hertz</b>	50/60
<b>Mounting Option</b>	Foot
<b>Output Option</b>	40VA
<b>Primary Voltage</b>	120/208 - 240
<b>Secondary Rating</b>	24

**Figure 10: Packard PF42440 Control Transformer Class II Foot Mount Datasheet**

### 3.3.6 Diodes

The importance of diodes in the design of the power supply for the Automated Pet Feeder is more easily understood from the perspective of the original power source. As previously stated, standard power, for households in the United States, has an electric potential of 120V, and although this voltage is reduced by the presence of a step-down transformer, the current still, however, remains as alternating current. It is worthy to note that in order for voltage to be transformed, the current must be alternating, though while alternating current is imperative to the functionality of the step-down transformer, alternating current is rather useless to the rest of the electrical components in the Automated Pet Feeder.

For this reason, a means to convert alternating current to direct current is required. While there are integrated circuit devices to perform this task, the preferred method was to design the alternating current to direct current converter in the schematic itself, as this provides more flexibility, and robustness than would a pre-build, integrated circuit to provide similar functionality. One fundamental electronic component that, when used in the appropriate configuration, can accomplish this is the diode, though to fully understand how this is performed, one must initially understand the functionality of the diode.

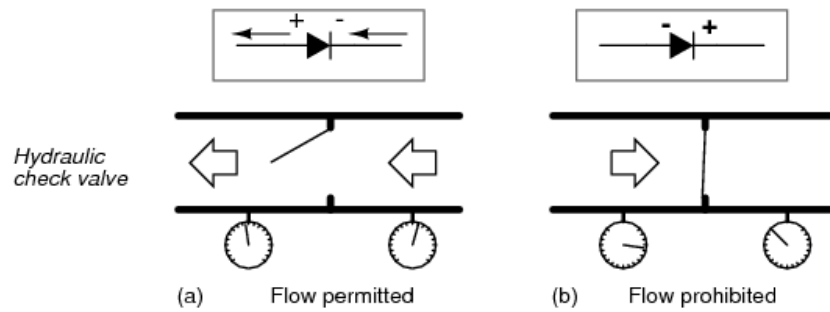

**Figure 11: Hydraulic check valve analogy: (a) Electron current flow permitted. (b) Current flow prohibited**

A diode is an electrical device, usually a semiconductor, that allows current to pass through it typically in one direction. Note that some diodes, most notably Zener diodes, allow current to in either direction under certain circumstances, though most diodes only allow current to flow in one direction. Consider the following figure above. The above image conveys an analogy of a hydraulic check valve to diodes. One can imagine the electrons trying to flow from left to right, thus being blocked, while electrons flowing from right to left are allowed to pass through [19]. It is important to keep in mind that electrons flow in the opposite direction of current, therefore if one were to think of this analogy but instead using current flow instead of electron flow, simply negate the directions and the analogy holds true.

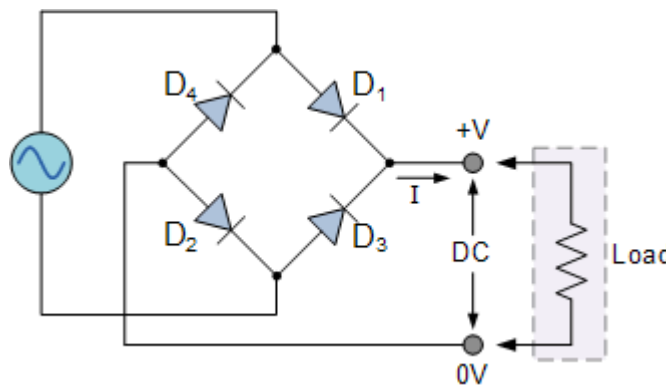
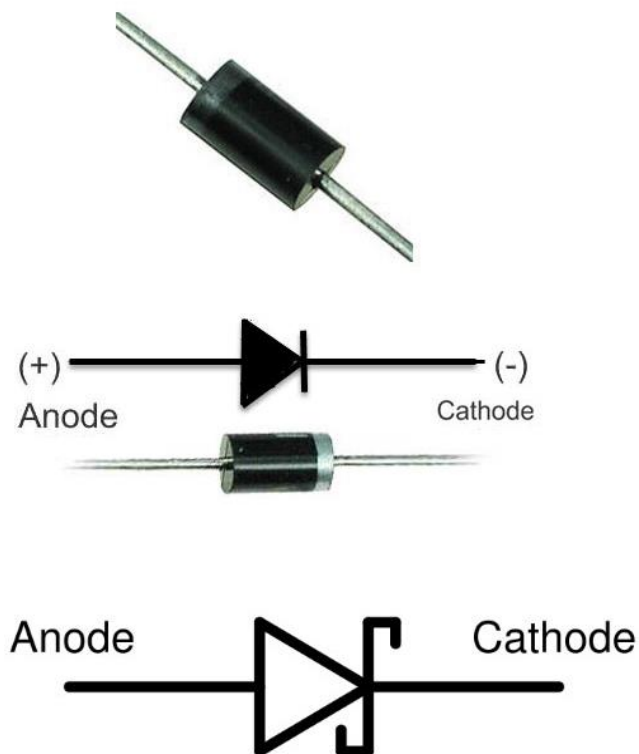

**Figure 12: Full Wave Rectifier**

Figure 15 is a visual representation of a circuit that employs four diodes to create a full wave rectifier [20]. As can be observed in the circuit, the diodes only allow current flowing from the source to pass through the circuit and onto the load. As the source provides alternating current, and thus the signal is sinusoidal, usage of four diodes in this configuration prevents the signal from producing cycles in the negative region on the load end of the circuit. As the signal can only produce a positive signal on the load end of the circuit, this current is no longer alternating between a positive and negative sinusoidal wave. While it may not be clean, direct current, it now has the potential to be stabilized by other circuit components that will be discussed in preceding paragraphs.



While most diodes serve the same, general purpose of allowing current to flow in a single direction, there are, however, prominent difference between the many selections available. Out of the many options available, three prominent types were considered when constructing the power supply. These three include Schottky diodes, Rectifier diodes, and Fast Recovery diodes. The first type of diode applicable in the construction of a bridge rectifier that will be covered is the Schottky diode. Schottky diodes are a type of semiconductor diode, though these types of diodes have a lower than normal forward voltage drop across their junctions. When current flows across most diodes, the voltage drop from terminal to terminal is typically between 0.6 volts and 1.7 volts, however, when current flows through a Schottky diode, the voltage drop from terminal to terminal is typically between 0.15 volts and 0.45 volts. As the power an object consumes is equivalent to the product of the current and voltage passed through this object, one can observe that the end result of having a lower voltage drop across a Schottky diode results in less power consumption. Schottky diodes also have the benefit of having a lower switching time interval, as the voltage required for a Schottky diode to remain active is lower than that of a regular diode, thus making it switch faster. This is all possible through the materials and engineering process used in the construction of Schottky diodes. Schottky diodes are formed by employing metal in conjunction with a semiconductor. This bond is formed at a semiconductor-metal junction, thus creating a Schottky barrier. As metal is employed, which is a conductor and thus acts as an anode, and the semiconductor as a cathode, this allows for far less voltage required for the diode to become operational, and thus current is allowed to flow.



**Figure 13: Fast Recovery, Rectifier, & Schottky Diodes**

This is one of the three diodes considered in the construction of the power supply for the Automated Pet Feeder, though it was observed that the Schottky diodes under consideration allow a maximum input voltage of 40 volts. Furthermore, the placement of the diodes used in the construction of the bridge rectifier is after the step-down transformer, therefore even though the voltage should theoretically not exceed 24 volts, transformers do not have built in voltage regulators, and their output voltage are proportional to their input voltage, unlike voltage regulators. Therefore, the possibility of having a spike in the voltage can occur on the step-down end of the transformer if the source voltage of the transformer receives a power surge. These types of power surges are more frequent in some areas of North America than others, though to allow the Automated Pet Feeder to attain as much of a broad market as possible, the assumption that clean power would always be supplied to the transformer was not an assumption that could be made. Thus, in the instance of a power surge, the voltage on the step-down portion of the transformer could be several times greater than the maximum permitted voltage for the Schottky diodes, which is 40 volts, which rendered Schottky diodes unsuitable for our design.

Another type of diode that has a possible application in the construction of a bridge rectifier are Fast Recovery diodes. Fast recovery diodes share a characteristic with Schottky diodes, as they recover from the changes in a sinusoidal signal faster than that of regular diodes, though Fast Recovery diodes exhibit this property substantially more than even Schottky diodes, as their name implies, Fast Recovery diodes primary function is to recover quickly from these changes in the incoming signal. Though to determine whether or whether one would choose a Fast Recovery diode for a bridge rectifier, it is important to understand why a short recovery time is needed. When a signal is rectified and converted from alternating current to direct current, this signal has a specified value that indicates how many times per second the signal alternates. This value is referred to as the frequency of the signal, and it is the responsibility of the diodes in the bridge rectifier of the circuit to prevent the signal from alternating. Depending on how many times per second this signal alternates, the diodes might be effective in rectifying the signal or not. As the frequency increases, conventional diodes typically cannot recover from change in direction quickly enough to be effective in rectifying the signal, therefore Fast Recovery diodes must be used as they have a short recovery time, and can be used in applications wherein a signal of high frequency must be converted from alternating current to direct current. However, the primary downside to Fast Recovery diodes is that since they have such a quick switching time, they utilize more energy than conventional diodes. Since houses in North America have incoming power with a relatively low frequency of 60 hertz, the quick switching property of Fast Recovery diodes would not be utilized in the application of the Automated Pet Feeder, therefore the the downside would be left as a result, which is consuming more energy while its fast switching gives no benefit in the current implementation [32].

Yet another type of diode that is applicable in the construction of a bridge rectifier is the Rectifier diode. These diodes have many similarities to the two types of diodes formerly stated, and their benefits and disadvantages also correspond to the disadvantages and benefits of diodes previously discussed. Rectifier diodes' primary application is in the

construction of bridge rectifiers, which is where they attain their name from. Unlike Fast Recovery, rectifier diodes do not have the ability to recover quickly from changes in alternating current, therefore their application in circuits that utilize high frequency signals is limited to none. Though since Rectifier diodes do not switch quickly, they are far more efficient in applications wherein a fast switching speed is not required, which results in saved energy. Furthermore, the Rectifier diodes chosen, do not have the limited input voltage of 40 volts max, as do the Schottky diodes. The Rectifier diodes chosen for the construction of the power supply for the Automated Pet Feeder has a maximum input voltage of 1000 volts, with a maximum current throughput of 3 amps. Therefore, this would in theory allow up to 3000 watts of power to flow through the power supply, if the rectifier were only being considered itself.

### Absolute Maximum Ratings

Stresses exceeding the absolute maximum ratings may damage the device. The device may not function or be operable above the recommended operating conditions and stressing the parts to these levels is not recommended. In addition, extended exposure to stresses above the recommended operating conditions may affect device reliability. The absolute maximum ratings are stress ratings only. Values are at  $T_A = 25^\circ\text{C}$  unless otherwise noted.

Symbol	Parameter	Value					Unit
		1N5401	1N5402	1N5404	1N5406	1N5408	
$V_{RRM}$	Maximum Repetitive Reverse Voltage	100	200	400	600	1000	V
$I_{F(AV)}$	Average Rectified Forward Current, .375 " lead length at $T_A = 75^\circ$	3.0					A
$I_{FSM}$	Non-Repetitive Peak Forward Surge Current 8.3 ms Single Half-Sine-Wave	200					A
$T_{STG}$	Storage Temperature Range	-55 to +150					$^\circ\text{C}$
$T_J$	Operating Junction Temperature	-55 to +150					$^\circ\text{C}$

**Figure 14: 1N5408 Data Sheet**

The specific diode that was eventually chosen for the power supply for the Automated Pet Feeder was a Rectifier diode, particularly the 1N5408. 1N5408 diodes are a popular form of diodes used for bridge rectifiers, and are especially popular in circuits that supply a load with a large amount of power, as 1N5408 diodes can, in theory, supply up to 3000 watts of power. As 1N5408 diodes are Rectifier diodes, they are primarily suited for applications wherein a signal with low frequency needs to be rectified, and since alternating current in houses in North America is 60 hertz, which is relatively slow, 1N5408 diodes are suited perfectly for this application. Furthermore, 1N5408 diodes do not switch fast, this allowing the Automated Pet Feeder to utilize as little power where it need not be used, which, in comparison to Fast Recovery diodes, would use far more energy. Altogether, the 1N5408 diode has the ability to supply a great portion of power to all the components in our circuit, which leaves the door open to possible upgrades to the Automated Pet Feeder in the future, while also being robust enough to support up to 1000 volts at its input, which allows it to withstand harsh environments as well.

### 3.3.7 Capacitors

While there are three fundamental passive components to electrical circuits, including the resistor, inductor, and capacitor, the capacitor is one of the most recognizable electrical components when looking at most printed circuit boards. This is primarily because of its wide spectrum of application in regard to circuit design, which include stabilizing power, to energy storage, signal filtering, and many more. Though to understand the applications of capacitors in the Automated Pet Feeder, one must understand the characteristics and functionality of capacitors. While capacitors come in many shapes and sizes, their general construction is the same for the most part.

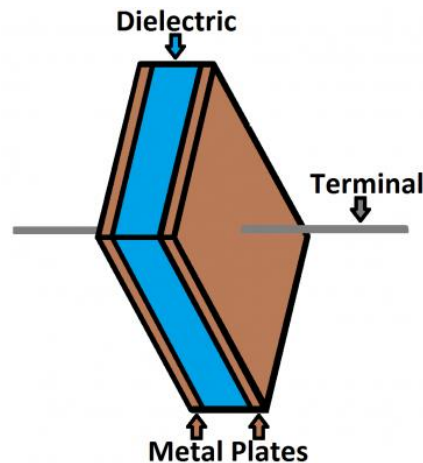

**Figure 15: Capacitor Construction**

Capacitors are constructed from two pieces of metal, with an insulators between them. This insulator is called a dielectric, and usually the two pieces of metal being separated are very thin. These pieces of metal are usually thin, long strips of sheet metal, wound in a coil. This allows the capacitor to be far more dense, and deliver more of its desired function in a smaller, as the smaller the distance between plates equates to a greater capacitance produced. The following equation represents the equation used in the construction of a capacitor:

$$C = \epsilon_r \frac{A}{4\pi d}$$

**Figure 16: Capacitance Equation**

As can be observed, the greater the surface area between the plates, the greater the capacitance produced. Conversely, the smaller the area between the plates, the greater the capacitance produced. The last parameter is a constant relating to the material used as an insulator for the plates. This is a constant that is specific to every insulator that behaves as a dielectric in a capacitor, though as can be observed, a larger constant is desired for applications requiring a larger capacitance. Altogether, these several parameters are used in constructing various capacitors for various applications, as these parameters are limiters to what can actually take place within each capacitor.

As current flows through a circuit, and into a capacitor, electrons carry a charge, or electric potential, that is equal to all other electron that they come in contact with. Though when these electrons flow into a capacitor, the dielectric insulator prevents the flow of electron, as that is the purpose of the insulator. This causes the saturation of negatively charged electrons on the incoming plate, and since the corresponding plate is separated by a, albeit thin, dielectric insulator, the excessive presence of negatively charged particles close by removes the negatively charged particles on the other side. This absence of negatively charged particles on the other side renders an imbalance of charges, and leave the other side with mostly positive charged particles. As one conductor is now negatively charged, and the other positively charged, yet they are unable to physically touch, this causes a strong attraction, which culminates in an electric field being produced. This creates the desire for the capacitor to discharge itself, and even out the imbalance in charge whenever possible, and this discharge culminates in energy. Altogether, capacitors use this technique to store energy at a specified electric potential [34].

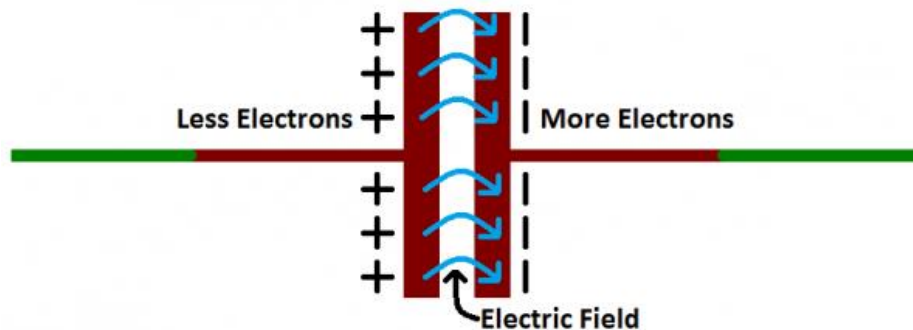

**Figure 17: Electron Representation in a Capacitor**

The ability of capacitors to absorb and retain energy causes them to be a crucial component of various electric circuits, as primary power sources typically do not provide a stable source of power. The primary goal of an electrical circuit is to provide, and distribute power to one or several loads that may be located throughout the circuit. These loads can consume great portions of energy, and when these changes in the consumption of energy change quickly over time, the voltage supplied to other components in the circuit can be affected. While some components that do not rely on a tight electric potential range may not be affected, as in the case of electric motors, other electronics in the circuit, especially the ones relying on semiconductors required finely tuned voltage levels, and these voltage levels must not vary by much or else components might fail to perform their designated function. Thus, the inclusion of capacitors within the circuit helps to compensate for these momentary voltage drops caused by significant loads, and thus allow clean, stabilized power to be provided to the components wherein they are implemented.

While all capacitors employ the same mechanism in regard to physics, they do, however, come in different shapes and sizes, and employ different materials in their constructions, which ultimately renders some more useful for certain applications than others. Several types of capacitors that are very common in electrical circuits include Ceramic capacitors, Aluminum and Tantalum Electrolytic capacitors, and Supercapacitors. Ceramic capacitors are the most commonly used capacitors in circuit design, as they are

inexpensive, maintain a low profile, and have an extremely low to relatively low capacitance rating. Ceramic capacitors also have less leakage current than the other capacitors in comparison, which allows for them to be more energy efficient when implemented. The benefits of Ceramic capacitors end there, and their primary downside is their inability to store large portions of energy, as they have a relatively low capacitance rating. This low capacitance rating allows them to be useful in circuits that employ signals of high frequency, and for decoupling and coupling applications. Though for applications wherein a significant portion of energy needs to be stored, ceramic capacitors' limited capacitance, therefore limited energy storage, become a problem and render them ineffective.

Another prominent type of capacitor that is commonly used in electrical circuitry is the Supercapacitor. Supercapacitors, like Ceramic capacitors, have their benefits and drawbacks. While they are not as widely used in circuit design as Ceramic capacitors, Supercapacitors exceed the functionality of Ceramic capacitors in one particular way. Supercapacitors have the ability to store large amounts of energy, comparable to even batteries, though since they are capacitors, discharge is still nearly instantaneous, which allows them to have many applications wherein they function similar to batteries.

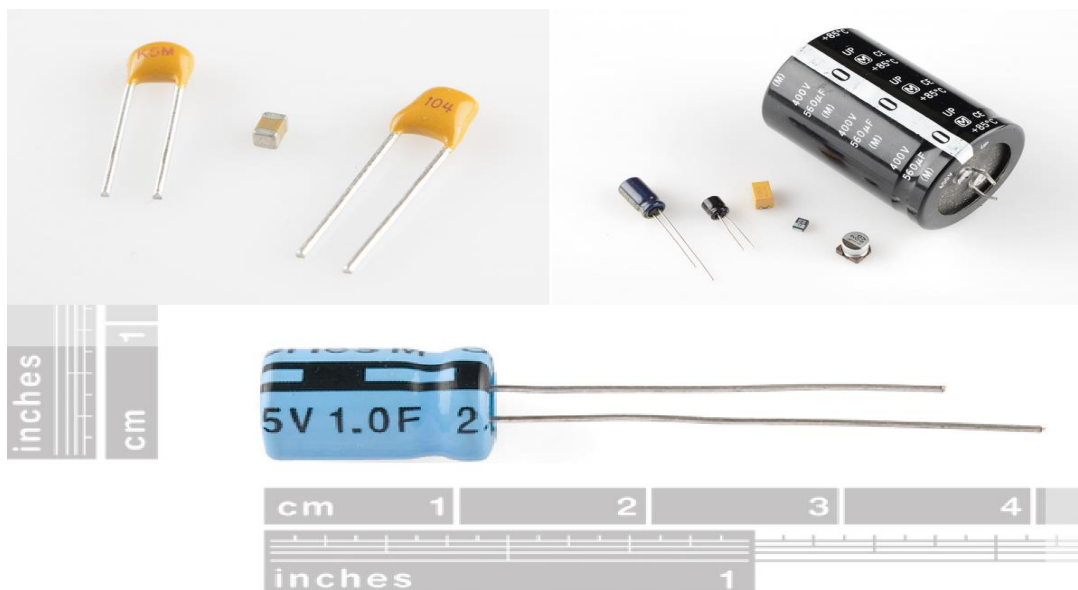

**Figure 18: Ceramic, Electrolytic, & Supercapacitors**

The primary disadvantage of Supercapacitors is that they are unable to operate at moderate to high voltages, usually voltages no more than 2.5 volts. This causes their usefulness in most applications to be limited, as even most low power circuits require an input voltage of 3.3 volts or greater. Thus, Supercapacitors are not as common in electrical circuits as their Ceramic capacitor counterpart. This disadvantage can be addressed if the capacitors are configured in series, which then allows the total input voltage to be greater than that of a single Supercapacitor. This configuration, however, reduces the total capacitance, and consequently reduces the amount of energy that may

be stored, thus limiting the entire purpose of implementation. Nonetheless, under special situations, Supercapacitors may be useful.

Yet another type of capacitors that are more commonly used than Supercapacitors are Aluminum and Tantalum Electrolytic capacitors. Both of these types of capacitors are commonly referred to as Electrolytic capacitors, and while they may not be able to replace Ceramic capacitors nor Supercapacitors, they are more versatile than both of the former as they share the advantages of both to a lesser extent. Unlike Ceramic capacitors that have a limited capacitance, Electrolytic capacitors typically have larger capacitance values, thus allowing them to store greater portions of energy. Electrolytic capacitors are also not limited to low voltages like Supercapacitors, as they can easily handle voltages in the triple digits. This all culminates in Electrolytic capacitors being able to function well in applications that require relatively low capacitance, and also applications that require capacitors with high capacitance together with high voltage.

After careful consideration of the various types of capacitors that could be used for the power supply for the Automated Pet Feeder, Electrolytic capacitors were chosen as a single set of Electrolytic capacitors could possess an assortment of several values that satisfied all function in the power supply. The specific Electrolytic capacitors chosen included 25V2200uF, 25V10uF, and 25V100uF [35]. Three of the 25V2200uF capacitors were placed in parallel after the bridge rectifier, thus forming an equivalent capacitance of 6600 microfarads. This capacitor bank was specifically designed to eliminate significant changes in the voltage being delivered, and to create a constant signal from the rectified signal, which is why such a high capacitance was needed, thus allowing the capacitor bank to store large amounts of energy, and react accordingly if the input voltage drops, or a load on the other end experiences a significant surge in the consumption of power, and attempts to cause a voltage drop. The other capacitors, 25V100uF and 25V10uF, are placed before the voltage regulators, as that is directly before the load and stabilizes any additional sudden changes in power by the loads.

### 3.3.8 Voltage Regulators

While the transformer in conjunction with the bridge rectifier and capacitors supply a steady, clean source of voltage and current, this voltage still, however, has an electric potential not suitable for any of the microelectronics and motors that it will eventually supply. Thus, this voltage must be reduced before useful power can be supplied to the various components. There are two common ways of reducing voltage to a useful electric potential. One of these ways is to use a resistor, or as many as are needed in series to achieve a large enough voltage drop across these resistors, thus causing the remaining voltage supplied to the load to be low enough so that it is useful.

This method of reducing voltage only works for loads that consume a constant source of current, which therefore are always consuming the same amount of power. As voltage is equal to the product of current and resistance, the voltage drop across each resistor will only remain the same if the current passing through the resistors remain the same. Thus, if the load is dynamic, and consumes varying amounts of power over time, the current passing through these resistors will fluctuate, thus also changing the voltage drop across

these resistors, and ultimately providing too great or too little of an electric potential to the load, which can be damaging to the load in some instances.

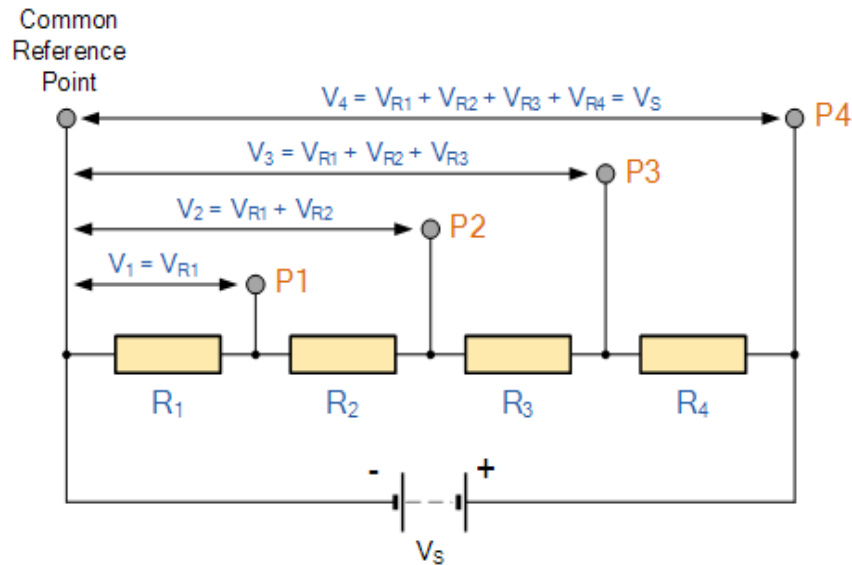

**Figure 19: Voltage Drop Across Several Resistors**

Although the Automated Pet Feeder has several components, for instance, LEDs, that utilize a static magnitude of power, the majority of the electrical components within the Automated Pet Feeder do not have this simplicity as a characteristic. Most electrical components in the Automated Pet Feeder require differing levels of current and power at different moments, therefore a solution to reduce voltage that is not dependent on the flow of current was crucial. Through research, it was determined that voltage regulators were the ideal electrical component for this task, though how voltage regulators accomplish this is crucial to determining the most appropriate voltage regulator to use.



**Figure 20: Linear, Switching, and Zener Diode Voltage Regulators**

While the primary functionality of all voltage regulators is the same, how these voltage regulators perform varies throughout the several type. Three prominent types of voltage regulators will be covered, which include Linear voltage regulators, Switching voltage regulator, and Zener diodes. Linear voltage regulators are one of the most common types of voltage regulators. They achieve their function of regulating voltage by altering the series resistance of portions of the regulator depending on the voltage being fed back.



Thus, ultimately transforms the circuit into a voltage divider circuit, utilizing the same technique of using resistance to reduce voltage as before, though in a dynamic way that allows for a specified range of voltages on the input, yet only one voltage on the output. The primary disadvantage to Linear voltage regulators is that a significant voltage drop occurs across the input and output terminals, thus causing a varying magnitude of power draw depending on the input voltages. As Linear voltage regulators work with an arbitrary input voltage within a certain range, and must output a specified voltage, the difference between input voltage and output voltage must always be the voltage drop across the Linear voltage regulator. Thus, if the input voltage were at the top of the specified interval, a maximal voltage drop would occur across the input and output terminal, culminating in the maximum amount of power loss if the maximum current is also attained as well. Therefore, Linear voltage regulators are best suited for applications wherein energy efficiency is not the primary objective, and can be sacrificed in light of how inexpensive Linear voltage regulators are in comparison to their competition.

Another type of voltage regulator that was considered in the construction of the power supply for the Automated Pet Feeder was Switching voltage regulators. Switching voltage regulators are designed for the very situations wherein Linear voltage regulators fail, that is, when the input voltage is far from the desired value of the output voltage. Switching voltage regulators allow for a much larger interval of input voltage, while being far greater in efficiency than Linear voltage regulators. This efficient voltage regulation come at a price, and this price translates to greater cost per regulator and an increased electronic interference that might be catastrophic to other devices within the circuit. Thus, unless power efficiency is critical for the circuit on a whole, switching regulators are typically avoided.

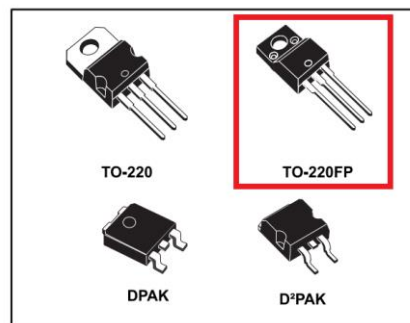

- Features**
- Output current up to 1.5 A
  - Output voltages of 5; 6; 8; 8.5; 9; 12; 15; 18; 24 V
  - Thermal overload protection
  - Short circuit protection
  - Output transition SOA protection
  - 2 % output voltage tolerance (A version)
  - Guaranteed in extended temperature range (A version)

**Figure 21: L78 Series Voltage Regulator Datasheet**

Yet another type of voltage regulator is the Zener diode. While Zener diodes have functions far beyond voltage regulation, their ability to have a constant breakdown voltage makes them a surprising candidate for voltage regulation. Zener diodes have the special property that any voltage beyond the breakdown voltage will be routed to ground, though

the disadvantage of Zener diodes is that they are slow in reacting to change for a relatively short period of time even after the breakdown voltage has been attained, thus for sensitive microelectronics that might be depending on a voltage source that will not exceed a certain value, Zener diodes would fail to achieve this. Zener diodes also typically have lower maximum throughput current, which prohibits them to provide a great portion of power to their loads. Therefore, there are few applications that would render Zener diodes a great choice for regulating voltage, though they are such a simple solution that renders them a device worthy of consideration. One prominent area wherein Zener diodes are useful is when a signal, whether alternating current or direct current, must be clipped to allow a maximum throughput to not exceed a specified magnitude. As Zener diodes possess a breakdown voltage, the voltage across the Zener diode will be the specified desired magnitude, and the remaining will be sent to ground, thus clipping the signal [36].

After careful consideration of the three options for regulating voltage in the power supply for the Automated Pet Feeder, it was concluded that Linear voltage regulators would be utilized. While they do have terrible efficiency, it was realized that these voltage regulators would be used in conjunction with the 120 volts supplied by the output of a house, thus even the situation wherein the highest inefficiency occurs, which is having the largest voltage drop across the Linear voltage regulator, while drawing as much current as possible, this would only translate to several watts being wasted through the dissipation of heat. Thus, the wasted energy was a minuscule sacrifice in comparison to the cost and complexities encountered with Switching regulators, and poor performance of Zener diodes. The Specific Linear voltage regulators chosen were L7805, L7806, L7809, and L7812. These voltage regulators have output voltages of 5 volts, 6 volts, 9 volts, and 12 volts, respectively. This allows for the power supply for the Automated Pet Feeder to deliver current on several voltage rails to the various components [37].

## 3.4 Doors

One of the main features of the pet feeder is to have a door that opens and closes depending on a given scenario. For instance, if pet Y is trying to eat from pet X's bowl, then the pet feeder would close with enough time to not allow forbidden access to pet Y. On the other hand, if pet X has already achieved his food intake for his given diet plan then the feeder would close to avoid over feeding the pet. This feature must work as planned because this feeder can be used for all types of pets that require a dry food diet plan. A lot of thought went into what style doors would be used for opening and closing the pet feeders bowl. Thoughts of aesthetics and functionality were of most concern. It was decided that the feeder would take on more of a cubic shape, so the option of a rotating latch would not be feasible. Both the tambour and sliding style doors seemed to be most practical for the application at hand.

The tambour door is a great candidate for the pet feeder. A tambour door is a door that can roll or slide, up or down along a predestined track. This application can be seen in different storage devices such as a small wooden bread storage compartment. A key feature to the tambour door is the little space that it would occupy when the pet feeder is in the open state. Since the door can rotate to a bent track and move from a horizontal state to a vertical state when opening, this would allow for the door to be as close to one of the

wall in the pet feeder thus taking up less space in the feeder. We are trying to minimize the size of the pet feeder as much as possible and this door option optimizes the space used. Figure one shows a blueprint for a desk compartment that will utilize a tambour door option for opening and closing. If you look closely at the diagram you will notice the predefined track that the door will follow when opening and closing. The track takes a path close to the already existing shape of the compartment and takes up less space by doing so. Aside from the little space it occupies, tambour doors give a unique and sleek look to the pet feeder. From the competitor products seen on the market, most tend to use a solid sheet of plastic to open and close the feeder. Given the small-scale application for the pet feeder it can be argued that the tambour door may not be as sturdy as a solid sheet of material as seen in other designs. There is much concern of a pet stepping or exceeding the threshold of the tambour door.

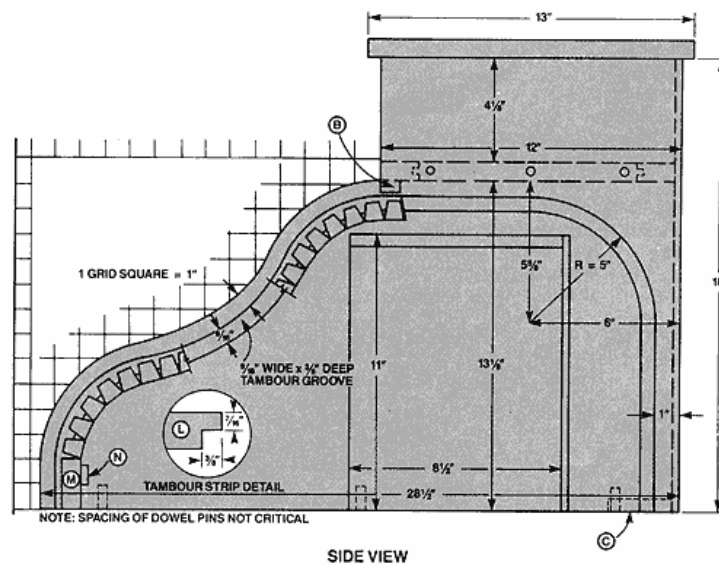

**Figure 22: Blueprint for a tambour door application**

sliding door used to open and shut the pet feeder is another option that was discussed when deciding on what style door to use. This option would add to the simplicity of construction when looking from a design aspect. Given the square shaped opening, we would utilize a square sheet of plastic that would glide back and forth on a predefined track. This design would allow us to make the door as thick as needed for a more sturdy option thus making it more pet safe. Simplicity is great for design but the amount of space that would have to be separated would greatly be affected. The only way this option would work is to slide the door in and out of the dog feeder, which would effectively require a separation from the bottom portion of the feeder to the top portion. This could cause design constraint that may not be achievable.

A lifting door that pivots at one end was another option of the pet feeder. The door would operate the same as Draw Bridge. This would be a great option since the door would remain outside of the feeder regardless of what position it is in. The fact that the door remains on the outside of the pet feeder assists in trying to maintain as small a feeder as possible due to size limitations and requirements set when designing the pet feeder. The

issue with this style door is that it leaves for easy damage. The door would be standing upright when open and completely exposed to the pet. If the pet decides to physical contact with the door, this could lead to damage to the pet door and possible the structure of the pet feeder. Not only could it damage the pet feeder, if the pet decided to use the door as a chew toy it could lead to possible serious injury. For this reason, it was decided that this style door would not be a feasible option for our design.

### 3.5 Motors

When designing the pet feeder, the manner in which the food would be dispensed along with how the food door will operate was in great debate. There are so many options to achieve these needs. Testing will need to be conducted to decide what style motor will be connected to the rubber paddle wheel that can be found in many commercial style manual dry food dispensers. It was decided that the best style motor for operating the food cover door, would be to use either a servo motor or a stepper motor. Some features used when choosing the motors were size, torque, rotations per minute(RPM), accuracy, and use of application.

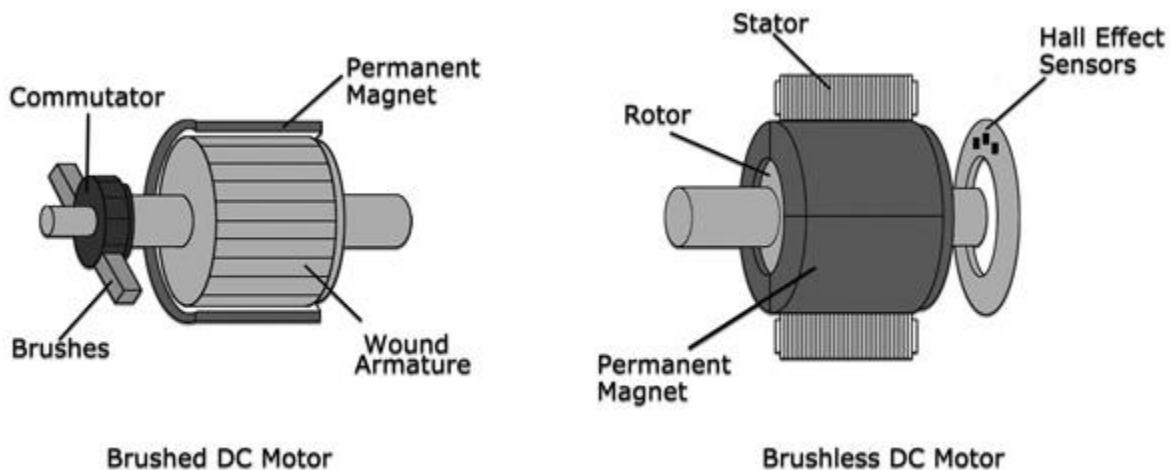

**Figure 23: Typical Servo Motor (top left), Typical Stepper Motor (top right), Typical DC Motor (bottom)**

### 3.5.1 Brushed Motors Vs Brushless Motor

The decision to use either a brushed or a brushless motor for the food dispenser was more involved than anticipated. There are many benefits for each application. One of the main requirement that needed to be met was that the motors needed to be as quiet. The reason for such quiet motor is due to not wanting to startle the pets. At times pets can become defensive to new contraptions and noises and may lead to the pet creating a fear to the feeder. By selecting a motor that can assist in lower noise levels would be ideal to ensure product satisfaction.

Brushed motors use wire coils that are wound on the rotor. When powered this armature spins that simulates a two-pole electromagnet [13]. A magnetic field is then generated around this armature. This creates a push and pull effect between the stationary outer magnets and inner armature. This is what creates the continuous rotation. If it is desired to reverse the direction of rotation, all that is need is to reverse the polarity of the power source to the connectors [13]. Brushed motors are usually utilized under DC power sources, which is ideal for the pet feeder application. Another great feature of brushed DC motors is, under fixed speed applications, a controller is not required. This helps when trying to keep in mind the size and price constraints of the pet feeder.



**Figure 24: Example of Brushed and Brushless DC Motors**

Brushless motors use a permanent magnet as its outside rotor. It also uses three phases of driving coils and a specialized sensor used to recognize its current position [13]. Based on its position, the sensors will send out reference signals to the controller. Then the controller can send out sequential phases one after the other. Some features of a brushless motor are better speed versus torque characteristics, high efficiency, longer life span, and noiseless operation. It can also be mentioned that a brushless motor is quieter than a brushed motor. This is of great importance for the application in which it will be used.

After much debate, our group decided that a brushless DC motor would be a better fit for the automated pet feeder. Although it will require an additional piece of hardware due to the need of a controller to operate a brushless motor, we still feel that it will be more

beneficial versus a brushed motor. One of the greatest deciding factor was the fact that a brushless motor is known to produce less noise than a brushed motor. It is important that the noise of the motor does not startle the pet because this could cause the pet to not want to interact with the feeder. Much testing will be needed to ensure this will not become an issue for the user.

### 3.5.2DC Motor

When choosing which DC motor to pick for the pet feeder, one of the biggest concerns was how much resistance can be applied before the motor would fail. This was in question since it is figured that some dry food pebbles may get stuck between the rubber paddle and the food reservoir wall. The motor needs to be powerful enough to continue spinning to force the blade of the paddle to bend and continue dispensing the food into the pet bowl. This feature needs to operate consistently without failure or the pet may not be fed properly which could lead to malnutrition for that given day or even longer. For that reason, multiple test runs under different test loads must be performed to ensure proper functionality.

Operating voltage was another feature that needed to be taken in account for. Collectively it was decided that the feeder would be have an AC to DC converter that would supply a maximum of up to 24 volts. Although 24 volts would be available for use at a given moment, we also wanted to make the pet feeder a low power consumption device. The choice to use a DC motor with a nominal operating voltage of 6 volt, was in effort to make the feeder consume less power. Not only is the operating voltage a concern, but being able to supply the proper amount of voltage needed to have a proper rotation speed.

The speed at which the motor will spin needs to be slow enough in order to give the scale that will be located below the bowl, enough time to calculate how much has been dispensed. For this reason, the feature of a low RPM DC motor is in need. If the motor is spinning at a rate that the scale cannot process fast enough to operate correctly, the feeder could potentially be over feeding the pet. With the pet's nutrition having to be taken into consideration, this feature would also be of great importance to ensure proper operation. It is known for DC motors to continue spinning after it has been commanded to stop. This issue could be solved if the motor rotates at a very low RPM's.

How big or small the DC motor would also need to be taken in account for. The pet feeder needs to be designed in such a manner that it does not take up much space. With the size limitations in place, all parts used in constructing the pet feeder needs to be small enough to meet the requirements. When it comes to DC motors, size usually means less power and less torque. It was necessary to ensure the motor was small but supplied the needed torque and rotations per minute needed. Things that are small but strong tend to be a little on the pricier side when purchasing. Below is a data sheet [18] on a DC motor that may be used during implementation of the automated pet feeder.

**370S series Ø24.4 mm 4.9-19W**

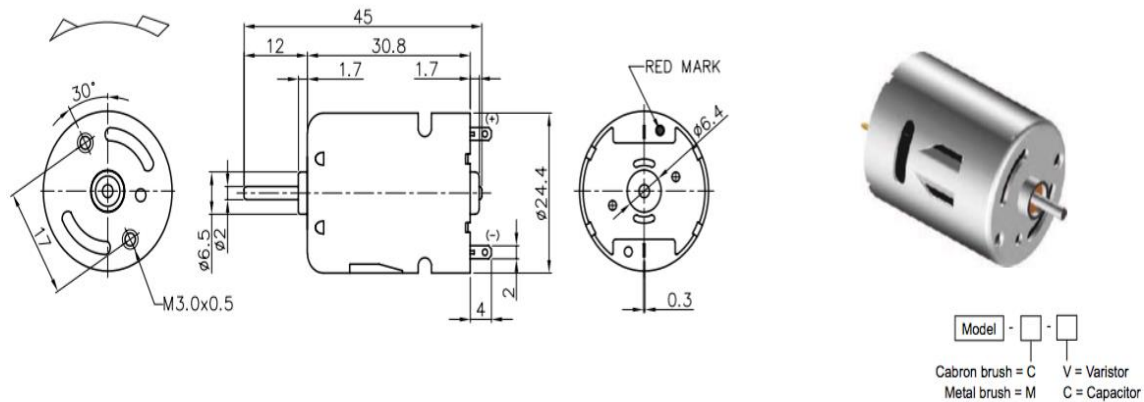

MOTOR DATA				
Part name	370S-5028P-C	370S-4530P-C	370S-3370P-CV	370S-16235P-CV
Diameter (mm)	24.4	24.4	24.4	24.4
Length (mm)	30.8	30.8	30.8	30.8
Nominal voltage (V)	3.6	6	7.2	15
Nominal speed (rpm)	16200	24000	14265	7500
Nominal torque (mNm)	8.0	7.7	7.2	6.1
Nominal current A	5.8	5.5	2.0	0.5
No load speed (rpm)	19000	29000	16500	9700
No load current A	1.00	0.80	0.48	0.10
Stall torque (mNm)	46.7	52.8	48.5	32.9
Starting current (A)	28.0	29.2	12.2	2.6
Output (W)	14	19	8.4	4.9
Efficiency (%)	66	59	81	62
Operating temperature deg. C	-10..+60	-10..+60	-10..+60	-10..+60

**Figure 25: 470S Series Specifications**

### 3.5.3 Servomotor Vs. Stepper Motor

When it comes to opening and closing the food cover door, a standard DC motor did not seem to meet the product requirements. The pet feeder's door only needs to open and close within a small range. The door will only be moving approximately a few inches when opening and closing. Since the door will be moving along a predefined track and the door being fairly light, the selection of motor does not need to be too powerful in terms of torque. The main requirements for the motor controlling the food cover door, is that it needs to operate accurately and quickly. When referring to accuracy, we are referencing the fact that the motor needs to be either fully closed or fully open. There should not be a case where the door is left in any other position other than fully open or fully closed unless it is transitioning from one state to the other. When quickness is mentioned as a requirement, this is suggesting that the motor needs to be able to close the bowl with sufficient enough time that the pet does not have the opportunity to interrupt the normal course of motion. If the door closes too slow and the pets interfere with the motion of the door, either the doors functionality can be hindered or damaged, or the pet can possibly get injured. Although there will be safety measure taken in account if this situation does arise with the use of sensors, the faster the door closes the less chance of a pet disturbing

this process is lessened. Both the stepper motor and servo motors can be used to achieve this goal.

Servo motors are used in multiple different applications. Although servo motors tend to be small, they are known to be powerful and very energy efficient. A servo motor consists of a DC motor, potentiometer, and a control circuit. All components are located within the servo enclosure. The motor is connected by gears that control the output wheel. When the motor rotates, the potentiometer resistance changes and the circuit can know exactly how far it is moving and in what direction it is moving. This is all controlled by electrical pulses of different width, also known as pulse width modulation, through a control cable. The pulse width will determine in which direction and how far the motor will move [5]. The motor will account for the distance needed to travel and will adjust its speed as necessary to arrive quickly yet accurately. It will continually send signals of its position to ensure the motor is in the correct position until a command to move is sent again. This feature is great because the pet feeder needs to know precisely where the door is positioned when operating. Another great feature of servo motors is that they run on both AC and DC power supplies. Although we will be utilizing mainly DC power for most of our electrical components, it is better to have the choice if needed.

Stepper motors is another option for operating either the food door cover or even the food dispensing paddle wheel. A stepper motor has no brushes or commutator like that found in a DC motor. Unlike DC motors, the stepper motor has a rotating permanent magnetic rotor interior and rotating coils around the perimeter. Each tooth of the rotor alternates between “north” and “south” poles. The surrounding electromagnets that alternate between electrical states, is what causes the rotation of the rotor due to the repelling and attracting interactions between the poles and magnets. [5] The benefit of using a stepper motor would be the ability to control movement by defined steps or angles of movement in the motor. Another great feature is that they tend to be cheaper when comparing to a servo motor. The downside to using a stepper motor is that they tend to move in a jerking fashion due the calculated steps of movement.

## 3.6 Motor Shields

Motor shields are a preferred component when powering various motors. Most motors usually take a lot of current, typically around .5 to 1 amp and in some cases more. An Arduino can only usually put out an average of 20 to 30 milliamps at each pin. Since not many motors can run off these Arduino pins safely and efficiently, so we need the use of a motor shield. Motor shields offer many features and benefits that allow for better control of each individual motor. Directions control is one of the biggest features of a motor shield. A motor shield allows for motor direction reversal, which takes away the need for a breadboard and limiting the amount of soldering necessary [84]. This feature will be greatly utilized when opening and closing the food door. The motor needs to be able to drive forward and in reverse during normal everyday operations. This can only be achieved by reversing the polarity of the input voltages of the motor and the motor shield can achieve this feature with ease.



A motor shield can allow for use of much higher amounts of current. They also give for a wide range of voltages as well. Since there is a possibility of one motor running on 6v and the other running at 12V, a motor shield would be ideal since most Arduino's cannot usually provide various voltages that may be needed. This will allow for a wider range of voltages and a much higher current that can be available to the motors now. Troubleshooting a system can be simplified by using motor shields as well. If something fails, the motor shield could protect the rest of the system from further damage. This is a great feature since we will be doing much testing with different motors under different loads and we wouldn't want to damage any other components when performing these tests. The Adafruit Motor/Stepper/Servo Shield for Arduino v2.3 Kit allows for the control of up to 12 DC motors or 64 stepper motors and consists of up to five select pins. This motor shield uses a TB6612 MOSFET driver that has a very low power consumption rating along with a 3A current capability [Qureshi, Asim]. This is great because it can control many motors at the same time but seemed a little too much for the application of the automated pet feeder.

With the SainSmart L293D Motor Drive Shield coming in much cheaper than the Afruit Motor/Stepper/Servo Shield for Arduino v2.3 Kit, this component was a better option for the automated pet feeder. This motor shield allows for the control of 4 DC motors or 2 Servo motors which would be more than sufficient for the automated pet feeder since the system will only require the use of only 2 motors in total. Another wonderful feature of this motor shield is the fact that it can run motors up to 25V, which is impressive for its price point and size.

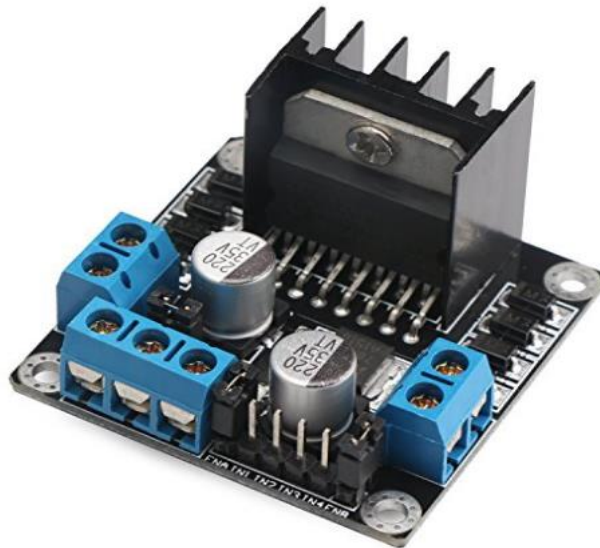

**Figure 26: SainSmart L293D Motor Drive Shield**

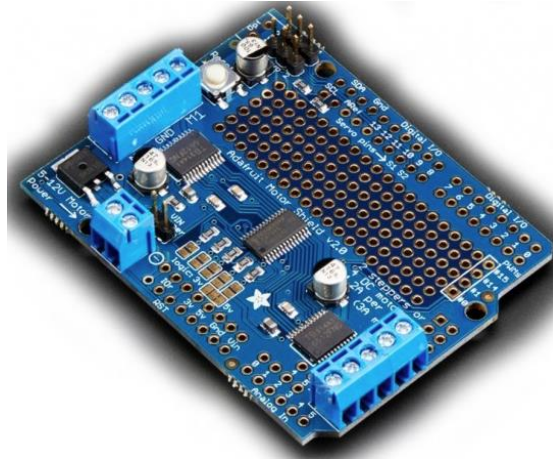

**Figure 27: DROK L298N Motor Drive Controller**

After careful consideration it was decided that the SainSmart L293D Motor Drive Shield would best suit the needs of the automated pet feeder for multiple reasons. The fact that it was at a lower price point than many other motor shields on the market would help keep the cost down for the customer which helps with the automated pet feeder requirements of a cost-effective product. Although it is cheaper than other motor shields in the market, it meets the requirements of being able to control the two motors that will be utilized in the design of the automated pet feeder. Its small size is another feature that helps with the design aspect as well. With the size coming in at, 2.68inch x 2.17inch x 0.79inch, this helps in keeping the pet feeder overall size limitations to a minimum which is a big plus when designing.

### 3.7 Water Pumps

The automated pet feeder will have feature of having a water reservoir that will pump water into a bowl that way the pet will always have access to a fresh supply of water. If the pets bowl is getting low on water, a signal will be sent to the microcontroller to turn on the water pump that will pump water from the reservoir to the bowl. Some features to take in account would be rate of displacement, size, noise level, and power rating. The pump needs to be able to pump the water at slow enough rate that gives the scale below the bowl, enough time to calculate how much water has been dispensed and signal weather to continue dispensing water or to shut off the water pump. Another attribute is that the pump needs to be able to hold back any water from leaking into the bowl when the pump is in standby mode. Any leaks can lead to an overflow of water into the bowl and potentially onto the resting surface of the feeder. The pump must also operate at a low level of noise. Like the motors that will be selected for the food dispenser and the food door cover, the pump cannot operate at a level of noise that will alarm the pet. The feeder cannot cause an adverse reaction based on loud operating motors or moving parts. Lastly the pump must also operate at or below the 24 DC volts that are available to the pet feeder system.

One option for the water pump will be a DC brushless motor submersible water pump. This option allows for the pump to be mounted inside of the water reservoir [17]. By

mounting the pump inside of the reservoir, this allows for less space to be accounted for in the feeder thus assisting in meeting the feeders overall size requirements. Not only does mounting the pump inside the reservoir help with the size requirement, by being submerged in water the water will help in lowering the noise level that may be produced by the motor. To also ensure for low noise levels, a brushless DC motor will also help in this requirement.

The other choice would be to utilize a pedestal sump style pump that will get mounted outside of the water reservoir and pump the water from the reservoir to the water bowl. Though the pump may not get the help of lower the noise level by being submerged in water, this issue could be handled by the use of a brushless DC motor pump.



**Figure 28: Example of a Brushless Submersible Water Pump**



**Figure 29: Example of a Pedestal Sump style water pump.**

The fact that the motor will be in a dry environment allows for the motor to usually last longer than the submersible pump. Lastly the pedestal sump pumps tend to be a lot cheaper in comparison to a submersible style water pump. By keeping the cost down on the water pump will assist in our overall goal in keeping the cost down to a minimum.

## 3.8 Water Reservoir Sensors

In order to alarm the owner of the pet when the water reservoir is running low on its water supply, the implementation of some type of sensors must be implemented. The sensor needs to be able to detect when the water level is below a given threshold and send a signal to the microcontroller to then send the warning to the user. The method chosen would need to perform consistently without failure due to the level of importance it is to ensure the pet has a constant supply of water. The sensors need to be waterproof, small in size, and cost efficient. There are numerous tutorials on the worldwide web that give step by step instructions on how to construct a cost water level indicator circuit. If this doesn't suffice for the pet feeder's requirements there are other all in one systems available that can easily be integrated into our system with ease.

Constructing a water level indicator following a simple online circuit diagram tutorial [16] could help in reducing the cost level to a minimum. This is a fairly straight forward system that works of transistors, resistors, Light Emitting Diodes (LED's), and some cables. The system can be easily scaled down or up depending on the needed applications. For instance, if you wanted 5 levels of measurement, then 5 transistors, resistors, and LED's will be required. When examining the circuit in the figure below, the wire coming from the top LED and going to the lowest point of the reservoir is the reference wire. The rest of the wires coming from the LED's are placed at their respective levels based on the level of the LED. For example, the lowest LED corresponds to the lowest reading point in the reservoir. While water is in contact with a wire, the corresponding light will be lit. If the water falls below level of a wire, that wires light will go off. For the automated pet feeder's application, we will send the user a notification and sound a buzzer when the water level reaches approximately 10% water supply left in the reservoir. This system is both cost effective and easily integrated into the existing system in the automated pet feeder.



**Figure 30: Right angle float sensor.**

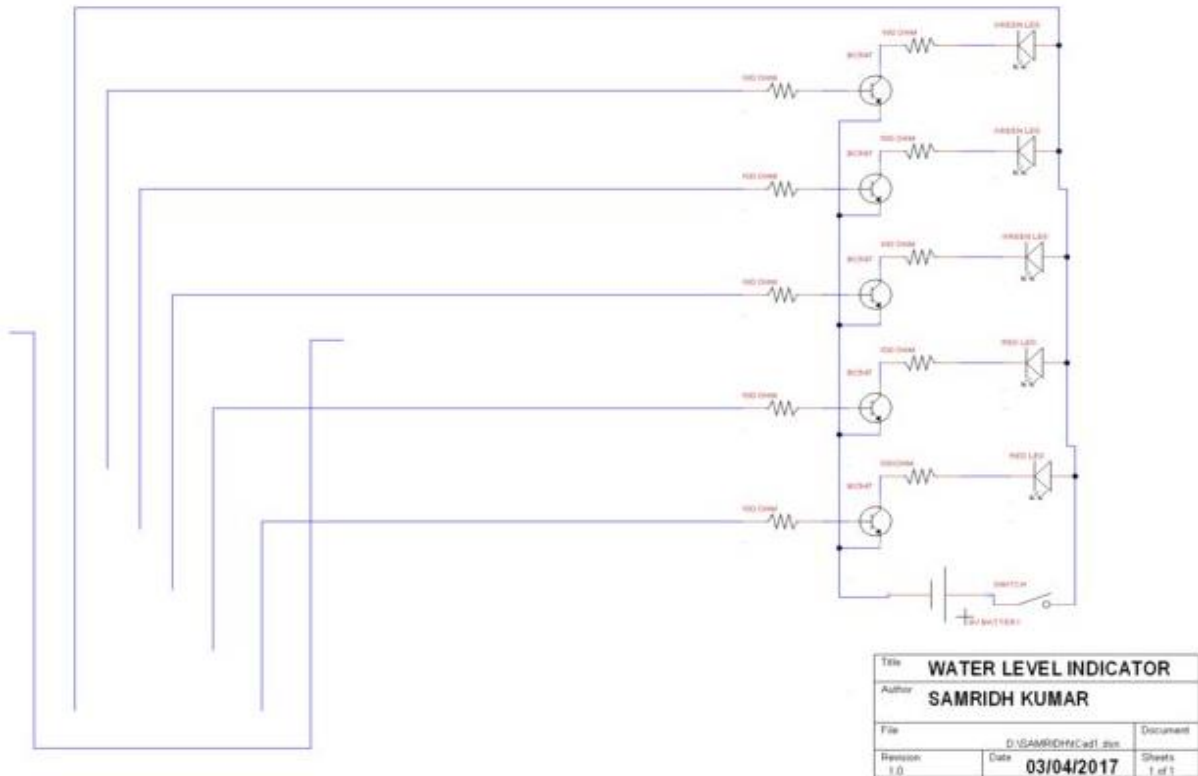
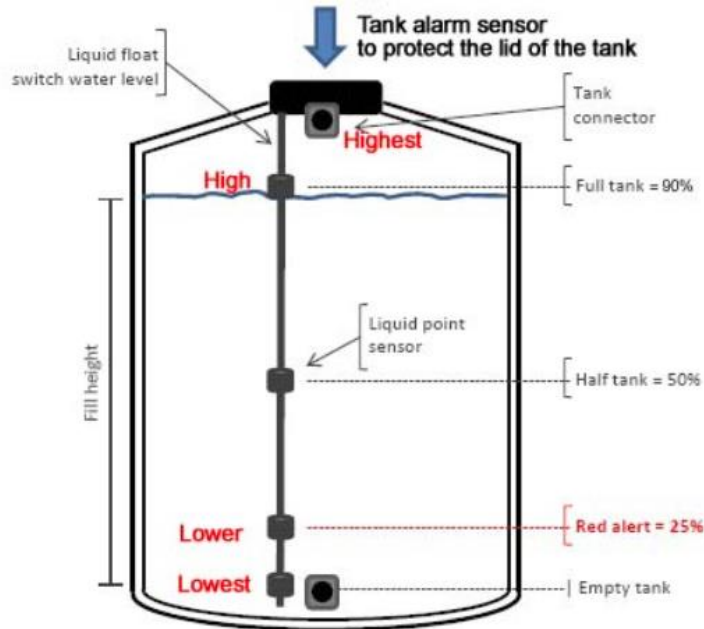

**Figure 31: Example of a water monitoring system circuit**

Similar to the method provided above, instead of letting a wire be submerged in water be the indicator, a possible solution could be to use float sensors at given levels to monitor the water levels. When the water level drops below a given float, a signal will be sent notifying the system of its current water level. If the system receives a signal that the number is below the drop line, the the pet feeder water dispenser would dispense water until the float line. This would take care of the possibility of a false reading of wet wires as previously mentioned. With sensors like the one seen in figure 8 costing on average 99 cents, this would meet the cost requirement of the automated pet feeder.



**Figure 32: All in one water level monitor by AquaPump.**



**Figure 33: Example of implementation of float sensor monitoring**

Another option of monitoring the water level would be to purchase an all in one packaged system that can be integrated with our existing interface. An example of this would be the all in one water level monitoring system that is provided by AquaPump. According to their website, the reading is reported back as an analog voltage ranging from 0V to 3V where 0V represents the sensor not being submerged, and 3V represents the maximum water level. [15] The automated pet feeder's microchip could take the given output voltage readings and alert the pet owner when a low voltage reading is read. The AquaPump system appears to provide an accurate reading of a given water level which is great for the automated pet feeder's application. On the other hand, the system is priced just at \$94.95 which drive our total construction cost really high. Unless the do it yourself method fails, this would not be a feasible option to utilize in the making of the automated pet feeder.

### 3.9 Food Reservoir Monitoring

The Automated Pet Feeder need to be able to monitor the amount of food that is being dispensed into the dry food reservoir in order to know how much food is available at all times. The requirements set for this portion of the design was to ensure the capability of monitoring the food levels that will allow the consumer to be aware of the reservoirs capacity at all times. This is important because the user would want to be notified when the reservoir is running low on food for the pet. If this feature were to fail, this could lead the pet not receiving the proper nutrition for an extended period of time. Some ways to accomplish this goal would be to either use a scale that would be placed in between the frame of the automated pet feeder and the reservoir itself. Another method would be to

use laser disturbance sensors to know when food is above or below a certain point [85].

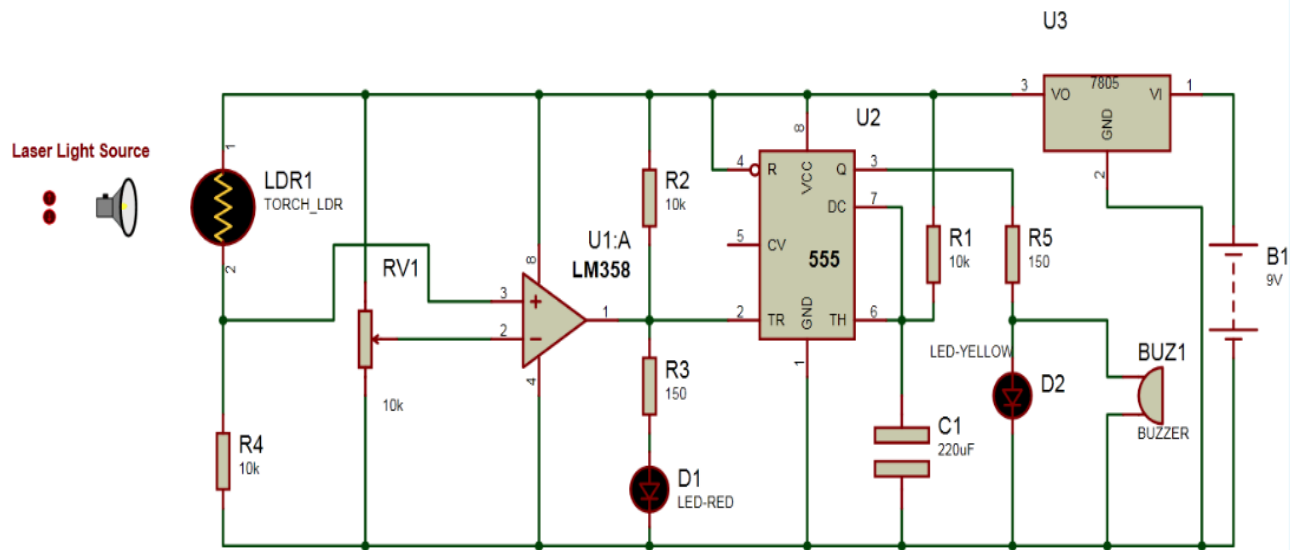

**Figure 34: Laser Security Alarm Circuit**

The first option that was examined was the use of a scale. In order for this option to work, we would need to design the frame of the automated pet feeder to hug the shape of the reservoir. Along the bottom of the reservoir, on the frame, we would install a similar scale to the scale used under the automated pet feeder's bowl. With this scale in place, the system could precisely monitor the amount of food in the reservoir based on the weight of the food in the reservoir. With this monitoring technique, the system would be able to alert the user when the automated pet feeder is running low on food. This alert would either come by a loud beep from the feeder and by an automated message sent to the user's mobile application.

The second option for monitoring the amount of food in the reservoir would be to use the technology of laser disturbance sensors. This can be fairly simple and cheap to implement with very minimal components. The way the laser sensor system works is by detecting when the line of sight of the laser and receiver. If there is something blocking or disturbing the line of sight between the laser and receiving sensor an alarm is sound. The automated feeder would use this method but in reverse. This means that an alert would only be sent to the system when the laser has full line of sight and contact with the receiver. In other words, if there is food blocking the line of sight of the laser sensor, this means that there is food above the allocated limit. Once the food level drops below the level of the sensor and the laser makes complete connection with the receiver an alert will be sent to the system and the user.

Considering the option for monitor the food levels in the dry food reservoir, it was decided that the best option to complete this requirement would be to utilize the laser disturbance sensors. The reason for this choice was based on price and ease of design. By using the scale option, this would put more strain on the design aspect and make the project

more difficult than needed. Implementing the laser design would require few components and very little money. It is for these reasons that the laser sensor was chosen.

### 3.10 Food and Water Bowls

There is much thought put into choosing the proper bowls that would be fitted into the automated pet feeder. With so many bowls made of numerous materials, further examination was needed to pick the best option possible. The three most common materials used for bowls for pets are plastic, ceramic, and stainless steel. It was decided that pet safety was the number one requirement when choosing the proper bowl for the automated pet feeder.

Plastic bowls are fairly popular in the pet market due to their flashy colors, designs and most of all their great prices. Plastic bowls tend to cost less than other material used for pet bowls. Deciding to use plastic would help to keep cost down when building the feeder especially with the use of a 3-D printer. Unfortunately, with plastic come many concerns. According to Barkthink.com some of the main concerns are “durability: for young and teething pups out there, a feeder bowl occasionally becomes another chew toy to be destroyed and eaten. All it takes is a few minutes without your supervision and these pieces of plastic can cause internal bleeding or intestinal blockage (and likely a huge vet bill). Bad bacteria: highly porous and easily scratched, plastic bowls are prone to developing cracks and crevices that can harbor unhealthy bacteria for your furry friend. Bisphenol A (BPA): I’m sure many of you are familiar with BPA by now. Every few years, there are news headlines regarding the hazards of plastics—most recently it has been about a chemical known as Bisphenol A, or BPA, that was found in baby products, sports bottles, and several other products used to hold edibles.” [12]



**Figure 35: Example of stainless steel bowls.**



It is for these reasons the automated pet feeder will not consist plastic made food or water bowls. The safety and pets' health need to remain of utmost importance when designing the automated pet feeder. Ceramic bowls make for excellent pet bowls. The only concern with ceramic is to ensure that no lead based glaze used in the making of the bowl. There are ceramic bowls marked with stamps ensuring the bowl could be used safely for food serving purposes. With the possibility of dropping or cracking the ceramic bowl when cleaning or transporting, ceramic would not be the best option for the automated pet feeder.

Stainless steel would be the best option for the automated pet feeder. This is due to stainless steel bowls being safe of bacterial, great price point, long product life span, and many other reasons. This stainless-steel option may not come in vibrant colors and pictures, but with peace of mind that the users pet will be harm free is worth the sacrifice. Stainless steel meets all the requirement of the pet feeder with it being safe for pets and the cost is at a reasonable price point.

## 3.11 Radio Frequency Identification

### 3.11.1 RFID Tags

When it came to select what type of technology would be ideal for authentication it came down to two options, RFID and Bluetooth technology. The way that Bluetooth technology work is through bonding and pairing. From experience, when pairing a Bluetooth compatible device, the process does not go as smoothly as possible. Even though the pairing process is required just once, the user is required to input a pin. This is an extra step that seems like extra work that the consumer must go through and might turn the customer off from buying the product. Even if the pairing process goes well, the bonding of the device isn't always successful the first time which can cause the consumer unwanted frustration. The other technology would be using RFID tags as a form of authentication. If the tag is in range, there is no additional work that needs to be done for setup and this is a crucial need that is wanted in the Automated Pet Feeder.

RFID stands for radio-frequency identification. With the use of electromagnetic fields, RFID's are used to identify and record the tags attached to objects. The tags contain electronically stored information which can be used to either enter restricted areas, set off detectors to prevent theft and is used for identification. RFID's operate under three types of frequencies, ultra-high frequency, high frequency and low frequency. The range for ultra-high frequency is about 300 MHz to 3GHz and have large waves that range from one meter to one decimeter[38]. High frequency has a frequency range of 3MHz to 30MHz and has a wavelength range that goes from ten to one hundred meters[39]. The range for low frequency goes from 30KHz to 300KHz and the wavelength range is from one kilometer to 10 kilometers[40]. There are two types of tags, passive and active tags. The way passive tags work is that they collect energy from a nearby RFID readers radio waves and it does not require a transmitter. The purpose of the RFID transmitter is to be able to take the signal received and pass it onto the device that needs to be communicated with. Passive RFID tags are versatile and can function under ultra-high frequency, high frequency and low frequency bands. These tags do not require an

external power source or a transmitter which makes them compact, affordable and they can be easily incorporated for any device. The active RFID tags need an external power source like a battery and a transmitter to function. These tags operate under ultra-high frequency bands and are mostly used for larger objects to track such as docking containers. Active tags can be read from about hundreds of meters from the RFID reader but, they are quite costly. [21] Since active tags require an external power source, they are more expensive and not as compact as the passive tags which is not ideal when it comes to the Automated Pet Feeder. The best choice the pet recognition would be using the passive RFID tags. Designing a pet collar using the passive tag is an excellent choice as an attachment to the pet's collar due to the size. The tag will be small which makes the collar comfortable for the pet and it will be a more aesthetically pleasing to look at for the consumer. Consumers are also looking new technologies that look pleasing and innovative at the same time.

After choosing the passive tag, research was done on what frequency should be used on the tags. There are two types of frequencies that were considered, high frequency and low frequency. The ultra-high frequency option was not even considered due to the cost and what applications it was used for. The high frequency tag comes in 13.56MHz and typically has a higher read range of up to 8 cm but is more sensitive to radio wave interference that may be due to surround liquids or metal [22]. Ideal applications for using high-frequency RFIDs would be for payment applications and data transfer. On the other hand, low frequency tags come in 125kHz and has a read range of up to 7cm but less susceptible to interference due liquids or metals which makes it ideal for livestock tracking. [23]. When came to choose which frequency would be suitable, the reading or scanning range was the most crucial point. Choosing the high frequency tag meant that it would have a higher read range but higher susceptibility to radio interference due to water. Choosing the low frequency tag meant having a lower read range but less chance for radio interference. Based on the design of the Automated Pet Feeder, the point of scanning would not be near any metal or water which decreases the chance of radio interference. Theoretically, the best option for the design would selecting the high frequency option due to its larger read range. With either option, the read ranges can be enhanced with the use of multiple RFID readers. This would create the opportunity to have multiple points of access so if one reader does not pick up the tag the first time then the other reader will be able to scan the tag as a backup. The readers would be placed strategically around the base of the pet feeder. This would technically eliminate the use of an antenna of an RFID antenna. Even with one RFID reader enhanced with an antenna, it still runs the risk of not reading the tag which means that the pet feeder will not open the door for the food. Both types of frequencies would accomplish the same task but using the high-frequency option reduces the cost of the pet feeder and have the highest read range when using two readers significantly.

In this section, the different options of low frequency RFID tags and high frequency RFID tags will be discussed in detail. The image below shows the three options for the high frequency and low frequency RFID tags.



**Figure 36: High Frequency RFID (top left), Low Frequency RFID (top right) NFC Tag (bottom)**

The Smart Card MF2 RFID IC Key Ring Tag is the first high-frequency RFID option represented in Figure below. These tags are economical and easily accessible to purchase. They have a round design which would be ideal to convert into an attachment for the pet collar. They can be easily enclosed in a plastic that can be colored to make it look more appealing. A cost-effective attribute using these fobs are that they are re-writable. If a mistake is made in the initial programming of the tag, it can simply be re-written. There are RFID tags that cannot be re-written, and it is an option that is not considered. The product must have room for change and using a tag that can only be written once does not allow for changes or updates if needed. Even the consumer can reprogram the tag in case there is an error that arises. These tags can be re-written over 100,000 according to its data sheet which can be seen in Figure I. This high-frequency tag is compatible with the Mifare RC522 RF IC Card Sensor Module which is one of the readers that will be discussed the RFID Reader section. The other high frequency alternative is the Adafruit 135.56MHz RFID/NFC White Tag. NFC stands for “Near Field Communication” and this type of tag also has a short-read range. NFC falls within the RFID family and a common application that it is used for is data exchange [41]. This NFC tag is a very secure application, but its excellent security is due to its short-read range which is only 2 inches. The tag is compatible with the PN532 NFC/RFID controller breakout board but due to its limited read range, it is not the best option between the two tags. The low frequency option is limited to one option. There is no NFC low frequency

version because NFC is only available in 35.56MHz. The low frequency tag option considered was the EM4100 125kHz RFID Door Control Keypad ID. This tag has a similar shape and design as its high frequency version. The main difference is that it operates at 125KHz.

Function	Specification
Size	30 * 40 * 3mm
Operating Frequency	13.56 MHz
Communication speed	106K Baud
Read and write distance	1 ~ 5cm
Read and write time	1 ~ 2ms
Endurance	> 100,000 times
Data Store	>10 years

**Figure 37: High Frequency RFID Tag Specifications**

For either option considered, multiple RFID readers are still needed to expand the read detection range for the RFID tags. By having more than one scanner point where the tag can be read, the chances that the tag will be read goes up as the dog approaches the pet feeder when it is time to eat. This is more like a backup plan in case the first scanner fails to read the tag. The tag that will be chosen is the high frequency Smart Card MF2 RFID IC Key Ring Tag due its higher read range and its design versatility. Its specifications are shown below.

### **3.11.2 RFID Reader**

Just like there are high and low frequency RFID tags, there are high and low frequency RFID readers. These readers come in different designs, sizes and cost. There are fixed, handheld, USB and integrated circuit readers that are available on the market. When researching fixed readers, it was concluded that they were extremely overpriced and were used for large scale due to its high read range and the applications that were used for were beyond the allowed budget allowed for the product. Some readers come with the option to perform read/write functions which give the user control on how many time a tag can be re-written. Another way to make authentication secure, some readers come with a biometric scanner. A reader with those extra features drives up the cost and for this product, it would be an excessive and unnecessary. The RFID readers that will be discussed in the section are the integrated circuit reader, USB reader and the NFC reader. For the Automated Pet Feeder, two RFID readers are needed and will be used to increase the scanning area. By increasing the scanning area, this will increase the chance that the RFID tag is will scanned by either reader. It is crucial the tag gets read so that the food door will open so that the pet can access the food. There are two models of RFID

readers that will be incorporated in the Automated Pet Feeder, one reader will be integrated in the PCB board and the other will be in the form of a USB

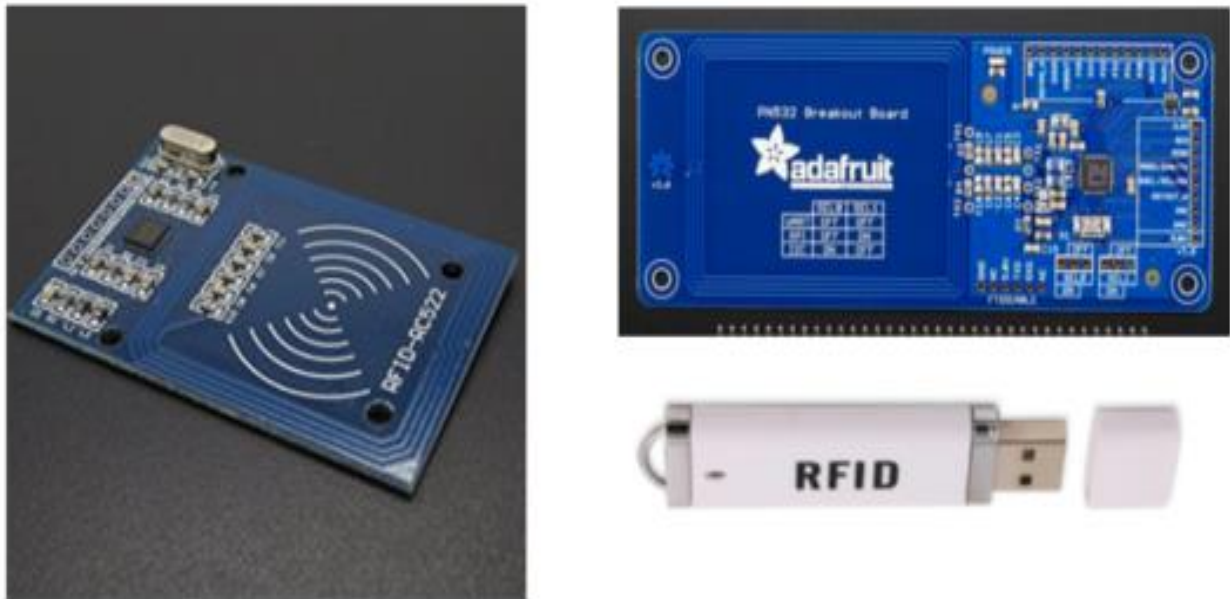

**Figure 38: High Frequency Scanner (left), NFC Scanner(top right) and High Frequency USB Reader (bottom left)**

Starting with high frequency readers, there will be three models to be discussed, two RFID only readers and one NFC reader. Both RFID only readers are compatible the 13.56MHz Smart Card MF2 RFID IC Key Ring Tags mentioned in the previous section. The first reader is the Mifare RFID-RC522c IC Card Reader Module. The PN532 NFC/RFID controller breakout board is compatible with the 13.56MHz RFID/NFC White Tag. Below is a comparison of all three high frequency readers along with specifications of each one.

The first reader is the MF RC522 module that is applied to the integrated read and write chip. The convenient feature that this integrated circuit has is that can be incorporated into the final PCB design. The chip also supports a contactless scan to the tags. Contactless feature is crucial since the pet will not actually place the tag right onto the scanner. The integrated circuit requires low-voltage and is available at a low-cost. It is small 40mmx60mm module which will facilitate incorporating it into the external enclosure with ease as referenced above. The contactless feature also will help that the pet with the RFID collar does not need to be directly on top of the reader to access its food and can detect an unauthorized tag if it is in close proximity of the reader [24]. The reader needs to be able to authenticate the correct tag and if it scans an unauthorized tag, the door for the food will close. The will prevent the unauthorized pet from eating and read time from the scanner is also an important factor. The second RFID reader that will be considered is the Chafon13.56MHZ Mini USB HF RFID Mifare IC Card Reader which will be placed additionally in lieu of an RFID antenna. If the second scanner is strategically placed, it will ensure that the tag will get read. Since this reader is in the shape of a USB

it will be ideal to this the reader as a beacon, thus spreading out the read range since it is also a contactless reader. It is a high performance, lower price 13.56MHz RFID reader which has read range distance of up to 12cm as referenced in Figure 35 above [25]. The last option for the high- frequency reader is the PN532 NFC/RFID controller breakout board. This is an unlikely option due to its extremely high price for the purpose of the product. Not only this is the most expensive option the tag has to be in less than a 2-inch range which is not ideal since the other two readers have the advantage of a longer range and they are much more affordable. The goal is to have reliable and functional parts that are affordable to obtain profit and to be able to compete in the market for pet feeders.

Looking the low frequency options, it was narrowed down to two options. There is no such technology as low frequency NFC reader since, NFC is a high frequency technology only. Below is a comparison between the two low frequency options along with its specifications. Now the two low frequency alternatives that are compatible with EM4100 125kHz RFID Door Control Keypad ID will be discussed in this section. Low frequency radio signals are ideally used for long distance AM radio broadcasting in Europe and in Asia[X3]. The first reader is the Chafon Mini USB RFID 125kHz ID EM Proximity Card Reader. This reader is similar to the Chafon high-frequency reader, but the only difference is the price and the frequency range. The second low frequency reader would be the Sparkfun RFID Reader ID-12LA (125kHz). This reader comes with a built-in antenna and gives of a range of 12cm -18cm specified in Figure 1 above. Another RFID reader would still need to be used and the downside to that it is not as affordable as the high frequency option [26].

All though the range on the low frequency readers are about 5cm more than the high frequency readers, just utilizing one low frequency reader would not ensure the RFID tag would be scanned always when the pet would want to access the food or if an unauthorized tag is scanned. An advantage that needs to be considered when choosing between a low frequency and high frequency reader the data read rate. The RFID scanner operates at a slower read rate. That can become problematic since our pet feeder relies on a quick read of unauthenticated RFID tags. Using a high frequency device will ensure faster data read rates [23]. Since multiple RFID readers are needed for a better-read range, the product would end up being more expensive and it would force the price of the final product up which is not desirable.



**Figure 39: Low Frequency Scanner (left) and Low Frequency USB Reader (right)**

In the end two RFID readers need to be utilized and they both need to be placed in strategic locations around the base of the Automated Pet Feeder. It needs to be able to read the RFID tag that is hanging from the pet's collar for authentication purposes. Only one pet can be assigned to the Automated Pet Feeder and that will be done through the unique RFID tag that will be assigned to the pet. The reader will be programmed to only recognize that unique tag and then the Pet Feeder will open the door to allow the pet to eat. If the Automated Pet Feeder scans an RFID tag that is not recognized, the door will not open. In the scenario where the appropriate pet is eating and the pet with a tag that cannot be authenticated attempts to eat the food by getting too close to the feeder, the door will close over the food. There will be a time out period and once that period is over, the reader will attempt to scan the correct tag. If the correct tag is recognized, the process will repeat again, and all of this is to prevent unwanted stealing of the pet's food. The two RFID readers that were chosen are both high frequency the Mifare RFID-RC522c IC Card Reader Module and the Chafon 13.56MHz Mini USB HF RFID Mifare IC Card Reader and their specifications are shown below.

Function	Specifications
Operating current	13-26mA/DC 3.3V
Idle current	10-13mA/DC 3.3V
Sleep current	<80uA
Peak current	<30mA
Operating Frequency	13.56MHz
Supported card types	mifare1 S50, mifare1 S70 MIFARE
Size	40mm×60mm
Environmental Operating temperature	-20-80 degrees Celsius
Environmental Storage Temperature	-40-85 degrees Celsius

**Figure 40: Mifare RFID-RC522c IC Card Reader Module Specifications**

Name	HF Reader& writer
Dimension	74X19X6mm
Standard	ISO 14443A
Support	MIFARE® Classic 1K; MIFARE® Classic 4K ;MIFARE® UltraLight;
Frequency	<b>13.56MHz</b>
speed	106kbit/s
Baud Rate	9600 bit/s
Power Supply	+5V DC
Consumed Current	< 80Ma
Operating Distance	50--70mm
Interface	USB
Status Indication	1pc LED
Service Temperature	-10°C ~ +70°C
Store Temperature	-20°C ~ +80°C

**Figure 41: Chafon 13.56MHz USB HF RFID Mifare IC Card Reader Specifications**

## 3.12 Camera

To be in the line with other competing products, the Automated Pet Feeder has a camera feature incorporated so the user can take a snapshot of their pet enjoying their food. There is a need in the market for the owners to have updates of their pet. By having the camera feature added, it gives the owner a sense of closeness to their pet and ensuring them that they are eating, or it is just an opportunity to have a glance of the pet when they are missed. There are multiple options when it came to select an ideal camera. It is essential that the camera is affordable and can take good quality pictures in the day time. Night time use of the camera is very unlikely because the pet will be sleeping at that time. There is several It also must be incorporated in the PCB design which means it must be compact and have a way to extend to it can be placed appropriately on the pet feeder enclosure. Ideally the camera should have a flex cable so that it can have more room for designing the final PCB board. The camera peripheral will be situated in 3D printed enclosure at about the pet's eye level for a clear view. Using the Automated Pet Feeder mobile application, the user can save the picture directly to their phone or send it another recipient.

In this section, five camera options will be discussed that are available and compatible for the Raspberry Pi Boards. They will be divided into two separate megapixel sections. Below shows a comparison of the three 5MP options available along with its specifications.

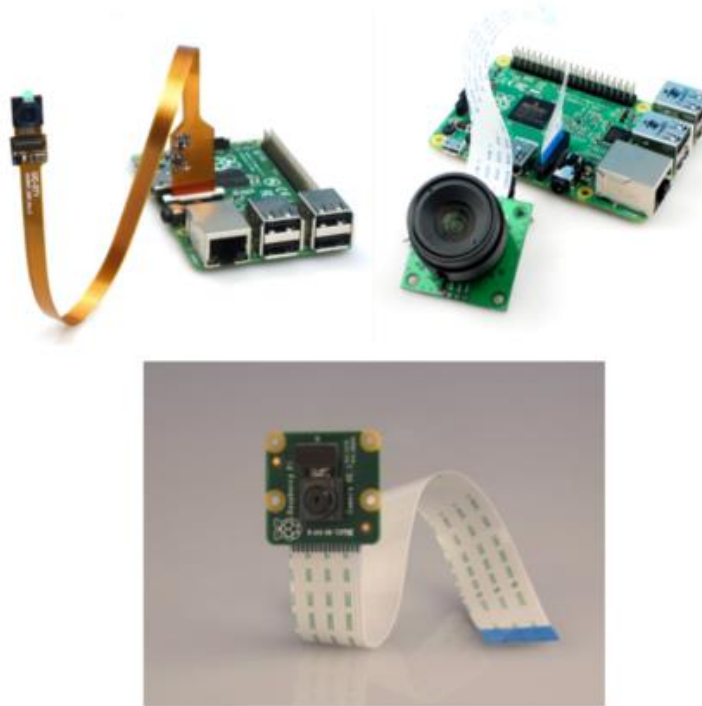

**Figure 42: Spy Camera(right), Pi Camera Module (bottom) and Rev.C (right)**



Starting with the Raspberry Pi Camera Module 5MP REV 1.3, this camera board is small and uses a ribbon cable to attach to the board. The interface used is the Camera Serial Interface which allows camera and the processor to communicate between each other. The CSI interface which is ideal for high data rate flow and has the capability a transferring pixel data back to its processor. All the data transfer is done through the ribbon cable that connects the lens peripheral to the processor [42]. The camera module comes with the OV5647 5MP sensor that has a maximum pixel range of 2592 x 1944, which will deliver quality images to the user [27]. The pixel performance of the OV5647 allows 720p and 1080p HD videos at 30fps and can support live streaming option if necessary [28]. The second model for the 5MP camera is the Spy Camera for the Raspberry Pi. This model has a convenient flex cable that is about 6mm wide which makes it perfect to place in obscure positions which would make the design for the PCB less complex. This option is twice the price of the other camera, but the only benefit is the length of the flex cable and how narrow it is.

The third camera is the Rev.C OV5647 Camera which specializes in optical performance and captures higher quality images. The specifications are the mostly for the same for all three cameras except that the Rev.C OV5647 camera supports FREX/STROBE feature. This feature optimizes the image by using the multi-camera synchronize capture[48]. This camera also has the same CSI interface seen in the other cameras. Moving on to the camera with the higher 8MP resolution, there is one option as shown in the Figure below.



**Figure 43: Sony IMX219 Camera**

The first model discussed is the 8MP Sony IMX219 Camera. It comes with a M12 camera lens. This type of lens is mostly used for surveillance and webcams. This type of lens mount can be direct mounted on to PCB board which make is versatile to use for unique projects and it is also known as a “board lens” due to that characteristic [44]. The Sony IMX219 module can take images at 3280 x 2464 pixels which produces a much clear image and if necessary supports up to 1080p video at 30fps. It also offers field of view and depth of vision plus the option of night vision due to the IR cut filter [43]. Field of view

is the view of a scene at any given moment to the human eye and in the camera, it is the area of inspection captured through the camera's lens. The resolution of the image is impacted by the size of the field of view and the size of the camera lens. The larger the lens is the wider the field of view will be [45]. Depth of field is the focus between the farthest and nearest object. What determines the quality of the depth of field is focal length and how far the object picture is been taken. The quality decreases if the lens is closer to the object, or if the lens has a greater focal length but its focal length is shorter than the quality of the depth of field [46]. It also comes equipped with a motorized IR cut filter which is ideal for pictures taken in low light which is also used for night vision pictures. During the day when there is light, there is a filter that covers the sensor, so color images can be taken and when it gets dark, the filter is lifted, and it allows brighter pictures to be seen and taken [47]. This camera has the same CSI interface, which allows very fast data rate transfer between the processor and the camera.

The camera that suits the needs of the Automated Pet Feeder does not require a camera with high quality images. The images that would be taken are when the pet is eating and during the day which eliminates the need for having a camera that supports night vision. The field of view or the depth of field does not need to be at a high quality since the photo subject will be at somewhat close range. The camera device that was chosen is the Raspberry Pi Camera Module 5MP REV 1.3 because it was the most economical choice that delivered 1080p mode and 5MP quality images. It serves the same purpose as the other cameras and it drives the cost of the product down which will make it more affordable for the consumer to purchase while having the opportunity to see their pet eat.

**Specifications**

<b>Image Sensor</b>	Sony IMX 219 PQ CMOS image sensor in a fixed-focus module.
<b>Resolution</b>	8-megapixel
<b>Still picture resolution</b>	3280 x 2464
<b>Max image transfer rate</b>	1080p: 30fps (encode and decode) 720p: 60fps
<b>Connection to Raspberry Pi</b>	15-pin ribbon cable, to the dedicated 15-pin MIPI Camera Serial Interface (CSI-2).
<b>Image control functions</b>	Automatic exposure control Automatic white balance Automatic band filter Automatic 50/60 Hz luminance detection Automatic black level calibration
<b>Temp range</b>	Operating: -20° to 60° Stable image: -20° to 60°
<b>Lens size</b>	1/4"
<b>Dimensions</b>	23.86 x 25 x 9mm
<b>Weight</b>	3g

**Figure 44: Raspberry Pi Camera Module 5MP REV 1.3**

## 3.13 Scale

When it comes to portion control, the consumer responsible for determining how much food the pet should eat. They would have to take a measuring cup and measure exactly the amount of food necessary. Sometimes the task can become tedious and then they become lenient on how much food should be dispensed. The Automated Pet Feeder takes the guesswork out of much food should be dispensed. The owner now does not need to dirty another measuring cup or worry about overfeeding or even underfeeding their pet. Using the pet feeder app, the user will be able to set up a profile for their pet. They will be able to input their weight and either manually enter the amount of food they want dispensed or set up their food with a suggested serving size depending on the weight of their pet and the brand of food. If the brand of food is not listed, the owner has the option to create a food entry and set up the desired serving size for their pet. All the preset food brands will be stored in a database which will hold queries such as, name of the food, weight of the pet, and recommended serving size for the weight range. Either option that the owner chooses it all comes down to the weight of the food selected. That weight will be determined using a weight scale. The scale is made up of two components, a load cell that varies in weight limits and the ADC Converter which takes the signal and converts it to a human readable value. The food scale will be incorporated into the PCB design and it will measure out how much food the pet needs and the pet feeder will stop dispensing until the desired amount of food. The amount of food is determined by the pet profile that will be set in in the Automated Pet Feeder App. In case the owner has no access to network to operate the mobile application, there is a failsafe system. There will be an actual button that the owner can press, and the pet feeder will still measure the correct amount of food based on the previous amount dispensed. The previous amount will always be accessible in case there is a network outage. The emphasis of a healthy diet for the pet will depend on the functionality of the scale and how well it performs making it crucial to select the correct components. In this section, the two components that will be discussed about the food scale are the HX711 ADC Converter Breakout Module and the load cell.

### 3.13.1 Load Cell

Starting with the load cells, there are three different type of load cells available. A load cell is a physical element or also known as a transducer that can translate force into an electrical signal from which we can obtain a value and store in a database to keep track of the amount of food being consumed over time. “Before load cells became the standard for industrial weighing, mechanical levers were used. Mechanical scales weighed everything from small items like pills to railroad cars and were weigh so accurately and they were very reliable when they were properly calibrated.” That all changed when Sir Charles Wheatstone created a bridge circuit that was able to measure electrical resistances [51]. There are three types of load cells that can obtain readings when measuring weight. Below shows a comparison between the different load cells.

First there is the hydraulic load cell. “Hydraulic load cells use a conventional piston and cylinder layout to demonstrate a change in pressure by the movement of the piston and a diaphragm arrangement which produces a change in the pressure on a Bourdon tube

connected with the load cells as shown above.” The reading is obtained from the pressure gauge [29]. To obtain an accurate reading from this cell, it is important to make sure that the initial force being applied is central. Any slight error in the incorporation of this cell that can lead to side forces or unwanted bending and torque can give off erroneous values which can be fatal to a company. This load cell is used in large scale applications such as seeing much the lift load of a machine is, using to test to force applied on clamping vices, brake testers, test tension exerted on construction ropes and belts and even measure the level of silos. These are all applications that need 100% accuracy to prevent any possible accident [48].

The next type of load cell is the pneumatic load cell. Pneumatic load cells utilize air pressure and is used at one end of the barrel then pressure is released through a nozzle placed at the bottom of the load cell. A pressure gauge is located at the bottom of the load cell as shown in the figure below [29]. This load cell is used in smaller scale applications, not like the hydraulic load cell which is used on a large scale. This type of cell is mainly used when a controlled and clean environment is in place. These load cell is not affected by temperature which means the reading are extremely accurate and is ideal for laboratories. If the barrel were to burst, there are no fluids that would leak and cause site contamination. The hydraulic load cell would not be ideal since it has liquid in its diaphragm. But, it does have its disadvantages since it takes a while to obtain a reading and need access to dry controlled air or nitrogen [51].

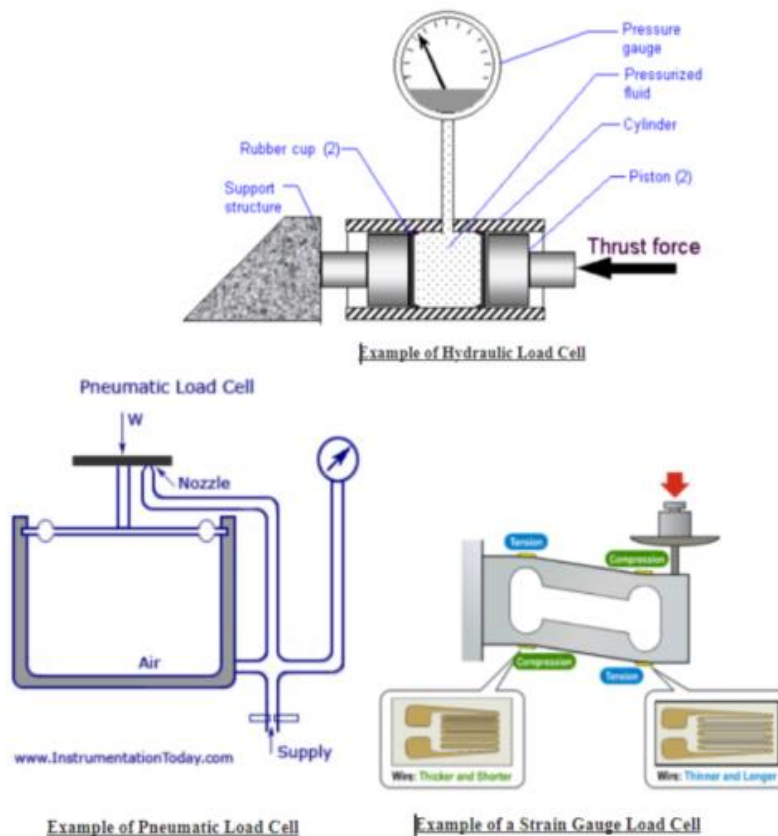

**Figure 45: Examples of Different Load Cells**

The last type of load cell is the Strain Gauge Load cell. When force is applied to the cell the way weight is measured is through bending distortion on two tension and compression gauges and it becomes an electrical signal. The load cells are placed in between two plates and when direct force is applied, and the surface will be deformed. [29]. These load cells are susceptible to changes in the environment and can have a plus or minus 5% error due to uneven surface, temperature, vibrations, mechanical and electrical disturbances but for the most part they do provide the accuracy needed [52]. This is the most common load cell found in many household applications such as postage scales, body weight scales and food weight scales used in the kitchen. The Strain gauge load cell come in different sensitivities and weight capacities and activates when direct force is applied.

Using the hydraulic load cell for the Automated Pet Feeder would be not only excessive due to its application but very expensive for what the budgets requires. Even though the pneumatic load cell can be used for the product application it would still force the budget to go over and it is not necessary to have sterile conditions, since the pet feeder will not be in a controlled environment. The strain gauge load cell would be the most economical and realistic choice to incorporate into the PCB design. Not only would it put us within budget, the base for the load cell can be custom made to support the pet dish when a reading is needed. It is necessary to find components that can be easily incorporated into the PCB design and that will fit in the 3-D printed enclosure for the pet feeder. After thorough research in deciding which load will be used for the product, finding the best sensitivity for the strain gauge load cell is the next step. There are multiple weight capacities such as 1KG, 5KG, 10KG and even up to 50KG.

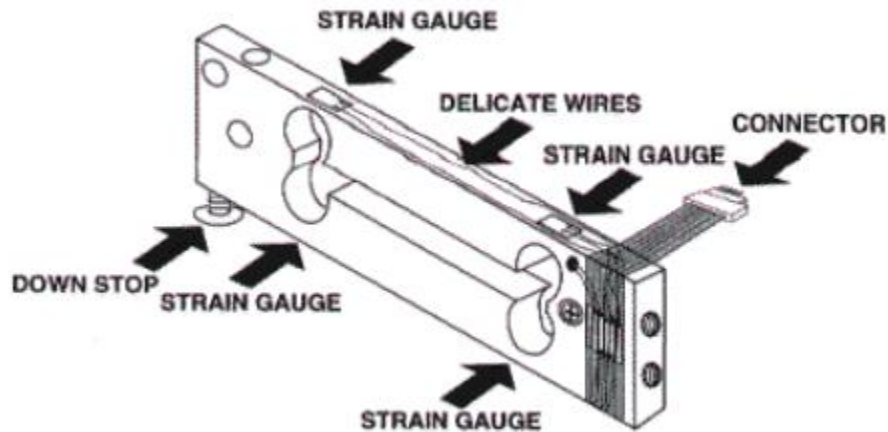

**Figure 46: Breakdown of Strain Gauge Load Cell**

Strain gauge load cell come in different sensitivities and weight capacities and activates then direct force is applied. There were two options available for the load cells, one for 5KG and the other was 10KG. The Automated Pet Feeder has the maximum capacity of serving 2 cups of pet food which is the equivalent of about .3KG. Choosing the 10KG load cell may not be as sensitive and not measure with the precision necessary. Using

the 10KG load cell runs the risk that it might not even register on the .3KG weight of food. The 5KG load cell will give out a more accurate reading with less room for error. Calculating the weight is crucial for when the pet is eating from the bowl. When the pet is eating from the bowl, extra force is being applied to the bowl. If the pet is applying direct pressure after the food was dispensed, the pet feeder should not dispense anymore food. Also if there is food in the bowl leftover, the pet feeder should not dispense another full serving size of food. The pet feeder will dispense the remaining portion to make a serving size. This feature is meant to prevent the pet from overeating and prevent the risk of food being wasted. For the Automated Pet Feeder, a 5KG load cell will be the ideal component because it will be able to detect accurately the .3KGs of pet food and any pressure that the pet applies the weight directly. The next component that makes up the food scale will be choosing a module that will convert the resistive electrical signals into values that can be interpreted and that can be used. There are two options to choose from and below shows the comparison between the modules along with their specifications.

### 3.13.2 Analog to Digital Converter

The second component to the food scale is the HX711 ADC Converter Breakout Module which is also known as the Load Cell Amplifier. This component will be able to convert the signals processed from the force to the cell and return values that can be stored in a database to keep track of how much food has been consumed. “Load Cell Amplifier is a small breakout board for the HX711 IC that allows you to easily read load cells to measure weight. By connecting the amplifier to your microcontroller, changes in the resistance of the load cell, and with some calibration the system will be able to get very accurate weight measurements.” [30]

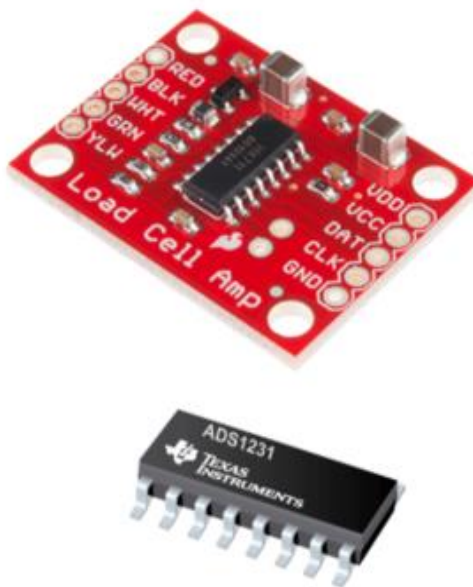

**Figure 47: HX711 ADC Converter Breakout Module**

The first module is the Sparkfun HX711 ADC Converter Breakout Module. ADC stand for Analog-to-Digital Converter. An ADC takes an analog voltage from a pin and converts it into a human readable digital number [53]. There is an input channel that is specifically designed to interact with the bridge sensor's output which where the load cell will connect to. The module is powered by the microcontroller, so it depends on that power supply. If the output data will be given in 2's complement and customized code will be written to convert that data into values that can be interpreted [54]. The second ADC module is the TI ADS1231 Low-noise 24-Bit Analog-to-Digital Converter which is similarly equivalent to the specifications of the HX711. The main difference will be the price of the module and that it is only compatible with the MSP430. After careful consideration, the HX711 is the more economical and versatile option that can be easily placed in the PCB design. The specification for the ADC converter is shown in image below.

- Operation Voltage: 2.7V–5V
- Operation Current: < 1.5mA
- Selectable 10SPS or 80SPS output data rate
- Simultaneous 50 and 60Hz supply rejection

**Figure 48: HX711 ADC Converter Breakout Module Specifications**

### 3.13.3 Proximity Sensors

A key factor of safety that will be incorporated into the Automated Pet Feeder is making sure that the door does not close on the pet while it is eating. If in any way the pet become injured due to the feeder that can turn into a liability for the project and the members on it. Proximity sensors would be used to prevent any unwanted injuries. The sensor essentially would detect the presence of an object without any physical contact. Since the pet is not intentionally looking for the sensors this is the perfect solution on maintaining the food door open. The sensor would work in conjunction with the micro controller and PCB design which would fit in the custom-made enclosure.

There are multiple types of sensors: capacitive, inductive, magnetic, radar, sonar and ultrasonic sensor. With capacitive sensing there two types of configurations: mutual capacitance and self-capacitance. The mutual capacitance configuration is made up of two terminals that operate as emitting and receiving electrodes. In other words, there is an object that changes the mutual coupling between the electrodes. This configuration is found in displays that have touch screen capability. The self-capacitance configuration has one terminal of the sensing capacitor connected to ground and the object loads the sensor and increases parasitic capacitance connected to that ground. With either configuration it senses the object's position on the screen due to the change of capacitance [62]. A finger is more than enough to cause a change in capacitance, but it is not discharging the capacitor because the finger is insulated by usually a PCB mask and plastic that separate the electronics from outside elements. The reason the capacitance alters with a finger is due its conductive and dielectric properties. Since the capacitor electric fields extends reaches out around its surroundings, the finger does not have to be exactly between the conductive plates to changes its dielectric characteristics.

The finger is also an excellent conductor since the body is like a virtual because it can take in electric charge and acts like an additional conductive plate of the capacitor [61].

The next type of sensor is called inductive proximity sensing and functions without any contact. This is primarily used detecting metal objects and can be found airport metal detectors for example. The range varies depending on the metal, if the metal is ferrous the range can be wider. On the other hand, if the metal is non-ferrous such as aluminum and copper, detection range can drastically go down about 60 percent. There is an induction loop in the sensor and a magnetic field is created through electric current. Depending of the type of material used for induction the presence of metal increases the current flowing through that induction loop. That change is triggered and sent to the circuitry which signals another device that there is metal present. This type of sensor can be incorporated into a PCB design if needed [63].

Magnetic proximity sensors are another type of non-contact device that can detect if a magnet is close by. When a magnet is detected and within range, the switching process is triggered. The switch is usually a reed switch, which is a device that has two ferromagnetic contact blades. When a magnet is within range the contacts close when they are attracted to each other in a glass tube [64]. Another type of contactless proximity sensor is a sonar proximity sensor. It has the ability to detect objects from short to long range distances. The sensor emits ultrasound waves and if it hits an object, the echo gets converted into an electric signal that can interpret how far away an object is. This sensor is versatile because it can practically detect any object whether it be solid or even liquid which is practical for the Automated Pet Feeder [65].

The last type of proximity sensor is the ultrasonic proximity sensor. These sensors ultrasonic waves that are either reflected or received to detect if an object is close by. The signal that it emits is a high frequency sound wave that cannot be heard. It has two configurations to detect the presence of an object. First configuration of the sensor is the diffuse or reflective sensors. Enclosed in the same housing they have the transmitter and the receiver and when an object is within range, the ultrasonic waves go back to the sensor. The other type of configuration is the opposed or thru-beam sensors that the transmitter and the receiver are not within the same housing. The receiver faces the transmitter and when it detects an object nearby the signal is blocked and then the trigger is activated. This type of sensor can also be used to detect an array of different materials and but if the object is too close, it might not be able to detect it [66].

After through research, an ultrasonic proximity sensor would be the best fit for the Automated Pet Feeder. The pet does not need to be in close contact with the sensor and the collar does not need any extra accessories such as metal or a magnet for detection. It could be possibly hazardous including a piece of metal or a magnet to the collar because there could be a possibility that it accidentally falls, and the pet can ingest it, which can be a severe liability. There are three options that were considered when it came to functionality and price are: The Ultrasonic Sensor – HC-SR04, Sparkfun RGB and Gesture Sensor – APDS-9960 and the Ultrasonic Range Finder – HRLV- MaxSonar-EZ4.



The Ultrasonic Sensor – HC-SR04 can have a range of 2cm to 400cm of contactless measurements. The device sends eight 40kHz waves at the speed of sound and waits to detect if a pulse wave is received in the echo pin. The echo pin returns the time in microsecond that it took the sound wave to travel. It has four pins: the echo, trigger, ground and VCC which makes the device compact and will not take up much space on the microcontroller. It operates on 5V with a working current of .015A [67].

The next sensor is the Sparkfun RGB and Gesture Sensor – APDS – 9960. The device offers proximity detection, color detection and touchless gesture sensing. The unique attribute of this device is the gesture detection because it used four photodiodes to sense IR energy and convert it into physical motion information to a human readable value. The gestures can be stored on the device and can be calibrated to unique movements. Color detection is measured by the intensity of red, green, blue and clear light. It can sense ambient light and sense color which allows the device to calculate color temperature and control display back light. The proximity detection works in a slightly different way from the device above. It obtains the objects distance by the reflected IR energy of the photodiodes. It uses a I2C- bus fast protocol which transmit data up to 400kHz. It has a detection range of 10cm to 20 cm and uses an operating voltage of 3.3V which is lower than the device above. The device is slightly larger and may not be easily incorporated into the PCB design of the Automated Pet Feeder [68].

The last sensor is the Ultrasonic Range Finder – HRLV – MaxSonar – EZ4 and had a larger detection range of 30cm to 5 meters. This device provides high accuracy but is meant for indoor use. It is reported that most sensors when they detect large objects, it reads to distance as closer than it actually is and when the object is smaller, it reads it as farther than it actually is. With this device, the sensor correctly compensates for the object's different sizes. The downfall to this sensor is that when it detects objects closer than 30cm, the minimum reading it will give of is 30cm and is not reliable for the Automated Pet Feeder's purposes. This device uses an operating voltage of 2.2V -5.5V and a current draw of 2.5mA at 3.3V and 3.1mA at 5.5V.



**Figure 49: Ultrasonic Range Finder (bottom), HC-SR04 (top right), Gesture Sensor and RGB Finder (top left)**

After careful consideration of these components, the Automated Pet Feeder would benefit from using the Ultrasonic Sensor – HC-SR04. It is an economical option and it uses low operational voltage which will benefit the owner when purchasing The Automated Pet Feeder. The device is small enough that it can be easily incorporated in the PCB design and in the custom-made housing of the pet feeder and will blend in as a whole. A close detection range is needed to avoid any blind spot that may occur. If the pet is in the blind spot while eating, the door will not remain open which can be a liability if the pet is injured in anyway. The detection range on the HC-SR04 is ideal since the pet will be between 2cm to 400cm and it will not run the risk of being in a blind spot. The specifications of the chosen sensor are shown below. Since this device has a relatively low operational voltage it can power itself from the microcontroller.

<b>Working Voltage</b>	<b>DC 5 V</b>
<b>Working Current</b>	<b>15mA</b>
<b>Working Frequency</b>	<b>40Hz</b>
<b>Max Range</b>	<b>4m</b>
<b>Min Range</b>	<b>2cm</b>
<b>Measuring Angle</b>	<b>15 degree</b>
<b>Trigger Input Signal</b>	<b>10uS TTL pulse</b>
<b>Echo Output Signal</b>	<b>Input TTL level signal and the range in proportion</b>
<b>Dimension</b>	<b>45*20*15mm</b>

**Figure 50: Specifications of HC-SR04**

### 3.14 Parts Selection

After several weeks of thorough part selection research, the parts that were selected will ultimately be chosen for the final design of the Automated Pet Feeder. The factors that were considered critical were: cost, low power consumption, size, versatility and range detection. Below is a picture of all the critical points

Automated Pet Feeder

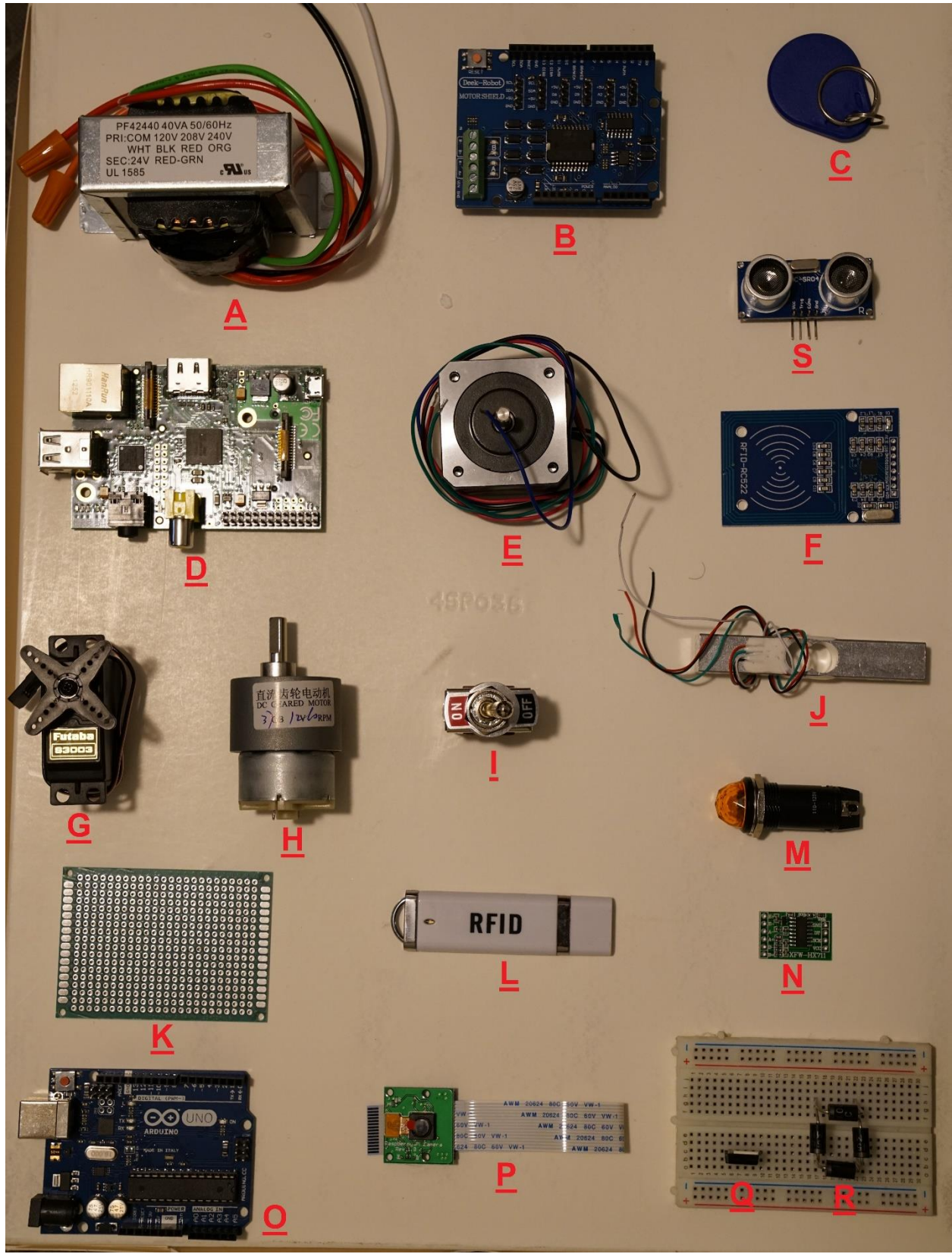

Figure 51: Final Parts Selection

<b>A</b>	Transformer	<b>K</b>	Double Sided PCB
<b>B</b>	Motor Shield	<b>L</b>	RFID Reader
<b>C</b>	RFID Tag	<b>M</b>	Neon Lamp
<b>D</b>	Raspberry Pi	<b>N</b>	HX711 ADC Converter
<b>E</b>	Nema 17 Stepper Motor	<b>O</b>	Arduino Uno
<b>F</b>	RFID Reader	<b>P</b>	Pi Camera Module
<b>G</b>	Servo Motor	<b>Q</b>	Voltage Regulator
<b>H</b>	DC Motor	<b>R</b>	Bridge Rectifier
<b>I</b>	Stationary Switch	<b>S</b>	Ultrasonic Proximity Sensor
<b>J</b>	Load Cell		

**Table 5: Names of Final Part Selection**

## 3.15 Software

### 3.15.1 Operating Systems

An operating system is a software system that needs to be able to handle the hardware and software resources for the intended device. There is the Linux based OS such as Raspbian, and Pidora and the ARM architecture RISC OS Pi are available for the Raspberry Pi.

### 3.15.2 Raspbian

Raspbian is the Debian-based operating system for the Raspberry Pi. This operating system includes basic program and utilities. Raspbian emulates a simple desktop computer which is a good choice for people who are not familiar with the Linux environment. The terminal will be the main point on how to update and install new packages on this OS which makes it customizable to the purpose of the project. Since this OS is closely related to Debian, the Raspbian is very well documented and security patching is always updated. Whenever there is a security patch released for Debian, that same patch can be applied for Raspbian. This is one of the few open source operating systems that update their security. Most of the time the problem with open source software is that there is not much support since it is not funded by a large company or it depends on crowdsourcing for fixing bugs or releasing updates which means it is not a steady schedule. Also, since the Raspberry Pi is not a high-power device, some programs may run a bit slower but for the product's needs, the terminal will be used the majority of the time [51].

### 3.15.3 Pidora

Pidora is the Fedora based operating system. For the Raspberry Pi. It uses the ARMv6 architecture which promotes better speeds. Similarly to Raspbian the terminal would be mostly used when the OS is installed to install languages needed for the application.

### 3.15.4 RISC OS Pi

RISC OS Pi is an operating system that is designed for ARM processor. It is very user friendly and provides a stable environment for users. What is interesting about the OS is that it is installed on the ROM, making it super secure where viruses cannot infect it. This OS is ideal for embedded application due to its high performance and ROM [52]. After thorough research, the Raspbian OS is the most suitable choice for the automated pet feeder. Below are the specifications for the operating system of choice.

- Programming environments for Python, Java, Scratch, Sonic Pi, Mathematica\*, Node-RED, and the Sense HAT emulator
- The LibreOffice office suite
- Chromium (including Flash) and Epiphany web browsers
- Minecraft: Pi edition (including a Python API)\*
- Various tools and utilities

**Figure 52: Raspbian Specification list**

## 3.16 Programming Languages

### 3.16.1 Python

Depending on what OS will be selected, certain languages will be available. The Raspberry Pi comes with Python installed. C++, PERL and Java can be used. Python is the main language for the Raspberry Pi and was Created by Guido van Rossum and first introduced in 1991. Python is a extremely powerful language and has a concise syntax than can express concepts in fewer lines of code than Java or C++ can. It has the IDLE environment which is a Python development environment and makes it an easy introduction to the language if the user is new and the language is a very readable language [52].

### 3.16.2 C++ and Java

According to Professor Paul Zoski and Professor Jeff Salvage at Drexel University, object oriented programming is “[...] based upon theories from the field of cognitive science about how information is represented in the human mind.”( Zoski), and while one does not need an academic degree in psychology to understand the fundamental aspects of object oriented programming, it is worth to note that a keen understanding of how humans interpret nouns and verbs is helpful in understanding how object oriented programming languages work. As the Automated Pet Feeder has several parts, an object-oriented programming language is essential to model all of these real-world objects in the devices that will act as the brain of the system. Several object-oriented programming languages exist, though a thorough understanding of two of the most prominent ones, C++ and Java,

is crucial in understanding which one is best suited for the software purposes of the Automated Pet Feeder.

The first notion that will be expounded on is the description and background of the object-oriented programming language C++, which is one of the most widely used object oriented programming languages today. Though not an entirely new programming language at its birth, Professor David Bernstein at James Madison University in his article explains that C++ was initially a derivative of C that included object oriented programming capabilities. Professor David Bernstein continues to say, "The language [now C++] was re-designed and re-named C++. Originally, C++ source code had to be "pre-compiled" (the pre-compiler converted C++ constructs to plain C)" (Bernstein). In this quote, Professor David Bernstein explains that that C++ originally had to be converted back to C before it could be implemented, however, overtime it attained the general attributes of any other object-oriented programming language. While one could sum up C++ by stating that it extends the abilities of C by including object oriented capabilities, there are other object-oriented programming languages also used extensively in recent years.

The second notion that will be expounded on is the description and background of the object-oriented programming language Java, which, like C++, is one of the most prominent object-oriented programming languages. The history of Java is unique in various aspects, even down to the nomenclature that occurred, and extensive research has gone into educating future computer scientist concerning this language. One such prominent educator is Dr. Hamid Nemati, who has conducted extensive research in the area of information security and several other areas of computer science prior to holding his current position at the University of North Catalina. In his lecture entitled "Introduction to Java", Dr. Nemati says that Java was intended to be "A general-purpose programming language for developing software that can run on different platforms." (Nemat"). In the same lecture, Dr. Nemati continues to explain that Java was intended to be a futuristic language that would work with "smart" devices in the future, particularly devices that have the ability to communicate with each other. Dr. Nemati concludes the brief history of Java by explaining that the Java programming language was not created arbitrarily, but was as a result of extensively implementing and modifying concepts and ideas from the already created C++ object oriented programming language for a specific project. This all concluded in the Java programming language being born, and while it shares the similar object-oriented characteristic with C++, there are still numerous differences and similarities between these two object oriented programming languages.

The third notion that will be expounded on pertains to the similarities and differences of the two object oriented programming languages C++ and Java. While these two programming languages are inherently similar in the fact that they incorporate object oriented capabilities, there are still many other prominent similarities and differences that have caused both languages to be implemented for different purposes over the years. One such individual who has documented the change in usage, similarities, and differences of many programming languages, including Java and C++ is Don MacVittie, and in his article published by *United Business Media LLC* that is titled "Contender or Champ? Judging Java", he explains that if one is looking for simply performance, C++ is

better suited for such usage rather than Java. Mr. MacVittie notes that this is primarily due to the fact that C++ is more efficient than Java, which has caused C++ to be implemented heavily in environments where low time latencies are imperative, such as data networks and command-line applications. Mr. MacVittie continues to note that while C++ has the upper hand in efficiency, it lacks portability when compared with Java. He notes that a Java application, unlike C++, can be implemented on any operating system that supports the Java programming language, and that “[...] Java is an interpreted language, meaning that routines can be written to handle a vast array of possibilities based on the state of the system. Developers can create user-defined data types on the fly, whereas C++ is limited to the complex data types designed prior to the system's compilation.” (MacVittie, 1999). In the previous quote, Mr. MacVittie explains that when compared with C++, Java enables the programmer with greater flexibility concerning variable usage and data types prior to the programmer compiling his or her code. From personal experience, this enables one to be more confident in the code that he or she is writing, as one can detect errors as they appear prior to compilation. While the differences between these two object oriented programming languages are seemingly endless, there are several similar fundamental characteristics that have allowed programmers to transition back and forth between these two languages.

The prominent similarities between the two object oriented programming languages Java and C++ are miniscule with respect to their prominent differences, and one could easily validate this notion considering that this is the reason Java was created. One such individual who has conducted extensive research concerning the similarities of these two programming languages is Ahmed Khan, and in his published article from *Iqra University* titled “Comparative Analysis of Java & C++”, Mr. Khan explains that while Java and C++ are both object oriented programming languages, Java was initially designed to be implemented on embedded systems, and although it has evolved significantly since then, Java still shares that attribute with C++; the ability to be implemented on embedded systems. Mr. Khan continues to explain that while Java and C++ have gained their strong points over the years, both languages have complemented each other through the creators implementing ideas from the other programming language to create more useful revisions of both languages (Khan). Finally, considering that Java was created to fulfill C++'s shortcomings, and that C++ was created to implement object oriented capabilities in C, it is not wonder why the prominent similarity of Java and C++ are their syntaxes. From using semicolons to terminate statements, to the implementing nearly the same arithmetic operators, the syntaxes of Java and C++ has enabled programmers to take advantage of this similarity to easily transition between languages.

For the purposes of the Automated Pet Feeder, a programming language that has a well-established set of libraries suited for embedded applications is crucial. This is one of the significant reasons why C++ was chosen to be the programming language of choice for implementation in the Automated Pet Feeder. C++ also has direct access to the memory of the system it is implemented on, therefore giving the user total control as to when space is used, how much space is used, and when each process is executed.

## 3.17 Databases

The Automated Pet Feeder's hardware produces important data that needs to be stored and needs to have the ability to go back a reference data from different time and days. This is where a database comes into play because it is able to hold a collection of data in an organized fashion. There are many free open source databases available and by utilizing open source database software, it will not add an additional cost to the Automated Pet consumer. An example of how a database will be used is that it will have the capability of storing how much food has been dispensed over time, which can translate a history chart for the user and that same information can let the user know when it would be time to order more food before it runs out. PostgreSQL, MySQL, Firebird, and MariaDB will be the options discussed in this section.

### 3.17.1 PostgreSQL

This PostgreSQL has a proven track record for reliability, data integrity and correctness and has been around for almost 15 years. It is available for mostly all operating systems such as Linux, UNIX, Solaris, Mac OS and Windows. It has the capability to handle different types of data such as video, sound, images and data types. It is very well documented and can be programmed in multiple languages including C/C++, Java, .Net, Perl, Python, Ruby, Tcl and ODBC and it has a large library interface in those languages as well. It uses a generalized search tree which uses different sorting and searching algorithms such as B-tree, B+-tree, R-tree and partial sum trees and queries methods and data types can be custom made providing user versatility [48].

### 3.17.2 MySQL

MySQL is owned by Oracle and has been around since 1995 and is used by large companies such as Facebook, Adobe and Zappos. It is compatible with all major operating systems and is written in C and C++. There is plenty of documentation on how to set up a database design and gears the user into the right direction for their specific project. They promote themselves on high availability data so if the network cannot be accessed the database still can be used offline. The only downside to this database is that, since Oracle owns MySQL it is no longer community driven, so it is not updated as often, or members cannot crowdsource patches or fix bugs [49].

### 3.17.3 Firebird

Firebird has been around since 1981 and can run on Linux, UNIX and Windows. It is a relational database system that performs scales to the size of the application seamlessly. Firebird is capable of serving as an analytical and operational database. It can support a database of up to 20 Terabytes data can be backed up using two methods: Online backup and Incremental backup. There is free online support in the Firebird community with extensive documentation how to install and setup the data using different operating systems [50]



### 3.17.4 [MariaDB](#)

MariaDB is a MySQL free open source alternative and companies like Wikipedia, WordPress and Google use this database. It is scalable and has plenty of storage engines which makes it a very versatile tool. Use MySQL interfaces and since security is a top priority for them, when MySQL patches are released those are the same patches applied to MariaDB. MariaDB can be used on most operating systems like Linux and Windows.

## 4 Design Constraints and Standards

### 4.1 Senior Design Constraints

#### 4.1.1 [Parts List Budget](#)

In the beginning of Senior Design 1, our team created an excel with proposed parts and how much they were going to cost the overall project. It would have been excellent to have an unlimited budget, but unfortunately the cost of supplies and parts can limit a project quickly. When cost is a limited factor, quality of the product can possibly decline. Our team did not want to sacrifice a safe and working design due to the just cost itself. The team proposed a budget of 154 dollars with the confidence that a safe, functional, aesthetic and timely product will come about in the end. The project requires components that need to be custom-made and with the help of a 3-D printer, it can be possible. Even though 3-D printing can be quite expensive, either buying one or paying for a third-party company that provide the team with the parts, it would definitely go over the intended budget. Fortunately, one of the team members already owns a 3-D printer and the only cost that we would have to worry about it purchasing the filament and time. 3-D printing definitely takes up multiple hours especially if the pieces are at a large scale. It is necessary for the team to plan accordingly and print the pieces ahead of time to not be rushed or risk running out of time designing the rest of the project.

By setting weekly deadlines, our team was able to research their assigned parts their parts in a timely fashion. The parts list was broken up into three sections and each member did product comparisons. When each part was researched. In order to make sure component quality, three or more of the same type of device was compared to ensure obtaining the best cost for the best specifications for what is needed for the project. Decisions needed to be made whether buying brand name components offset the cost or can the same task be accomplished by purchasing brands that are from third party companies and rollover the money saved into components that are essential and worth the extra premium. Research was done if our team was able to salvage components from old devices, but unfortunately either the parts were damaged to there was no brand associated with the part and because of that, a datasheet was not obtainable. Using unknown components is quite risky, since the operational voltage is unknown and can either burn out if too much voltage is applied or can burn out other components unintentionally. By patiently doing parts comparisons and In Section 3 of the report, he team was able to obtain the components but slightly went over budget. The total cost all

the parts purchased was \$159.11. Even the budget went over, our team is confident that the parts chosen for the project would be ideal for the production of a machine that would put out excellent performance but also be aesthetically pleasing to the consumer, functional and safe for the pet.

#### 4.1.2 Time Constraint

Time is the most unforgiving constraint for any project but, it is a serious and most important factor to consider. The project must be completed within two semesters. Senior Design 1 is the research and design/ prototype stage. This stage is a total of about 16 weeks and fortunately it gives our team ample time to research and brainstorm how the PCB design will be laid out and ideas for how all the separate components will interact with each other for the Automated Pet Feeder. Stage two is Senior Design 2 and in this stage, our team will have to take those ideas and test and build the overall design. 3-D printing consumes a lot of time and sufficient time is needed to accommodate any errors that may arise due to a faulty enclosure print. The key is to start early and take advantage of the winter break. The goal is to have all the separate components tested and working with each other before the start of Senior Design 2, that way our team can use that remaining time to make the current circuitry efficient and aesthetics can be a focal point as well. Not only we want the Automated Pet Feeder to be working at 100 percent, but aesthetics is a key point if the product is going to attract consumers. Also, by starting early, the PCB design would be complete, and our team would just have to worry about sending it out. During this phase it will be critical for the software and application development to be complete as well. Senior Design 2 will have a tighter time constraint of about 12 or 13 weeks and that is why time management and keeping track of the project's milestones will be a key factor into having a successful project. By keeping track of our milestones, our team can visualize week by week on the next task at hand.

#### 4.1.3 Final Product Price Constraint

As the design process unrolls, our team has to make sure that we consider the components we use, and the time involved is reflected in the final price of the product. The Automated Pet Feeder cannot be an absorbent price which will be unattractive to consumers and prevent them from purchasing this product. Our team advertised the product to be beneficial for different pets who require scheduled feeding. At first, the product was only targeting dogs but, there is another market for cats that can expand possibilities for more profit. So, catering to a broader audience attracts consumers to be curious about what the product does and how it can benefit them. If our team is able to bring down the cost of production that can be reflected in the final price all profits can go into researching better circuitry and present, the opportunity to enhance the design.

Another factor to consider is the consumption of energy it requires for The Automated pet feeder to run. This factor will be important when designing the power supply and the PCB circuit board. If we are able to use components that do not need high operational voltage to work and they have a low current draw this can benefit the consumer immensely and they would not have to worry about leaving the device connected because it requires too much power to run. Since the product will have a water filtration system to have a constant flow of fresh water, that can raise the price. By our team researching which water pump is the most economical and energy friendly pump, the consumer can benefit

from the energy savings make them more likely to purchase the system. Another way to make energy savings for the consumer is to create code that will run the filtration system at time intervals. By doing this, the pump doesn't not have to run constantly 24 hours and seven days a week. Also, over working a component without letting it rest can drive up maintenance cost and burn out the pump from over use. Not only it is crucial for the water pump to be easily accessible for any type of maintenance, it also has to be accessible to cleaning as well. The 3-D printed enclosure has to incorporate a lid that be easily opened or easily taken off for any type of routine cleaning. Keeping the system clean ensure that the pet will not get sick from bacteria or mold growing just because the owner is not able to access certain spots to clean. This also includes having the food bowls accessible at all times. The owners need to sanitize where the pet is eating daily to make sure that they will remain healthy. Our team also wants to make sure that the product requires minimal maintenance. Since the enclosure of the Automated Pet Feeder will be 3-D printed, making sure our team selects the correct type of filament is critical. The final design and production of the enclosure has to ensure that there are no cracks for the water reservoir where water can seep through. If there is any chance of a water leak, this can cause the whole system to damage, and destroying valuable electrical components rendering the pet feeder useless. Another maintenance issue our team has looked into is the food dispensing system. Determining whether the final product will use either a rubber paddle or a 3-D printed flexible paddle. Research has to be put in which material is less likely to deteriorate over time. If the material starts degrading, there can be the possibly that some of material falls into the food and the pet can accidentally ingest it which can be a huge liability. This is why researching the best filament that is engineering grade and FDA compliant for food contact is critical. Once all this these requirements have been met, the pet owner can safely operate and sanitize their pet's feeding station and just have to worry about if their pet is comfortable.

## 4.2 Standards

### 4.2.1 IEC Power Standards

While the discovery of electricity was several centuries ago, the full benefits and impact of it were not seen until less than a hundred years ago. This rapid development and utilization of power throughout the commercial sector, private sector, and residential industry prompted several countries to develop standardized power distribution centers to fulfil the rapid growth. However, this was far before the International Organization for Standardization was founded, thus different countries developed their own individual standards for use in various ways. As the Automated Pet Feeder is designed to be used in the United States, the electricity standards for the United States are of importance. However, expansion to other markets, most notably European countries, would require knowledge of the several standards for electricity in the European countries of interest.

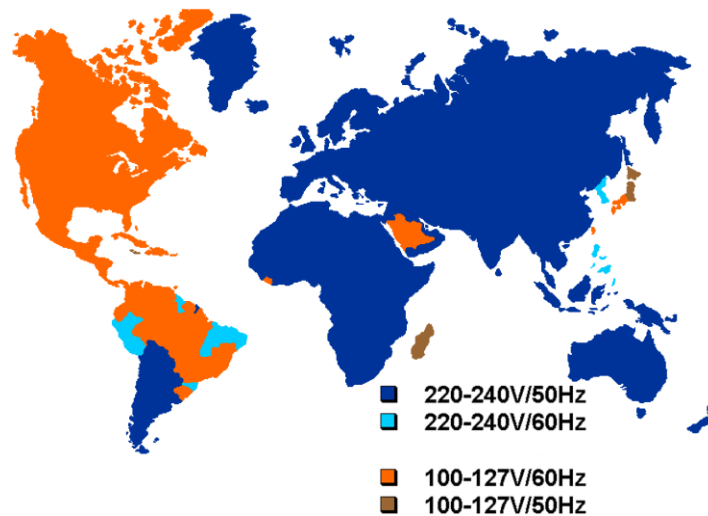

**Figure 53: World Wide Power Standards**

While the majority of European countries and the majority of the remaining portion of the world utilize power with an electric potential between 220 volts and 240 volts, the United States and Japan are one of the few countries to utilize power between electric potential magnitudes of 100 volts and 127 volts [79]. The frequency at which the current is supplied through this power is at 50 hertz, and while Nicola Tesla had originally concluded that 60 hertz provided the most efficiency, the 50-hertz standard came from the monopoly of the German company AEG that constructing the first electricity production facility in Europe. As the metric system was being pushed forward extensively at the time, this blinded the standard creators to opt for the 50 hertz over 60 hertz as the creators wanted to keep in uniformity with the metric system's order. This misguided decision has culminated in merely six countries utilizing Tesla's efficient design, while the remaining countries in the world use the inefficient design developed by AEG. This has caused the energy generation to be less effective by 20%, and the transmission of energy through conductive mediums to be 10-15% less efficient as well.

While Europe and the majority of the world operates at above the 200 volts electric potential region, it was not too long ago that Europe too, operated at 110 volts as well. Nearing the beginning of the Wald War, it was universally decided that 220-240 volts provided an advantage over 110 volts. As power is equal to the product of the square of current and resistance, it is imperative that the current be kept to a minimum so as to let the smallest amount of power be lost through transmission. While the current may be relatively low, the energy transferred can be greater than that of 110 volts systems as 230 volts systems have a higher voltage, thus greater energy transmission is possible without increasing losses. The primary reason Europe and the majority of the rest of the world were able to make the transition to a grid with higher electric potential was that these countries' electrical infrastructure was not as developed as the United States'. At the time of the transition in Europe and other countries, the average United States household already had a refrigerator, therefore changing all household appliances that were already dependent on existing power infrastructure proved to be too expensive.

### 4.2.2 Filament Standards

The consumers pet’s health will always remain the upmost important requirement when designing the automated pet feeder. It is for that reason that the material being used to design and construct the automated pet feeder is non-toxic and FDA approved to ensure no pet is at any health risk. Since the pet will could possibly have physical contact will all sides of the pet feeder, we decided as a team that the pet feeder be only constructed with 3D printing filament that is approved by the FDA and deemed safe for contact with dry and wet consumables. As described in the 3D printer materials section of this paper, there are many different characteristics and benefits of using a particular filament versus others such as ABS, PLA and Nylon. Since filaments like ABS and nylon have toxic properties to them, they cannot and will not be used in the making of the automated pet feeder. Many different companies such as T-Glase, Maker Geeks, Tech G and many others offer many options of FDA approved filaments. When comparing between different makes and models of FDA approved 3D printing filament, most come in similar diameters such a 1.75-millimeter and many different colors. When coming to a decision which would be best for the automated pet feeder, we will need to test a minimum of three of the top-rated FDA approved 3D printing filament to make a more educated and precise decision on the one filament would be more beneficial to use versus another filament. We will also need to check on the maximum and minimum requirement when pairing the filament with the Creality CR10 3D printer that we will be utilizing to ensure that it will properly print.

Data sheet only for reference, final data sheet please do not hesitate to send us a enquiry to ask from us

Item	ABS	PLA	HIPS	Nylon/PA	PC
Printing temperature	230~240°C(NC) 240°C(SC)	220~230°C (NC) 230°C(SC)	220-240°C	230~270°C	230~250°C
Diameter	1.75mm 3.0mm 2.85mm	1.75mm 3.0mm 2.85mm	1.75mm 3.0mm 2.85mm	1.75mm 3.0mm 2.85mm	1.75mm 3.0mm 2.85mm
Diameter tolerance	±0.05	±0.05	±0.05	±0.05	±0.05
Color	16 color Custom	20 color Custom	2 color Custom	3 color Custom	3 color Custom
Net weight	1kg	1kg	1kg	1kg	1kg
Package	Vacuum	Vacuum	Vacuum	Vacuum	Vacuum
Suitable 3D Printer	Makerbot,UP,Solidoodle,NesStarWay,Leapfrog,Afinia,Ultimeker,Mendel,Prusa I3...				

  

Item	POM	TPE/TPU/Flex	PET/PETG	Wood	PVA
Printing temperature	230~270°C	220~240°C	240~260°C	220~260°C	160~180°C
Diameter	1.75mm 3.0mm 2.85mm	1.75mm 3.0mm 2.85mm	1.75mm 3.0mm 2.85mm	1.75mm 3.0mm 2.85mm	1.75mm 3.0mm 2.85mm
Diameter tolerance	±0.05	±0.05	±0.05	±0.05	±0.05
Color	1 color Custom	3 color Custom	3 Custom color	1	1
Net weight	1kg	0.5kg	1kg	1kg	0.5KG
Package	Vacuum	Vacuum	Vacuum	Vacuum	Vacuum
Suitable 3D Printer	Makerbot,UP,Solidoodle,NesStarWay,Leapfrog,Afinia,Ultimeker,Mendel,Prusa I3...				

**Figure 54: Typical datasheet for 3D printing filament**

Once again, when designing the automated pet feeder, the consumer’s pet’s health needs to be the number one factor. Every component used to construct the automated pet feeder will be verified for food grade standards if that component will be coming in direct contact with both the dry food and the water supply of the feeding system. The automated pet feeder will be fabricated using our very own Creality CR10 3D printer. The reason we decided to use a 3D printer is because it allows for an ease of design and cost reduction. Although cost and design benefits are great, we need to ensure the material used in the 3D printing process is food grade safe material. With 3D printing becoming more and more popular, there are numerous filaments that come in all different material and a variety of colors. Some of the most popular filaments for 3D printing purposes are PLA,

ABS, FLX PLA, Nylon, PETT and plenty more. Each comes with certain benefits versus other filaments.

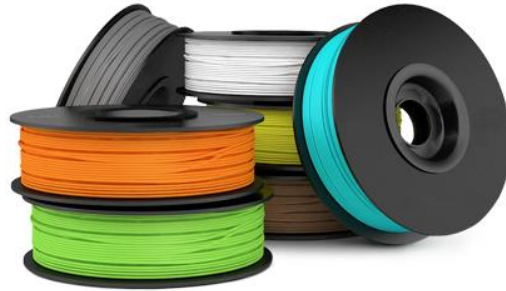

**Figure 55: Example of roles of different 3D printing filament**

Acrylonitrile Butadiene Styrene or ABS for short, is very a very popular material/filament used in the 3D printing industry. Some notable features being that ABS has a very high melting point compared to other filaments. For this reason, ABS can be used in applications that may be susceptible to higher heat conditions. With ABS having a higher melting point, the printed objects tend to hold their shapes longer than other material would. Another feature is that ABS printed pieces are considered to be a more sturdy and solid articles. With that being said ABS does have its downfalls. ABS is oil based and can be harsh on the environment and not suitable for food handling purposes. With ABS being an oil-based material, when printing, ABS tends to release fumes that may have negative effects on to the consumer's health if in constant contact with these fumes. With as high as a melting point that ABS have, the printing speed is much slower thus causing longer printing times. Another flaw due to its high melting range is that it may require a heated printing bed or possibly a printer enclosure to ensure for proper printing without warping or other heat and cooling inflicted flaws.

PLA, also known as polylactic acid, is another popular filament in the 3D printing realm. PLA is known for its biodegradable thermoplastic properties. PLA is formed from a base of cornstarch and sugar cane. With a significantly lower melting point than ABS, 3D printing with PLA is much faster and does not have the requirement of extra components for printing such as a heated printing base or a printing enclosure as does ABS. Since PLA is made of natural materials, when printing, the fumes are considered safe for consumers and free of any harm. Another benefit of its biodegradable plastic is that it is safe to use for container or utensils that may come in contact with food. Like ABS, PLA has its shortcomings as well. With such a low melting point, PLA can lose its shape or design from high temperature applications, which can limit its application possibilities. Not only can PLA lose it shape from high temperatures, but also PLA is seen as a filament that is not as strong as ABS unless printed in thicker forms or shapes.

Nylon is also known as polyamide. This is seen as a "high-end engineering thermoplastic" [86]. It is known to be extremely tough and durable. Its strong and flexible properties make it ideal for a magnitude of applications that require a little more ruggedness. With its strong properties, nylon can be great for parts that can be drilled, tapped or even screwed [87]. Nylon is flexible when thin, but it has a very high inter-layer adhesion reduces the chances of breaking or shattering. Although this filament may sound great due to its great strength and elasticity, there are some drawbacks when using nylon. The

biggest issue when using nylon when 3D printing is its extremely high melting point of over 240 degrees Celsius. With such a high melting point, special printing hot ends must be utilized in the printing process since most 3D printer hot ends are not rated for that high of a melting point. Another drawback would be that nylon could easily be warped in the printing process if the filament is not properly prepped before starting the printing procedure. Nylon plastic is very hygroscopic. That means it readily absorbs water from the air. Nylon can absorb more than 10% of its weight in water in less than 24 hours [YYY]. Like seen in ABS, nylon is also a filament that must be used in a well-ventilated area and the consumer must minimize all contact with its hazardous fumes.

When printing parts for the automated pet feeder, the deciding factor of which filament to use was determined on whether or not the material being printed will be coming in direct contact with the pet or the pet's food. We decided that although the pet may not come in direct contact with all the material that will be printed for constructing the automated pet feeder, that all the filament that will be used will be FDA approved to ensure the consumer's pet will be safe from any possible toxins that can be released from other non-FDA approved filaments.

#### 4.2.3 Water Quality Standards

All pets need fresh and an adequate amount of water based on your animal's needs. Water that is stagnant and exposed to the open air can become easily contaminated over long periods of time. The longer water sits out the more oxygen it loses and the more susceptible it becomes to bacteria and other possible health concerns for the consumer's pet. It is for these reasons that the automated pet feeder will need to uphold to a few requirements that pertain to managing how the water will be handled. The water that will be stored in the water reservoir must not remain in contact with the dispensed water that has been sitting out. By not allowing the reservoir to come in contact with previously dispensed water will ensure that the water that is being stored is as fresh as could be and free from possible contaminants. The water reservoir of the automated pet feeder needs to have a lid that provides an airtight seal. The seal that will be used to close the water reservoir will ensure that the water will not be getting contaminated and allow for the cleanest and freshest possible water to be dispensed for the consumer's pet. As discussed in the materials requirements for the automated pet feeder, the water reservoir needs to be constructed of FDA approved 3D printing filament. Using FDA approved filament will ensure once again that the safety of the pet is not in jeopardy with possible toxins that can be found in other filaments that are not FDA approved. By ensuring that the material is FDA approved when 3D printing, the water reservoir has an airtight seal, and the reservoir is never in direct contact with previously dispensed water, allows for the automated pet feeder to be a safe device that the consumer can rest assured that it will not jeopardize the health of his or her pet.

#### 4.2.4 Rain RFID Standards

RFID standards are beneficial for companies because it gives the company information such as how the systems work, how the data transfer is interpreted, what frequencies the RFID system must operate at and most importantly how the communication between the RFID reader and tag work. There is a single global standard as an example called EPC

UHF Gen2v2 or ISO/IEC 18000-63 and it regulates RAIN RFID approving protocols or instructions that can be used anywhere and in any industry for the RFID equipment. Rain RFID can store RFID data and can be modified, stored and shared via the internet. For example, the Federal Communication Commission regulates the use of RAIN RFID frequency band within the United States [71].

ISO/IEC 18000-63 determines RFID frequency air interference between 860MHz to 960 MHz in the Scientific, Industrial and Medical bands applications. Those devices are given universal specifications for selected RFID devices that are used by the ISO committees. The specifications that are usually regulated are “operating frequency, operating channel accuracy, occupied channel bandwidth, modulation, duty cycle, bit coding, bit rate, bit rate accuracy, bit transmission order, and further defines the communication protocol used in the air interference” [80].



# 5 Design

## 5.1 Schematics

### 5.1.1 Schematic Design – Power Supply

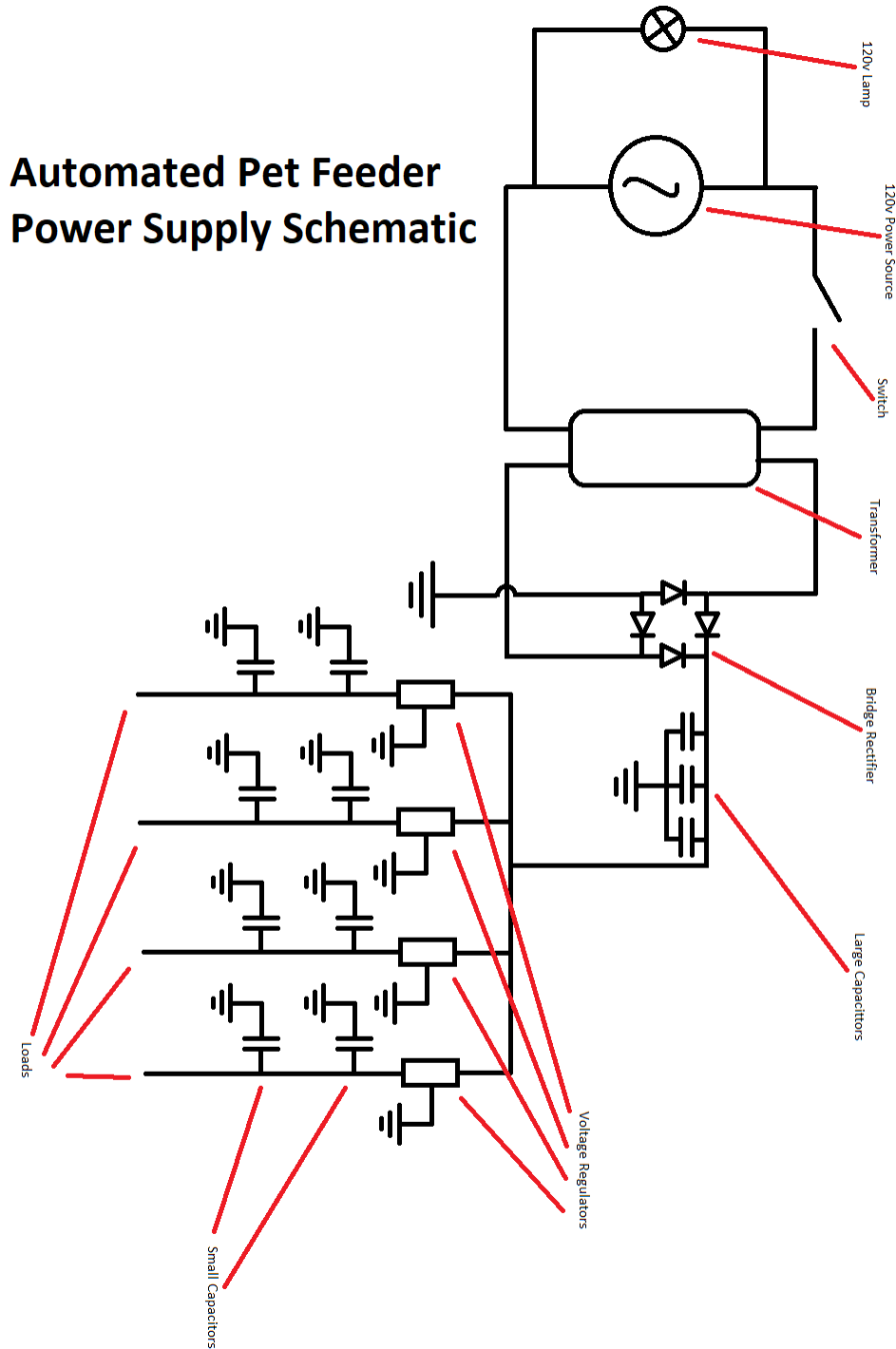

**Figure 56: Automated Pet Feeder Power Supply Schematic - Design & Created by Malcolm Morgan**

## 5.2 Interface

### 5.2.1 Hardware User interface

The Automated Pet Feeder needs to be controlled by both the application and by manual operations. If for some instance the application fails, the consumer needs to be able to dispense food to his or her pet. Other features such as buttons used to program data to be stored in the automated pet feeder. Most of the hardware side of the user interface will consist of simple push buttons that the user will push in a given manner to achieve a desired output.

It is extremely important that the Automated Pet Feeder be equipped with a manual override button. This button will be accessible to the user but accessible to the pet. Whether the app is failing or if the user wants to feed his or her pet at any given moment, the user will be able to push the manual dispensing button and food will begin to dispense into the feeder's bowl. The food that will be dispensed in the bowl will be taken in account for and will calculate nutritional data just as it would if it were a preprogrammed feeding. This feature gives the user complete feeding control both through the app and manually. Another button that the feeder will be outfitted with will be a button that will be utilized in programming how much food will be dispensed for each feeding. The user will have the option of using the manual feed button to fill the automated pet feeder's bowl to his or hers pets desired amount of food. Once the user has the desired amount of food in the bowl, the user will then hold the set button for about three to five seconds until the scale calculates the current weight and stores it in the memory of the automated pet feeder's system. Once again this give the consumer not only control via the application but also by a fairly simple manual procedure.



**Figure 57: Examples of Different Style Momentary Switches**

The buttons that will be applied in the design of the automated pet feeder will be momentary style buttons. Momentary buttons are only active during the duration that they are being pressed. This style button could be used to change between options or

programed to check how long it is being pressed and depending how long or short the button is pressed could perform different functions. The costs of such buttons are minimal which help in keeping the cost down for the consumer. These buttons are also great because they tend to be fairly shallow buttons, which tend not to break as frequently as standard toggle switches.

## 5.2.2 Software User Interface

According to Statista, over 3 billion applications have been developed for the Google Play store, and while this number continues to grow each day, there are several common correlations between all the apps that are developed [72]. One of these correlations is none other than User Interface, as each app is designed to have a user interact with the app. More light is shed on the terminology, User Interface, through the following excerpt from *usability.gov*, which says “User Interface (UI) Design focuses on anticipating what users might need to do and ensuring that the interface has elements that are easy to access, understand, and use to facilitate those actions. UI brings together concepts from interaction design, visual design, and information architecture.” Essentially, User Interfaces combine the ability to interact with, visuals, and details to allow the user to perform the desired function more effectively [81].

Several types of User Interface exist, though one of the most prominent types that has risen in popularity throughout the past few decades is the Graphical User Interface. The Graphical User Interface is a collection of tools and objects that a user utilizes to navigate throughout a graphical environment. Several tools that the Graphical User Interface employs to perform its designated function include the Pointer, Pointing Device, Icons, Desktop, Windows, and Menus.



**Figure 58: Pointer**

The first portion of the Graphical User Interface that will be elaborated on pertains to the pointer. The pointer is a dynamic symbol displayed onto screen that conveys the location of a possible action the user might perform [76]. This pointer can be used to cycle through menus, select menus, navigate through extended pages, and shorten the time required for navigating documents when word processing. The specific shape and location of the pointer may not always be determined by the user, as the pointer can be limited to a specified dimensional boundary by the system, or applications running on the system. Applications are also permitted to alter the shape and orientation of the pointer. This is

especially seen in word processing, wherein the pointer may transform into a I-beam pointer, an italicized I-beam pointer, or disappear completely in some instances.



**Figure 59: Computer Mouse**

The second portion of the Graphical User Interface that will be elaborated on pertains to the device utilized to control the pointer, which was previously discussed [75]. Throughout computing history, several different devices have been invented, patented, and moved forward into mass production to fulfil this purpose. One of the most prominent devices invented to perform this function is the computer mouse [74]. Invented by Douglas Engelbart in the year 1964, the original computer mouse was constructed out of wood, and contained an integrated circuit that featured two wheels made of metal that came in contact with the surface whereon the computer mouse was operated. This design, however, was limited, as having fixed wheels limited the two-dimensional movement of the computer mouse. This limitation prompted the development of the computer mouse that was most common in the past several decades, which is the ball mouse. Developed in 1972 by the inventor named Bill English, the ball mouse incorporated several functionalities of its predecessor, however, the ball mouse utilized a ball to make contact with the surface that it rolled over, and transferred readings of position change in position with respect to time to the system that the ball mouse is connected to. This allowed the ball mouse to be used in any direction on a two-dimensional plane, thus generating electrical pulses whenever motion occur, which was then sent back to the device and decoded into information such as position, and change in position with respect to change in time. The final revision of the computer mouse became a reality eight years later, when in 1980 the optical mouse was invented. This combined the performance of the ball mouse into a package roughly the same size, but with greater reliability and usability, as the ball mouse was prone to performance issues over time when its ball would become dirty. The optical mouse utilized optics and a laser to perform the same functions as the ball mouse, such as tracking position and change in position with respect to change in time. While initially expensive to produce, mass production eventually swung in the favor of the optical mouse thus reducing cost from originally \$35 in 1988 to just a few dollars in recent years. This allowed the optical mouse to be utilized in inexpensive computers, and the increase in processing power of microprocessors and microcontrollers allowed for the optical mouse to be a viable option for just about any application.



**Figure 60: Popular Social Media Icons**

The third portion of the Graphical User Interface that will be elaborated on pertains to a generic item utilized extensively in the Graphical User Interface [82]. This item is none other than the icon, which is a small collection of pixels used to display a picture that represents windows or files. These icons must be used in conjunction with the previously mentioned pointer, as the execution of the functionality of the icons must be performed with a pointer. When the pointer is employed to execute the function on an icon, the icon may perform several functions, such as expansion, minimalization, size reconfiguration, termination, and many other functions. While many forms of icons exist, all can be placed into two primitive categories; dynamic icons and static icons. Dynamically sized icons allow the user to interact with the dimensions of the icons, whether through manually resizing the icon, or through selecting a predetermined function that alters the icons dimensions. In contrast, statically sized icons do not allow the user to alter their dimensions in any way, shape, nor form. Thus, the only function of a statically sized icon is to perform another designated function, which is more than often to launch an application or yet another icon.



**Figure 61: Computer Desktop**

The third portion of the Graphical User Interface that will be elaborated on pertains to the desktop, which may be referred to using different terminologies depending on the platform wherein they are employed. The desktop serves as the main area that the screen displays content, which also serves as a housing medium for the menus previously mentioned.

The terminology stems from the real-world object, which is a desk [77]. As a real desk serves as a place where one stores objects and supplies to perform particular functions, especially computing functions, it is no wonder why the term desktop was used to designate this environment.

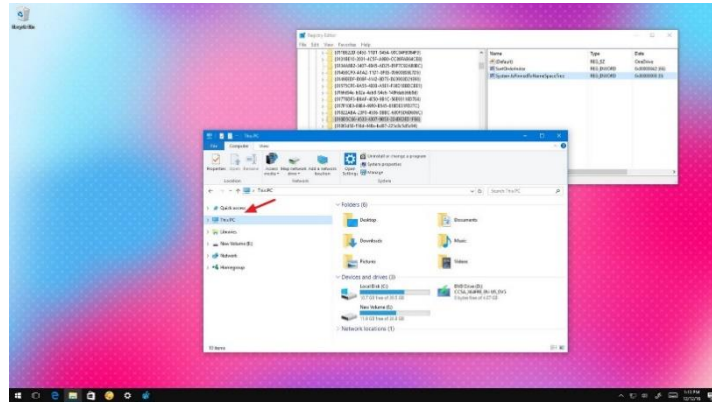

**Figure 62: Several Windows**

The fourth portion of the Graphical User Interface that will be elaborated on pertains to the several collections of boxes used to perform task, which is referred to as windows [83]. While the term was coined by Microsoft, this terminology has been employed on various operating systems, and not just on the Windows operating system produced by Microsoft. The windows in the Graphical User Interface allows the user to run multiple programs at once, thus increasing productivity and ultimately allowing the user to multitask.

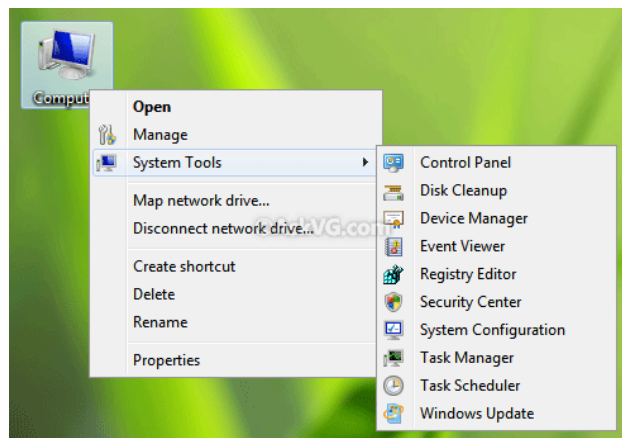

**Figure 63: Nested Menus**

The fifth and final portion of the Graphical User Interface that will be elaborated on pertains to menus. The majority of Graphical User Interfaces allow a user to execute functions through choosing a particular option in the menu [78]. This allows a user to be able to transfer data between several applications, allowing the user to multitask to a greater extent. Most menus are bound by dimensional and visual constraints by the operating system, therefore while a menu may perform the same function on different platforms, the visual and dimensional characteristics of the menu might be different, as

the operating systems ultimately determines a great deal of the menu's design, but not the menu's functionality.

## 5.3 Dispensing Method

The method in which the Automated Pet Feed would dispense the dry food into the bowl was discussed and observed in great lengths. This is a crucial design requirement for the Automated Pet Feeder. Whichever method is chosen for the feeder needs to work flawlessly to ensure the nutrition of the pet is never in jeopardy. Many different styles are many different methods that could be used for dispensing dry food. We could possible design and print a dispensing mechanism with the 3-D printer that is available to the design team. Another option would be to use a sliding door that opens and closes when dispensing the dry food. Lastly the automated pet feeder could use a dispensing mechanism that is already in use in the dry food dispensing industry.



**Figure 64: Example of Wheel Design for Possible 3-D Printing**

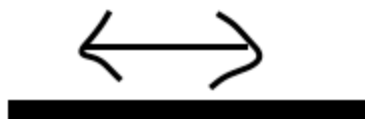

**Figure 65: Example of 3-D Printed Plastic Sliding Door**

The possibility of 3-D printing a dispensing mechanism would be a great option for its cost reducing ability. The issue with 3-D printing our own dispensing contraption is that our 3-D printer only prints material out of plastic. If it were decided to use some sort of rotating mechanism this would be an issue because an arm to the rotating mechanism could get stuck with a pebble and the reservoir wall. If this were to happen, this could lead to one of the arm breaking and ending up in the pet feeder bowl. This would be an example of a failure that could lead to a pet getting severely injured if this piece of plastic becomes ingested.

Another viable option is to utilize a horizontal door at the bottom opening of the reservoir. This could be implemented easily and cost effectively by 3-D printing a simple door that covers the shape of the opening. When the dispenser needs to dispense food, the door will slide to the open position. When the feeder indicates it needs to stop dispensing food,

the door will slide back to the closed position. The issue with this idea is gravity. The pebbles will continue to fall even while the door is closing. With the dry food still falling while the door is closing, this allows for the system to easily become jammed and not ensure that food will not continue to dispense.

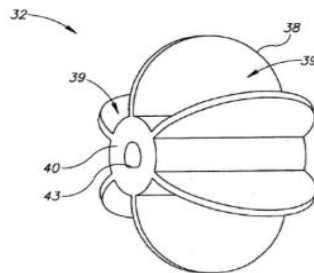

FIG. 3A

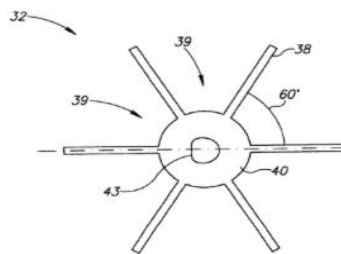

FIG. 3B

**Figure 66: Patented Rubber Paddle Wheel**

Lastly, the option of purchasing a fairly cheap dispensing wheel could possibly be the best solution. While researching dry food dispensers, it was noticed that many similar applications utilize a rubber paddle wheel. The design of the rubber paddle wheel allows for bending in each arm to ensure for proper dispensing even if pebbles become jammed between the opening and the paddle arm. As the wheel rotates when dispensing the dry food, there will consistently be food in each opening that will eventually be dropped into the pet feeder's bowl when it reaches the bottom of the rotation. This design allows for the paddle to be position closely to the lining of the reservoir opening the make sure there are no gaps that pebble could possibly slip by into the bowl accidently.



**Figure 67: Example Use of Rubber Paddle Wheel in a Cereal Dispenser**



After examining the options for what mechanism would be used for dispensing the dry food, it was determined that it would be best to use the rubber paddle wheel that is used in the industry already. When designing the automated Pet Feeder, the pet's safety is the number one concern and we could not take the risk of plastic possibly making it way into the pet feeder's bowl. We also could not utilize a slide door option because of the likelihood of possible jamming and food continuing to spill into the bowl. The most viable option is to utilize the patented paddle wheel that is used in numerous dry food dispensing application across the market.

## 5.4 Scale Design

Now that the weight capacity of the load cell and the ADC was chosen, the overall design of the base and circuitry will be discussed in this section. First the load cell needs to be set up. An example of how the load cell should be placed in between to plates is shown below.

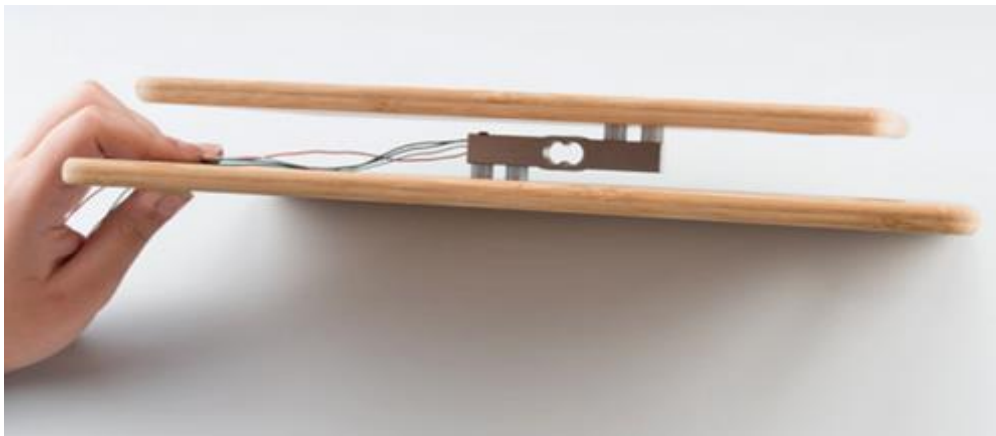

**Figure 68: Load Cell**

The actual base that will be incorporated in the design will be either 3-D printed with either ABS filament or PLA filament or a custom-made plexiglass base will be made. If the surface is perfectly flat and provides a stable surface for the food to be weighed, then the load cell will be able to give off accurate readings to the ADC module. By making a custom design it gives the project flexibility to allow calibration of the system when necessary. The load cell comes with four color wires: red, green, white and black. They each stand for a specific purpose. The red wire will represent VCC, the green wire represents the negative output terminal, the black wire will be the ground and the white wire will be the positive output terminal. These four wires will be connected in the Wheatstone bridge formation as shown in the image below.

The Wheatstone bridge circuit is used to measure unknown resistance values and most importantly it is used for calibration purposes which will be essential to the scale since the base will be custom made. There are different ways to configure Wheatstone bridges: quarter bridge, full-bridge and half bridge. The amount of resistive legs will finally determine which configuration would be beneficial for the scale.

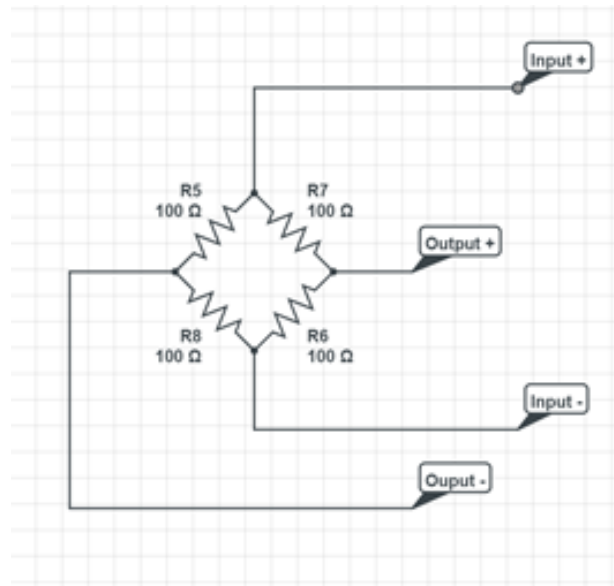

**Figure 69: Wheatstone Bridge Configuration**

It is made of resistor parallel voltage divider circuit configurations that are connected between a voltage supply terminal and ground which results in a zero-voltage difference between the two parallel branches [56]. Once these wires are connected to the ADC module, the module can be connect to the VDD, VCC, DAT,CLK and GRD to the PCB controller board [52]. Using custom code, the weight sensor can now be calibrated based on the setup desired.

## 5.5 Enclosure Design

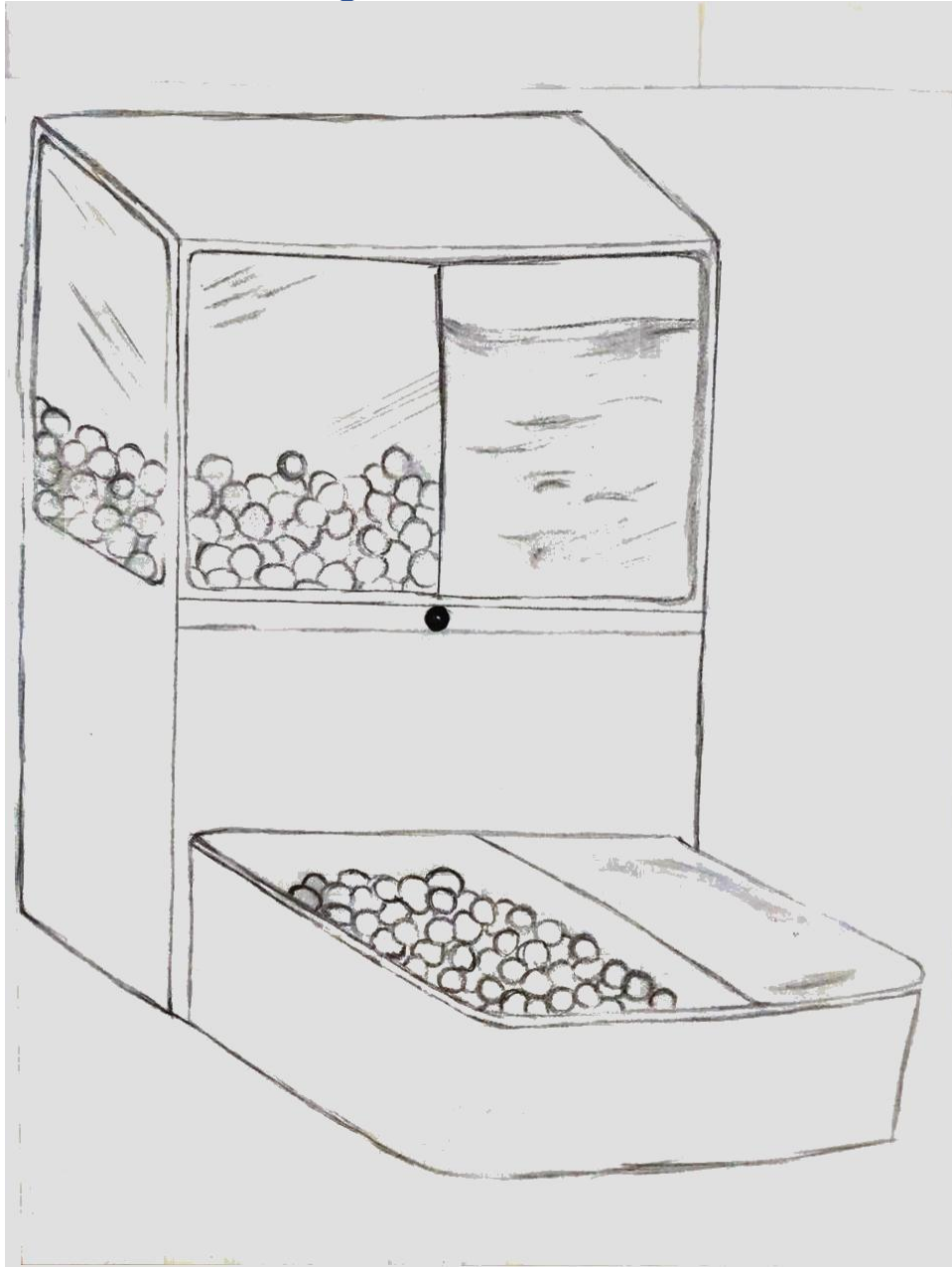
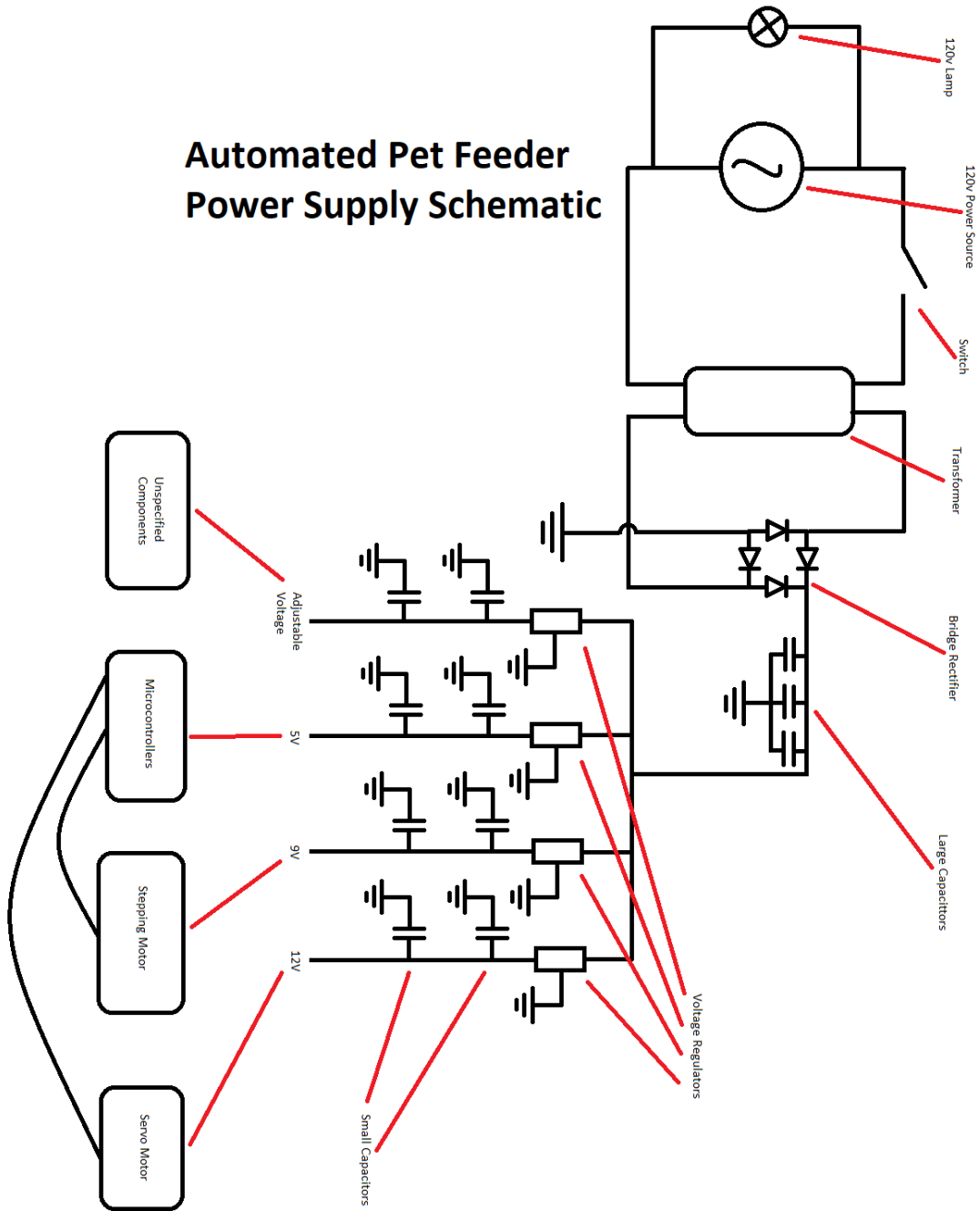

**Figure 70: Enclosure Design**

## 6 System Testing

### 6.1 Overall Integration

Our team has currently tested the main major components to see if the components function as they were supposed to. The phase consisted of designing and building the power supply circuit that involved using a 12V transformer, capacitors, voltage regulators and a custom-built bridge rectifier. Next component to test is the microcontroller to see if it works. Once that is functioning the major component to test is the DC motor. In order to test this motor that will turn the paddle to dispense food, our team went to the Senior Design lab and used the power supply provided there. Detailed description of how each component was tested will be described in the following sections of this section.



**Figure 71: Overall Schematic - Designed and Created by Malcolm Morgan**

## 6.2 Power Supply Testing

While the design of the Automated Pet Feeder holds its importance, this design would not be able to be fabricated without extensive testing of the several parts used in the construction of the Automated Pet Feeder. The Automated Pet Feeder is comprised of several parts, however, as some parts are precursors to others, whether through providing data or signals, this ultimately renders it impossible to test all parts at once. Therefore, it was determined to test the parts that would be developed initially, which included the power supply, several motors, microcontrollers, and software to power the microcontrollers.

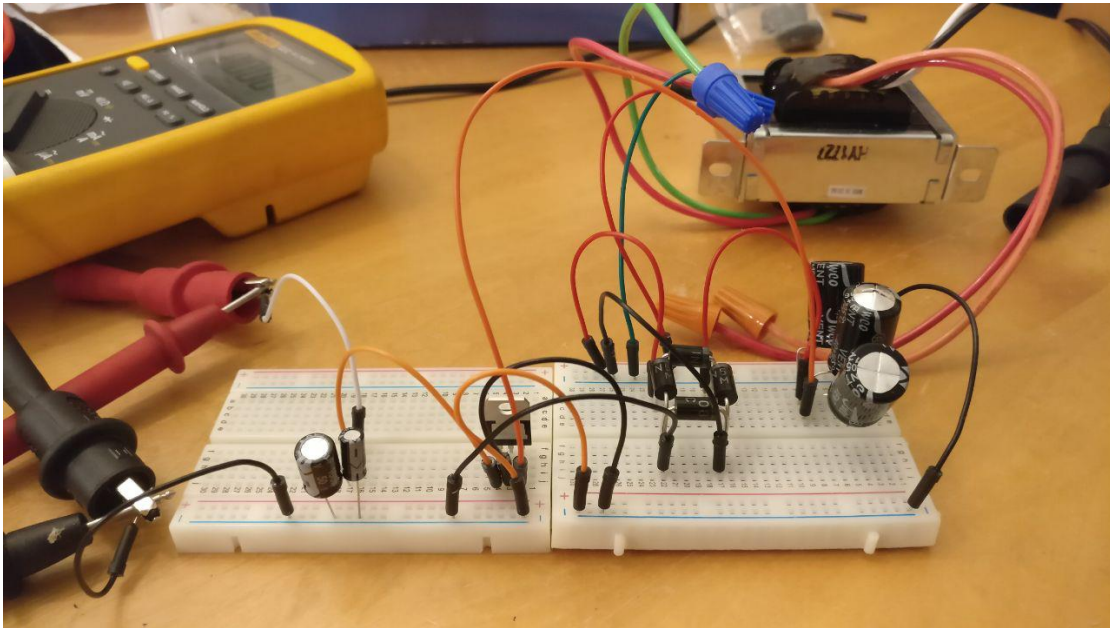

**Figure 72: Testing the Power Supply**

The power supply of the Automated Pet Feeder was subjected to several tests to verify that it functioned correctly. As the power supply is responsible for supplying current at several specified electric potentials, a complex set of requirements were set to ensure that it did not pose a risk to the additional components. The testing of the power supply began by referencing the schematic that was designed, and implementing the components found on the schematic onto a breadboard. The first component that was placed into the leads on the breadboard was the bridge rectifier. The bridge rectifier was constructed by placing 4 diodes in the configuration determined from the design implemented on the schematic onto the breadboard, making sure to bend the leads and place them into the correct leads that were in series on the breadboard. This configuration transformed the incoming alternating current signal into a rectified signal. Next, a capacitor bank was created with 3 2200uf 25V capacitors, placed in parallel onto the breadboard, which culminated in the summation of their capacitance being the overall capacitance of the capacitor bank. It was also made sure that the negative terminal of the capacitors in the capacitor band fed into the ground of the circuit, as the possibility of a capacitor exploding was apparent if this precaution was not in place. This configuration

and purpose of the capacitors were to provide additional current that compensated for the drop in current when the rectified signal was in decline. Thus, the resulting signal was a relatively constant direct current signal. Next, the direct current signal was fed into a L7805 voltage regulator. The L7805 voltage regulator is rated at a maximum input voltage of 35 volts and a minimum input voltage of 7 volts. The L7805 voltage regulator can allow a throughput of up to 1 ampere, and has a specified output voltage of 5 volts. This configuration and purpose of the L7805 voltage regulator was to give an output voltage of 5 volts. Lastly, two smoothing capacitors, 10uf and 100uf, were added in series after the voltage regulator, which smoothed out any possible drops in the direct current signal that may occur depending on the load. This was the final configuration of the several parts placed onto the breadboard, however, the step-down transformer was still needed to convert the incoming 120 volts alternating current signal into a signal with a lower voltage. The transformer used stepped down the incoming signal from 120 volts to 24 volts, which was then supposed to be manageable by the capacitor bank, as the capacitors in the capacitor bank had a specified maximum input voltage of 25 volts. This, however, proved not to be true, as a capacitor in the capacitor bank exploded within a minute of providing a power source to the circuit.



**Figure 73: Blown Capacitor**

Two weeks later, testing continued, though it was decided to test the voltage being produced at every point in the circuit to determine why one of the capacitors previously used blew, although the voltage fed into the capacitor was 1 volt below the maximum specified input voltage. Therefore, a fluke was used to determine and verify the voltage being produced from the output terminals of the step-down transformer. Once configured to VAC, the fluke's reading was recorded, and it was noted that the step-down transformer did, in fact produced 24 volts from its output terminals. Once again, another node of the circuit was under investigation, with this part being the output of the diodes that were configured to make a bridge rectifier. The fluke was then configured to VDC, and used to test the terminals of the output of the bridge rectifier. The fluke confirmed that the bridge

rectifier produced a rectified, 24 volts, direct current signal, albeit not smooth. The design was then altered once more to compensate for the issue previously experienced, but with a high tolerance. It was decided that this time, a capacitor bank was used that contained an assortment of capacitors, though all capacitors in the new capacitor bank were rated at a maximum input voltage of 50 volts. Again, the power source for the circuit was resumed, and after several second of the circuit being turned on, one of the smaller capacitors in the capacitor bank blew. At this point, it was concluded that it would be best to utilize as few parts as possible to limit the possibility of errors in the configuration, therefore the capacitor bank was reconstructed with only 3 capacitors rated at 50 volts. Once the power source was resumed, the fluke was used to determine the voltage at the output terminal of the capacitor bank, and it was surprisingly observed that the voltage was 50 volts. As this was not the expected outcome, the power source was quickly disconnected, as to not blow an additional capacitor. Additional ideas were expressed as to what could be causing the voltage to spike, and resulting in the failure of the capacitors. It was thought that multiple capacitors may contribute to an increase in electric potential, though it was observed through yet again using the fluke that the voltage at the output terminal of a single capacitor, rated at 50 volts, was 38 volts. While it was ultimately not determined why the voltage was being increased by the capacitor bank, and even by a single capacitor, a theory was express that the fundamental issue being faced may be related to the fact that the voltage at the output of the step-down transformer is a peak-to-peak signal, while the voltage at the output terminal of the capacitor bank is a smooth, direct signal. This theory, however, remains not fully tested, as the schematic of the power supply for the Automated Pet Feeder is currently being redesigned to address the previously discussed issue.

## 6.3 Microcontroller and Motor Testing

Several motors and microcontrollers are utilized to fulfill the desired functions of the Automated Pet Feeder, for instance, closing the door to the food storage area, dispensing food, and the processing power behind said functions. It was decided to utilize a servo motor for food dispensation, and a stepper motor for the closing and opening functionality of the door. An Arduino Uno microcontroller in conjunction with a Deek Robot motor shield was used to control the servo motor, and a 12 volts direct current voltage power supply was used to provide additional current to the servo motor. Sample code from the manufacture of the motor shield was downloaded, compiled, and imported onto the Arduino Uno. After modifying the sample source code so that the motor consistently performed at maximum capacitor, it was observed that the motor drew below one ampere of current, and thus fell within the current rating of the voltage regulators that would be used. Below is a successful System Test of the DC motor.



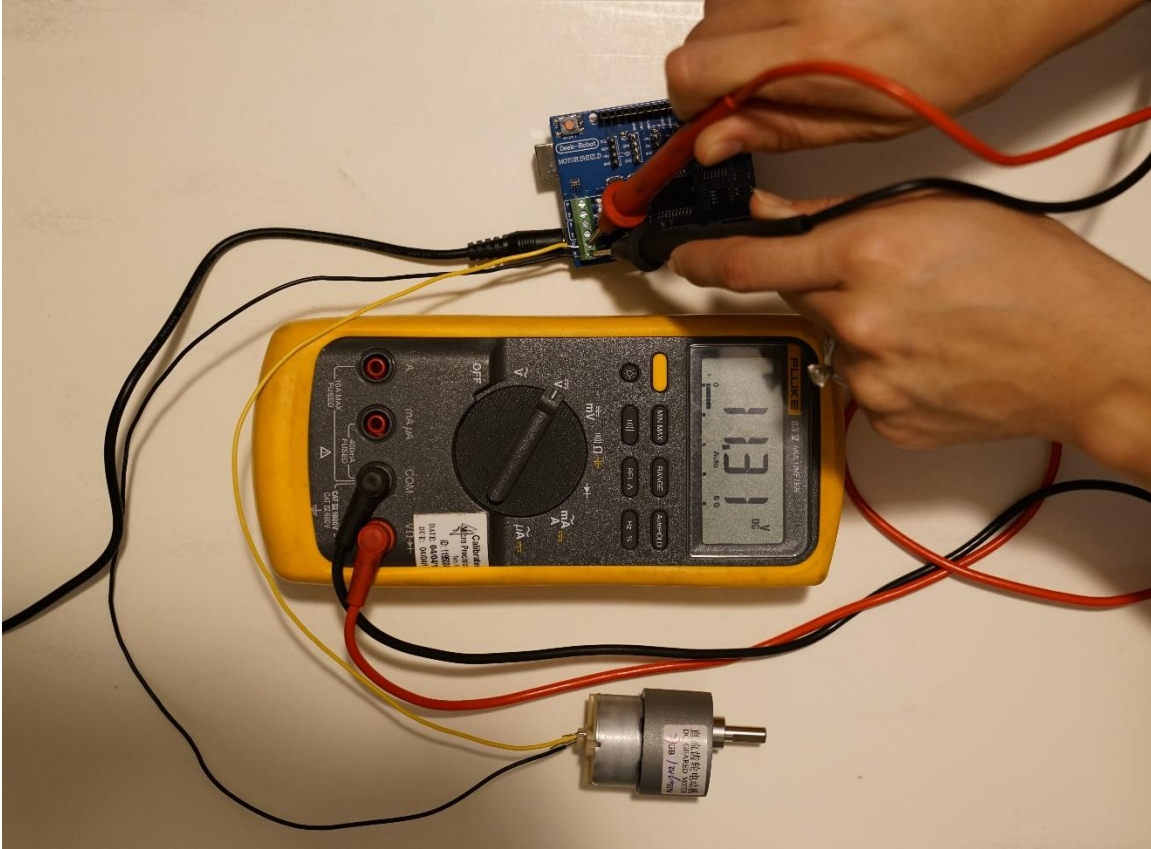

Figure 74: Microcontroller and Motor Testing

## 7 Administration

### 7.1 Milestone Discussion

At the beginning of Senior Design 1, our class was encouraged to start planning for a time line of how the project was going to get accomplished. The advisors called these tasks milestones. In our Project Description Section, our team discussed what our goals were week by week. After 15 weeks, component comparisons were made, testing how to build the power supply, testing the motors and agreeing on a design for the enclosure. Giving ourselves, sufficient amount of time helped our team become more organized and more was accomplished than we had planned to complete. The skills our team has picked up during these 15 weeks not only translates into this project but also in everyday life and work. Having excellent organizational skills is crucial in work environment and at all times lauded. By having the design of the enclosure decided, our team is now able to organize how the PCB design would be the most beneficial in the custom-built enclosure. Below shows the progress made in our team's milestones

**Table 6 – Project Milestones**

Deliverable	Customer	Due Date/Milestone	Length of Time to Complete?	Steps to Completion	Status
10 Page Paper	SD Advisors	9-22-2017	2 - Weeks	Divide and Conquer	Completed
Material List	SD Advisors	9-29-2017	1 - Week	Research What is Needed	Completed
Prototype Draft	Team	9-29-2017	1 - Week	Each Member Design a Draft	Researching
Budget Draft	Team/SD Advisors	9-22-2017	2 - Weeks	Compare Similar Items	Re-analyzing
Schematic	Team/SD Advisors	10-6-2017	2 - Weeks	Solidworks	Schematic
App Options	Team/SD Advisors	11-17-2017	6 - Weeks	Research SW Options	Researching
Buy Materials	Team/SD Advisors	10-13-2017	1 - Week	Order Parts	Completed
Finish 90 Page Report	Advisors	12-01-2017	12 - Weeks	Divide and Conquer	Completed

### 7.1.1 Budget Analysis

Our team is at the point where we have to re-analyze the proposed budget of 154 dollars. Our teams still have to consider the cost of sending out the final PCB design. Our team has reanalyzed the budget to be 200 dollars which would include sending out the PCB design and any maintenance that may occur for replacement parts. Below is the updated cost of the project and the total is subject to change.

**Table 7: Parts Bought**

Item	Quantity	Price
Camera	1	\$9.99
Motors	3	\$50
PCB	1 (one pack = 30)	\$10.86
RFID	2	\$27.97
Weight Scale	1	\$8.50
Switch	1	\$5.12
Transformer	1	\$12.90
Power Supply	1	\$27.91
Neon Light	1 (pack)	\$5.88
Total:		\$159.15

## 8 Conclusion

In the end, our team wants to provide pet owners with a fun and safe way for their pet to access their food in a healthy manner and take out the hassle of measuring food and overfeeding. The Automated Pet Feeder is great for when the owner has multiple pets they want to feed. Now they do not have to worry about one pet stealing the other's food. Concerned that you might not be on time to feed your pet? With the simple and easy to use app, the pet owner was simply click on the mobile application and allow you pet to eat remotely. As pet owners, we understand the frustration on these certain problems and with the Automated Pet Feeder, these past issues or concerns are now solved.

Throughout this project, our team has worked diligently together on research and designing but that is not what we only learned. We learned how to work as a team. It might sound trivial but working around each other schedules and completing the work was a task in itself. In the real world, you will be working with a team of people and learning to work with different types of personalities is a must in any workplace. Luckily, we have a team that is hard working and we are knowing that we will have a productive Senior Design Semester.

## 9 Appendix

### 9.1 References

- [1] Number of dogs in the U.S. Retrieved September 21, 2017, from <https://www.statista.com/statistics/198100/dogs-in-the-united-states-since-2000/>
- [2] U.S. and World Population Clock Tell us what you think. (n.d.). Retrieved September 22, 2017, from <https://www.census.gov/popclock/>
- [3] EasyFeed Automatic Pet Feeder w/ Webcam and Amazon Delivery. (n.d.). Retrieved September 22, 2017, from <https://www.kickstarter.com/projects/1214906246/gosh-easyfeed-the-100-hassle-free-automatic-pet-fe>
- [4]“DC Motors | Direct Current | Brushed | Brushless| Distributor.” ISC Companies, <https://isccompanies.com/company/associations/>
- [5]Gill, Hurley. “How Do Stepper Motor Work?” *Explain That Stuff*, 21 Jan. 2017, <http://www.explainthatstuff.com/how-stepper-motors-work.html>
- [6] Reed, Frances. “How Do Servo Motors Work”. *How Servo Motors Work*, <https://www.jameco.com/jameco/workshop/howitworks/how-servo-motors-work.html>
- [7] Lamp Panel Yellow Neon <https://www.jameco.com/Jameco/Products/ProdDS/215812.pdf>
- [8] Types of Printed Circuit Boards <https://www.elprocus.com/different-types-printed-circuit-boards/>
- [9] Switches <https://learn.sparkfun.com/tutorials/switch-basics/poles-and-throws-open-and-closed>
- [10] Specific Switch <https://flipelectrical.com/products/baomain-toggle-switch-spst-on-off-2-position-250vac-15a-125vac-20a-1-2-mounting-hole-screw-terminal>
- [11] Transformer reference <https://www.allaboutcircuits.com/textbook/alternating-current/chpt-9/step-up-and-step-down-transformers/>
- [12] Lieu, John. “Are Your Dog’s Food Bowls Safe? A Pet Bowl Materials Guide.” *Bark Think*, 9 July 2014 <http://barkthink.com/dogs-food-bowls-safe/>

- [13] Miller, Jim. "Brushless Motors vs Brush Motors, What's the Difference?" *Quantum Devices, Inc.*, 27 Aug. 2010, [www.quantumdev.com/brushless-motors-vs-brush-motors-whats-the-difference/](http://www.quantumdev.com/brushless-motors-vs-brush-motors-whats-the-difference/).
- [14] Specific Transformer Used  
<http://www.packardonline.com/Shop/PrintProduct/5716>
- [15] "AquaPlumb® - Water Level Sensors." *Water Level Sensor*, 2008, [www.vegetronix.com/Products/AquaPlumb/](http://www.vegetronix.com/Products/AquaPlumb/).
- [16] Sam, Techy, and Instructables. "How to Make a Simple Water Level Indicator." *Instructables.com*, Instructables, 19 Sept. 2017, [www.instructables.com/id/How-to-Make-a-Simple-Water-Level-Indicator-1/](http://www.instructables.com/id/How-to-Make-a-Simple-Water-Level-Indicator-1/).
- [17] Piek, Lauren. "Pedestal v. Submersible Sump Pump." *Blain's Farm & Fleet Blog*, 18 June 2015, [www.farmandfleet.com/blog/pedestal-v-submersible-sump-pump/](http://www.farmandfleet.com/blog/pedestal-v-submersible-sump-pump/).
- [18] 370S series DC motor data sheet  
<https://www.transmotec.se/wp-content/uploads/2017/05/Transmotec-DC-Motors-0.1W-200W-eng-F.pdf>
- [19] Diodes generic  
<https://www.allaboutcircuits.com/textbook/semiconductors/chpt-3/introduction-to-diodes-and-rectifiers/>
- [20] Full Wave Rectifier  
[http://www.electronics-tutorials.ws/diode/diode\\_6.html](http://www.electronics-tutorials.ws/diode/diode_6.html)
- [21] Wikipedia. Radio-frequency Identification, November 2017  
[https://en.wikipedia.org/wiki/Radio-frequency\\_identification](https://en.wikipedia.org/wiki/Radio-frequency_identification)
- [22] IMPNJ. "Types of RFID Systems", November 2017  
<https://www.impnj.com/about-rfid/types-of-rfid-systems/>
- [23] Technology Solutions. "RFID Comparisons", November 2017  
<https://www.tsl.com/support/rfid-comparison/>
- [24] SainSmart. Mifare RFID-RC522 IC Card Reader Module, November 2017  
<https://www.sainsmart.com/products/mifare-rfid-rc522-ic-card-reader-module>
- [25] Chafon. Mini USB-key 13.56Mhz card reader, November 2017  
<http://www.chafon.com/productdetails.aspx?pid=367>

- [26] ID-Innovations. "ID-2/12/20 LA Series Datasheet X1", November 2013  
<https://cdn.sparkfun.com/datasheets/Sensors/ID/ID-2LA,%20ID-12LA,%20ID-20LA2013-4-10.pdf>
- [27] Amazon. Keyestudio Camera Module 5MP REV 1.3 for Raspberry Pi 3 Model B Pi 2,  
November 2017  
<https://www.amazon.com/Keyestudio-Raspberry-Camera-Module-5MP/dp/B073RCXGQS>
- [28] OmniVision. "OV5647 5-Mega Pixel Product Brief", November 2010  
<http://docs-europe.electrocomponents.com/webdocs/11d1/0900766b811d1155.pdf>
- [29] SparkFun. "Getting Started with Load Cells", November 2017  
<https://learn.sparkfun.com/tutorials/getting-started-with-load-cells>
- [30] SparkFun. SparkFun Load Cell Amplifier - HX711. November 2017  
<https://www.sparkfun.com/products/13879>
- [31] Schottky Diode  
<http://www.futureelectronics.com/en/diodes/schottky-diodes.aspx>
- [32] Fast Recovery Diode  
<http://www.learningaboutelectronics.com/Articles/Fast-recovery-diode.php>
- [33] 1N5408 Diode  
[https://www.amazon.com/gp/product/B01M7S2ROI/ref=oh\\_aui\\_search\\_detailpage?ie=UTF8&psc=1](https://www.amazon.com/gp/product/B01M7S2ROI/ref=oh_aui_search_detailpage?ie=UTF8&psc=1)
- [34] Capacitors  
<https://learn.sparkfun.com/tutorials/capacitors>
- [35] Specific Capacitors Used  
[https://www.amazon.com/gp/product/B00UJDJEAU/ref=oh\\_aui\\_search\\_detailpage?ie=UTF8&psc=1](https://www.amazon.com/gp/product/B00UJDJEAU/ref=oh_aui_search_detailpage?ie=UTF8&psc=1)
- [36] Voltage Regulators  
<https://www.lifewire.com/types-of-voltage-regulators-818851>
- [37] Specific Voltage Regulators  
[https://www.amazon.com/gp/product/B074FPVSWR/ref=oh\\_aui\\_search\\_detailpage?ie=UTF8&psc=1](https://www.amazon.com/gp/product/B074FPVSWR/ref=oh_aui_search_detailpage?ie=UTF8&psc=1)
- [38] Wikipedia. Ultra High Frequency, November 2017

[https://en.wikipedia.org/wiki/Ultra\\_high\\_frequency](https://en.wikipedia.org/wiki/Ultra_high_frequency)

[39] Wikipedia. High Frequency, November 2017

[https://en.wikipedia.org/wiki/High\\_frequency](https://en.wikipedia.org/wiki/High_frequency)

[40] Wikipedia. LowFrequency, November 2017

[https://en.wikipedia.org/wiki/Low\\_frequency](https://en.wikipedia.org/wiki/Low_frequency)

[41] RFID Vs. NFC

<https://blog.atlasrfidstore.com/rfid-vs-nfc>

[42] Raspberry Pi Camera Module

<https://blog.atlasrfidstore.com/rfid-vs-nfc>

[43] Arducam. "Sony IMX219", November 2017

<http://www.arducam.com/8mp-sony-imx219-camera-raspberry-pi/>

[44] Wikipedia. S-Mount (CCTV), November 2017

[https://en.wikipedia.org/wiki/S-mount\\_\(CCTV\\_lens\)](https://en.wikipedia.org/wiki/S-mount_(CCTV_lens))

[45] Wikipedia. Field of View, November 2017

[https://en.wikipedia.org/wiki/Field\\_of\\_view](https://en.wikipedia.org/wiki/Field_of_view)

[46] Wikipedia. Depth of Field, November 2017

[https://en.wikipedia.org/wiki/Depth\\_of\\_field](https://en.wikipedia.org/wiki/Depth_of_field)

[47] Arducam. "Motorized Cut IR Filter", November 2017

<http://www.arducam.com/arducam-noir-raspberry-pi-camera-motorized-ir-cut-filter/>

[48] Arducam. "Raspberry Pi Camera Rev C", November 2017

<http://www.arducam.com/raspberry-pi-camera-rev-c-improves-optical-performance/>

[49] Arducam. "Spy Camera", November 2017

<http://www.arducam.com/spy-camera-raspberry-pi/>

[50] Noshok. "Hydraulic Load Cell Overview", November 2017

[http://www.noshok.com/reference\\_hydraulic\\_load\\_cell.shtml](http://www.noshok.com/reference_hydraulic_load_cell.shtml)

[51] Omega. "Introduction to Load Cells", November 2017

<https://www.omega.com/prodinfo/loadcells.html>

[52] Load Cell Amplifier – HX711

<https://learn.sparkfun.com/tutorials/load-cell-amplifier-hx711-breakout-hookup-guide>

[53] Analog to Digital Conversion

<https://learn.sparkfun.com/tutorials/analog-to-digital-conversion>



[54] Mouser Electronics. "24-Bit Analog-to-Digital Converter (ADC) for Weigh Scales", November 2017

[http://www.mouser.com/ds/2/813/hx711\\_english-1022875.pdf](http://www.mouser.com/ds/2/813/hx711_english-1022875.pdf)

[55] Texas Instruments. "ADS1231 Features", November 2017

<http://www.ti.com/product/ADS1231#features>

[56] Wheatstone Bridge

<http://www.electronics-tutorials.ws/blog/wheatstone-bridge.html>

[57] PostgreSQL

<https://www.postgresql.org/about/>

[58] MySQL

<https://www.mysql.com/why-mysql/>

[59] FireBird

<http://www.firebirdsql.org/en/features/>

[60] RASPIAN

<http://www.raspberrypi.org/operating-system-s/item/116-software-os-raspbian>

[61] RICS OS PI

<http://www.riscos.com/riscos/600/index.php>

[62] Allaboutcircuits. "Introduction to Capacitive Touch Sensing". November 2017

<https://www.allaboutcircuits.com/technical-articles/introduction-to-capacitive-touch-sensing/>

[63] Wikipedia. Capacitive Sensing, November 2017

[https://en.wikipedia.org/wiki/Capacitive\\_sensing](https://en.wikipedia.org/wiki/Capacitive_sensing)

[64] Wikipedia. Inductive Sensor, November 2017

[https://en.wikipedia.org/wiki/Inductive\\_sensor](https://en.wikipedia.org/wiki/Inductive_sensor)

[65] Magnetic Proximity Sensors

[http://www.globalspec.com/learnmore/sensors\\_transducers\\_detectors/proximity\\_presence\\_sensing/proximity\\_presence\\_sensors\\_magnetic\\_types](http://www.globalspec.com/learnmore/sensors_transducers_detectors/proximity_presence_sensing/proximity_presence_sensors_magnetic_types)

[66] Heftener, Armin. "How Precise are Sonar Proximity Switches" Simatic Sensors, 2005

[http://www.automation.siemens.com/simaticensorsstatic/ftp/wp\\_px\\_ultra\\_genauigkeit\\_e.pdf](http://www.automation.siemens.com/simaticensorsstatic/ftp/wp_px_ultra_genauigkeit_e.pdf)

- [67] Ultrasonic Proximity Sensor  
[http://www.globalspec.com/learnmore/sensors\\_transducers\\_detectors/proximity\\_presence\\_sensing/ultrasonic\\_proximity\\_sensors](http://www.globalspec.com/learnmore/sensors_transducers_detectors/proximity_presence_sensing/ultrasonic_proximity_sensors)
- [68] Proximity Sensor HC SR04  
<https://cdn.sparkfun.com/datasheets/Sensors/Proximity/HCSR04.pdf>
- [69] Proximity Sensor APDS9960  
<https://cdn.sparkfun.com/datasheets/Sensors/Proximity/apds9960.pdf>
- [70] MaxSonar-EZ  
[https://www.maxbotix.com/documents/HRLV-MaxSonar-EZ\\_Datasheet.pdf](https://www.maxbotix.com/documents/HRLV-MaxSonar-EZ_Datasheet.pdf)
- [71] IMPINJ. "RFID Standards", November 2017  
<https://www.impinj.com/about-rfid/rfid-standards/>
- [72] Number of Application on Google Play Store  
<https://www.statista.com/statistics/266210/number-of-available-applications-in-the-google-play-store/>
- [73] Components of the Graphical User Interface  
[https://www.webopedia.com/TERM/G/Graphical\\_User\\_Interface\\_GUI.html](https://www.webopedia.com/TERM/G/Graphical_User_Interface_GUI.html)
- [74] History of the Computer Mouse  
<http://www.computinghistory.org.uk/det/613/the-history-of-the-computer-mouse/>
- [75] Mouse Figure  
<https://www.lifewire.com/what-is-a-mouse-2618156>
- [76] Pointer Figure  
<https://www.computerhope.com/issues/ch001618.htm>
- [77] Desktop Figure  
<https://www3.lenovo.com/in/en/desktops-and-all-in-ones/c/DESKTOPS>
- [78] Menu Figure  
<https://www.askvg.com/add-system-tools-cascading-menu-in-my-computer-context-menu-in-windows-7/>
- [79] World Electricity Standards  
<https://www.quantumbalancing.com/worldelectricity/electricityif.htm>
- [80] ISO/IEC 18000-63:2013  
<https://www.iso.org/standard/59643.html>
- [81] User Interface Definition

<https://www.usability.gov/what-and-why/user-interface-design.html>

[82] Icon Figure

<https://www.flaticon.com/>

[83] Windows Figure

<https://www.windowscentral.com/how-remove-onedrive-file-explorer-windows-10>

[84] Qureshi, Asim. "10 Best Motor Drivers For Arduino." Wonderful Engineering, 21 Jan. 2016.

<http://www.wonderfuleengineering.com/10-best-motor-drivers-for-arduino/>

[85] "Polylactic Acid (PLA) Bioplastic: The Pros and Cons | Biomass Packaging." BioMass Packaging | Sustainable Foodservice Solutions, 13 July 2015,

[www.circuitdigest.com/electronic-circuits/laser-security-alarm-circuit-diagram](http://www.circuitdigest.com/electronic-circuits/laser-security-alarm-circuit-diagram).

[86] "Polylactic Acid (PLA) Bioplastic: The Pros and Cons | Biomass Packaging." BioMass Packaging | Sustainable Foodservice Solutions, 13 July 2015,

[www.biomasspackaging.com/the-pros-and-cons-of-polylactic-acid-pla-bioplastic-the-corn-plastics/](http://www.biomasspackaging.com/the-pros-and-cons-of-polylactic-acid-pla-bioplastic-the-corn-plastics/)

[87] MatterHackers. "How to Succeed When 3D Printing With Nylon." MatterHackers, 23 Sept. 2014,

[www.matterhackers.com/articles/printing-with-nylon](http://www.matterhackers.com/articles/printing-with-nylon)

## 9.2 Table of Figures

Figure 1: FunPaw Automated Pet Feeder. Bottom left: Petnet SmartFeeder. Bottom right: Petmate Portion Right Programmable Pet.....	8
Figure 2: Pet Populations in the USA .....	10
Figure 3: Example of AC power supply.....	13
Figure 4: Double Sided Printed Circuit Board.....	13
Figure 5: Multilayer Printed Circuit Board .....	14
Figure 6: Different Types of Switches .....	15
Figure 7: Baomain Toggle switch SPST.....	16
Figure 8: Lamp Panel Yellow Neon 120VAC Solder Terminals with Bulb Datasheet .....	17
Figure 9: Step-Down Transformer.....	18
Figure 10: Packard PF42440 Control Transformer Class II Foot Mount Datasheet .....	19
Figure 11: Hydraulic check valve analogy: (a) Electron current flow permitted. (b) Current flow prohibited .....	20
Figure 12: Full Wave Rectifier .....	20
Figure 13: Fast Recovery, Rectifier, & Schottky Diodes.....	21
Figure 14: 1N5408 Data Sheet .....	23
Figure 15: Capacitor Construction .....	24
Figure 16: Capacitance Equation.....	24
Figure 17: Electron Representation in a Capacitor.....	25
Figure 18: Ceramic, Electrolytic, & Supercapacitors .....	26
Figure 19: Voltage Drop Across Several Resistors.....	28
Figure 20: Linear, Switching, and Zener Diode Voltage Regulators.....	28
Figure 21: L78 Series Voltage Regulator Datasheet .....	29
Figure 22: Blueprint for a tambour door application .....	31
Figure 23: Typical Servo Motor (top left), Typical Stepper Motor (top right), Typical DC Motor (bottom).....	32
Figure 24: Example of Brushed and Brushless DC Motors .....	33
Figure 25: 470S Series Specifications .....	35
Figure 26: SainSmart L293D Motor Drive Shield .....	37
Figure 27: DROK L298N Motor Drive Controller .....	38
Figure 28: Example of a Brushless Submersible Water Pump.....	39
Figure 29: Example of a Pedestal Sump style water pump. ....	39
Figure 30: Right angle float sensor.....	40
Figure 31: Example of a water monitoring system circuit.....	41
Figure 32: All in one water level monitor by AquaPump.....	41
Figure 33: Example of implementation of float sensor monitoring .....	42
Figure 34: Laser Security Alarm Circuit .....	43
Figure 35: Example of stainless steel bowls. ....	44
Figure 36: High Frequency RFID (top left), Low Frequency RFID (top right) NFC Tag (bottom).....	47
Figure 37: High Frequency RFID Tag Specifications.....	48
Figure 38: High Frequency Scanner (left), NFC Scanner(top right) and High Frequency USB Reader (bottom left) .....	49
Figure 39: Low Frequency Scanner (left) and Low Frequency USB Reader (right) .....	50
Figure 40: Mifare RFID-RC522c IC Card Reader Module Specifications .....	51
Figure 41: Chafon 13.56MHZ USB HF RFID Mifare IC Card Reader Specifications.....	51
Figure 42: Spy Camera(right), Pi Camera Module (bottom) and Rev.C (right) .....	52
Figure 43: Sony IMX219 Camera .....	53

## Automated Pet Feeder

Figure 44: Raspberry Pi Camera Module 5MP REV 1.3 .....	54
Figure 45: Examples of Different Load Cells.....	56
Figure 46: Breakdown of Strain Gauge Load Cell .....	57
Figure 47: HX711 ADC Converter Breakout Module .....	58
Figure 48: HX711 ADC Converter Breakout Module Specifications .....	59
Figure 49: Ultrasonic Range Finder (bottom), HC-SR04 (top right), Gesture Sensor and RBG Finder (top left) .....	61
Figure 50: Specifications of HC-SR04 .....	62
Figure 51: Final Parts Selection.....	63
Figure 52: Raspbian Specification list.....	65
Figure 53: World Wide Power Standards.....	72
Figure 54: Typical datasheet for 3D printing filament.....	73
Figure 55: Example of roles of different 3D printing filament.....	74
Figure 56: Automated Pet Feeder Power Supply Schematic - Design & Created by Malcolm Morgan .....	77
Figure 57: Examples of Different Style Momentary Switches .....	78
Figure 58: Pointer .....	79
Figure 59: Computer Mouse .....	80
Figure 60: Popular Social Media Icons .....	81
Figure 61: Computer Desktop.....	81
Figure 62: Several Windows.....	82
Figure 63: Nested Menus.....	82
Figure 64: Example of Wheel Design for Possible 3-D Printing .....	83
Figure 65: Example of 3-D Printed Plastic Sliding Door .....	83
Figure 66: Patented Rubber Paddle Wheel.....	84
Figure 67: Example Use of Rubber Paddle Wheel in a Cereal Dispenser.....	84
Figure 68: Load Cell.....	85
Figure 69: Wheatstone Bridge Configuration.....	86
Figure 70: Enclosure Design .....	87
Figure 71: Overall Schematic - Designed and Created by Malcolm Morgan .....	89
Figure 72: Testing the Power Supply.....	90
Figure 73: Blown Capacitor .....	91
Figure 74: Microcontroller and Motor Testing.....	93

## 9.3 Copyright

### Contact Details

**Address:**  
Nbe Motors Pvt. Ltd.  
Dikshit Panchal(Director)  
Shed No. 1 To 7, Tirupati Estate, Opposite  
Bombay Housing Milan Road, Saraspur,  
Ahmedabad - 380024, Gujarat, India

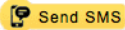
**Call Us:**  
**+91-8079447216** 

**Mobile:**  
+91-9824035406  
+91-9327049213

**Telephone:**  
+91-79-22740546

### Contact Us

 Good afternoon

My name is Hector Rodriguez and I am an electrical engineer at the university of central florida. I'm am requesting permission to use an image of a DC motor from your website for my senior design project. Thank you for your time

Hector Rodriguez

 Rodriguez.L.Hector@hotmail.com

 Hector Luis Rodriguez



### image usage request

 **Hector Rodriguez**  
Today, 2:41 AM  
contact@circuitdigest.com

   Reply | v

Good afternoon

My name is Hector Rodriguez and I am an electrical engineer at the university of central florida. I'm am requesting permission to use an image from your website "Laser Security Alarm Circuit" that was provided by Saddam for my senior design project. Thank you for your time

Hector Rodriguez

## Automated Pet Feeder

### Image usage request



Hector Rodriguez

Today, 1:43 AM

help@webstaurantstore.com



Good afternoon

My name is Hector Rodriguez and I am an electrical engineer at the university of central florida. I'm am requesting permission to use an image of your Automated Pet Feeder from your website for my senior design project. Thank you for your time

Hector Rodriguez

### image usage request



Hector Rodriguez

Today, 2:59 AM

Service@droking.com



Good afternoon

My name is Hector Rodriguez and I am an electrical engineer at the university of central florida. I'm am requesting permission to use an image from your website DROK L298N Motor Drive Controller that was provided by Amazon for my senior design project. Thank you for your time

Hector Rodriguez

### Request use of image



Hector Rodriguez

Today, 12:36 AM

support@petnet.io

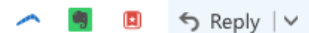

Good afternoon

My name is Hector Rodriguez and I am an electrical engineer at the university of central florida. I'm am requesting permission to use an image of your Automated Pet Feeder from your website for my senior design project. Thank you for your time

Hector Rodriguez

I am requesting permission to use the image of SKU: 101-50-115 for a school project. If there is any issue with the use of this image please notify me at your earliest convenience.

thank you

Hector Rodriguez

SUBMIT

# Automated Pet Feeder

## Image usage request



**Hector Rodriguez**  
Today, 3:06 AM  
support@funpaw.com

Reply |

Good afternoon

My name is Hector Rodriguez and I am an electrical engineer at the university of central florida. I'm am requesting permission to use an image from your website FunPaw automated pet feeder that was provided by Amazon for my senior design project. Thank you for your time

Hector Rodriguez

## inimage usage request



**Hector Rodriguez**  
Today, 10:14 AM  
website@sparkfun.com

Reply |

Good afternoon

My name is Hector Rodriguez and I am an electrical engineer at the university of central florida. I'm am requesting permission to use an image from your website *An assortment of tactile push-button switches* for my senior design project. Thank you for your time

Hector Rodriguez

### Sent Items

Filter

Next: No events for the next two days.

- info@eetech.com  
Request for Use of Image for Senior Design Project Report 9:23 AM  
Hello, I am requesting to use the images on this particular webpage for my group's...
- customerservice@packardonline.com  
Request for Use of Image for Senior Design Project Report 9:21 AM  
Hello, I am requesting to use the images on this particular webpage for my group's...
- info@eetech.com  
Request for Use of Image for Senior Design Project Report 9:14 AM  
Hello, I am requesting to use the images on this particular webpage for my group's...
- sales@jameco.com  
Request for Use of Image for Senior Design Project Report 9:04 AM  
Hello, I am requesting to use the images on this particular webpage for my group's...
- support@flpelectrical.com  
[Request received] Request for Use of Image for Senior Design Project Rep 9:01 AM  
Hello, I am requesting to use the images on this particular webpage for my group's...
- cservice@sparkfun.com  
Request for Use of Image for Senior Design Project Report 8:59 AM  
Hello, I am requesting to use the images on this particular webpage for my group's...
- team@elprocus.com**  
Request for Use of Image for Senior Design Project Report 8:46 AM  
Hello, I am requesting to use the images on this particular webpage for my group's...

### Request for Use of Image for Senior Design Project Report

**Malcolm Morgan**  
Today, 8:46 AM  
team@elprocus.com

Reply all |

Hello,

I am requesting to use the images on this particular webpage for my group's Senior Design project report. Please let me know if this is possible. Thank you.

<https://www.elprocus.com/different-types-printed-circuit-boards/>

-Malcolm A. Morgan



# Automated Pet Feeder

### Sent Items

Filter ▼

Next: No events for the next two days. Agenda

sales@mouser.com  
Request for Use of Image for Senior Design Project Report 10:29 AM  
Hello, I am requesting to use the images on this particular webpage for my group's...

sales@mouser.com  
Request for Use of Image for Senior Design Project Report 10:25 AM  
Hello, I am requesting to use the images on this particular webpage for my group's...

contact@lifewire.com  
Request for Use of Image for Senior Design Project Report 10:21 AM  
Hello, I am requesting to use the images on this particular webpage for my group's...

website@sparkfun.com  
Request for Use of Image for Senior Design Project Report 10:18 AM  
Hello, I am requesting to use the images on this particular webpage for my group's...

sales@mouser.com  
Request for Use of Image for Senior Design Project Report 10:16 AM  
Hello, I am requesting to use the images on this particular webpage for my group's...

team@elprocus.com  
Request for Use of Image for Senior Design Project Report 10:12 AM  
Hello, I am requesting to use the images on this particular webpage for my group's...

### Request for Use of Image for Senior Design Project Report

 Malcolm Morgan  
Today, 10:12 AM  
team@elprocus.com ✉

👍 🔄 Reply all ▼

Hello,

I am requesting to use the images on this particular webpage for my group's Senior Design project report. Please let me know if this is possible. Thank you.

<https://www.elprocus.com/types-of-diodes-and-applications/>  
<https://www.elprocus.com/rectifier-diode-working-applications/>  
<https://www.elprocus.com/schottky-diode-working-and-applications/>

-Malcolm A. Morgan