

UCF Senior Design Spring 2024

Grid Stabilizing Frequency Detector (GSFD)



*Department of Electrical Engineering and Computer Science
University of Central Florida
Dr. ChungYong Chan*

Group: 32

Eric M. Doolin - Electrical Engineering

Alex E. Cruz - Computer Engineering

Aymes Glidewell - Electrical Engineering

Briggs Green - Electrical Engineering

Sponsors: Dr. Qun Zhou Sun

Dr. Guanyu Tian (Texas A&M Galveston)

Committee:

Dr. Qun Zhou Sun

Dr. Wei Sun

Dr. Mike Borowczak

Table of Contents

1	EXECUTIVE SUMMARY	1
2	PROJECT DESCRIPTION	2
2.1	MOTIVATION	2
2.2	GOALS	2
2.3	OBJECTIVES	3
2.4	PRIOR RELATED WORK	4
2.4.1	<i>SkyCentrics CTA-2045 module.....</i>	<i>4</i>
2.4.2	<i>Gridfriendly™ Water Heater Controller.....</i>	<i>5</i>
2.4.3	<i>Electrical Grid Frequency Meter.....</i>	<i>6</i>
2.5	SPECIFICATIONS	8
2.6	HOUSE OF QUALITY.....	9
2.7	HARDWARE BLOCK DIAGRAM	10
3	RESEARCH	10
3.1	GENERAL RESEARCH ON ELECTRIC WATER HEATERS	10
3.1.1	<i>Electric Water Heater.....</i>	<i>10</i>
3.1.2	<i>Functionality.....</i>	<i>11</i>
3.1.3	<i>High Temperature Limiter Device</i>	<i>11</i>
3.1.4	<i>Thermostats.....</i>	<i>11</i>
3.1.5	<i>Electric Water Heater Schematic</i>	<i>12</i>
3.2	TECHNOLOGY COMPARISON, PARTS COMPARISON AND SELECTION	13
3.2.1	<i>Switching Mechanism</i>	<i>13</i>
3.2.2	<i>Switching Relay.....</i>	<i>15</i>
3.2.3	<i>Voltage Measurement Methods.....</i>	<i>19</i>
3.2.4	<i>Current Measurement Methods</i>	<i>25</i>
3.2.5	<i>Current Transformer</i>	<i>28</i>
3.2.6	<i>Frequency Measurement Methods.....</i>	<i>32</i>
3.2.7	<i>Temperature Measurement Methods.....</i>	<i>36</i>
3.2.8	<i>Temperature Sensor Selection</i>	<i>39</i>
3.2.9	<i>Circuit Protection.....</i>	<i>40</i>
3.2.10	<i>Communication Channels</i>	<i>45</i>
3.2.11	<i>Analog to Digital Converter</i>	<i>47</i>
3.2.12	<i>Sigma Delta ADC.....</i>	<i>49</i>
3.2.13	<i>Microcontroller.....</i>	<i>51</i>
3.2.14	<i>MSP430.....</i>	<i>53</i>
3.2.15	<i>JTAG Debugger.....</i>	<i>56</i>
3.2.16	<i>Display.....</i>	<i>58</i>
3.2.17	<i>LCD Display Types</i>	<i>61</i>
3.2.18	<i>Power Supply.....</i>	<i>64</i>
4	STANDARDS AND DESIGN CONSTRAINTS	67
4.1	FORM FACTOR	67
4.2	STANDARDS	67

4.3	ELECTRICAL SAFETY STANDARDS (OSHA).....	67
4.3.1	<i>Examination</i>	68
4.3.2	<i>Installation and Use</i>	68
4.3.3	<i>Identification of Disconnecting Mains and Circuits</i>	68
4.3.4	<i>Guarding of Live Parts and Equipment</i>	68
4.3.5	<i>Grounding</i>	69
4.4	ELECTRICAL SAFETY CODES (OSHA).....	69
4.4.1	<i>Equipment and Personal Protection</i>	69
4.4.2	<i>Electromagnetic Compatibility Standards</i>	70
4.5	ELECTRICAL STANDARDS AND CODES (IEEE)	71
4.6	COMMUNICATION STANDARDS.....	72
4.6.1	<i>SPI</i>	72
4.6.2	<i>I2C</i>	74
4.7	STOCHASTIC CONTROLLER CONSTRAINTS FOR FREQUENCY REGULATION	75
4.8	USER INTERACTIVITY AND DATA CONSTRAINTS	79
4.9	CONSUMER CONSTRAINTS.....	80
4.9.1	<i>Utility</i>	81
4.9.2	<i>End User</i>	81
5	COMPARISON OF CHATGPT WITH OTHER SIMILAR PLATFORMS.....	82
5.1	TECH COMPARISON.....	82
5.2	CODE DEBUGGING AND OPTIMIZATION.....	83
5.3	DATA ANALYSIS ASSISTANCE	83
5.4	ALGORITHM IMPLEMENTATION.....	84
5.5	LACK OF CREATIVITY	84
5.6	TEST CASE 1	85
5.6.1	<i>Results</i>	86
6	HARDWARE DESIGN.....	86
6.1	WATER HEATER CONTROL.....	87
6.2	GSFD POWER SUPPLY	87
6.3	GSFD TO LOAD CONNECTIVITY	88
6.4	VOLTAGE STEP-DOWN CIRCUIT	89
6.5	VOLTAGE DATA	90
6.6	CURRENT DATA.....	91
6.7	TEMPERATURE DATA.....	93
6.8	FREQUENCY DATA.....	94
6.9	SUBSYSTEM INTERCONNECTIVITY AND POWER FLOW	96
6.10	HOUSING	98
6.10.1	<i>Construction</i>	98
6.11	SPONSOR CONSIDERATIONS.....	98
7	SOFTWARE DESIGN	99
7.1	SOFTWARE FLOWCHART.....	99
7.2	STOCHASTIC CONTROLLER IMPLEMENTATION	101
7.3	POLLING.....	103

7.4	USE CASE DIAGRAM.....	103
7.5	USER INTERFACE.....	104
7.5.1	<i>State Diagram</i>	107
8	PCB DESIGN	107
8.1	POWER SUPPLY PCB DESIGN.....	107
8.2	ANALOG CIRCUIT AND MICROCONTROLLER PCB DESIGN	108
9	SYSTEM TESTING	110
9.1	HARDWARE TESTING.....	110
9.1.1	<i>Power Supply Circuit</i>	110
9.1.2	<i>Voltage Measurement</i>	110
9.1.3	<i>Current Measurement</i>	111
9.1.4	<i>Temperature Measurement</i>	111
9.1.5	<i>Frequency Measurement</i>	111
9.1.6	<i>SSR Functionality</i>	112
10	ADMINISTRATIVE CONTENT	112
10.1	BUDGET ESTIMATES	112
10.2	BILL OF MATERIALS	114
10.3	MILESTONES.....	114
10.4	WORK DISTRIBUTION	116
11	CONCLUSION	117

Table of Figures

Figure 1: CTA-2045 Device Diagram

Figure 2: Grid Friendly Appliance Chip Retrofitted to Water Heater

Figure 3: Analog Frequency Detector

Figure 4: House of Quality

Figure 5: Hardware Block Diagram

Figure 6: Water Heater Wiring

Figure 7: SPI Communication Interface

Figure 8: I2C Communication Interface

Figure 9: UART Communication Interface

Figure 10: Battery Current vs Charge Time

Figure 11: Daisy-Chained SPI Interface

Figure 12: Stochastic Filter Implementation

Figure 13: Case Study of 60Hz Convergence

Figure 15: GSFD Connectivity

Figure 16: 12V AC to 5V DC Step-down Circuit

Figure 17: Voltage Sensing Circuit

Figure 18: Basic Current Transformer Diagram

Figure 19: Current Transformer Output Circuitry

Figure 20: Zero-Cross Detection circuit Utilizing NPN Transistor

Figure 21: Power Flow Diagram

Figure 22: Housing Design

Figure 23: Software Flowchart

Figure 24: Stochastic Algorithm

Figure 25: Use Case Diagram

Figure 26: User Interface Home Screen

Figure 27: User Interface Info Screen

Figure 28: User Interface Graph Screen

Figure 29: User Interface Away Screen

Figure 30: State Diagram

Figure 31: 5VDC PCB

Figure 32: MSP Breakout PCB

Figure 33: Analog Circuits PCB

Tables

Table 1: Requirements and Specifications

Table 2: Comparison of Switching Mechanisms

Table 3: Solid State Relay Comparison

Table 4: Rectifier Comparison

Table 5: Voltage Measurement Comparison

Table 6: Current Measurement Comparison

Table 7: Current Transformer Comparison

Table 8: Frequency Measurement Methods

Table 9: Temperature Sensor Comparison

Table 10: Temperature Sensor Selection

Table 11: Circuit Protection Comparison

Table 12: ADC Type Comparison

Table 13: ADC Selection

Table 14: Microcontroller Comparison

Table 15: MSP430 Selection

- Table 16: Debugger Comparison
- Table 17: Display Type Comparison
- Table 18: LCD Selection
- Table 19: Plug Socket Comparison
- Table 20: SPI Modes
- Table 21: Budget and Financing
- Table 22: Bill of Materials
- Table 23: Milestones
- Table 24: Work Distribution

1 Executive Summary

The Grid Stabilizing Frequency Detector (GSFD) project represents the potential for a significant advancement in grid-edge technology, aimed at enhancing grid stability using a demand-side controller. This system intelligently manages the power consumption of household water heaters in response to grid frequency fluctuations. The concept emerged so that this product could adopt an advanced stochastic control algorithm developed by Dr. Guanyu Tian and Dr. Qun Zhou Sun. The project was conceived to address the challenges of grid stability, especially with the increasing integration of renewable energy sources, where demand side regulation is the only way to compensate for stresses on the grid. It involves precise real-time measurement of the grid frequency and dynamic load adjustment, contributing significantly to grid stabilization and energy efficiency. The system's successful implementation demonstrates its potential for more applications in various smart grid scenarios, marking a large step forward in modern energy distribution and consumption.

The GSFD system works by measuring the grid's frequency in real-time, utilizing a design process that converts the grid's AC signal into a digital format interpretable by a microcontroller. This process involves a series of steps including signal rectification, conditioning and analog-to-digital conversion, ensuring accurate and reliable frequency measurements.

One of the core innovations of our project lies in the development and implementation of the stochastic control algorithm. This algorithm not only reacts to under- and over-frequency events by adjusting the load, but also in a dynamic manner that mirrors the current frequency to ensure that it always converges to a nominal 60Hz. This stochastic approach is key to preventing synchronized demand responses across the network.

The project faced and overcame several challenges, particularly in the realm of circuit design and finding a way to implement the design on a large enough scale to make a difference in the current monitored frequency. Through iterative design and testing, we achieved a system that responds effectively to frequency deviations using a deadband, providing a proof-of-concept for enhancing the grid's ability to handle variations in supply and demand.

The implementation of the GSFD system using a deadband controller has shown a promising proof of concept. It has demonstrated the potential to significantly improve grid stability, reduce the need for costly power plant generation, and enhance overall energy efficiency, and shown that this device can safely interact with the water heater and has the ability to operate on a large scale. The success of this project paves the way for further innovations in grid management and opens avenues for broader application in various smart grid scenarios.

2 Project Description

2.1 Motivation

The driving force behind our project results from the necessity to manage the issues of grid stability in a landscape marked by an increasing demand for electricity. With a rapidly growing population relying more heavily on electrical power and an increasing shift towards renewable energy sources, the task of preserving grid stability becomes an increasingly important endeavor. Our design concept is a device that enables household water heaters to operate reactively, contributing to the maintenance of grid frequency by helping alleviate the load during periods of stress.

The United States power grid is one of the largest and most complex electrical networks on the planet. Currently, there are many challenges that jeopardize its stability and reliability. A large factor is that the infrastructure was designed and built in the mid 1950's and is now exceeding its intended lifespan. Recent events show that the current infrastructure is vulnerable to failures and intermittent outages. This problem is exacerbated by the integration of renewable energy sources, increased load on the network and rampant overconsumption of modern technologies such as HVAC systems and water heaters. There is an urgent need to address issues that factor into grid instability. This research aims to explore these challenges, their implications, and to propose a solution to help ensure a resilient and reliable power grid in the United States.

Ensuring that the power grid is reliable and stable is important to maintaining a functioning society. The power grid supports vital functions in sectors across the United States such as essential services, public welfare, manufacturing, data centers, safety, public health, and national security.

Essential services rely on grid stability to maintain devices that enable lifesaving equipment. Failure of these systems could have resounding impacts with life-threatening consequences, such as water treatment facilities or hospitals, where reliable power flow ensures that people are provided clean drinking water to the population, and medical equipment reliably works.

The stability of the power grid goes much further than just keeping the lights on in your home. It ensures a functional society, economic prosperity, and the safety of citizens.

2.2 Goals

Basic Goals: For our basic goals, we plan to implement a Frequency Detector to serve as the foundation for our design. This product is designed to detect unstable grid frequency by monitoring the frequency coming into the water heater in real

time and reacting to it based upon the input received. Upon the detection of any deviations from the nominal frequency of 60Hz, the device will promptly initiate the shutdown sequence if the water heater is currently in operation. To ensure fairness and prevent undue inconvenience, we intend to introduce both a deadband system, which will control the frequency of customers' water heater disconnections. We also plan on implementing a water temperature measurement method that will accurately convey the temperature at the top of the tank to the customer. Finally, we plan to incorporate an informative display into the product that will inform homeowners of different details about their appliance such as how many times their water heater has been deactivated by the controller, real-time grid frequency and voltage, current draw of the load and controller, and the water temperature within their water heater.

Advanced Goals: For our advanced goals, we aim to remove the deadband and incorporate the stochastic controller algorithm into our Grid Stabilizing Frequency Detector. This presents a significant challenge because the controller's optimal performance relies on widespread adoption, necessitating installation across a vast number of households, potentially in the thousands, to achieve the desired impact on grid stability, which may present a problem when it comes down to demonstration. However, the idea of demonstrating this product using hardware-in-the-loop testing has been proposed to effectively showcase its real-world utility. By creating a controlled environment that simulates varying grid frequencies, we can directly connect our device to this setup, allowing it to respond to these changes by dynamically adjusting the water heater's activity, providing a demonstration of its capabilities in maintaining grid stability. Another advanced goal is to implement the water temperature into the decision-making process, allowing more on/off control mechanics near the temperature deadband. Finally, implementing touch-screen functionality with additional information screens will ensure a better user experience.

Stretch Goals: For our stretch goals, we are aiming to interface into the internal workings of the water heater. We plan to develop a mechanism to interface directly with the internal controls of the water heaters. Another stretch goal we have is the development of a smartphone application that will provide homeowners with comprehensive access to all the information displayed by the smart display. Through this app, homeowners will be able to monitor their water heater's operational status, access real-time grid frequency data, and gain information regarding their monthly costs. The final stretch goal is to implement a "vacation mode" so that the user can schedule on/off times for additional control.

2.3 Objectives

The aim of our project revolves around the objective of devising a practical and consumer-centric solution that will support grid stability during periods when it faces heightened stress levels. As the demand for electricity surges, the grid often struggles with the challenge of maintaining a steady frequency. Our solution

centers on the optimization of residential water heaters (and potentially any other appliance) by designing a system with the capability to quickly detect these frequency fluctuations and subsequently trigger the automatic shutdown of these appliances in response. Our primary goal is to reduce the costly necessity of grid stabilization measures, such as activating generators to compensate for the stressed grid.

Initially, our design was envisioned to work exclusively with Grid Interactive Water Heaters (GIWH), which are designed to respond to fluctuations in the grid. However, as a team, we realized that to make a substantial impact, it was necessary to broaden our scope. Therefore, we have adapted our design to be compatible with any electric water heater, not just those with already existing grid-interactive capabilities. This shift enables our device to contribute to grid stability more extensively by allowing a wider range of households to participate in demand-response programs, regardless of their current water heater technology.

In circumstances where the grid is stressed, the frequency may dip below the standard 60 Hz threshold. The objective of our design revolves around the automation of a product that promptly turns the water heater off or on when it detects frequencies dipping below or rising above a predetermined set point (such as 59.7 Hz or 60.3 Hz respectively). This design idea is geared towards helping grid stability by mitigating the need to activate generators (which can be very costly) to stabilize the grid. It is also important to note that as our power grid shifts more to renewable energy, demand side response will be the only way to counteract the stress the grid occurs. Typically, with nonrenewable energy sources, grid stress is fixed by ramping up production to meet the increased demand. This option isn't available with renewable energy sources, as their output depends on environmental conditions, which are beyond our control. To counter this, energy storage systems can bank excess energy when conditions allow for greater renewable output, and smart grid technology further aids by dynamically balancing energy supply and demand.

Our goal is to have this product widely available and used in many households. We hope to incentivize consumers by facilitating them in an enrollment in a program that yields rebates from the electricity provider.

2.4 Prior Related Work

2.4.1 SkyCentrics CTA-2045 module

The SkyCentrics CTA-2045 module is a product that allows for communication between household appliances and external systems, such as utility companies. This module is specifically designed to be inserted into various appliances through AC 'slots', which establishes a communication link with the internet. Once this link is established, it enables control through SkyCentrics applications and allows for participation in special utility rate plans which could prove beneficial during peak

demand times [1]. This communication capability allows homeowners to schedule their water heater for Time of Use programs and enable participation in utility demand response programs through SkyCentrics web and mobile applications, which could result in rebates for the customer.

One of the notable advantages of this module is its ease of installation. A homeowner could easily install the SkyCentrics CTA-2045 module with just a Phillips head screwdriver in under 5 minutes. This installation time encompasses hardware setup, SkyCentrics account creation, and device connection to the Wi-Fi network.

Even though the detailed technical specifications were not available, the SkyCentrics module adheres to a particular set of guidelines known as the ANSI/CTA-2045 standard. This standard was developed by the American National Standards Institute (ANSI) and the Consumer Technology Association (CTA) to facilitate communication between appliances like water heaters or air conditioners and external systems like the electrical grid. It supplies a common language for these appliances and systems to communicate, specifying certain communication methods and data transmission rates. Following this standard, the SkyCentrics module is engineered to enable reliable communication between appliances and external systems.



Figure 1: CTA-2045 device diagram

2.4.2 Gridfriendly™ Water Heater Controller

The Grid Friendly Water Heater Controller from Pacific Northwest National Laboratory (PNNL) is designed to provide smart grid services using existing electric water heaters [2]. It uses the thermal energy storage of water heaters to offer quick and automatic regulation (both increasing and decreasing) with short-duration time intervals for the power grid, aiding in grid stabilization during high-demand periods. This product utilizes the Grid Friendly™ Appliance chip, which is the brains of the operation.

This autonomous controller controls appliances like water heaters on demand-side grid services based on observations from the AC voltage signal. Specifically, the controller can manage under-voltage scenarios where water heaters recognize sudden voltage drops in the distribution line, triggered usually by nearby electrical faults (such as a falling tree on a power line). The controller then cuts down the electric load of the water heater to prevent adding stress to the grid. The predetermined voltage thresholds that initiate this response, along with planned delays, prevent a sudden reintroduction of a large electric load into the grid, which could potentially worsen grid stress.

The controller in Grid Friendly Appliances (GFAs) (which includes Grid Friendly™ Water Heater Controller) monitors the power signal at its plug and turns the device off when the frequency drops below a certain threshold (e.g., 59.95 Hz), and turns it back on when the frequency recovers to its nominal value (e.g., 60 Hz). As far as the technical aspects of the GFA's go, the GFA controller includes optimizing the form and placement of the controller on the appliance to shed its load in response to grid stress. This includes having a power relay (or a solid-state power electronic switch) to command the water heater accordingly. Additionally, the controller design was improved to ensure effectiveness in frequency protection by selecting curtailing frequency thresholds appropriately.



Figure 2: Grid Friendly Appliance chip retrofitted to Water Heater

2.4.3 Electrical Grid Frequency Meter

An electrical grid frequency meter was designed and developed by Rob Ruark. He notes that the “instantaneous frequency of the electrical grid is rarely exactly 60 Hz” and sought to create a device to monitor exactly that. In his report he mentions that the normal range of frequencies is between 59.95 and 60.05 Hz. The lower bound of the frequency is typically caused by overloading or consumption of the

grid while the higher bound is caused by under generation on the power generation side.



Figure 3: Analog frequency detector

He mentions the use of "Phase Measurement Units" which are units utilized by utilities companies to measure instantaneous frequency and the distinct phase of the grid. In low-voltage device voltage measurement, two common methods are used: transformer isolation and direct coupling. Transformer isolation involves reducing voltage using a transformer's turns ratio, while direct coupling employs an impedance divider. Direct coupling can lower voltage without wasting power, a technique often found in cost-effective capacitive dropper circuits suitable for low-power, non-isolated power supplies. Choosing direct coupling over a bulky and costly transformer was a preference he stated. Purchasing 120V to 12V AC 'wall wart' power supplies would have been expensive compared to board-mounted AC to DC supplies, and integrating a transformer would have required additional components like rectifiers, numerous electrolytic capacitors, and a buck converter for powering the rest of the circuit.

The AC Line Zero Crossing Detector Circuit incorporates a 1M resistor to limit inrush current during hot plug events and a 1nF capacitor to reduce voltage from 170V peak to around 4V peak. Since this circuit is AC-coupled, it is biased to mid-rail to ensure the waveform stays within the common mode range of the comparator. A resistor (R3) introduces hysteresis to prevent output oscillations in the presence of line noise. This hysteresis, along with reference voltage offsets, adds a mostly constant phase offset but does not affect frequency measurement [3].

This device successfully measures and displays nominal grid frequency. The rationale behind this project's parts selection and specific circuit design are helpful with our project and will be a valuable resource to reference.

2.5 Specifications

Requirement	Specification	Priority
Frequency Detection	6.00 Hz – 400.00Hz Range 1% Resolution ± 1% Accuracy	High
Voltage Measurement	5V – 140V Range 5% Resolution ± 5% Accuracy	Medium
Current Measurement	0A – 30A Range 5% Resolution ± 5% Accuracy	Medium
Load Detection	Detect Status of Water Heater Binary signal - 0(off) 1(on)	High
Water Heater Controlling Mechanism	≤ 1s Response Time ≤ 1s Refresh Rate	Med
Interactions Counter	≥ 95% Working Rate	Low
Display	≥ 480x270 pixels ≥ 3" Diagonal Length	Medium
MCU	≥ 16 MHz ≥ 50 GPIO pins ≥4 KB ≥2 I2C Channels ≥2 SPI Channels	Medium

Power Supply	5V DC ± 0.1%	High
Weight	≤ 5lbs	Low
Temperature Sensor	25°C - 90°C Range Operating Voltage: 3.3v-5v Accuracy ≥ ± 1°C	High

Table 1: Requirements and Specifications

2.6 House of Quality

We wanted to ensure that the tradeoff between technical requirements and consumer requirements was fair so that both the utility company who would be utilizing this project for aid in grid stabilization as well as the customer who would have this product installed in their household.

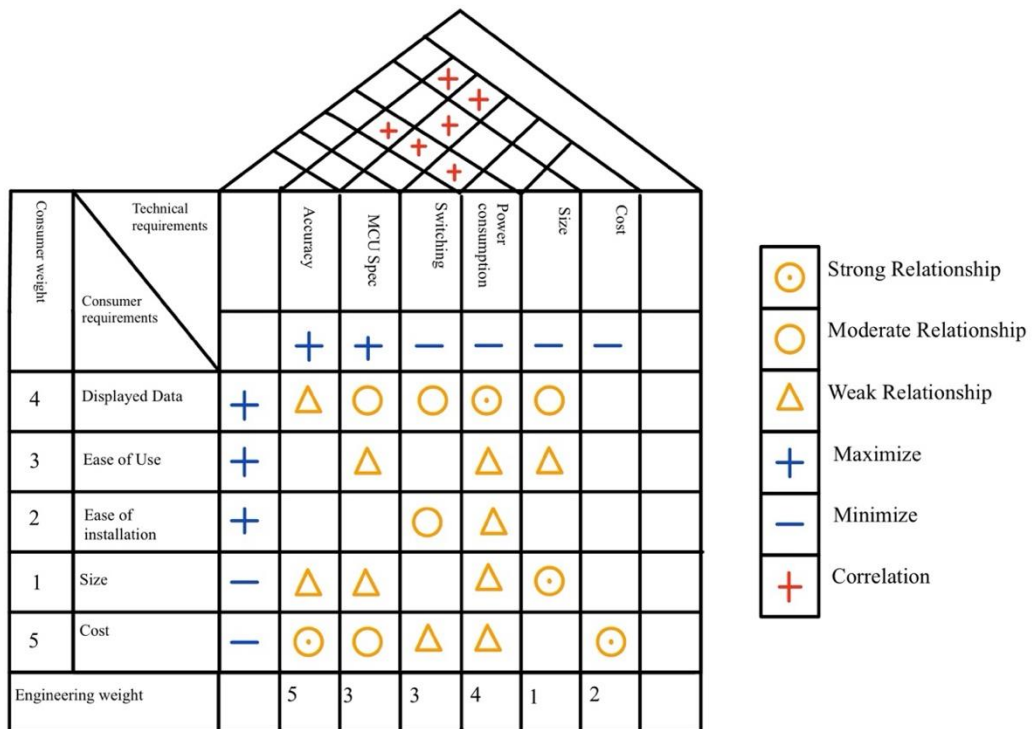

Figure 4: House of Quality

We felt that the most important aspects of the product on the consumer side was that the displayed data was useful, the product was easy to use, and easy to install. We felt that size and cost were less important given that this product would be installed near the water heater (where it would likely not be visible) and would presumably be paid for by the utility company with an included rebate for the customer.

We felt that the most important aspects of the product on the Engineering side was that the accuracy of the readings we take and the specifications of the MCU. We felt that in terms of time it takes for the device to switch off should be minimized, Power consumption should be minimized, the importance of size was also minimized since this product will be located near a water heater, and we felt that since we want a reliability and accuracy, the cost of the product was also minimized.

2.7 Hardware Block Diagram

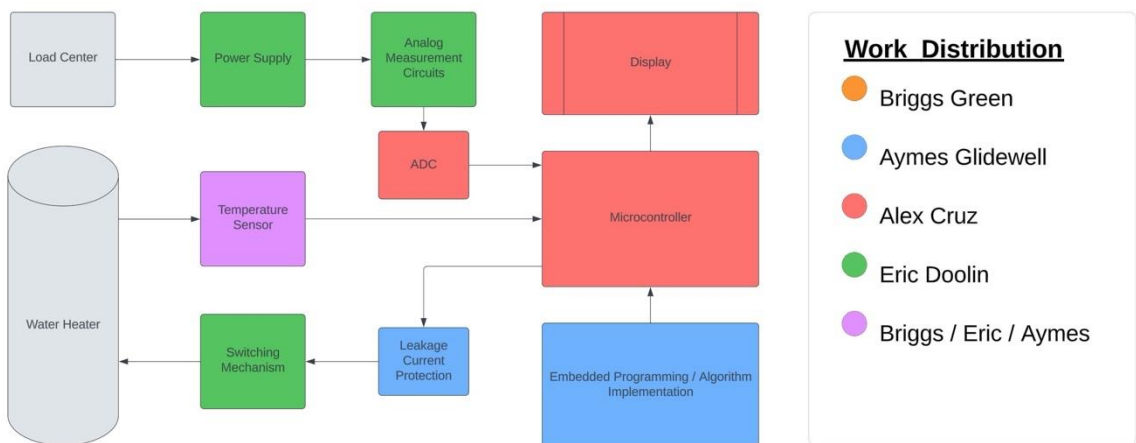

Figure 5: Hardware Block Diagram

3 Research

3.1 General Research on Electric Water Heaters

3.1.1 Electric Water Heater

This section of research on electric water heaters is critical to understanding how our device will interface with the water heater. The goal of this section is to analyze the inner workings of a water heater to gain a foundational understanding of its functionality. Once we understand this, we can design GSFD so that it integrates

seamlessly into existing water heaters such that a desired result can be accomplished while maintaining normal operation and safety of the water heater.

3.1.2 Functionality

Electric water heaters are designed to heat water using electricity, featuring heating elements that warm the water to a preset temperature controlled by a thermostat. These heaters come in different models. Tankless versions for on-demand hot water and storage-tank models with a hot water reserve. For designing GSFD, we will only be focused on storage-tank electrical water heaters. This can include models with a single or double thermostat configuration.

When hot water is used, such as someone taking a shower or running a hot load of laundry, it is immediately replaced by cold water in the exact amount. The new cold water then goes to the bottom of the tank via the "dip tube". The cold water at the bottom of the tank is first sensed by the lower thermostat which then communicates to the upper thermostat. If the upper thermostat determines that the top of the tank is still hot, but the bottom has an insufficient temperature, then the bottom heating element will engage.

In a storage-type water heater, there is something known as the "first-hour rating." This rating is usually around 30% higher than the tank's storage capacity. As soon as the heating elements (upper and lower thermostats) detect a decrease in water temperature, they kick in to start heating more water. This means that within one hour, you can get over 50 gallons of hot water from a water heater nominally rated for 40 gallons [4].

3.1.3 High Temperature Limiter Device

A major hurdle we must overcome is interacting with the water heater and integrating our device such that we can control its load on the power grid. The high-temperature limiter device installed on every water heater could be a solution. The main purpose of this device is to be an automatic kill switch for the coils so that the water temperature does not go above 150°F. Water temperatures above this threshold are considered dangerous and will burn the skin. If we can figure out a way to imitate the signal to this device that shuts off the power usually being sent by the master thermometer, we may be able to have GSFD send a signal for a very short amount of time needed to stabilize the grid by temporarily reducing the load of the water heater.

3.1.4 Thermostats

There is no thermostat inside the tank; instead, upper, and lower thermostats are placed on the outside within direct contact with the metal shell of the water heater tank. The internal heat of the water is transferred through the metal via conduction and the thermostats get a read-out. The two locations except where the T-stats

are located are completely covered in insulation. Below we will analyze the upper and lower thermostats and their functionality:

Upper Thermostat – The upper thermostat (Located highest on the water heater) is the main controller for most water heaters. This thermostat acts as a temperature activated switch, which turns on and turns off the heating process.

Lower Thermostat – The lower thermostat is controlled by the upper thermostat and acts as a secondary reference point for the real time internal temperature of the water heater.

3.1.5 Electric Water Heater Schematic

Wire (L1 – Black) - The hot wire (L1) is at 120vrms. It connects to terminal (1) of the high-temperature limit switch. In the diagram below this wire is labeled as black and connects to the junction box which ties it into to the main residential panel.

Wire (L2 - Red) - Line two or (L2) is the second hot wire in our diagram. It is exactly like the (L1) wire, but it connects to terminal (3) of the Hi-temperature limit switch. These two wires are what power the entire water heater and will be vital in integrating GSFD. Our plan is to not utilize L2 and instead use L1 as the primary line to power GSFD [5].

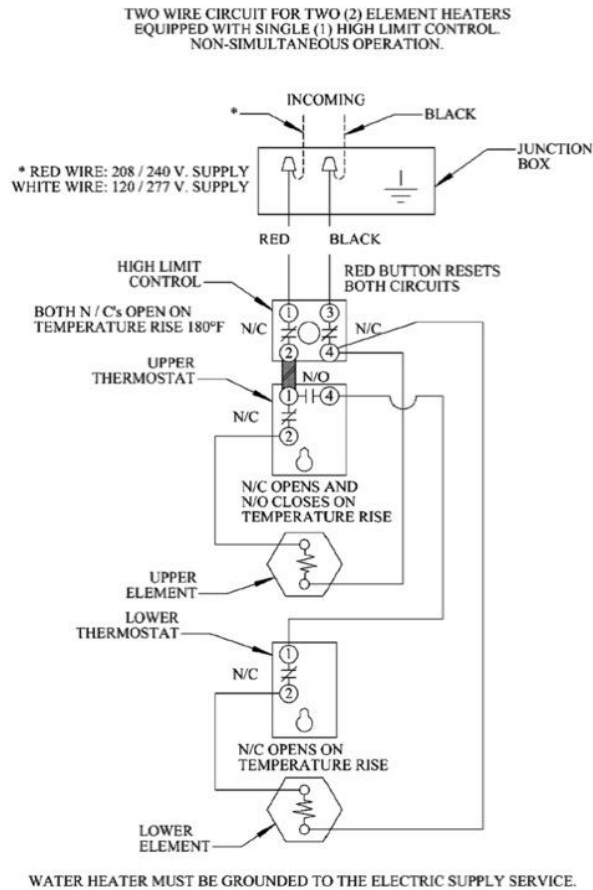

Figure 6: Water Heater Wiring

3.2 Technology Comparison, Parts Comparison and Selection

3.2.1 Switching Mechanism

The core of this project is to turn on and off a water heater based on certain deciding factors, in this case, grid frequency variations from a determined nominal frequency. Therefore, this project needed a fast, robust, and reliable switching mechanism to control the operation of the water heater when the frequency of the grid changed.

3.2.1.1 Thyristor

The first switching method we researched was the thyristor, which is a solid-state semiconductor device often referred to as silicon-controlled rectifier. There are two main types of thyristors that could potentially be used for this application: the three-layer and four-layer designs. In the three-layer design, a small current at the gate is used to control a larger current between the anode and cathode. In the four-layer design, the control of the larger current between anode and cathode is done by a potential difference between the other two terminals [7].

One of the biggest advantages of a thyristor is that there are no moving parts, therefore the longevity for this switching method is ideal while maintaining an adequate level of reliability. Another advantage is that thyristors can handle high voltage and current levels, which is important for this application, especially if controlling the entire 30-amp max rating of the electrical branch powering the water heater.

While thyristors have several advantages, they do inherit some disadvantages that may be relevant to this application. Firstly, they are small and often surface mounted devices. While this could be a good thing from a design perspective as would be easy to implement into the PCB design and not take up additional space within the case, the gauge of wire necessary to handle 30 amps is rather thick and could prove difficult to connect to such a small component on a PCB. Another large disadvantage to thyristors is that, unlike a physical switch that would open the circuit, the thyristor is “opened” by creating a large resistance between the two terminals. This could prove problematic in the functionality of our device due to no real isolation from one terminal to the next. One final disadvantage is that thyristors don’t like voltage or current spikes when they are in off mode, as they could lead to the thyristor turning on when unwanted.

3.2.1.2 Relay

The second method that we researched to control the water heater was to use a relay. These devices can be constructed in several ways, but for our application, we looked at the electromagnetic and solid-state relay designs. Electromagnetic relays have physical contact points that are activated by electromagnetism generated from a small current signal. This type of relay is often used in circuitry to control a larger current load with a smaller current control. Solid state relays on the other hand, do not have physical contact points, and thus no moving parts [8]. These work by applying a potential difference between two terminals which activate a coupler to bridge between two isolated ends, allowing current to flow. These couplers are often LEDs that emit photons which are then sensed on the other side by a photo-sensing receiver.

There are many advantages to utilizing relays for this specific purpose. For one, there are many different relay types that can be utilized, which come in a variety of sizes, shapes, and ratings. Both types of relays researched are simplistic in

design and offer straightforward, reliable functionality. While both types would seem suitable for this application, solid state relays offer a distinct advantage over electromagnetic relays in that there are no moving parts, increasing longevity and reliability, and they produce less electromagnetic interference. In general, relays are also generally faster in operation than thyristors.

One of the major downsides to utilizing a relay is the time it takes to activate. While still relatively fast, they do have a slight delay in switching operation. The electromagnetic relay also has moving parts that could wear out over time. One final disadvantage of electromagnetic relays is contact bounce and arcing, which could prove to be problematic in this application.

3.2.1.3 Switching Mechanism Comparison

Switching Mechanism	Advantages	Disadvantages
Thyristor	<ul style="list-style-type: none"> • No Moving Parts • Large Current Handling 	<ul style="list-style-type: none"> • Difficult to Connect Large-Gauge Wires • Large Current Conductors Too Close to PCB
Relay	<ul style="list-style-type: none"> • Reliable • Quick 	<ul style="list-style-type: none"> • Heavy • Bulky

Table 2: Comparison of Switching Mechanisms

3.2.2 Switching Relay

After researching the various switching methods that could be used to control the power flow to the water heater, we realized that there are many considerations that must be carefully evaluated. Firstly, since we were dealing with high voltage, large current power lines, it was imperative to prioritize safety. Whether this is installed by a professional or by the homeowner, the safety standards must be upheld for this design to be realizable. Therefore, it was important to choose a switching method that can safely handle 120Vrms AC signals with a maximum of 30A current flow without arcing or burning up. While it is possible for the voltage levels in the line connected to the switching mechanism to spike and go above (or below) 120Vrms, the current is limited by the 30A double-pole breaker in the load center. Also, since the value of 120 in the 120V line represents a relative value (in this case relative to ground), yet only the ‘hot’ line will be connected to the switching mechanism, the voltage is of less concern as the value of 120 wouldn’t be relative to anything related to the switching mechanism. Another crucial aspect that needed to be considered was the reliability of the switching mechanism. This device revolves around quick and reliable operation in controlling the on/off status

of the water heater for it to function correctly as a grid stabilizing frequency device. Therefore, careful consideration was taken to ensure the switching method could operate quickly, precisely, and have a low reset rate. The changes in frequency of the grid happen incredibly quickly, so having a switch that can control the water heater instantly is paramount for the success of this device [6].

Having looked at both the thyristor and relay options for the switching mechanism, we ultimately decided to move forward with a relay to act as the switching mechanism for this project. The reasons behind this were many, but the primary one was that having a larger diameter and higher gauge wire connect to our PCB onto the thyristor was something that we felt could be problematic, and we wanted to factor in several steps of safety and isolation where possible to prevent damage to components, which could lead to malfunctions of our device and therefore present danger to the user or customer.

After deciding to move forward with the relay to act as our switching mechanism, we started researching the different kinds that could accomplish the task at hand. Since we need to switch the power flow for an AC load, we ruled out all relays that were DC voltage specific, as well as all the relays with amperage ratings under 30A. The next criteria that we looked at was how this relay was going to interact with our device and the water heater. First, we looked at how a relay is implemented as a switch and the commonly found terminals present on most relays. In their simplest form, a relay takes an input signal to act as a control, which is often a potential difference between two terminals, and uses this signal to open and close the connection between a separate set of terminals. These other two terminals would be connected in series between the source and the load, for whichever conductor is necessary to interact with for manipulating the on/off functionality of the load.

Once we had these parameters narrowed down, we started looking into the various types of relays that could perform the desired task. Some of the common types that we found are electromagnetic relays, reed relays, latching relays, and solid-state relays. While all of these essentially serve the same function, they are constructed in different ways.

3.2.2.1 Electromagnetic

Electromagnetic relays are commonly used in electrical systems and have been around for a long time. Because of the way they are constructed, they are also commonly referred to as electromechanical relays. These function by activating the relay's coil by introducing a current, which in turn generates a magnetic field. This magnetic field creates an attractive or repellant force on an arm, often a ferromagnetic material such as iron, which physically opens or closes the circuit on the high side of the relay. This allows for mechanical isolation between the two terminals when the relay is in an "open circuit" state.

3.2.2.2 Reed

This type of relay is a modification of the electromagnet relay. While still being a physically actuated switching relay, the method behind the actuator is slightly different. In the reed relay design, the singular ferromagnetic arm is replaced by two flexible magnetic blades encapsulated within an inert-gas-filled tubes. When the coil of the relay is energized, the two blades are attracted or repelled from one another, opening or closing the circuit. This design mitigates a small amount of wear and tear of the mechanical components found in purely electromagnetic relays, prolonging the lifespan of the device.

3.2.2.3 Latching

Another type of electromagnetic relay switch is the latching relay. These function the same way but add another element to the overall design that could be useful in certain situations. Unlike the general electromagnetic or reed relays, latching relays can maintain an energized secondary side even after the primary side is de-energized. This could be advantageous if we wanted to keep the switch open for a period of time without having to continuously energize the control terminals, which could possibly make our device more energy efficient.

3.2.2.4 Solid State

The final type of relay that we investigated was the solid-state relay. These differ from the previous types in that they don't contain any moving parts. Most solid-state relays consist of an optocoupler, which isolates the control-side circuitry from the high-voltage/high-current load side to prevent damage feeding back to the controller, along with some triggering circuitry and a powered switch, often a MOSFET transistor or TRIAC. There are many benefits to this design over mechanically switched relays for high-current switching applications. For one, the lack of moving parts removes the issue of wear and tear, especially since the contacts can be worn out faster when switching occurs during mid cycle. The benefit of the opto-isolation is also a benefit to protect the controller, which in our application would be the microcontroller on the PCB.

3.2.2.5 Normally Open vs Normally Closed

The final consideration we investigated was how the relay is configured. As with many different switching types, the contacts on the load side of the relay can be configured to be normally open or normally closed. While both configurations could be used in this device, we wanted to ensure that we kept efficiency and power consumption in mind throughout the decision-making process. Because of this, we went back the general water heater wiring diagram to see which configuration would best suit our application. With a normally open relay, the controller would have to provide a constant voltage across the control terminals in order to keep the 120V line running between the load center and the water heater energized. With this configuration, when the device interacts with the water heater, the

microcontroller would shut off the control signal opening the switch. With a normally closed relay, the controller would not be sending a control signal to the control contacts during normal operation of the water heater and would therefore only send a control signal to the relay when the device interacts with the water heater. After looking at both of these options, we found it best for both power consumption and efficiency to opt for the normally closed style solid state relay.

3.2.2.6 OMRON

The first solid state relay we found was the OMRON G3NA-240B-UTU DC5-24. This relay is rated for a maximum 40A and has an output range of 24V to 240V AC. The switching method is zero crossing, so the output terminals will open and close when the control input waveform goes to zero. The benefit to this type of delayed switching is that switching at zero reduces the signal noise that can be created when switching AC loads during a peak or valley in the waveform. The downside is that in a worst-case-scenario, the opening and closing of the switch could be delayed by one half cycle. At 60 Hz, this would be roughly 0.0083 seconds, or 8.3 ms. This should be adequate for our design. Another consideration for this is that the control supply for this one is from 5 to 24V DC, so the microcontroller would need to be able to supply 5V at minimum, else we would need to step up the voltage before going to the control terminals.

3.2.2.7 CRYDOM

The Crydom D2450T-B is another solid-state relay that is similar in size to the above OMRON one, but this one has wider control band of 3 to 32V DC. This could prove ideal since many microcontrollers, such as the MSP430s have dedicated 3.3V output GPIO pins, so the implementation could be easier. The input current range is from 3.4 mA to 30A, which is a wide range. This relay is also rated to handle 24 to 280V AC and up to 50A on the output side, more than enough for our application. Another thing that this relay has that the OMRON does not is the choice to switch at zero crossing or instantaneous. This would provide flexibility in our design. The response time is the same at 1/2 cycle, and this one is rated to operate from -4 to 80 degrees Celsius.

3.2.2.8 SSR Comparison and Selection

	OMRON G3NA-240B-UTU DC5-24	Crydom D2450T-B
Control Voltage	5 to 24V DC	3 to 32V DC
Input Current	≤ 40A	3.4mA to 30A
Output Voltage	24 to 240V AC	24 to 280V AC
Max Output Current	40A	50A

Switching Mode	Zero Crossing	Zero Crossing or Instantaneous
Switching Component Type	Phototriac	SCR
Operating Time		½ Cycle
Operating Temperature	-22 to 176 F	-40 to 80C
Dimensions	1.1 in x 2.28 in x 1.69 in	1.75 in x 2.25 in x 0.89 in
Standards	CE Certified CSA Certified TUV Certified UL	CSA Approved TUV Approved UL Approved CE Compliant
Price	\$86.14	\$75.08
Source	Mouser.com	Mouser.com

Table 3: Solid State Relay comparison

3.2.3 Voltage Measurement Methods

One primary element to this device is the ability to monitor the frequency present quickly and accurately in the water heater power lines, which is directly related to the incoming AC voltage signal coming in from the utilities. Therefore, it is essential to develop a robust and accurate voltage detection system that can be utilized in this system both for the dual 120V AC lines as well as the stepped-down AC voltage levels elsewhere in the system, primarily the frequency detection circuitry. We looked at several voltage detection methods to determine the best balance between safety, accuracy, components, and design as it fits into the overall system. These methods will be used in conjunction with an analog-to-digital converter to send a digitized data bank to the microcontroller.

3.2.3.1 Voltage Divider

$$V_{out} = V_{in} * \left[\frac{R2}{R2 + R1} \right]$$

As one of the most widely used methods of detecting voltage levels, a voltage divider circuit was the first consideration. Since the voltage divider would read the divided voltages coming in from each 120V line, the displayed voltage on the LCD would need to be scaled back up by the ratio of divider circuit. But utilizing a voltage divider would provide additional benefits that could be useful in other parts of the design. Since voltage dividers can also act as signal conditioners to clean up variations in a signal, the divided voltage could be used to power additional parts of the circuit such as a microcontroller or active components such as operational amplifiers. Similarly, a voltage divider can be used as a reference voltage for a specific element within the circuit and could therefore also be used to bias transistors and operational amplifiers in various parts of the circuit [8].

One of the biggest advantages of utilizing a voltage divider is the simplicity at which they can be implemented. By using inexpensive passive components, they can be realized with very few parts and for very little cost. Another benefit to the voltage divider is the versatility that it could provide, giving not only voltage readings to display on the LCD, but to also generate a reference voltage with much lower magnitude to be utilized elsewhere in the circuit at a much safer voltage level.

One of the biggest drawbacks to using a voltage divider is the limited power handling abilities. Voltage dividers rely on resistor circuits which dissipate a lot of heat, and therefore higher power handling could create higher temperatures within the circuit. Another drawback to voltage dividers is the accuracy constraints on the output voltage reading. Each physical component within the circuit, such as resistors, have an accuracy tolerance, which increases as the number of components increases.

A consideration for utilizing a voltage divider is whether the divided voltage will be used elsewhere in the circuit or not. The output voltage reading will be different based on whether the output voltage node is connected to a load or not.

3.2.3.2 Rectifier

Another option to approximate an AC voltage value is by using a rectifier circuit to convert the AC signal to DC. By arranging diodes in a specific pattern, which only allow current to flow one way within that branch, we can effectively create a positive-only waveform. There are generally two basic approaches to rectifier circuits:

3.2.3.2.1 Half-Wave Diode Rectifier

First, we looked at the half-wave, which runs the signal through a single diode. The diode only allows the electricity to flow in one direction, so only one half of the input signal is used, resulting in a pulsing signal at the output. This can be either the positive half or negative half of the input signal, but the magnitude of the value will be the same [9]. Once the pulse signal is generated from the diode it can be cleaned up using a capacitor across the load. This will create a ripple in the output

waveform as the capacitor is discharged. This output signal can then be tuned by adjusting the capacitance value to smooth the output DC voltage waveform.

$$r = \frac{I_{ac}}{I_{dc}} = \frac{V_{ac}}{V_{dc}}$$

Where

$$r = \frac{1}{2\sqrt{3}fCR}$$

If appropriately tuned, the magnitude of the ripple voltage will be null, and the output voltage waveform will be constant.

The advantages to utilizing a half-wave diode rectifier is that it is the simplest approach and uses the least number of components. The output signal may only represent half of the input signal, but it still provides an amplitude value and relevant information for determining a voltage level.

The disadvantage of the half-wave diode rectifier is that an accurate voltage measurement is more difficult as the output is only half of the input.

3.2.3.2.2 Full-Wave Bridge Rectifier

A full-wave bridge rectifier works in much the same way, but unlike the half-wave diode rectifier, the full-wave rectifier utilizes both positive and negative parts of the input sinusoidal waveform. This doubles the frequency over the half-wave as well as doubles the times the capacitor is charged and discharged. This would decrease the magnitude of the ripple voltage over that of the half-wave rectifier. The full-wave rectifier circuit can utilize the entire sinusoidal waveform by using four diodes arranged in the form of a Wheatstone bridge. This can be done by introducing a capacitor to act as a filter, in the same way as the half-wave, filtering out the ripple voltage to generate a true DC voltage value equivalent to the average, or RMS value of the original AC input signal.

An advantage to using a full-wave bridge rectifier is that the DC signal at the output could be used elsewhere in the circuit to supply DC power to active components such as operational amplifiers or transistors. Another advantage is that the circuit could be made with minimal components, specifically four diodes and a single capacitor in its simplest form, all of which are also inexpensive and readily available. Bridge rectifiers also have good voltage regulation, which is ideal for obtaining accurate measurements [10].

A consideration of the full-wave bridge rectifier circuit as an AC voltage meter is that high-amperage diodes will be necessary to handle the current draw and mains voltage levels going to the water heater. The 1N4007 diode is rated for 1000V and up to 30A, which is sufficient for this application.

3.2.3.2.3 Center Tap Full-Wave Rectifier

Another option is to use a center tap full-wave rectifier which uses two diodes connected to a center tap transformer, which outputs both halves of the input signal as positive waveforms. This happens when the positive half of the input signal is present, current flows through one diode down to the center of the transformer winding, and then when the input signal is negative, current flows through the opposite diode to the center of the transformer winding, essentially mirroring the negative half wave up to a positive half wave.

One advantage of the center tap rectifier is that it offers lower peak inverse voltage over the bridge rectifier. Another advantage is that it is slightly more efficient when compared to the bridge rectifier as only two diodes are conducting, resulting in reduced diode loss.

The primary disadvantage of the center tap rectifier is that transformers are more expensive than diodes, and often bulky and heavy, increasing the size and weight of the circuit, and are also more expensive [11].

3.2.3.2.4 Rectifier Type Comparison

Rectifier Options	Advantages	Disadvantages
Half-Wave Rectifier	<ul style="list-style-type: none"> • Simple to build • Inexpensive 	<ul style="list-style-type: none"> • Not Ideal for Accurate Voltage Measurement
Full-Wave Rectifier	<ul style="list-style-type: none"> • Simple to Build • Inexpensive • Better Output Over Half-Wave 	<ul style="list-style-type: none"> • Needs Conditioning • Needs Specific Diodes for Large Currents
Center Tap Rectifier	<ul style="list-style-type: none"> • Better Output for Measuring Voltage • Less Diode Loss over Bridge 	<ul style="list-style-type: none"> • Bulky • Expensive

Table 4: Rectifier Comparison

3.2.3.3 Capacitive Voltage Sensor

Another method of detecting a voltage and gaining a numerical value for the voltage is by using a capacitive voltage sensing circuit. This method would take the high voltage signal going to the water heater, and using a capacitor-driven potential divider, generate an output voltage signal proportional to the sensed

magnitude of the input signal. However, this method would also need additional components similar to the options mentioned above to compensate for any inaccuracies in the output voltage levels. Therefore, the output signal would likely need to be conditioned, by possible amplification or further filtering, to smooth the signal out. Once the output voltage signal has been filtered and cleaned, it would be possible to maintain it as an analog signal to use elsewhere in the circuit or convert it to a digital signal using an analog-to-digital converter. For the digitized signal, this data could be fed into the microcontroller and manipulated mathematically to display closely the original AC input voltage signal.

Utilizing a capacitive voltage sensing circuit has several advantages. For one, the non-contact method allows for galvanic isolation, which would aid in isolating the output voltage signal from noise and interference that could increase inaccuracies in the reading. Another large advantage is that capacitive sensors can sometimes minimize the risk of electric shock and arcs. Capacitive sensors can also handle a wide range of voltage levels for the input signal, which is important for this application being able to handle the higher voltage levels going into the water heater. These circuits also minimize loading effect errors while also having a reduced sensitivity to electro-magnetic fields that may be present elsewhere within our design, which could aid in the accuracy and stability of our measurements in the presents of electrically noisy environments. A final advantage for this option is the low power consumption needs that these circuits generally have, making it suitable for our application.

While there are several beneficial advantages for capacitive sensing circuits, they do have some drawbacks. One of the biggest is that they can often be sensitive to environmental conditions such as humidity, temperature, and atmospheric pressure, which could have a profound effect on the accuracy of the output signal. Another potential drawback is that capacitive sensing circuits can often introduce phase shifts into the output signal due to the nature of capacitors. Also, due to the capacitive nature of these sensors, this circuit, if not isolated properly, could potentially suffer from electrostatic coupling with nearby capacitors elsewhere in the system, increasing the need for complexity in the sensor design. Size is also a consideration as implementing compensation devices such as temperature compensation, phase adjustments where necessary, and linearity compensation could push the design to be too large and complex for this purpose.

3.2.3.4 Voltage Comparator

Another option to measure the voltage would be to implement a voltage comparator. While comparators don't solely measure a numerical value for the output voltage, they can be used in tandem with an analog-to-digital converter to generate a numerical value. One design is the Successive Approximation ADC that applies different voltage levels one input of the comparator and adjusts the applied voltage to match the input voltage from the water heater, outputting the corresponding voltage measurement. Another is a Flash ADC, which uses multiple comparators in parallel with unique voltage levels and compares the unknown

input voltage, outputting a binary representation of the numerical value. Another option is the Single-Slope and Dual-Slope ADCs, which compare the input voltage from the water heater to a ramp voltage to determine the unknown voltage [12]. ADC's will be discussed in more detail later in the paper.

The advantage to utilizing a comparator along with an analog-to-digital converter is that the output voltage would be digitized already and able to be fed into the microcontroller for display on the LCD.

A disadvantage to using a comparator is that depending on the design, the reference voltage could take too much time to ramp up until the comparator found a match, in the case of the Slope ADC, or that the comparator would need to be supplied with various levels of AC voltage to be compared to, in the case of the Successive Approximation and Flash ADCs.

3.2.3.5 Voltage Measurement Methods Comparison

Voltage Measurement Method	Advantages	Disadvantages
Voltage Divider	<ul style="list-style-type: none"> • Simple Design • Inexpensive components • Versatility 	<ul style="list-style-type: none"> • Heat Dissipation • Accuracy based on resistor tolerances
Bridge Rectifier	<ul style="list-style-type: none"> • DC voltage output • Voltage regulation • Inexpensive components 	<ul style="list-style-type: none"> • Must use high amp-rated diodes • Costly if using center tap transformer rectifier
Capacitive Sensor	<ul style="list-style-type: none"> • Galvanic isolation • Minimizes loading effect errors • Reduced sensitivity to EMF • Low power consumption 	<ul style="list-style-type: none"> • Sensitive to humidity, temperature, and pressure • May induce phase shift at output • Could be too large if implementing drawback compensation
Voltage Comparator	<ul style="list-style-type: none"> • Good Over-Voltage Protection 	<ul style="list-style-type: none"> • Slow • More Difficult to Design

Table 5: Voltage Measurement Comparison

3.2.4 Current Measurement Methods

The purpose of measuring current flowing to the water heater is two-fold. One, the current can be used as a data point to display on the LCD to enrich the level of information provided to the consumer. The second is that the current will be used to calculate the power consumption of the water heater, which can be displayed on the LCD. This power consumption calculation can also be used to calculate the monetary amount that the customer is paying for this device if a dollar-per-kilowatt-hour amount is entered in by the user.

3.2.4.1 Shunt Resistor

As a common method of measuring current within a circuit or wire, shunt resistor circuits were the first method that we researched. This is a very straight forward approach to measuring the current and can be accomplished simplistically and inexpensively. Implementing a resistor with a very low known resistance value, a small voltage drop is created across the shunt resistor, and the voltage value is then used to find the current through that branch. This current will be a smaller representation of the reference current and will be calculated based on the known resistor value [13].

One of the biggest advantages to utilizing a shunt resistor to measure the current is that shunts can handle extremely high amperage ratings while generating a minimal voltage drop. Another advantage is that shunts are readily available in a myriad of sizes, shapes, and resistance values.

One of the biggest disadvantages of utilizing a shunt resistor rated around 30 amps, or the maximum current going to most water heaters, can be rather large or bulky. Another disadvantage is that shunt resistors do not provide galvanic isolation, and in the case of measuring larger currents, are increasingly less power-efficient [13].

3.2.4.2 Current Divider

$$I_{out} = I_{in} * \left[\frac{R_t}{R_x + R_t} \right]$$

Another method for measuring the current flowing to the water heater that we researched was the current divider. This is a similar concept as a shunt resistor circuit but allows for multiple parallel paths that can further reduce the measured current in the branch. But, in its simplest form, a current divider can be constructed with two resistor branches where the current through the metered branch can be calculated with Kirchhoff's current law and Ohms law.

The benefits of utilizing a current divider circuit are that the metered current branch can be used to drive current to another part of the device, similar to the voltage divider. Depending on the number of resistors setup in parallel and their respective values, the current in the metered branch could be very low compared to the original current from the water heater.

One of the biggest drawbacks to utilizing a current divider for measuring current is that it would reduce the current to the water heater. This would occur as some of the current would be diverted into the current divider circuit to be further divided and stepped down. Another drawback comes from the need to handle the full current load going to the water heater, which is generally on a 30-amp breaker. This level of current is extremely dangerous and increases the safety risk of this device.

3.2.4.3 Hall-Effect Sensor

Another common method for measuring current is a Hall-effect sensor. These sensors work by detecting the magnetic field generated by the flow of electrons, which is directly proportional to the current. These sensors can be executed in both an open-loop and closed-loop configuration. In the open-loop configuration, the current flows through the wire that is situated inbetween a magnetic core, generating a magnetic field, which creates an output voltage that can be utilized elsewhere in the system. However, the open-loop method has some drawbacks in that there is an increased risk of linear errors and gain errors, which could affect the accuracy.

of the current measurement. In this setup, the magnetic core is also at an increased risk of saturation. In the closed-loop configuration, a feedback loop is used to generate a secondary winding, which adjusts the current in the secondary winding, cause another magnetic field that can cancel the magnetic field of the primary winding, resulting in a net zero magnetic field [14].

An advantage to using a Hall-effect sensor is that there is some flexibility in how it is applied. Depending on the other circuits and how all pieces fit together, this could be advantageous in our design. Another advantage is that these sensors have higher safety elements given the galvanic isolation. Finally, unlike the shunt resistor, Hall-effect sensors avoid power dissipation and could be useful in that regard.

One of the disadvantages of using this method to measure the current going to the water heater is that with a higher level of current, there will be higher magnetic fields that could have an unwanted effect on other parts of the circuit.

3.2.4.4 Current Step-Down Transformer

The final method for measuring current is using a current transformer. These consist of a primary coil, which is simply a wire conductor through which the current to be measured flows, and a secondary coil, which is a wire conductor wound

around a magnetic core. The current flowing in the primary conductor creates a magnetic field which induces a current in the secondary coil. The ratio of primary to secondary windings determines the step-down (or step-up) factor of the current. Since the ratio is known for a specific transformer, the current on the primary side can be calculated based on the measurement of current taken on the secondary side [15]. This primary/secondary relationship also makes current transformers scalable by adjusting the turn ratio, allowing this method to be applicable to a wide variety of applications.

There are several advantages to using a current transformer as a method of calculating or measuring current in a wire. The first is that current transformers provide excellent galvanic isolation between the high-power circuit and the measuring instrument on the secondary winding, enhancing safety and preventing any direct electrical connection. Another advantage is that the measurement taken from current transformers are known to be highly accurate for many applications, especially high-current systems such as water heaters. The primary advantage that a current transformer offers as it applies to our application is that they can be easily integrated into existing systems without major modification, as they are simply placed around the conductor which carries the current to be measured.

There are, however, some disadvantages to using a current transformer to measure the current in a wire. The first is that these devices can often be bulky and expensive when compared to other current-measuring methods. Another is that these can often have a limited frequency response making them less appropriate for some applications. Another disadvantage is that under high-current conditions, the core of the transformer can become saturated, leading to inaccuracies in the measurement. And the final disadvantage is that current transformers can induce phase shifts, which could affect power calculations if used in that capacity.

3.2.4.5 Current Measurement Methods Comparison

Current Measurement Methods	Advantages	Disadvantages
Shunt Resistor	<ul style="list-style-type: none"> • Can Handle Large Currents • Lots of Options in Size, Shape, etc. 	<ul style="list-style-type: none"> • Large Current Capacity Means Large Physical Size • No Galvanic Isolation
Current Divider	<ul style="list-style-type: none"> • Offers Reduced Current Levels to be Measured 	<ul style="list-style-type: none"> • Would Reduce Current of Measured Conductor

Hall-Effect Sensor	<ul style="list-style-type: none"> • Offers Galvanic Isolation • No Power Dissipation • Can Measure AC and DC • Ease of Integration 	<ul style="list-style-type: none"> • Creates Large Magnetic Fields from Large Currents • Accuracy Dependent on Temperature
Current Transformer	<ul style="list-style-type: none"> • Offers Galvanic Isolation • Ease of Integration 	<ul style="list-style-type: none"> • Induces Phase Shifts • Only Applicable Before Rectification

Table 6: Current Measurement Comparison

3.2.5 Current Transformer

After comparing different ways to measure current in our design, we decided that current transformers would likely be the best option due to many reasons. Firstly, their inherent ability to provide electrical isolation between the measurement circuit and the high-power system is beneficial to our design. This feature ensures the safety of both the users and the sensitive electronic components in our design as it prevents high voltage from the power system from reaching the low-voltage electronics.

Additionally, current transformers are highly accurate and capable of handling the large current ranges associated with grid applications without direct contact with the high-current paths. This is especially important in our application, where precise current measurements are essential for detecting the grid frequency changes that indicate a stressed or underloaded grid condition.

Another significant advantage is the ease of integration into existing systems. Unlike other sensors that might require significant alterations to the monitored circuit, current transformers can be installed without any interruption to normal operation. This characteristic is particularly valuable during the initial setup and for any maintenance that may be required.

The scalability of current transformers allows them to be used in a wide range of settings, from small-scale laboratory prototypes that we will be doing during the breadboard testing phase, to full-scale industrial installations. Given the scope and objectives of our project, current transformers present a reliable and practical solution that meets our technical requirements while also offering the flexibility to adapt to different operational scales. There are two main types of current transformers that we will discuss for the scope of our project.

3.2.5.1 Solid-Core

A solid core current transformer is one of the types of current transformer used for measuring alternating current (AC). It consists of a primary winding through which the current to be measured flows, and a secondary winding on a single, continuous core, usually made of a high-permeability material like silicon steel. This core provides a magnetic pathway that is unbroken, which ensures that the magnetic field generated by the current in the primary winding is efficiently transferred to the secondary winding.

The solid core design is preferred in situations requiring high accuracy, as it typically offers better performance in terms of lower core losses and minimal phase angle error, which is needed for precise measurements. The solid core's construction means that the transformer must be installed by threading the conductor through the core itself, a process which is typically done during the initial setup of the electrical system [16].

One trade-off with solid core transformers is that they are not as convenient to install in existing systems when compared to split core transformers, which can be clamped around conductors. However, their accuracy and stability make them ideal for permanent installations where the conductor does not need to be disconnected for the transformer to be installed or removed.

The Amgis CT1030 and Talema Group AC1030 are two solid core current transformers that we researched for our design, each with specifications that cater to particular requirements in current sensing applications.

The Amgis CT1030 is designed for a current range of 0-30A, making it suitable for small to medium-sized electrical systems [17]. Given our input AC Voltage will likely never exceed 30 Amps given that most residential water heaters are connected to a 30 amp circuit breaker, this value should be good enough for our design. The output voltage of 3V for a 30A load will provide our ADC with a voltage comfortably within its input range. With an accuracy of 0.2%, the Amgis CT1030 offers precise current measurements, which is important for applications requiring exact electrical monitoring and control. The turns ratio of 1:1000 is relatively standard, providing a useful range of measurement for the expected current flow. The frequency range of 50Hz to 1kHz suggests that this transformer can handle the standard grid frequency as well as higher frequencies, which may be advantageous for certain types of electronic equipment that operate beyond the typical 60Hz frequency found in North American grids [18].

The Talema Group AC1030 also covers a current range of 30A but offers a broader smaller output voltage of 1V, which would also fall within the acceptable range of our ADC input. An accuracy of 0.35% is slightly less than the Amgis CT1030, but still within acceptable for many industrial and engineering applications. Like the Amgis, it also has a turns ratio of 1:1000, ensuring a reliable transformation of current for measurement purposes. The specified frequency range of 50/60Hz is

focused exclusively on the standard power grid frequencies, which suggests that this transformer is highly specialized for typical power grid applications.

When choosing between these two options for our GSFD project, we would need to consider the specific requirements of our system. If we prioritize higher accuracy and a wider frequency range, the Amgis CT1030 will be the preferable choice. However, if we require a lower output voltage range and can afford a slight reduction in accuracy, the Talema Group AC1030 may be more suitable. It's also worth considering the compatibility of the output voltage with our existing measurement and control equipment, as well as how the accuracy specifications align with our project's tolerance for error.

3.2.5.2 Split-Core

A split core transformer is the other common type of current transformer that is designed to measure alternating current (AC) in a conductor without the need to disconnect the conductor or shut down the system. Unlike solid core transformers, which have a single, uninterrupted magnetic core, split core transformers feature a core that can be opened or "split" apart. This allows the transformer to be clamped around a conductor, making installation and removal quick and straightforward, an essential feature for retrofit applications or when it is impractical to disrupt the current flow.

The split core design is particularly beneficial when monitoring is required in an existing setup, as it avoids the need for any interruption to the electrical service. These transformers are also versatile and can be used in a variety of situations where temporary measurements are needed, or where the installation of a solid core transformer would be too cumbersome or costly.

Split core transformers generally come with a slight trade-off in terms of accuracy and performance compared to solid core transformers due to the potential for a small air gap in the magnetic circuit when the core is closed. But with advanced manufacturing techniques, their precision has been greatly improved, making them a reliable option for many applications, as well as our design.

The YHDC SCT013 0-100A transformer can measure currents from 0 to 30A, which is ideal for a broad range of residential and commercial applications. It provides a high output voltage of 4.38V [19], which is substantial and could be beneficial in systems where a higher output signal is required for better resolution or for compatibility with certain monitoring equipment. The accuracy is stated as $\pm 1\%$, which, while not as precise as some solid core options, is typically sufficient for general current monitoring purposes. A turns ratio of 1:1800 indicates a strong ability to step down high currents to a manageable level, and its specified frequency range of 50/60Hz makes it suitable for standard power grid applications. The "Clamp on/Split Core" feature makes it easy to install, allowing it to be added to existing circuits without any interruption.

The Nidec C-C10 covers a wider current range from 0 to 100A, suggesting its use in higher capacity systems that may experience larger current flows [20], which may not be applicable to our design since it is unlikely that the product will ever see currents as high as 100A. Its lower output voltage of 0.2V implies that it may be more suitable for systems that require a lower voltage signal. The accuracy of 0.35% is better than that of the YHDC model, offering more precise current measurement which could be critical for applications that demand higher measurement fidelity. The turns ratio of 1:3000 is quite high, implying that the output current it provides can also be quite high, which is an important aspect for us to keep in mind for sensitive measurement devices. The frequency range of 50/60Hz matches that of the YHDC model, and both are split core, clamp on style transformers that are easy to install.

3.2.5.3 Current Transformer Comparison and Selection

Current Measurement Components	YHDC 30A SCT013 0-100A	Amgis CT1030	Talema Group AC1030	Nidec C-CT10
Rated input	0-30A	0-30A	0-30A	0-100A
Rated Output	4.38V	3V	1V	0.2V
Accuracy	±1%	±0.2%	±0.35%	±0.35%
Turns Ratio	1:1800	1:1000	1:1000	1:3000
Operating Frequency	50/60Hz	50Hz-1kHz	50/60Hz	50/60Hz
Installation Type	Clamp on/Split Core	Through Hole/Solid Core	Through Hole/ Solid Core	Clamp on/Split Core
Price	\$9.50	\$8.87	\$6.81	\$9.99
Source	DigiKey	DigiKey	DigiKey	Mouser

Table 7: Current Transformer Comparison

3.2.6 Frequency Measurement Methods

A primary requirement for this device is to quickly and accurately measure the frequency of the sinusoidal signal coming in from the grid and into the water heater. The minute variations in the frequency of the grid will be the determining factor of how this device controls the water heater. A common method to measuring frequency is to first convert the sinusoidal waveform to a square waveform to get a more accurate measurement of the period. While this isn't the only method to measuring frequency, we feel that it is a possible strategy to get an accurate frequency reading.

3.2.6.1 Analog Comparator

The first method we researched for converting the 60 Hz sinusoidal waveform going to the water heater was the analog comparator. This can be designed using a single operational amplifier utilizing a method known as "zero crossing". This works by outputting a high signal when the voltage is in the positive region of the waveform, and a low signal when the voltage is in the negative region of the waveform. This pulsation generates a high/low periodic square wave.

The benefits to utilizing an analog comparator is that they can be applied for a wide range of frequencies. Since the grid operates at roughly 60 Hz, it's imperative to adopt a conversion method that can accurately function at that frequency.

One of the major drawbacks of a general analog comparator is that accuracy is reduced if there is any noise in the signal. This can disrupt the output square waveform if the noise causes the signal to jump above or below the zero threshold.

3.2.6.2 Schmitt Trigger

The second method of converting the sinusoidal waveform to a square waveform we researched is the Schmitt Trigger. This is a specific type of comparator that utilizes a feedback loop, generally with a resistor in series. The feedback loop addresses the noise problems of the general analog comparator, reducing inaccuracies in the output waveform.

An advantage of the Schmitt Trigger besides the fact that it handles noise in the input signal better than a general comparator, is that the hysteresis characteristics ensure clean and sharp transitions between high and low states, increasing accuracy of the frequency reading. Another advantage is that they can work with a variety of input signals while creating a stable and reliable output.

The main disadvantages of using this is that the performance can be dependent on the stability of its power supply as it is often an active component, and that the possibility of hysteresis loop can become present in certain applications where temperature changes and environmental factors are varying [21].

3.2.6.3 Peak Detection Circuit

Another method used to determine frequency is by implementing a peak detection circuit. These can be designed in many ways utilizing a wide variety of components, making them versatile for many specific applications. One circuit option is to implement an op-amp with two resistors, a diode, and a capacitor. The input sinusoidal signal first runs through a resistor to limit current flowing to the op-amp, which is biased at a DC voltage level (based on what range we would want the output signal set at). The output of the op-amp is then fed to a diode to block current from flowing backwards, while a feedback resistor connects the secondary side of the diode back to the inverting input of the op-amp. The output is then a small sinusoidal voltage, where the peak lags the input waveform peak by 90 degrees. This output signal can then be fed directly into an ADC as the entire waveform is shifted up around the bias point, negating any negative values which the ADC can't compute [22].

An advantage to designing a peak detection circuit would be that they could be specifically tailored to our application, and then they can be constructed using minimal, inexpensive parts and components.

A disadvantage to designing a peak detection circuit would be that the output waveform would still possibly need to be conditioned or filtered to appropriate levels by implementing additional components before the signal is fed to the ADC.

3.2.6.4 Zero-Crossing

Zero crossing detection is a common technique in frequency measurement of a periodic waveform. This method tracks the number of times the signal intersects the zero-voltage level within a predefined interval. By counting the crossings, one can infer the frequency of the signal.

When implementing zero crossing detection for frequency measurement, a standard practice is to monitor the signal over multiple cycles of a known reference frequency. This extended observation period allows for a larger data set, thereby increasing the accuracy of the measurement. It effectively mitigates the influence of phase noise, which can introduce variability in the timing of the zero crossings. Phase noise, a form of signal interruptions, can cause the signal to deviate slightly at the points where it crosses the zero threshold. By considering multiple periods, these deviations have a reduced impact on the overall measurement, as they represent a smaller fraction of the total observation window. Zero Crossing detectors are also commonly used as square wave generators [23].

It's also important to note that zero crossing detection is not instantaneous—it requires a certain amount of time to establish an accurate reading. This is due to the need to observe the signal over a duration that spans multiple cycles. The method prioritizes accuracy over speed, resulting in a more reliable measurement but at the slower update rate. This trade-off is often acceptable in applications where precision is more critical than rapid measurement response.

The advantages of the zero-crossing detector lie in its precision and ability to reduce noise, which are essential for our project. This accuracy is key for synchronizing with the grid's fluctuations, ensuring efficient and stable operation. The detector's noise reduction feature enhances the reliability of our measurements, an important aspect in maintaining consistent performance. Additionally, its capacity to enable energy-efficient switching at the most effective points in the AC cycle aligns with our aim to optimize power usage and extend the longevity of our system. Safety is also a significant benefit, as the detector helps prevent hazardous conditions and protects against equipment damage in our high-voltage environment. Its cost-effectiveness and adaptability to various AC voltage levels make the zero-crossing detector a practical and efficient choice for our application.

3.2.6.4.1 Optocoupler

One approach to designing a Zero crossing detector for our project is to incorporate an Optocoupler Zero Crossing detector. This type of circuit typically includes a full-wave diode bridge to rectify a AC signal, which enables the detection of zero crossing events during both the positive and negative phases of the waveform. A current-limiting resistor is used to condition the rectified signal, protecting the optocoupler from excessive current. Inside the optocoupler, there is an infrared LED that when illuminated, activates a phototransistor. The zero crossing of the AC signal is indicated when the AC voltage is sufficient to turn on the LED, which in turn causes the phototransistor to switch and generate a corresponding output signal. This signal, typically pulled to the required level through a resistor, can be monitored by a microcontroller. The use of an optocoupler provides electrical isolation, which can help to protect the low-voltage digital side from the high-voltage AC side, ensuring safe and accurate phase synchronization for control applications.

3.2.6.4.2 Comparator Circuit

In a zero-crossing detector circuit, the output state is toggled whenever the incoming AC signal passes through the zero-voltage level. This process is orchestrated by comparing the incoming signal, which has been appropriately scaled down, with a reference level set at zero volts. The scaling down ensures that the signal remains within the operational limits of the circuit. A protective element is also integrated to prevent the input from dropping too low, which could otherwise disrupt the circuit's functionality.

There are many advantages of integrating this circuit into our design. It's a simple solution with high precision for accurately monitoring the grid's frequency. Its simplicity allows for easy implementation into our system, and its fast response time is critical for the rapid adjustments required for grid stabilization [24].

There are also a couple challenges that we need to consider. The sensitivity of the circuit to electrical noise can result in false triggers or missed zero crossings, which

could lead to erroneous frequency readings—a potential setback for the accuracy we aim to achieve. The circuit's reliance on the AC signal's stability means that any irregularities could adversely affect its performance. It also lacks built-in high voltage isolation, an important feature for ensuring safety and protecting the electronics in our design, however, if we implement external circuit protection at a previous point in our design this disadvantage is not important.

3.2.6.4.3 NPN Zero Crossing

The circuit begins by directly rectifying an alternating current (AC) signal using a full-wave bridge rectifier. This rectifier converts the AC signal into a unidirectional current, fully rectifying it without losing any part of the waveform. Once rectified, the signal's voltage levels are monitored. The NPN transistor in the circuit plays a critical role here: when the rectified signal's voltage drops below 0.7 volts, the threshold voltage for this transistor, the transistor switches to a high state. In this high state, it outputs 5 volts, and this condition persists until the waveform's voltage crosses the 0.7-volt threshold again [25].

Given that the waveform is fully rectified, it will make this threshold crossing three times for one complete cycle of the original AC waveform. Each of these crossings results in the NPN transistor outputting a high signal, leading to three high signals for each full cycle of the AC waveform. These signals from the NPN transistor are then sent to an Analog-to-Digital Converter (ADC), which feeds the data to the MSP430. The MSP then calculates the time taken for these three high signals to occur, effectively measuring the duration of one complete cycle of the rectified AC waveform, giving us an accurate frequency reading.

3.2.6.5 Frequency Measurement Methods Comparison and Selection

Frequency Measurement Methods	Advantages	Disadvantages
Analog Comparator	<ul style="list-style-type: none"> • Works With a Wide Range of Frequency 	<ul style="list-style-type: none"> • Less Accurate When Noise is Present
Schmitt Trigger	<ul style="list-style-type: none"> • Accurate Due to Hysteresis • Stable Output 	<ul style="list-style-type: none"> • Dependent on Power Supply Stability • Less Accurate with Wide Temperature Fluctuations
Zero Crossing Detection	<ul style="list-style-type: none"> • High Accuracy 	<ul style="list-style-type: none"> • Signal Noise May Impact Accuracy

	<ul style="list-style-type: none"> • Fast Response Time 	<ul style="list-style-type: none"> • Lacks High Voltage Isolation
Peak Detection Circuit	<ul style="list-style-type: none"> • Customizable for Wide Range of Applications 	<ul style="list-style-type: none"> • May Need Additional Filtering

Table 8: Frequency Measurement Methods

3.2.7 Temperature Measurement Methods

3.2.7.1 Thermocouple

A thermocouple temperature sensor is made by joining two different metals at one end often referred to as conductors. When this joint is heated or cooled, it generates a voltage that correlates to a temperature. What makes this type of temperature sensor unique is in the fact that the rating and temperature range is customizable depending on the specific types of conductors used for the probes. For example, if you use copper, the temperature range is -270 to 400°C [26].

For the GSFD project, thinking about using a thermocouple to measure temperature has its pros and cons. On the pro side, thermocouples are great because they can handle a wide range of temperatures, react quickly, last a long time, and are relatively cost effective. On the other hand, there are cons that make it not suitable for GSFD. They aren't always super accurate, especially for cooler temperatures. Over time, they will need to be checked and recalibrated to ensure accuracy. Also, setting them up looks challenging due to the way they work. Another thing to account for is that they can get thrown off by electromagnetic stuff around them due to the way the sensor generates voltage. Finally, the signal they give off is weak, so it needs to be boosted. Having to boost the output signal will add additional complexity to our project.

3.2.7.2 Infrared (IR)

An Infrared (IR) sensor is a non-contact temperature measurement device that detects infrared radiation emitted by an object to determine its temperature. This type of sensor is useful for measuring surface temperatures from a distance, making it ideal for applications where direct contact with the object is not wanted. [27]

Due to the nature of this sensor being non-contact, it causes additional challenges when integrating it with the GSFD project. The main issue with this is that the entire water heater is coated with insulating material. This insulating material would make it extremely challenging to get an accurate internal water temperature. For the reasons listed above, using an IR sensor is not feasible.

3.2.7.3 Resistive

Resistive temperature sensors are constructed with two different metals. As the temperature changes, a resistance is created between these two metals relative to the change in temperature. By utilizing a reference resistance and a base resistor value dependent on the type of metals used, the output of the sensor will be mostly linear. This discrepancies in linearity can be compensated by using sensors with more wires (2-wire, 3-wire, 4-wire). The 2-wire sensor is prone to added conductor resistance based on wire length, while the 3-wire has partial compensation, and the 4-wire has a two-method compensation that is most accurate.

3.2.7.4 Semiconductor-Based

Semiconductor based temperature sensors work by utilizing the principle of semiconductor devices in that the internal materials change in correlation to the temperature. Inside of the sensor is a diode, when a constant current is applied, changes in temperature can be measured as the voltage within the sensor goes up or down. This is how the sensor accurately measures temperature.

They are known for their accuracy and ease of interfacing with integrated circuits and mcu's as they output a digital signal. Compared to the other sensors listed above, a semiconductor-based temperature sensor may be the best option for GSFD due to this reason alone, but further research is needed. The typical

ranges of semiconductor-based temperature sensors are between -55 and 150 degrees Celsius, the water heater should be well within that range.

3.2.7.5 Temperature Sensor Comparison

After comparing a wide variety of temperature sensors, below is a compiled table of the strengths and weaknesses relevant to GSFD. The primary factors that we are considering when comparing these are accuracy, output signal type, accuracy, temperature range, and ease of integration. For the output signal, it is a priority to pick a sensor that has a digital output for ease of integration into GSFD. The temperature range needs to be within the possible range of temperatures that the water can be at from room temperature to 175 degrees Fahrenheit.

	RTD	Thermo-couple	Infrared	Semi-Con. Based
--	------------	----------------------	-----------------	------------------------

Operating Principle	Bi-metal resistive difference	Seebeck effect (voltage generation due to temperature difference at junction of two different metals)	Detection of infrared radiation emitted by an object	Variation in voltage across a semiconductor junction with temperature
Surface Mounted	no	Yes	No	Yes
Output Signal	Analog voltage	Analog voltage	Analog or digital	Analog or digital
Accuracy	Moderate (varies with number of wires)	Moderate (varies with type and range)	Lower than contact sensors	High within designed range
Temp Range	-90 to 270 C	Wide range (-200°C to 1750°C, depending on type)	-70°C to 3000°C (varies by model)	-55°C to 150°C (typical)
Ease of Integration	Easy	Moderate (requires amplification and conversion for digital systems)	Easy for models with digital output	High (especially for digital systems)
Susceptibility to Interference	Low	Moderate (can be affected by electromagnetic interference)	High (affected by atmospheric conditions and transparent surfaces)	Low (but susceptible to self-heating)

Table 9: Temperature Sensor Comparison

By analyzing the table above, a semiconductor-based temperature sensor is a great option for its ease of integration, temperature range and accuracy, output signal being digital, low susceptibility to inference and ability to be surface mounted. While choosing a final temperature sensor, a thermocouple model could be applicable depending on cost and other factors.

3.2.8 Temperature Sensor Selection

When researching different types of surface mounted temperature sensors for our project, there were a few key specifications that needed to be met. Firstly, the output of the sensor needs to be digital. This requires a built in ADC to convert the analog signal to digital. This will allow for easy integration into GSFD by allowing the MSP430 to interface with the temperature sensor. The second important requirement is the operating voltage needs to be between 3.3-5v so we can power it from the MSP. Additionally, it is preferable to have a singular control wire for communication. Below is a comparison of 3 similar temperature sensors:

Model	DS18B20	RTD PT100	TMP75AID	AM2301B
Brand	Maxim Integrated	Evolution Sensors	Texas Instruments	Adafruit
Output Type	Digital	Analog	Digital (Serial-I2C, SMBus)	Digital (I ² C)
Accuracy	±0.5°C from -10°C to +85°C	±0.5°C	±1°C	±0.3°C at 20-90°C
Mounting Type	Surface Mount	Contact	Surface Mount	Surface Mount (Enclosed Shell Module)
Operating Temperature Range	-55 to +125°C	-90 to +270°C	-55 to +127°C	-40°C – 90°C
Operating Voltage	3.0v-5.5v	3.3v-5.5v	2.7v-5.5v	2.5v-5.5v

Interface Type	1-Wire	2-Wire	Serial-I2C, SMBus	I ² C
Resolution	9 to 12 bits (programmable)	Not specified	12-bit	12-bit

Table 10: Temperature Sensor Selection

The four sensors above DS18B20 [29], RTD Pt100, Texas Instruments TMP75AID [31] and the AM2301B [32] are similar in many specifications and satisfy the requirements listed above the table. However, the clear choice for GSFD is the RTD Pt100.

3.2.9 Circuit Protection

Circuit protection for our design is highly important as high voltages and currents could easily fry the internal circuitry of our design. The incorporation of an over-voltage protection circuit is an essential measure to ensure our systems stability against potential voltage surges or spikes. This circuit is designed to react promptly during over-voltage conditions, either by possibly diverting the excess voltage away or disconnecting the power supply, thereby avoiding potential damage to the internal circuitry.

3.2.9.1 Varistor

Varistors are specialized electronic components used for surge protection, their defining characteristic being a voltage-dependent resistance. The term "varistor" stemming from "variable resistor" where the resistance alters with the applied voltage. As the voltage escalates, the resistance of the varistor diminishes, and in instances of excessive voltage surges, the resistance drops significantly to either divert or clamp the unwarranted voltage, which helps protect the components contained in the circuit.

A varistor has a non-linear volt-ampere characteristic, meaning that its behavior changes with the voltage applied to it. Below a certain voltage threshold, the current passing through the varistor is negligible, similar to a resistor with a very high resistance. Conversely, when the voltage surpasses this threshold, the varistor's resistance decreases significantly, allowing more current to flow. Unlike conventional ohmic resistors, which adhere to Ohm's Law, varistors are categorized as non-ohmic resistors. Their resistance doesn't alter linearly with the applied voltage, making them effective in handling transient voltage scenarios and shielding the circuitry from potential damage [33].

Varistors predominantly come in two varieties:

Metal Oxide Varistors (MOV). This variant comprises a matrix infused with a ceramic mass of zinc oxide, alongside metals such as bismuth, cobalt, and manganese. The unique composition of metal oxide varistors renders them a reliable choice for managing voltage surges, encapsulating a blend of metal oxide within a ceramic matrix to monitor and control electrical current.

Silicon carbide varistor: At one time these were the most common type of varistor on the market before the MOV was introduced. A downside is their considerable standby current draw, requiring a series gap, which is a break in the circuit used to manage or interrupt current flow, it requires this in order to reduce standby power consumption, which is essential in high power, high voltage applications to minimize unnecessary power usage.

An advantage to incorporating a varistor in the GSFD design would be to its cost-effectiveness and ability to handle substantial surge currents. However, a notable downside is their degradation over time with repeated transient activity, which is a downside in most available circuit protection options we will be speaking of for this project. In a project like the GSFD where the reliability over time is something our design requires, this degradation could lead to a decline in performance and possibly failure in the circuit protection.

3.2.9.2 Fuse

Fuses serve as a one of the most common safeguards against overcurrent conditions, acting as a circuit interrupter when excessive current flows, preserving the internal circuitry it is connected to. Specifically, a fuse operates by "opening" or breaking the circuit to halt the current flow when an overcurrent event occurs, preventing potential damage to the circuit components. Various types of fuses are designed to address different scenarios. For instance, fuses provide overload protection in circumstances where the current exceeds the circuit's normal full load-capacity without a short-circuit present, particularly during a momentary overload condition (known as "in-rush" currents) often seen during circuit initialization due to capacitor charging or motor-startup.

In managing short-circuit conditions where a low-resistance path leads to extremely high currents, fuses can be extremely valuable. By being placed in series with the circuit, they halt the excessive current resulting from a short-circuit condition, averting potential damage to the circuit and its components. Although primarily renowned for overcurrent protection, fuses can also offer a level of overvoltage protection, especially when working with other protective devices. Overvoltage conditions, which can trigger unstable system operation and pose danger to system users or operators, can lead to excessive current flow, which a fuse would be able to prevent or mitigate the damage to circuitry and users. Time-delay or slow-blow fuses can be employed for overload protection while also managing overvoltage that could escalate to excessive heat generation and increased fire potential.

Fuses are often housed in protective enclosures or fuse holders, which provide an additional layer of safety by minimizing the risk of short circuits, accidental contact, and potential fire hazards, as well as making them easily replaceable. The selection of the appropriate fuse is dependent on various parameters like the normal operating current and voltage of the circuit, whether the circuit is AC or DC, the operating ambient temperature, and the specific type of protection needed. The correct amperage of the fuse is gauged based on the full-load steady-state current of the circuit, and the fuse rating should be selected as to be 135% of this value, ensuring the fuse can handle transient overcurrent conditions without blowing prematurely [35].

Integrating fuses could present a compact, cost-effective, and reliable solution for overcurrent and overvoltage protection. Since fuses are readily available at many hardware stores, implication to our design would allow users to be able to replace them relatively easily. A downside to incorporating this into our design would be that when it exhausts its circuit protection capabilities, it must be replaced [36].

3.2.9.3 TVS Diodes

Transient Voltage Suppression (TVS) diodes, also known as transient voltage suppressors or avalanche diodes, are another option to implement in our design that would provide protection against voltage spikes and transient electrical occurrences which could cause damage the internal circuitry of the GSFD. TVS diodes are engineered to redirect over-voltages and have the capacity to dissipate high amounts of transient power. Their mode of operation entails shunting excess current away from sensitive components when the induced voltage surpasses the avalanche breakdown potential.

TVS diodes are just one of the many Transient Voltage Suppressors, which also include Metal Oxide Varistors (as previously discussed), Zener Diodes, and Bypass Capacitors. Transient Voltage Suppressors are generally classified into two operational categories: clamping and crowbar devices. Clamping devices, such as TVS diodes, limit the voltage to a designated level, acting to mitigate the effects of voltage transients in a timely manner.

Constructed with a p-n semiconductor junction, a TVS diode becomes conductive during a transient voltage spike, which is often associated with electrostatic discharge (ESD) events. This characteristic differentiates it from other diodes like Zener or Schottky diodes, making it a commonly used component for transient protection in circuit designs.

The main advantage of TVS diodes is their rapid response time. They can clamp the voltage at the output to the rated level within an short duration, responding in as low as picoseconds' time. This rapid response is vital in ensuring the protection of circuits from transient voltages which could otherwise cause significant damage. While other protection devices like Gas Discharge Tubes (GDTs) may take a few microseconds to respond and can handle larger surges, TVS diodes offer a more

immediate response to transient events, making them a preferred choice for many circuit protection applications [36].

In relation to the GSFD design, using TVS diodes could provide the needed protection against transient voltage events that stem from overvoltage conditions. By swiftly clamping down excessive voltages and shunting the surging current, this solution would provide a safe and relatively simple way to protect our circuit from overvoltage/overcurrent scenarios.

A downside to using TVS diodes in order to protect the internal circuitry of the GSFD would be its limited lifetime. TVS diodes can be damaged or degraded by repeated transient events, however it should be noted that we do not plan for frequent stress events to occur in our circuitry, so this downside is not a huge worry for our design. TVS diodes can also be more expensive than other options of circuit protection such as MOVs. In terms of single production costs (one unit) of the GSFD, this would be minute, however if scaled up to large production, the costs would be more noticeable.

3.2.9.4 Gas Discharge Tubes

Gas Discharge Tubes (GDTs) are the last option we will discuss to handle the GSFD's circuit protection. These components are notable for their ability to manage large surge currents typical of lightning strikes. Their operation hinges on a gas discharge mechanism, which activates when a surge overvoltage hits a specified threshold, transitioning the GDT from a high-impedance off-state to a low-impedance on-state. This transition enables the redirection of surge over currents to ground, protecting the downstream circuit components from potential damage.

While GDTs are successful in handling substantial surge currents, they present a slower response speed in comparison to other transient voltage suppression devices. Their relatively higher breakdown voltage also puts them more as second-level protection elements used for voltage limiting protection. The cost aspect of GDTs may be on the higher side initially, but their ability to endure multiple surge events without immediate replacement adds a layer of cost-effectiveness over time. The physical form of GDTs, although varied, might be bulkier compared to other protection devices, which could pose a challenge in space-constrained applications, which is likely why we will not utilize them in the final design of the GSFD, given that our design does have a limit on its physical size that we cannot surpass [37].

3.2.9.5 MOSFET

In Senior Design 2, we opted to use a MOSFET for circuit protection. After testing the control mechanism of the relay using the MSP430 launchpad, we experienced some current leakage from our solid-state relay that fried the MCU on board of the launchpad we were using for testing at the time. To prevent these occurrences, we incorporated a MOSFET which provided us with a faster and more reliable

switching mechanism. Given that the MOSFET is a voltage-controlled device, it allowed for precise control over its on and off states, ensuring that only the intended current could flow through the circuit. This solution was the most straightforward approach we could think of to protect the microcontroller from voltage and current surges.

3.2.9.6 Circuit Protection Comparison and Selection

Circuit protection Method	Advantages	Disadvantages
Varistor	<ul style="list-style-type: none"> • Cost-effective • Capable of handling substantial surge currents • Reacts quickly to voltage transients 	<ul style="list-style-type: none"> • Degradation with repeated transient events • Limited energy absorption capacity • May require replacement
Fuse	<ul style="list-style-type: none"> • Simple and effective • Inexpensive • Predictable performance • Variety of ratings available 	<ul style="list-style-type: none"> • Single-use • May not respond quickly enough to very fast transients
TVS	<ul style="list-style-type: none"> • Fast response time (picoseconds) • Capable of handling high transient power • Compact size 	<ul style="list-style-type: none"> • Can be more expensive than varistors and fuses • Limited energy absorption compared to some other devices
GDT	<ul style="list-style-type: none"> • Ability to manage large surge currents • High impedance in off-state aids in preventing unwanted current flow • Operational longevity across multiple surge events 	<ul style="list-style-type: none"> • Slower response speed • Relatively higher breakdown voltage • Bulkier physical size compared to other protection devices • Higher initial cost
MOSFET	<ul style="list-style-type: none"> • Precise control over switching • Low on-resistance and high efficiency 	<ul style="list-style-type: none"> • Can be damaged if too much voltage is applied

	<ul style="list-style-type: none"> • Rapid response to over voltage/current conditions 	<ul style="list-style-type: none"> • Needs careful setup to work correctly • Can get very hot if not managed well
--	---	---

Table 11: Circuit Protection Comparison

3.2.10 Communication Channels

3.2.10.1 SPI

SPI (Serial Peripheral Interface) is a synchronous serial communication protocol designed for high-speed data transmission between a master and a peripheral device. SPI employs multiple lines for communication, including a clock signal (SCLK), a data output/input (MOSI or MISO) and a chip select line (CS or SS) that is used when using multiple peripheral devices. It excels at high-speed data transfer and is commonly used for interfacing with sensors, displays, and other peripherals that demand rapid data exchange. SPI is well-suited for applications that require efficient and high-bandwidth communication. However, it can be more complex and difficult to connect one master to more than one device because it would require one chip select line for every peripheral device [38].

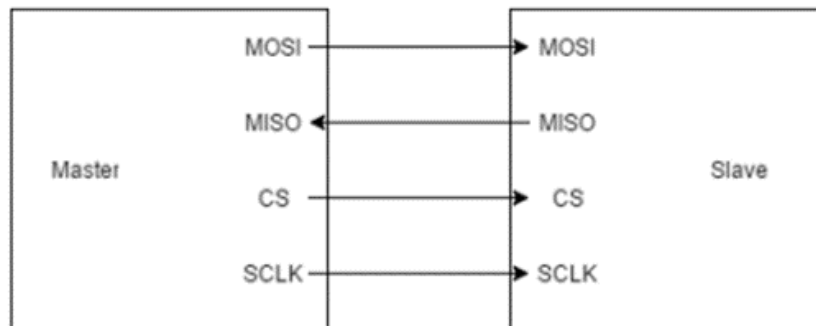

Figure 7: SPI Communication Interface

3.2.10.2 I²C

I²C (Inter-Integrated Circuit) is a widely used synchronous serial communication protocol designed for connecting multiple integrated circuits in a system. I²C uses a master-slave architecture as well and allows multiple devices to communicate over a shared bus. It is characterized by its simplicity, using just two wires for communication, Serial Data (SDA) and Serial Clock (SCL). Virtually any number of slaves and any number of masters can be connected on these two signal lines

and communicate with each other. I2C can be seen as a more efficient SPI because to connect more than one peripheral in SPI, another chip select (CS) line would need to be added which would take up another GPIO pin from the microcontroller. By using only two signal lines, I2C becomes simpler when wanted to have multiple peripherals. However, it may not be as suitable for high-speed as SPI [39].

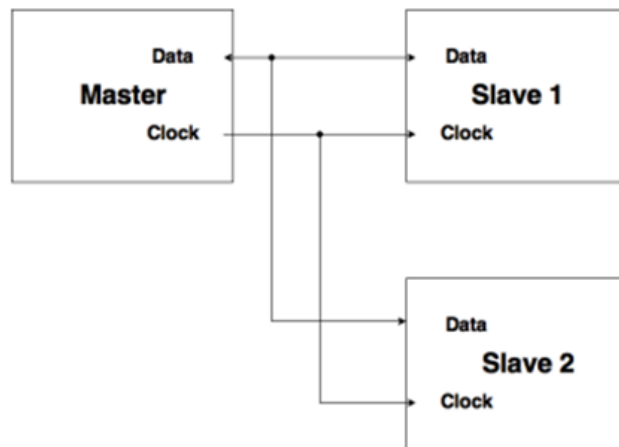

Figure 8: I2C Communication Interface

3.2.10.3 UART

UART (Universal Asynchronous Receiver/Transmitter) is an asynchronous serial communication protocol that is often used for point-to-point communication between two devices. It features separate transmit (TX) and receive (RX) lines, and data is sent one byte at a time, making it straightforward for transmitting textual data or binary information between devices. UART is highly versatile and widely supported in various microcontrollers and computer systems. Its main advantage is its simplicity and ease of implementation. However, it may not be the most efficient option for high-speed or multi-device communication, as it typically requires two separate wires for each device to communicate [40].

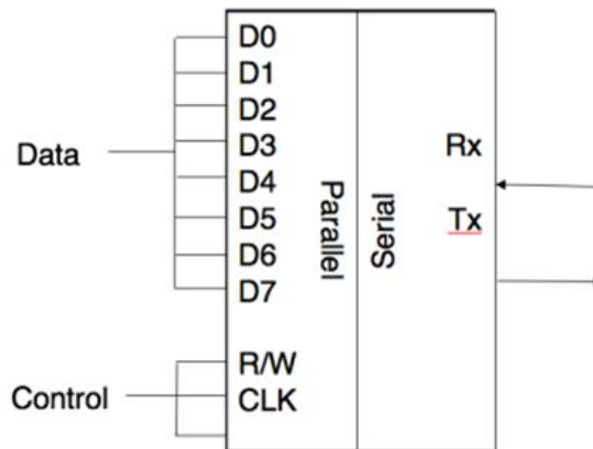

Figure 9: UART Communication Interface

3.2.11 Analog to Digital Converter

Microcontrollers are only able to read, process, and manipulate digital values. However, inputs like voltage would be coming in as analog signals. With that in mind, we would need a way to convert an analog signal into a digital value for the microcontroller to work with. This can be accomplished by using an analog-to-digital converter (ADC). The ADC we are looking for will need to prioritize speed as well as resolution. Speed will be very important because our microcontroller will have to act quickly and turn the water heater on/off as soon as it detects a frequency change above or below a certain point. Resolution is also important as we will be depending on accurate readings of analog signals that will give us the most accurate frequency reading [41].

3.2.11.1 SAR

SAR ADCs have a great balance between speed and resolution. These ADCs come in a wide range of resolutions, from 8 bits to 16 bits or even higher, making them suitable for applications that require precise measurements. The SAR algorithm involves a sequential approximation process where each bit of the digital output is determined through a series of comparisons, which inherently takes more time as the resolution increases. Additionally, SAR ADCs are relatively efficient in terms of power consumption, especially when not actively converting. The conversion speed, while not as fast as Flash ADCs, is generally reasonable for real-time applications.

SAR ADCs operate by iteratively approximating the analog input voltage by comparing it to a set of binary-weighted reference voltages. The conversion starts

with the most significant bit (MSB) and proceeds to the least significant bit (LSB). The ADC first guesses the MSB, setting it to 1, and checks if the voltage corresponding to this bit is greater or less than the input voltage. Depending on the result, the next bit is set to 1 or 0. This process continues until all bits are determined, resulting in a digital output closely matching the input voltage [42].

3.2.11.2 Sigma-Delta

Sigma-Delta ADCs are known for their exceptional resolution and outstanding noise performance, making them ideal for applications requiring precise measurements with minimal noise interference. However, Sigma-Delta ADCs have their share of disadvantages. Their conversion rates tend to be slower compared to other ADC types, which can limit their suitability in applications where speed is a top priority. The complexity of designing Sigma-Delta ADCs, often requiring additional digital signal processing to obtain meaningful results, can lead to longer development cycles and increased costs.

Sigma-Delta ADCs use oversampling and noise shaping to achieve high resolution. They oversample the input signal at a much higher rate than the final output requires and convert it into a high-frequency, low-resolution bitstream using a modulator. Through digital filters and decimators, the ADC effectively filters and averages noise, yielding a higher-resolution output [42].

3.2.11.3 Flash

Flash ADCs are usually the fastest, which is crucial in applications requiring rapid data acquisition. The simplicity of their architecture doesn't rely on complex algorithms or extensive digital signal processing, potentially leading to cost-effective and swift development. However, they generally provide lower resolutions, typically in the 8-bit to 10-bit range, limiting their suitability for high-precision applications. Flash ADCs are also power-hungry and may struggle with signals of wide dynamic range.

Flash ADCs work by simultaneously comparing the analog input voltage to a set of reference voltage levels using a bank of comparators. Each comparator determines whether the input voltage is greater or less than its associated reference voltage. The results from all comparators are encoded into a binary digital output. The speed of this approach arises from the parallelism of comparing the input voltage to all reference levels at once, eliminating the need for iterative approximation [42].

3.2.11.4 ADC Comparison

Selecting the most appropriate ADC type for our application requires consideration of speed and resolution. SAR ADCs strike a balance between resolution and speed, making them versatile and power-efficient. Sigma-Delta ADCs shine in precision and low-noise applications but trade off speed. Flash ADCs offer

unmatched speed but often at the expense of resolution and power efficiency. Therefore, we will be using SAR [42].

ADC Types	Advantages	Disadvantages
SAR	<ul style="list-style-type: none"> • Mid-to-high resolution with fast sample rate 	<ul style="list-style-type: none"> • Calibration needed for anti-aliasing
Sigma-Delta	<ul style="list-style-type: none"> • Highest resolution and low noise 	<ul style="list-style-type: none"> • Slower conversion
Flash	<ul style="list-style-type: none"> • Fastest option 	<ul style="list-style-type: none"> • Low resolution

Table 12: ADC Type Comparison

3.2.12 Sigma Delta ADC

When evaluating the Analog-to-Digital Converters (ADCs) for our Grid Stabilizing Frequency Detector (GSFD), we closely examined various models from Texas Instruments, focusing on key specifications such as resolution, sample rate, and the number of input channels.

3.2.12.1 ADC Comparison and Selection

When evaluating the Analog-to-Digital Converters (ADCs) for our design we closely examined various models from Texas Instruments, focusing on key specifications such as resolution, sample rate, and the number of input channels. Our criteria led us to consider four different sigma-delta ADCs that could potentially meet our project's requirements.

First, the on-board ADC that is built into our chosen microcontroller, MSP430F5529, is a 12-bit SAR ADC capable of 244kSPS (kilo sampler per second) with 14 channels. The speed helps capture plenty of samples over time for our device, although it does have a lower resolution than any of our other considerations. It is also good to note that this ADC is a part of the microcontroller so it will come with no extra cost and save space.

The ADS1158 is a 16-bit ADC capable of sampling at 125kSPS (kilo samples per second) across 16 channels [45], which offers extensive data acquisition capabilities. The fast channel scan and automatic sequencer features enable rapid switching between channels, making it suitable for applications where multiple signals need to be monitored simultaneously. Despite its lower resolution compared to 24-bit models, it provides a high sample rate, which could be critical for capturing transient events quickly and effectively.

On the other hand, the ADS131A04 is a 24-bit ADC with a 128kSPS rate over four channels. This model offers a higher resolution, which translates to a greater dynamic range and more precise readings [46]. The higher sample rate allows for capturing more data points, which can be particularly beneficial when analyzing the quality of power signals and detecting minute frequency deviations. Despite its fewer channels, the ADS131A04's performance in high-resolution sampling could provide the accuracy needed for critical measurements in our GSFD.

The ADS131E08 extends the channel count to eight while maintaining a 24-bit resolution. It samples at a lower rate of 64kSPS, which is adequate for continuous monitoring but may limit the ability to detect rapid changes compared to the ADS131A04 [47]. This ADC is tailored for power monitoring and protection systems, implying stability in readings, which are essential attributes for maintaining grid stability.

Finally, the ADS1258 presents a combination of high resolution at 24-bits and a substantial sample rate of 125kSPS, similar to the ADS1158 but with an improved resolution. With 16 channels, this ADC stands out for applications that require both high-resolution measurements and the ability to monitor multiple signals. Its architecture ensures that rapid channel scanning and sequencing are possible, which can be advantageous for complex systems that need to analyze several parameters concurrently [48].

We initially leaned towards the ADS131E08, valuing its balance between channel count and resolution. However, further research revealed that the ADS131A04, despite offering fewer channels, provides a higher sampling rate, which is necessary for our application where the quality and speed of data acquisition take precedence. Since our GSFD requires monitoring a limited number of signals, the four channels provided by the ADS131A04 are sufficient, and the higher sample rate ensures that we can detect even the smallest fluctuations in grid frequency, aligning with our project's aim to stabilize the grid effectively. Thus, we decided to proceed with the ADS131A04 for its optimal blend of high-resolution, speed, and sufficient channel count for our specific application needs. Then after further testing, we realized that the on-board ADC from the MSP430F5529 exceeded our expectations and was more than capable of doing the required tasks, so we chose to use it for our final product.

Part Number	MSP430F529 on-board ADC	TI ADS1158	TI ADS131A04	TI ADS131E08	TI ADS1258
Resolution (bits)	12	16	24	24	24

Sample Rate (Max)	244kSPS	125kSPS	128kSPS	64kSPS	125kSPS
Input Channels	14	16	4	8	16
Cost	N/A	\$14.65	\$4.82	\$8.30	\$10.16

Table 13: ADC Selection

3.2.13 Microcontroller

The microcontroller is a typically a crucial part of any design that makes use of one. It is the part that controls the communication and handles the calculations for external devices or components. When deciding what microcontroller to go with for our project, we have taken a few things into account. The number of external devices we would be using, how many GPIO pins we will need, how familiar we are with the microcontroller, communication channels, and many other things have been taken into consideration. The main function of our microcontroller will be to communicate with our frequency sensor, relay switch, and our user interface, which will be a touch screen display. In the following sections, we will discuss four different microcontrollers and their capabilities in terms of this project. The microcontrollers are MSP430, ESP32, Arduino, and Raspberry Pi.

3.2.13.1 MSP430

The MSP430 microcontroller family, known for its ultra-low power consumption, provides an excellent foundation for energy-efficient applications. In a scenario where frequency readings from sensors are vital for controlling a water heater, the MSP430 can be a suitable choice. Its low power requirements make it ideal for battery-powered systems, ensuring continuous monitoring of frequency data without excessive power drain. Additionally, the MSP430 can easily interface with a relay switch, allowing precise control over the water heater. While it may require additional hardware components, the MSP430 can also be adapted for touch screen compatibility to create a user interface that can display information about what's going on with the water heater and allow user interaction. With support for communication channels like UART, SPI, and I2C, the MSP430 can efficiently receive frequency data from sensors and transmit control signals to the relay switch. This makes it an excellent choice for applications requiring low-power, precise control, data acquisition for water heaters, and touch screen interactivity.

3.2.13.2 ESP32

The ESP32 offers both the processing power and communication capabilities necessary for frequency-based control of a water heater. Its support for Wi-Fi and Bluetooth connectivity means that it can receive frequency data wirelessly,

allowing for remote monitoring and control. The ESP32's multiple communication channels, including UART, SPI, and I2C, enable easy integration with relay switches, facilitating precise control over the water heater based on the incoming frequency data. Its compatibility with touch screens and web servers also allows for user-friendly interfaces for monitoring and interacting with the water heater. The ESP32 is well-suited for applications where remote access and control are essential, and its compatibility with relay switches, versatile communication options, and touch screen capabilities ensures efficient and responsive management of the water heater. This would be a great option if we went through with our stretch goal of implementing an app.

3.2.13.3 Arduino

Arduino, characterized by its simplicity and versatility, is also a strong contender for managing frequency-based control of a water heater. Arduino boards offer numerous digital and analog pins, making it easy to connect and read data from frequency sensors. While it doesn't necessarily provide communication channels in the same way that the other microcontrollers do, the GPIO pins can be configured to receive information. When combined with a relay module, Arduino can efficiently control the water heater, allowing it to respond to the received frequency readings. With an extensive library and community support, Arduino simplifies the development of this kind of system, making it accessible to a wide range of developers. Arduino's compatibility with relay switches ensures accurate and real-time control of the water heater based on the received frequency data. It can also be adapted for touch screen compatibility, making it a comprehensive solution for applications that demand ease of use, adaptability, efficient communication, and user-friendly touch screen interfaces.

3.2.13.4 Raspberry Pi

Raspberry Pi, functioning as a single-board computer with a full operating system, provides a robust platform for managing complex tasks. With plenty GPIO pins and support for various communication protocols, it can easily integrate frequency sensors and relay switches into a comprehensive system. Raspberry Pi's capabilities extend to creating user-friendly touch screen interfaces for real-time monitoring and control, making it an excellent choice for applications where user interaction is essential. Its ability to run more advanced software and handle data processing tasks enhances its potential for managing a water heater efficiently based on received frequency readings. The Raspberry Pi's compatibility with relay switches, in conjunction with a variety of communication channels such as UART, SPI, and I2C, ensures precise and interactive control of the water heater and touch screen compatibility for user-friendly operation. This makes it an excellent choice for projects that require advanced data processing, interactive user interfaces, and efficient control based on frequency readings.

3.2.13.5 Microcontroller Comparison

Microcontroller	Manufacturer	Cost	Programming Language	Power Supply Voltage
MSP	Texas Instruments	~\$13-\$25	C/C++	3.3V
ESP32	Espressif Systems	~\$5-\$20	Arduino Sketch(C/C++) <i>or</i> MicroPython	3.3V
Arduino	Arduino	~\$20-\$50	Arduino Sketch(C/C++)	7-12V
Raspberry Pi	Raspberry Pi Foundation	~\$35	Python	5V

Table 14: Microcontroller Comparison

The main factors considered when choosing a microcontroller were the cost, programming language used, and how much voltage it needed to be powered. Two microcontrollers were chosen: MSP430 will be the 'brain' of our device and ESP32 will control our Display.

3.2.14 MSP430

3.2.14.1 Launchpad Integration

Launchpad development kits are tailored for MSP microcontrollers, providing a pre-built environment that's perfect for getting your code up and running quickly. They're particularly useful because they come with built-in features for programming and debugging, which means you can make sure everything's working right before you go to the trouble of soldering the microcontroller onto your own board. Plus, they often include extra testing components like buttons, LEDs, and connectors for expansion modules, which can help in testing different features of your code.

Using a launchpad in the development of our design will save much time and prove to be overall more beneficial and economical. Since Texas Instruments makes both the microcontrollers and the launchpads, they will work well together. This compatibility extends to the software side as well, with the LaunchPads being supported directly in Texas Instruments' Code Composer Studio, where we will write the code for our project. This means you can write your code, debug it, and

flash it all from the same software package, which simplifies the process and will help us get a working prototype quicker.

3.2.14.2 Debugger Integration

In scenarios where MSP microcontrollers do not have accompanying LaunchPads, it is required to flash the code to the MSP using an external debugger. This integration introduces additional considerations into the design process, such as the allocation of physical space on the PCB for debugger connections and the potential implications for the design's cost structure. The necessity for a debugger requires a detail-oriented approach to the PCB layout to accommodate the specific requirements of the debugging protocol.

While an external debugger can offer precise control over system programming and allow for detailed customization, its use also introduces greater complexity and additional expense in the design process. For our GSFD project, this level of detailed system adjustment is not required, and the associated costs and complexities do not justify its use. Our focus is on efficient development and cost-effectiveness, making a Launchpad the preferred choice due to its ease of use and integrated development environment, which aligns well with our project goals.

3.2.14.3 MSP430 Comparison and Selection

The first microprocessor that we looked at for our design was the MSP430F6768 has a processing capability of 25 MHz and 16 kB of RAM, making it good for managing calculations and operations required for monitoring and responding to changes that our readings may have. Given that it has 512 kB nonvolatile memory, it makes it ideal for extensive program storage and historical data logging that could be critical for our design performance analysis over time. The number of GPIOs, totaling 90, allows for a wide range of sensor and input connections, crucial for a responsive and adaptive system such as ours [49].

The MSP430F6769 is another microprocessor that we looked at that mirrors the MSP430F6768 in terms of processing speed and RAM, suggesting it is equally capable of performing intensive tasks. The high GPIO count is maintained, ensuring flexible connectivity. The MSP430F6769's four UART channels offer extensive serial communication capabilities, which could be particularly useful for interfacing with other control systems within the power grid if we chose to, providing a stable setup for data exchange and control signal dissemination [50].

With a lower RAM capacity at 2 kB, the MSP430F6989 might face limitations when dealing with complex real-time data processing, which may be demanded in our design applications. However, 83 GPIOs still plenty of interfacing options. The reduced processing speed of 24 MHz is also factored to consider, depending on how critical the response and detection time is in our design. This microcontroller might be more suited to applications where processing requirements are less demanding. Given that this MSP430 comes with a launchpad it makes it much easier to go about testing and flashing the code to put it on our PCB [51].

The last microcontroller that we compared is the MSP430F5529. This microcontroller provides a balanced option with a 25 MHz clock speed and 8 kB of RAM, supporting real-time applications that are moderately demanding in terms of memory and processing power. Although it has less nonvolatile memory (128 kB) compared to the F6768 and F6769, it should suffice for applications with optimized code and data storage needs. Its GPIO count stands at 63, which will be adequate for our design depending on the number of external components we plan to interface with. It also comes with a launchpad, making it the choice we will use for our design [52].

Product Name	MSP430F6768	MSP430F6769	MSP 430FR6989	MSP430F5529
Manufacturer	Texas Instruments	Texas Instruments	Texas Instruments	Texas instruments
Supplier	Texas Instruments	Texas Instruments	Texas Instruments	Texas Instruments
Price	\$13.16	\$13.16	\$20.00	\$12.99
Frequency (MHz)	25	25	24	25
RAM (Kbyte)	16	32	2	8
Nonvolatile Memory (Kbyte)	512	512	128	128
GPIOs	90	90	83	63
UART	4	4	2	2
I2C	2	2	2	2
SPI	6	6	4	4

Table 15: MSP430 Selection

3.2.15 JTAG Debugger

A JTAG debugger is a very important tool in the realm of electronic testing, debugging, and programming. JTAG debuggers are integral in boundary scan testing during manufacturing, allowing the serial shifting of data through a device's boundary scan register for comprehensive circuit board interconnection testing. Beyond this, the debugger excels in real-time debugging of embedded systems, supporting functionalities such as breakpoint setting, code execution single-stepping, and memory examination and modification. The JTAG debugger plays a key role in in-system programming, enabling the programming and erasure of flash memory in microcontrollers without physical removal. Integrated seamlessly with development environments like Code Composer Studio, IAR Embedded Workbench, or others, JTAG debuggers enhance efficiency and productivity in the development and troubleshooting process.

3.2.15.1 MSP-ezFET

The eZ-FET lite is a low cost USB-based on-board emulation solution for MSP430 microcontrollers. It allows direct interfacing to a PC for easy programming, debugging, and evaluation and provides a USB-to-UART bridge for serial connection to the target microcontroller. The eZ-FET lite on-board emulation is supported by the MSP430 DLL and can be used with IAR Embedded Workbench™ for MSP430 Integrated Development Environment (IDE) or Code Composer Studio™ (CCS) IDE to write, download, and debug applications. The debugger is unobtrusive, allowing the user to run an application at full speed with hardware breakpoints and single stepping available while consuming no extra hardware resources. This debugger is mounted on the launchpads provided by Texas Instruments (TI) and only require the target microcontroller to be using the same power supply and ground along with connecting 2 pins, SBWTDIO and SBWTCK, for debugging.

3.2.15.2 MSP-FET

The MSP-FET (MSP430 Flash Emulation Tool) by Texas Instruments serves as a critical component in the development and testing of MSP430 microcontroller-based embedded systems. This versatile debugger and programmer tool employs the JTAG interface to facilitate seamless communication with MSP430 microcontrollers. Its primary functions include programming microcontrollers by loading firmware and enabling flash emulation during debugging processes. The MSP-FET supports real-time debugging, offering developers the ability to halt execution, set breakpoints, inspect variables, and step through code for efficient troubleshooting. Integrated with Texas Instruments' Code Composer Studio (CCS), the MSP-FET provides a powerful development environment with source-

level debugging, performance analysis, and profiling tools. The MSP-FET also supports a broad range of MSP430 devices such as our own.

3.2.15.3 J-Link Debugger

The J-Link family of debug probes from Segger are another commonly used debugger for embedded systems. These debuggers are widely recognized for their extensive support of ARM cores, but they also offer compatibility with certain MSP microcontrollers, like the MSP430 family from Texas Instruments (TI). This cross-platform compatibility makes J-Link an attractive choice for developers who work with both ARM and MSP architectures. Renowned for their reliability and advanced debugging features, J-Link debuggers provide a valuable toolset for a wide range of development tasks. Their ability to handle complex debugging scenarios efficiently is particularly beneficial for intricate projects where precise and effective debugging is important.

3.2.15.4 Blackhawk USB100/USB200

The Blackhawk USB100 and USB200 are another set of commonly used debuggers for embedded systems, given their compatibility with Texas Instruments' microcontrollers makes them a possible choice for our design. These debug probes are specifically designed to support Texas Instruments' (TI) DSPs and microcontrollers, including the MSP430 family, making them an excellent choice for developers working within the TI ecosystem. The USB100 and USB200 models are known for their performance and reliability. These debuggers offer features like real-time in-circuit emulation, high-speed data exchange, and compatibility with a wide range of TI devices. The USB100 is often selected for its affordability and basic features, making it suitable for smaller projects or educational purposes. In contrast, the USB200 provides more advanced capabilities, catering to more complex and demanding development tasks. Both models integrate seamlessly with TI's development environments and software tools, ensuring a smooth and efficient debugging process.

3.2.15.5 JTAG Debugger Comparison

Debugger	MSP-ezFET	MSP-FET	J-Link Debugger	Blackhawk USB100/USB 200
Compatibility	Designed for MSP430 Microcontrollers	Primarily Designed for MSP430 Microcontrollers	Wide compatibility with various ARM cores	Primarily supports Texas Instruments DSP and

				microcontroller s
Performance	Good for MSP430 debugging	Good for MSP430 debugging	High-speed debugging, industry leading with ARM cores	Reliable performance for TI devices
Features	Provides USB-to-UART bridge for serial connection to PC	Includes energy measurement/software breakpoints	Unlimited breakpoints in flash memory and JTAG support	Event Tracing, JTAG support, advances emulation
Advantages	Comes with the launchpad from Texas Instruments	Optimized for MSP430, Direct support from Texas Instruments	Wide compatibility, High-speed debugging, Good software support.	Works well for TI DSPs and microcontroller s. Advanced debugging features
Disadvantage s	Target board PCB must have power supply and the 2 JTAG pins.	High Cost and requires purchase of target board to mount the chip	Higher Cost	Specialized for TI products

Table 16: Debugger Comparison

3.2.16 Display

3.2.16.1 LCD

In our project, we have decided that we wanted to incorporate a user interface so that the user will be able to see what is really happening instead of just plugging in our device and letting it go to work. With that in mind, we decided to use a liquid crystal display (LCD) to convey information to the user. Some information that will be displayed is frequency, current, and how many times the water heater has been turned on/off by our device. These next sections will discuss the types of LCDs we considered.

3.2.16.1.1 Segmented

A Segmented display is the display often used in calculators and digital watches. This type of display consists of multiple LEDs that can be programmed to light up in specific combinations. While this type of display is great for simple applications, it has its limitations. The major constraint for GSFD in using segmented displays is the limited amount of information that can be displayed on the screen at one time. For GSFD, we are trying to display a lot of data at once in a high resolution. This information includes detailed information about grid frequency, complex and fluctuating electrical statistics such as voltage and current. Another issue with the segmented display for our project is user intractability with the device. For these reasons, a segmented display will not be considered in our design choices [53].

3.2.16.1.2 TFT

These displays feature liquid pixels like standard LCDs but are distinguished by an added thin transistor layer, classifying them as active-matrix LCD technology. The advantages of TFT LCDs include superior image sharpness, producing high-definition images without blurriness. They are also known for their energy-efficient operation, consuming less energy than many other display types. Additionally, TFT LCDs offer fast refreshing rates, leading to smoother images due to their quicker ability to refresh and change images.

However, there are drawbacks to TFT LCD technology. Firstly, they are generally more expensive than traditional LCDs. The cost can vary based on factors like screen size but generally remains higher than standard LCDs. Another problem is the need for separate backlighting. Unlike some displays with self-illuminating pixels, TFT LCDs require an external light source to illuminate the liquid pixels. This backlighting layer sits behind the pixel layer and activates upon turning on the display, projecting light through the pixels. This requirement for separate backlighting is a notable design consideration impacting the overall structure and energy consumption of TFT LCDs.

3.2.16.1.3 Resistive Touch

Resistive touch screens employ a layered structure, typically consisting of two transparent conductive films separated by an insulating layer or dots. When pressure is applied, the top conductive layer makes physical contact with the bottom layer, completing a circuit at the touch point. This technology provides high accuracy and is compatible with various input methods, including styluses and gloves. It is also cost-effective to produce. However, it requires physical pressure for input, which can lead to user fatigue during prolonged use, and the multiple layers can reduce screen transparency. While resistive touch screens offer accuracy, they may support fewer simultaneous touch points because it is based off pressure, and it would be difficult for it to pinpoint where exactly each touch point is coming from. This type of LCD would also require the use of an ADC to

convert the analog voltage signal, created when the two conductive layers come into contact, to a digital signal that the microcontroller can read [54].

3.2.16.1.4 Capacitive Touch

Capacitive touch screens rely on the principle of electrical capacitance, utilizing a grid of transparent conductive electrodes on the screen's surface. When a conductive object, such as a finger, approaches or touches the screen, it disrupts the electrostatic field between the electrodes, allowing for touch detection. Capacitive touch screens are highly sensitive and responsive, supporting multitouch gestures and providing excellent image clarity and transparency. Some capacitive touch screens come with an integrated touch screen controller that interprets the changes in capacitance and would work with digital signals to send directly to the microcontroller, so an ADC is not necessary for this type of touch screen [55].

3.2.16.2 OLED

The OLED (Organic Light-Emitting Diode) display offers a wide range of features that could be suitable for GSFD. An OLED display has excellent color representation, wide angle of readability from the user and a high contrast ratio. When choosing a display to be used in the product, various factors must be analyzed. Firstly, is the cost consideration; OLED displays are typically pricey when compared to other traditional displays like the LCD for instance. Another well-known issue is the reliability of the display. If you have ever seen segments of a display with permanent markings this is typically due to a phenomenon called "burn-in". This is prone to happening when the display is used for a considerable amount of time displaying static symbols such as voltage or grid frequency which may not fluctuate for extended periods of time. Finally, another consideration is high energy consumption. The GSFD project is focused on efficient reliable parts for its selection. For these reasons listed above, the OLED display will not be considered in our design choices.

3.2.16.3 Display Comparison and Selection

Below is a table that represents relative strengths and weaknesses in various categories across the four different types of displays researched above. One check mark means it's the least value with respect to integration with GSFD while four check marks means the most value.

These rankings are based on relative characteristics. For instance, OLEDs are known for their high resolution and fast refresh rate but are more expensive. SEG displays are the most cost-effective but offer the lowest resolution. TFTs and LCDs balance between these extremes, with TFT generally offering better performance than standard LCDs but at a higher cost and power consumption.

TYPE	SEG.	OLED	LCD
Resolution Quality	√	√√√√	√√
Cost	√√√√	√	√√√
Power Consumption	√√√√	√√	√√√
Reliability	√	√√	√√√√
Refresh Rate	√	√√√√	√√
External Backlight	√√√	√√√√	√√√√

Table 17: Display Type comparison

By adding the values from the above table, the correct choice for GSFD is the Liquid Crystal Display (LCD). There are a few key factors that weigh more on the decision over others regarding our final selection. LCD displays are well known for having a high value to performance ratio. As budget constraints are a factor in this project that is a huge benefit.

From a performance standpoint, LCDs are renowned for their ensured reliability and overall energy efficiency. As we aim to provide a device that has a long-life span with little to no maintenance, reliability is key. While LCDs do not offer the highest refresh rate of the comparison group, it is still adequate to display the required information. With all these factors considered, the LCD is the best option for our project.

3.2.17 LCD Display Types

Thin Film Transistor (TFT) LCD screens, which are essentially all LCDs in production at the current time, are typically divided into three main types. TN (Twisted Nematic), IPS (In-Plane Switching), and VA (Vertical Alignment). Each type offers distinct characteristics, primarily influencing the way images are rendered and displayed. The specific attributes of each type play a significant role in determining their optimal use and the viewing experience they provide. Datasheets do not often directly display these characteristics; however, the type can be determined by viewing specifications such as viewing angle, contrast ratio, color reproduction, and mainly cost.

3.2.17.1.1 TN

TN (Twisted Nematic) LCDs are a type of technology used in liquid crystal displays. Characterized by their utilization of nematic liquid crystals, these panels rely on the

unique property of these crystals being twisted naturally. When voltage is applied, the crystals reorient, allowing controlled light passage. This mechanism is what provides the image formation on TN screens. A standout feature of these panels is their rapid response time which typically makes them a preferred choice in fast-paced visual environments like gaming or dynamic video content. However, this advantage is balanced by certain limitations in color representation and contrast levels. TN displays often exhibit less vibrant colors and lower contrast ratios compared to more recent technologies like IPS or VA panels [56].

Another aspect where TN panels differ significantly is in their viewing angles. The image quality, including color fidelity and contrast, tends to degrade when viewed off-center, an issue that might not be overly problematic for individual use but can be a problem in multi-viewer settings or for public displays, which will likely not be important in the design of our project. Despite these drawbacks, TN panels have maintained popularity, primarily due to how cheap they are. They are more affordable to produce than their IPS or VA counterparts, making them a common choice in budget-sensitive markets. Additionally, their lower power consumption aligns well with energy-saving requirements [56].

3.2.17.1.2 IPS

IPS (In-Plane Switching) LCDs are a more modern advancement in display technology, they provide the user with exceptional color accuracy and wide viewing angles. In these displays, the liquid crystals are aligned horizontally, enabling consistent color and brightness across a broad range of viewing angles. This feature is commonly used in professional settings like graphic design and photo editing, where precise color representation is essential. Additionally, the stability of colors and contrast when viewed from different angles makes IPS screens suitable for scenarios where multiple people are viewing the screen simultaneously. Given that our project display is more for providing information to the customer, there is not a huge need for proper color rendering and resolution.

IPS displays also have some trade-offs. They generally exhibit slower response times compared to TN panels, which might be noticeable in fast-paced needs or high-speed video playback. Additionally, the superior color reproduction and viewing angles of IPS technology come with a higher production cost, leading to more expensive end products [56]. Despite these factors, the popularity of IPS LCDs continues to grow, especially among users who prioritize color fidelity and visual consistency.

3.2.17.1.3 VA

Vertical Alignment (VA) LCDs are notable for their high contrast ratios and the ability to display deep blacks. The key to this technology lies in the vertical alignment of the liquid crystals, which naturally align perpendicularly to the substrates when no electric current is applied. In this default state, the crystals block the backlight, making the screen appear black. When voltage is applied, the

crystals tilt to varying degrees, allowing light to pass through and create the image [56]. This ability to effectively block backlight without power contributes to the rich blacks and high contrast that characterize VA panels.

VA LCD technology also typically offers better color reproduction and wider viewing angles than TN panels, though not quite as expansive as IPS displays. This makes VA LCDs a middle ground between the two, with better performance than TN in terms of visual depth and less color shifting when viewed off-angle. However, VA panels can have slower response times than TN LCDs and may exhibit some ghosting in fast-moving images, which is a consideration for high-speed video or gaming applications. Despite this, VA technology is a popular choice for televisions and computer monitors where the benefits of higher contrast ratios are desired.

3.2.17.2 Interface and Compatibility Options

For choosing an LCD for our design, we felt the selection of an appropriate display was important, but not a top priority in terms of specifications since this is not a product that will likely be interacted with on a daily basis. We have already incorporated efficient communication protocols like SPI (Serial Peripheral Interface) and I²C (Inter-Integrated Circuit) in our design, so we needed a LCD that could interface with these communication channels. These interfaces are not only streamlined for data transmission but also align with our design of minimizing wiring complexity and maximizing space efficiency. The SPI, as explained in detail earlier has higher data transfer capability, which is particularly beneficial for our LCD, as it demands frequent updates when customers are viewing. Conversely, I²C, with its two-wire design, greatly simplifies our circuitry, a critical factor in maintaining the compactness and simplicity of our device.

In terms of power compatibility, our design necessitates that the LCD's operating voltage and power consumption work well with our system's power specifications. Given our project's focus on grid stabilization and energy efficiency we felt this was necessary. If a touchscreen interface is to be included, a capacitive touchscreen might be more suitable for our project. Its responsive nature and multi-touch capability could significantly enhance user interaction, albeit at a higher cost. However, this must be weighed against the potential benefits it brings to the usability of our device.

Additionally, the LCD must be built well enough to operate reliably within the environmental conditions expected for our design. Although we don't expect that the location of water heaters will face any intense temperatures, we did feel that this was something that we should at least keep in mind when choosing our display. This includes considerations of temperature range and physical durability. The mechanical and mounting specifications of the LCD was also be carefully evaluated to ensure a seamless fit into our device's design. Ensuring that the LCD display aligns with these parameters is essential for the overall functionality and reliability of our project.

3.2.17.3 LCD Comparison and Selection

Product Name	ER-TFTM050-2	480*320 MCU SPI Serial TFT LCD	DT050ATFT
Manufacturer	East Rising	Hosyond	DisplayTech
Supplier	BuyDisplay	Amazon	Digikey
Price	\$35.42	\$16.99	\$48
Size	5"	3.5"	5"
Resolution	400x272 pixels	480x320 pixels	800x480

Table 18: LCD selection

After considering multiple LCDs, we were trying to decide between the ER-TFTM050-2 and the TFT LCD from Hosyond. The LCD from Hosyond works with a library called TFT_eSPI that can be used with an ESP32. This library has lots of examples and documentation available online which will make it much easier for the development of our user interface. Not much documentation was found for ER-TFTM050-2, so the Hosyond LCD was chosen.

3.2.18 Power Supply

The power supply is the first critical step for our project. The power supply will provide power to all components of our project and is vital for creating an efficient, safe, and reliable final product. After many discussions we have decided to power our device by one of two options. (1) The device will be powered by batteries. (2) The device will be powered by tapping into Wire (L1 – Black) from the wiring diagram above.

3.2.18.1 Batteries

Initially we decided that batteries would be the best option to power our project because of the constraint that a wall plug may not always be available in areas where electric water heaters reside. Additionally, if we decided to go with batteries to power GSFD, it would alleviate some additional circuitry involved with going for a wall receptacle. On the other hand, batteries come with their own challenges. A first major problem is the need to charge them, customers would need to continuously check the power level of the batteries to ensure continued function of GSFD. Another concern is that Lithium-Ion batteries are extremely explosive, this is a major safety issue. Below we will discuss some of the safety and research behind lithium-ion batteries.

3.2.18.1.1 Lithium-Ion Battery

Lithium-ion (Li-ion) batteries are utilized in various electronic devices and applications, operate optimally and safely when adhering to specific charging protocols and conditions. Traditional cathode materials like cobalt, nickel, manganese, and aluminum typically allow Li-ion batteries to charge to an optimal 4.20V/cell, with certain variations occurring based on specific battery types and desired applications. Overall, Li-ion batteries are widely considered safe to use.

Li-ion batteries experience several stages, notably a constant current and a "topping" charge stage, where full charge is realized once the current drops to between 3-5% of the Ah rating. Charging practices, such as using a topping charge when voltage drops and maintaining a charge rate between 0.5C and 1C, help sustain battery health while enabling efficient charging times of about 2-3 hours. A crucial note is that high charge currents do not significantly hasten the full-charge state, but they do ensure a quicker voltage peak achievement while prolonging the saturation charge period [57].

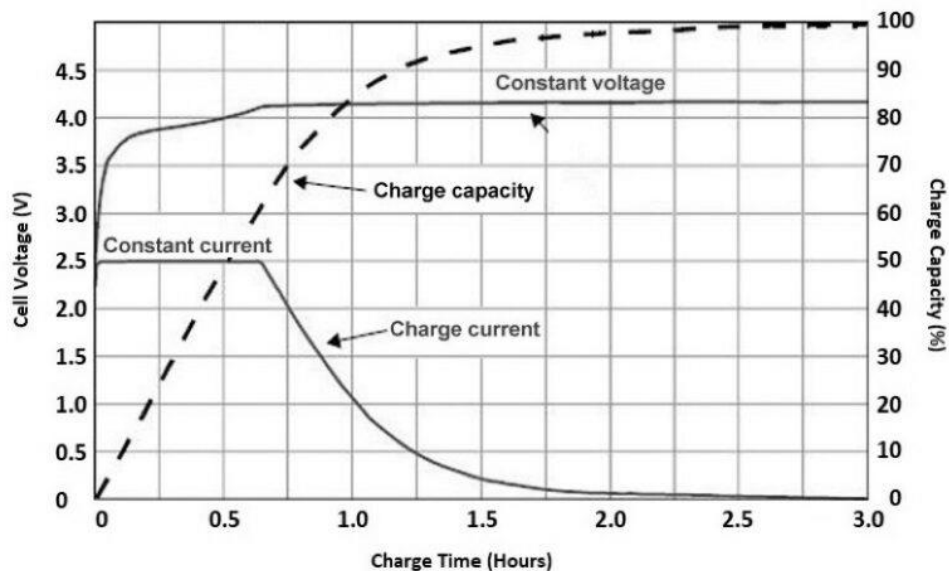

Figure 10: Battery Current vs Charge Time

Increasing the charge voltage can enhance the battery's capacity, but exceeding specified levels can stress the battery and compromise its safety. Protection circuits incorporated into battery packs prevent voltage exceeding set levels to safeguard against potential dangers and damage. Noteworthy is that Li-ion batteries do not necessarily require full charging, and it's typically preferred not to fully charge them, as high voltage levels induce stress on the battery.

Consequently, selecting a lower voltage threshold or omitting the saturation charge can extend battery life at the expense of reduced runtime.

Different charging methodologies are utilized, including simplified “charge-and-run” methods which achieve a state-of-charge (SoC) of approximately 85% in less than an hour without proceeding to a Stage 2 saturation charge. Some industrial chargers purposefully set lower charge voltage thresholds to prolong battery lifespan, and these varied approaches impact the estimated capacities and efficiencies of Li-ion batteries when charged to different voltage thresholds.

A problem with Li-ion batteries is that of overcharging. Li-ion batteries cannot assimilate overcharge and must have the charge current severed once fully charged, as continuous trickle charge could initiate plating of metallic lithium, jeopardizing safety. Strategies to minimize stress, such as allowing the voltage to drop after charge termination to alleviate voltage stress and utilizing brief topping charges to compensate for small self-discharges, contribute to efficient battery management [57].

3.2.18.2 120V AC

3.2.18.2.1 Wall Outlet

If not utilizing batteries to power our project and all of the components, the other viable option was utilizing power from the 120V AC wall receptacle. Since there are so many battery-powered devices that utilize wall plugs to charge onboard batteries via a DC voltage, we knew that we could find an appropriate charging block that would convert the 120V AC power down to a workable DC voltage value to power the microcontroller and PCB components. This could potentially be an off the shelf purchase that we could simply plug and play the generate the necessary power requirements of our project for a low-cost, reliable power solution.

3.2.18.2.2 120V Line to Water Heater

In revising our project, we discovered a more efficient method by deciding to tap into the L1 Black 120v line of the water heater instead of using a wall receptacle or lithium-ion batteries. This approach reduces the overall complexity of the project. By tapping into the 120v line, we achieve two main benefits:

1. Continuous power supply to our device without the need for battery monitoring and recharging
2. Direct and accurate grid frequency readings from the same power source as the water heater.

Consequently, we opted to power our device from the L1 Black 120v line of the water heater, which we determined to be the best solution based on the reasons listed in above sections.

4 Standards and Design Constraints

4.1 Form Factor

- The device's weight should be minimized to ensure portability.
- The device should be designed to be resistant to damage from fine particles like sand and dust.
- For optimal portability, the device's dimensions should not surpass 4" in depth, 7" in width, and 10" in length.
- All components to be insulated to prevent fire hazards and shock to users.

4.2 Standards

- The system shall adhere to OSHA Electrical Safety Standards
- The system shall adhere to OSHA Electrical Codes
- The system shall adhere to Electromagnetic Compatibility Standards
- The system shall adhere to IEEE Electrical Safety Standards
- The system shall adhere to SPI Communication Standards
- The system shall adhere to I²C communication standards

4.3 Electrical Safety Standards (OSHA)

The Occupational Health and Safety organization (OSHA) has set standards to address various hazards such as electric shock, explosions, fires, and potential hazards that may be encountered by workers or pedestrians when working with or around electrical equipment.

These standards primarily focus on the electrical system parts that employees interact with, such as lighting, circuits, high-voltage sources, motors, switches, and appliances. Many of their codes are developed in accordance to established standards from organizations such as (NFPA) National Fire Protection Association and the (NEC) National Electric Code.

The first step listed by OSHA is examination. All electrical equipment shall be examined and thus determined to be free from recognizable hazards that have the potential to or is likely to cause "death or serious physical harm to employees." To determine if the equipment is considered safe, the following procedures must be followed.

4.3.1 Examination

All equipment should be easily identifiable for its intended purpose by precise labeling of all equipment. Equipment that has the intended purpose of enclosing or encapsulating other equipment shall have suitable mechanical strength and durability to provide adequate protection. Electrical Insulation shall be unbroken and bonded to its intended equipment. The potential effects of prolonged or elevated levels of heat are to be considered when examining electrical equipment or devices. Classification by type, size, voltage, current capacity, and specific use. Factors not listed above should also be considered which may contribute to the safety of employees or users that may come into close contact with or proximity to the equipment.

Below is a list of relevant codes produced and published by the occupational health and safety (OSHA) organization.

4.3.2 Installation and Use

The listing and labelling of all equipment shall be used for its intended purpose as stated by the specifications of said equipment. Installations shall be done according to all instructions pertaining to the listing or labeling [59].

4.3.3 Identification of Disconnecting Mains and Circuits

The following standards are relevant to our project because of the potential hazards of handling and interacting with 240v lines of the water heater and the main electrical panel.

Any switches used to disconnect the electrical power for motors and appliances must be clearly marked to show their purpose, unless it is obvious what they are for. Also, every main power source, feeder, and branch circuit must have clear labels near their disconnect switches or overcurrent devices to indicate their function. These labels must be tough enough to withstand the conditions they are exposed to such as dust, heat, currents, wear, and tear via handling.

A disconnect switch is a way to turn off the flow of electricity in a circuit, which is important for safety reasons. By marking these switches and devices, workers can easily identify which circuit they are dealing with and take appropriate actions to ensure safety. If the purpose of a circuit is obvious then specific labels are not necessary [59].

4.3.4 Guarding of Live Parts and Equipment

This standard mandates safeguards for live parts of electrical equipment operating at 50 volts or higher. Our device will be converting 120v to a lower voltage and potentially interacting with the 240v main line of the water heater. These safeguards include approved enclosures, restricted access for qualified personnel,

partitions or screens preventing accidental contact, elevated installations, or balcony/platform placement. In areas where equipment might face physical damage, protective enclosures or guards must be in place [59].

4.3.5 Grounding

This section discusses the importance of grounding in electrical systems and equipment to keep people safe, prevent fires, and protect the equipment itself. There are two main types of grounding [59]:

4.3.5.1 Equipment Grounding

All the metal parts of equipment and enclosures containing electrical stuff are connected to the ground in a continuous and permanent way. Thus electrical currents have a safe path to return to the ground. This also allows protective devices like circuit breakers and fuses to work properly when something goes wrong. Grounding is crucial for safety and the proper functioning of electrical systems and equipment [59].

4.3.5.2 Electrical Systems Grounding

In this type, one part of an electrical circuit is intentionally connected to the earth. This grounding helps protect the circuit in case of events like lightning strikes and keeps the voltage in the system stable under normal conditions [59].

4.4 Electrical Safety Codes (OSHA)

4.4.1 Equipment and Personal Protection

- 1915.181(c): De-energizing the circuit shall be accomplished by opening the circuit breaker, opening the switch, or removing the fuse, whichever method is appropriate. The circuit breaker, switch, or fuse location shall then be locked out or tagged in accordance with § 1915.89.
- 1910.137(a)(2): The equipment must withstand specific AC and DC proof-test voltages for a defined duration. Gloves should also pass a water soak test. Equipment that fails a minimum breakdown voltage test cannot be used for electrical protection.
- 1910.137(c): Electrical protective equipment, especially rubber insulating items, must be maintained in a safe and reliable condition. Specific requirements include maximum use voltages, regular inspections for damage, cleaning as needed, proper storage, and the use of protector gloves in certain situations.

- 1910.335(a)(1)(ii): Protective equipment shall be maintained in a safe, reliable condition and shall be periodically inspected or tested, as required by § 1910.137 [59].

4.4.2 Electromagnetic Compatibility Standards

Electromagnetic Compatibility (EMC) is all about managing electromagnetic interference (EMI) produced by electronic devices. EMI can mess up how nearby equipment works, so EMC helps prevent this interference. It shields sensitive devices like radios and appliances from outside EMI sources, like power lines or motors, so they do not get disrupted [60].

Designing our device with (EMC) in mind is critical to getting accurate output when reading the grid frequency. Failing to do so would result in bad data leading to the water heater shutting off or turning on incorrectly.

Sometimes, multiple devices can add up their interference, causing problems. For example, laptops and mobile phones on an airplane could mess with its systems. EMC ensures that each device limits its interference and can also handle any interference in its surroundings [2].

There are different ways to achieve EMC. Some involve avoiding the source of the problem or reducing its interference. Others use techniques like filtering or shielding to lessen the impact of interference. EMC is like a protective shield for electronics to ensure that they are compatible.

The following testing procedures can be used to test a device (EMC):

4.4.2.1 Radiated Emissions

Radiated emissions testing assesses the strength of electromagnetic fields generated by electrical products, particularly those emissions that are produced unintentionally. These emissions are a natural result of the electrical currents and voltage switches that occur within digital circuits, and they can potentially interfere with other electronic devices or systems [60].

4.4.2.2 Conducted Emission

Conducted emissions testing evaluates the electromagnetic energy generated by a product and transmitted through its power supply cord. The purpose of this test is to ensure that these emissions adhere to the prescribed limits outlined in applicable electromagnetic compatibility (EMC) standards, typically within the frequency range of 150 kHz to 30 MHz. The goal is to confirm that the product's emissions do not exceed the acceptable levels specified in EMC standards during its normal operation [60].

4.5 Electrical Standards and Codes (IEEE)

The following list of standards is sourced from IEEE website. These standards and codes are essential to maintaining safety and overall compliance of best practices.

Powering and Grounding Electronic Equipment:

- This standard provides guidelines for proper power and grounding practices to ensure the reliable operation of electronic equipment and to mitigate electromagnetic interference (EMI).

IEEE 519 - Practices and Requirements for Harmonic Control in Electric Power Systems:

- This best practice focuses on limiting harmonics in power systems to prevent interference with electronic equipment and to maintain power quality.

IEEE 1547 - IEEE Standard for Interconnecting Distributed Resources with Electric Power Systems:

- This standard addresses the interconnection of distributed energy resources, such as solar and wind, with electric power systems, ensuring safe and reliable integration.

IEEE 315 - IEEE Standard for Graphic Symbols for Electrical and Electronics Diagrams:

- States and defines symbols used in electrical and electronics diagrams, aiding in the clear and standardized representation of circuitry.

IEEE 3004.8 - IEEE Recommended Practice for the Application of Human Factors Engineering to Systems, Equipment, and Facilities of Nuclear Power Generating Stations and Other Nuclear Facilities:

- This standard incorporates human factors engineering principles to regulate the safety and efficiency of systems and equipment in nuclear power facilities.

IEEE 602 - IEEE Recommended Practice for Electric Systems in Health Care Facilities:

- Outlines electrical system requirements specific to healthcare facilities, ensuring patient safety and the reliability of medical equipment.

IEEE 45 - IEEE Recommended Practice for Electric Installations

- This standard provides guidelines for safe and efficient electrical installations on ships, addressing the unique challenges of maritime

environments. This standard could be relevant to our project if the design is altered for frequency rectification of electric ships in the future.

IEEE 3001.2 - IEEE Recommended Practice for Evaluating the Electrical Service Requirements of Industrial and Commercial Power Systems:

- This standard helps determine the electrical service requirements for industrial and commercial power systems, optimizing energy use and safety.

IEEE 1202 - IEEE Standard for Flame-Propagation Testing of Wire & Cable:

- Specifies fire safety testing procedures for wire and cable used in industrial applications, ensuring minimal flame propagation.

IEEE 1547 - Standards for Renewable Energy Connection:

- These standards are about connecting green energy sources like solar panels and wind turbines to the regular power grid. They make sure everything works together safely and efficiently.

4.6 Communication Standards

4.6.1 SPI

Serial Peripheral Interface (SPI) stands is widely used for connecting and transferring data between microcontrollers, sensors, displays, and various integrated circuits (ICs). SPI communication plays an important role in applications, offering an efficient and cost-effective solution for exchanging data between devices. SPI is a synchronous serial communication protocol, which allows for full-duplex communication between a master device and one or more slave devices. SPI operates on a master-slave architecture, with the master device controlling the data exchange.

Anything that communicates via SPI will have these four components: Serial Data (MOSI), Serial Data (MISO), Serial Clock (SCK), and Chip Select (CS). The master device will initiate and control data transfer, generating the clock signal and selecting which slave device to communicate with. The slave devices listen for commands and respond via MISO. The SCK signal synchronizes data transmission, and the CS line enables or disables specific slave devices for communication.

SPI communication follows several key electrical characteristics. It typically operates at 3.3V or 5V, ensuring voltage compatibility between master and slave devices. SPI also supports multiple clocking modes, determined by clock polarity (CPOL) and clock phase (CPHA), which specify the clock signal's active state and edge. To be specific, there are four different modes determined by CPOL and CPHA. The CPOL bit is what sets the polarity of the clock in its idle state. The

CPHA bit selects whether the data is shifted/sampled on the rising or falling edge of the clock. This table shows the four different modes that are available.

SPI Mode	CPOL	CPHA	Clock Polarity in Idle State	Clock Phase Used to shift/sample data
0	0	0	Low	Data sampled on rising edge and shifted out on falling edge
1	0	1	Low	Data sampled on falling edge and shifted out on rising edge
2	1	0	High	Data sampled on falling edge and shifted out on rising edge
3	1	1	High	Data sampled on rising edge and shifted out on falling edge

Table 20: SPI Modes

Data order can be transmitted in either MSB (Most Significant Bit) or LSB (Least Significant Bit) order, depending on the application's requirements. Also, it is very common to use multiple peripherals in SPI and this is mainly accomplished by having an individual chip select (CS) for each peripheral. When the master wants to communicate with a specific slave, it enables that slave's chip select and can start communicating. However, if multiple chip selects were enabled, the master would be receiving information on the MISO line from multiple slaves and wouldn't know which information belongs to which slave. An alternate way of working with multiple peripherals in SPI is by daisy-chaining them together. This configuration is mainly used in situations where the microcontroller is only outputting information and doesn't need to receive data, but if data needed to be received, return data will need to pass through all the peripherals before making it back to the microcontroller. Below is a diagram of what the daisy-chain configuration would look like.

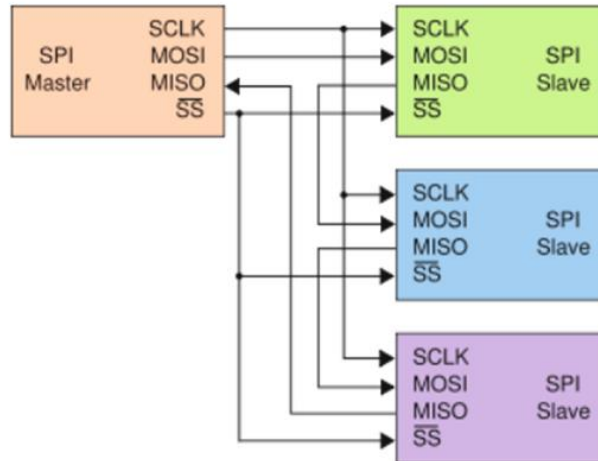

Figure 11: Daisy-Chained SPI Interface

Microcontrollers frequently use SPI to interface with sensors, displays, and memory devices, enabling precise control and monitoring in embedded systems. Sensors such as accelerometers, gyroscopes, and temperature sensors are commonly connected to microcontrollers via SPI, making it ideal for applications in robotics and IoT. SPI is also employed to read and write data to non-volatile memory devices like Flash memory and EEPROM, which are prevalent in data storage and data logging applications. Display interfaces, including LCDs and OLEDs, are often controlled using SPI, enabling high-resolution graphics and fast refresh rates. Some wireless communication modules, like Wi-Fi and LoRa transceivers, use SPI for configuration and data transfer.

4.6.2 I²C

The primary components of I²C communication SDA (Serial Data) and SCL (Serial Clock). The master device initiates and manages communication. Slave devices, which can be sensors, memory modules, or other integrated circuits, respond to commands from the master. The SDA line is used for bidirectional data transfer, while the SCL line provides the clock signal, synchronizing data transfer between devices.

I²C is typically designed to operate at either 3.3V or 5V, depending on the device's voltage compatibility. The pull-up resistors connected to the SDA and SCL lines help maintain the logic levels. I²C supports various data transfer speeds, such as standard mode (100 kbit/s), fast mode (400 kbit/s), and high-speed mode (3.4 Mbit/s), allowing engineers to select the appropriate speed for their application.

In I²C, transmitted messages are broken up into two different types of frames. The first frame is the address frame where the microcontroller specifies which peripheral it wants to communicate with. The address frame is followed by as many

data frames that are needed, and all frames are made up of 8 bits. Data is loaded onto the SDA line when SCL is low and the data is sampled after SCL goes high. Communication is initiated when the microcontroller puts SDA high and puts SCL low. The microcontroller also has a R/W bit that indicates whether it is a read or write operation. After 8 bits are transmitted, whatever device is receiving sends an ACK/NACK (Acknowledge/Not Acknowledged) on the data bus to make sure the data was received.

4.7 Stochastic Controller Constraints for Frequency Regulation

As mentioned before, this project idea is based off of an excerpt published in IEEE Transactions on Smart Grid (Volume: 14, Issue: 5, September 2023) titled “A Stochastic Controller for Primary Frequency Regulation Using ON/OFF Demand Side Resources”, written by Guanyu Tian and Qun Zhou Sun. This excerpt focuses on the idea that residential ON/OFF devices, like various heaters/coolers controlled by a set temperature, can be very useful for helping control the frequency of the power grid. These devices can be controlled in different ways: from a central place, from various distributed places, and locally.

There are advantages and disadvantages to each of these control methods. Using centralized or distributed methods requires a lot of money for setting up communication systems, whereas previous local methods might not work very well because there's no coordination between devices. To solve these problems, the paper suggests implementing a local stochastic controller. The stochastic controller dynamically adjusts the aggregated response power profile by randomizing the execution of demand response actions using a stochastic filter with no communication required. Tests showed that this controller worked very well when used with grid interactive water heaters (GIWH) in situations where the power grid was put under stress simulations.

The principle proposed in the paper is to randomize the response status among ON/OFF devices. The S-DSM (Stochastic- Demand Side Management) controller is composed of mainly two parts: A logic controller and a stochastic filter. It works by measuring the current grid frequency (f) and comparing it to the nominal frequency (f_0). When $f < f_0$ the stochastic controller will produce an off signal, and when $f > f_0$ the stochastic controller will produce an on signal. The stochastic filter is triggered every Δt seconds and produces a random number (denoted by ξ) in the range of $[0,1]$, and the control signal is only executed when $\xi < \alpha$, where α represents the threshold value of devices that must be turned on for the current grid frequency to converge to the nominal value.

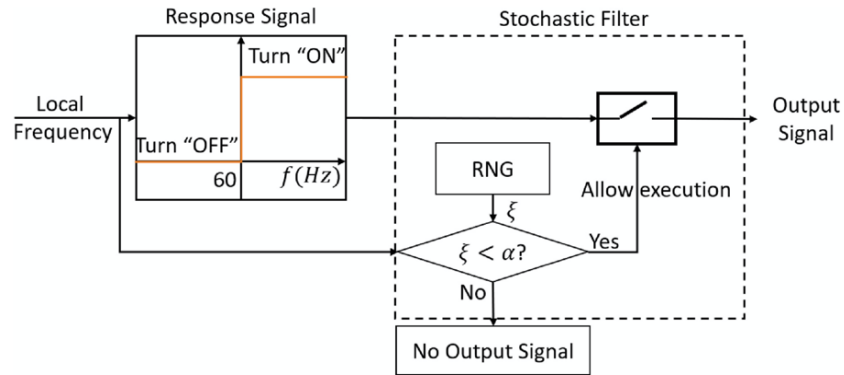

Figure 12: Stochastic Filter Implementation

One of the main benefits of the S-DSM controller is that it eliminates the need to use a frequency dead band, while also improving the system frequency convergence. For simplicity of our project, we will first design a prototype that will rely on a frequency dead band, however, once we get into later stages of development we will then replace this method with the algorithm of the stochastic controller, which is superior given that it guarantees the convergence of frequency to the nominal value exactly, in contrast to deterministic dead band-based controllers that yield constant frequency errors.

This controller was proved to converge at the nominal frequency of 60Hz at all times, starting with the given formula:

$$\dot{\omega} = \frac{1}{2H} (P_m - P_e - D(\omega - \omega_0))$$

Which represents how imbalances in power input and output influence the rotor's speed compared to its desired speed.

Where

- $\dot{\omega}$: Indicates the rate at which the machine's speed (or angular frequency) changes over time (calculated by taking the derivative of ω).
- H: A time constant tied to the machine's inertia, which may indicate how quickly it can respond to disturbances.
- P_m : The mechanical power that the generator produces
- P_e : The electrical power at the generator bus, which is what the generator sends out to the grid; it is the converted form of the mechanical power.
- D: known as the damping coefficient of the generator, which measures how effectively the system can stabilize its frequency in the face of disturbances
- ω : signifies the current speed or angular frequency at which the machine is operating.

- ω_0 : The nominal or target speed of the machine, representing the ideal speed for optimal system performance.

Assuming that line loss is neglected, meaning that we are not considering power losses that usually occur when electricity travels through power lines (due to resistance in the transmission lines as well as other factors), the real power balance at the generator bus labeled P_e is represented as

$$P_e = P_d + rP_r^{total}$$

Where

- P_d : The non-responsive load, which refers to devices or systems that are consistently drawing power and don't change their power consumption based on grid conditions, such as basic lighting or machines that run at a consistent pace.
- P_r : The responsive load, which refers to devices or systems that can adjust their power consumption based on the grid's needs, such as the GSFD.
- rP_r^{total} : Represents the electrical power contributed by the devices that are currently ON in the system.

And depending on the response mode (either under frequency or over frequency) the dynamic model for r is different.

In the under-frequency mode, when the system frequency drops below the desired level(60Hz) the discrete form of r transition (which describes how r changes from one specific time to the next) is represented by the equation:

$$r_{t+1} = r_t(1 - \alpha)$$

Which represents the value of the responsive load at the next time step.

Where

- r_{t+1} : Represents the value of r at the next step in time.
- r_t : Represents the value of r at the current step in time.
- α : Represents the threshold value of devices that must be turned on for the current grid frequency to converge to the nominal value, this is a value between 0 and 1

And

$$\frac{r_{t+1} - r_t}{\Delta t} = -\frac{\alpha r_t}{\Delta t}$$

Which represents the rate of change of the responsive load (r) over time, influenced by the coefficient α . It describes how quickly the responsive load is decreasing from one time step to the next, based on the factor α .

Where

- Δt : Represents the difference in time between two steps, often referred to as the time step or time interval
- $\frac{r_{t+1}-r_t}{\Delta t}$: The rate of change of the responsive load over time
- αr_t : The portion of the current responsive load r_t that's influenced by the coefficient α . The negative sign indicates a decreasing trend.

Finally, we have

$$\dot{r} = -\frac{\alpha r}{\Delta t}$$

Where

- \dot{r} : The derivative of r with respect to time. It indicates how the relative frequency deviation r is changing over time, indicating how fast the deviation is increasing or decreasing.
- r : Indicates how far the current frequency is from its nominal value.

Thus explaining the convergence of the under-frequency response mode for the S-DSM.

The over frequency mode works in a similar way, where we first have the discrete form of r transition:

$$r_{t+1} = r_t + (1 - r_t)\alpha$$

Where the slope of r can be approximated by $\frac{r_{t+1}-r_t}{\Delta t}$ in the following equation

$$\frac{r_{t+1} - r_t}{\Delta t} = \frac{(1 - r_t)\alpha}{\Delta t}$$

And finally, the dynamic model of r can be obtained by

$$\dot{r} = \frac{(1 - r)\alpha}{\Delta t}$$

Note that there are more equations that will prove the complete convergence of the frequency to the nominal value, such as the matrix form of the system dynamic

model in both under frequency and over frequency modes, and more that will not be discussed in this paper for the sake of simplicity.

There are two main settings in which the probability threshold can be in: Constant α and Dynamic α . A constant α value means that regardless of how the system changes or evolves over time, α stays constant and does not change. This setting is beneficial for understanding the system's behavior, however it is not the setting we will be implementing in the GSFD.

The GSFD will utilize the Dynamic α value setting, which is where the α value adjusts itself depending on the frequency deviation from the nominal value. As the system's frequency ω approaches the desired nominal value ω_0 , the value of α reduces. The ultimate aim here is to make α reach zero as the frequency matches the nominal. This dynamic adaptation ensures that in the steady state, the system frequency accurately converges to the nominal value without any persistent deviation.

The implementation of this stochastic controller was simulated in MATLAB under three different conditions; one where 1800 water heaters are equipped with a stochastic controller, one where 2100 are, and one where 2800 are.

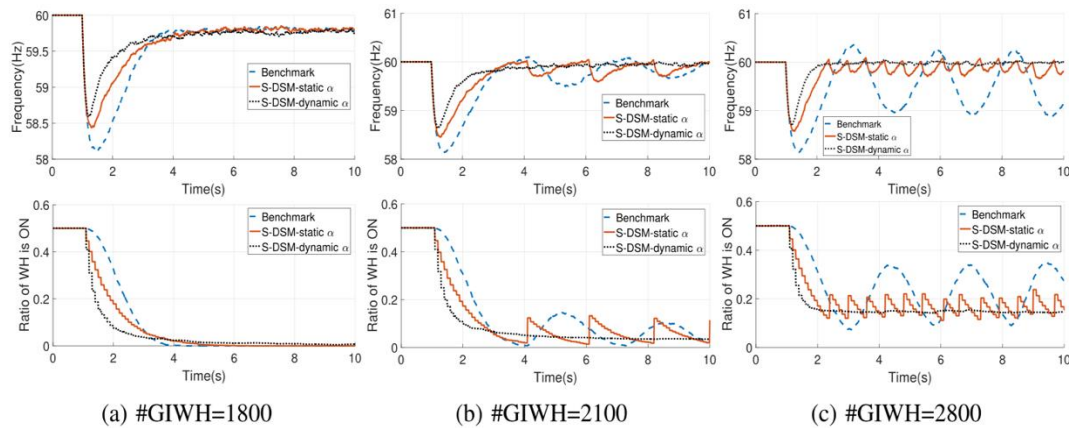

Figure 13: Case Study of 60Hz Convergence

Where you can see that the frequency converges to the nominal 60Hz in every case when a dynamic α value is used.

4.8 User Interactivity and Data Constraints

The scope of this project is primarily designed and implemented from the utility's perspective. The aim of this device is to decrease strain on the grid when the frequency is below nominal values, and to increase the load that the utility sees during brief periods when the predicted load is higher than the actual load, which results in frequencies above nominal values. But we feel that it is also important to

include in this design an element of user interactivity and adequate data to be displayed on the LCD for the user's knowledge. Therefore, we are implementing user constraints that will affect the design and construction of this device.

As consumers and homeowners, we had a pretty good idea of what should be included on the users' end but felt it necessary to get some outside opinions from others. We polled friends, family members, UCF faculty, as well as employees at both Duke Energy and Florida Power and Lighting. Since the usability of this device will be from both the utilities and homeowners' perspective, we felt it important to get a wide range of feedback.

4.9 Consumer Constraints

For the homeowners' perspective, the primary considerations that we heard dealt less with how this device functions and more on how this device benefits them and how it will affect the user both in terms of cost and interference with their existing water heater system. For the utilities' perspective, the primary considerations were grid relief, unit cost and ease of installation.

The first consumer-focused constraint that we evaluated was how this device benefited them. We felt it best to relay these benefits in the form of data to be displayed, specifically cost savings and number of times this device did its job. There were several methods to accomplish this task, but the two primary methods we investigated were a decently sized display with multiple data points, and a mobile phone app. The phone app was something that we felt would give a full and worthwhile user experience but added a lot more complexity to the project compared to the display screen. The information would essentially be the same, but the methods in which the user obtains the data would be quite different, therefore we felt it worthwhile to prioritize device accuracy and functionality over trying to implement the phone app, moving that idea to a stretch goal, and focusing more on the display screen. After deciding to move forward with the display, we added the required interactions with the MCU to be able to communicate with the display, which added constraints on which MCUs we could utilize in this project.

For the information to be displayed, we felt that it was a good idea to display general data points such as voltage levels at the heating elements, current measurements during water heater operation, frequency values, power consumption of the water heater during operation (and possibly cost associated to water heater operation based on user cost per kilowatt hour), and the number of times the device interacted and controlled the water heater. Displaying values for voltage and current can be done easily using analog-to-digital converters which will feed the digitized data to the MCU and then on to the display. Power and cost data can be displayed on the screen by using the voltage, current and cost-per-kilowatt-hour in software coded calculations. The number of times the device has interacted with the water heater can be displayed using a counter. Depending on how we display this information will determine the size and resolution of the display. One final data point that was important for users was the current

temperature of the water within the water heater. This data proves to be more complex to gather and display as tapping into the dual thermostats mounted internally in the water heater (as well as placement and component variations across multiple brands and models) proved to be difficult. Also, the water is at different temperatures throughout the water heater as warm water rises in the tank. These user-requested data points affect the design and construction of this device.

4.9.1 Utility

For the utility-side constraints, we looked at how the unit cost, ease of installation and benefits to the grid affect the overall design and construction. If this device is to be implemented by the utilities and installed as an add-on item, the cost would need to be minimized. This directly affects component selection since a good balance must be achieved between device accuracy and cost. Additionally, ease of installation affects the design as well. If this device can be installed safely by the user, there is more incentive to opt for this device as no additional installation costs are placed on the user. If this device needs to be installed by a licensed professional, this cost will need to be covered by either the user (which could dissuade some) or by the utilities. Finally, device accuracy affects the design process as utilities would not want to adopt such a device if it didn't precisely function to the utilities benefit. Therefore, choice of components and design elements for this project will focus on accuracy and reliability.

4.9.2 End User

Size:

The physical size of this device needs to be large enough to securely encase the PCB, display screen, various small parts, and wiring, etc., but be small enough to be easily mountable near the water heater. The size is considered a minor constraint as the functionality and accuracy is of more importance.

Weight:

The weight of this device should ideally be minimized to aid in installation and mounting near the water heater. This is a minor constraint but one that we feel should not be ignored.

Time:

The time constraints for this project are based around scheduled due dates for Senior Design II. We must diligently stay on track to progress throughout the design process for this project to ensure we are able to construct a working model before the end of the SDII semester.

Compatibility:

This device will be utilized on electric water heaters only. While it would be nice to include gas water heaters as well, they function differently and have no effect on grid frequency to be remedied.

Cost:

The cost of this device should be limited per unit while still providing adequate accuracy of parts and reliability of components, designs, and implementations. For this project, we were given a \$5000.00 USD cap for the design, research and development, testing, simulating, and prototyping. We aim to be way below this ceiling.

Safety:

It is imperative that this device maintains a high level of safety across all components, implementations, and installations. Since this device will be integrated into high voltage, high current settings, it is necessary to follow all safety protocols and procedures during the entirety of this process.

Accuracy:

Given the fact that the discrepancies of grid frequency are very minimal, it is important that this device accurately measures the frequency to a high degree of precision, so that the device functions as intended and relieves stresses on the grid.

5 Comparison of ChatGPT with Other Similar Platforms

Given the rapid advancements of generative artificial intelligence chatbot platforms such as ChatGPT and Bard, we will be determining in what ways these tools will aid our design and report writing.

5.1 Tech Comparison

A beneficial aspect of ChatGPT in our report writing was determining various methods to accomplish a task and comparing different technologies capable of executing those methods. ChatGPT provided insight and ideas on how to implement certain features, presenting viewpoints we might not have considered otherwise. This was particularly useful in exploring technical comparisons of components for our Grid Stabilizing Frequency Detector (GSFD). For instance, when we were unsure about the optimal method to detect grid frequency, step down voltage, protect our circuit, etc.

ChatGPT provided several options along with their potential pros and cons. This not only widened our perspective but also aided in making informed decisions

based on a comparative analysis. ChatGPT along with other chatbots such as googles bard also assisted in benchmarking our design against existing solutions by providing a quick way to gather information on standard practices and state-of-the-art technologies in grid stabilization. This information was instrumental in understanding where our GSFD stands in comparison to existing solutions and identifying areas for improvement.

5.2 Code Debugging and Optimization

Another way that ChatGPT and other AI chatbots will aid in our design is in the programming aspect. Given that not all members in our group have a strong base knowledge in programming, we hope that ChatGPT will be able to provide the necessary help we need in order to get functioning code for our MSP430. ChatGPT can be a valuable resource in this regard, offering guidance on code structure, syntax, and logic. It can help in identifying errors in our code and suggesting fixes to ensure our program runs correctly. If we encounter errors while programming any of the algorithms we must implement on the MSP430, ChatGPT could provide insights on how to resolve those errors. It can also offer suggestions on optimizing the code to run more efficiently, which is key for real-time applications like ours. By optimizing code, we can ensure that our GSFD operates reliably and responds quickly to changes in grid frequency. ChatGPT can also provide references to well-documented and proven code snippets or libraries that can accelerate our coding process. This is particularly beneficial as it could save us time and ensure that we are building our system on a solid code foundation. In situations where we are stuck or unsure of how to proceed, having ChatGPT as a resource can provide a way forward, offering solutions or alternative approaches. This guidance can be very valuable in not only fixing bugs but also in enhancing the performance and reliability of our GSFD.

5.3 Data Analysis Assistance

ChatGPT and similar AI chatbot platforms can also play a substantial role in assisting with data analysis. Given the complexity and volume of data that our system will generate, especially regarding grid frequency and the performance of our stochastic controller, having a tool like ChatGPT can be quite valuable in going through this data to derive insight. ChatGPT can assist in organizing, processing, and interpreting the data, helping us ensure that our output and functionality is correct. For instance, if we collect data on how the GSFD responds to varying grid frequencies, ChatGPT could possibly help analyze this data to identify trends, anomalies, or areas of improvement. It can provide statistical analysis or even suggest suitable data visualization techniques to better understand the data. This is particularly beneficial when presenting our findings to the utility company or in our report, where clear and concise data representation is essential. The platform can also be useful in comparing our data with existing benchmarks or standards in grid stabilization, providing a clearer picture of where our design stands. In cases where we might be unfamiliar with certain data analysis methods or tools,

ChatGPT can provide explanations and guidance, aiding in broadening our understanding and ensuring accurate analysis.

It should also be noted that there are many aspects where AI chatbots such as ChatGPT and Bard should not be used to further our design and report. Here are some examples of when GPT should not be utilized for our project and design.

5.4 Algorithm implementation

When dealing with important information outputted by ChatGPT, we must ensure the correctness and accuracies of the information as these inaccuracies can lead to damaging effects on the design. An incorrect implementation of an algorithm by ChatGPT could cause the design of the GSFD to operate ineffectively or even fail, which is particularly concerning given the precise algorithm implementation required for accurately detecting grid frequency and ensuring appropriate response to grid conditions. Such incorrect algorithm implementation could not only misrepresent the functionality of the GSFD but also result in a failure to achieve the project's primary goal of grid stabilization, affecting the reliability and stability of the electrical grid, and potentially leading to financial or resource losses. These inaccuracies could cause significant setbacks in the project timeline, as additional time would be needed to identify, correct, and re-test the affected parts of the design. Given that this product could eventually be installed in many households, the confidence of this design to function correctly could be undermined if incorrect AI-generated code were to cause design flaws or failures, which could also affect the credibility and the learning experience of the team, especially if the error is not immediately apparent and requires a deep dive to pinpoint and rectify. Therefore, it's important that we dedicate time to verification and validation processes for any critical information or algorithm implementations provided by ChatGPT. Cross-referencing with reliable sources, consulting with experts in the field, and conducting thorough testing are essential steps to ensure the correctness and effectiveness of the algorithm implementations in our design, allowing us to leverage the advantages of ChatGPT while mitigating the risks associated with potential inaccuracies.

5.5 Lack of Creativity

Although there are countless ways to utilize AI chatbots like ChatGPT to our advantage when creating our design and documenting our findings, it's important to note that ChatGPT and similar platforms do not yet possess the creativity inherent to the human mind when it comes to problem solving and devising ways to implement functions in a design. These AI platforms operate based on patterns and information present in the data they were trained on, and while they excel at providing quick answers, generating text based on existing information, and assisting with routine or well-understood tasks, they lack the ability to think abstractly or intuitively, which is often one of the key factors in innovative design processes such as ours. The human mind's capacity for thinking outside the box,

drawing from diverse experiences is something that cannot currently be matched by AI technology. For instance, when faced with a challenge or an unexpected issue in our design, human creativity and ingenuity are the driving forces behind the development of solutions and new approaches. The collaborative brainstorming among team members, the exchange of diverse perspectives, and the process of building upon each other's ideas are integral to the innovative design process, whereas AI chatbots are limited to what has been programmed or learned from previous data and cannot contribute to collaborative brainstorming in a meaningful or genuinely innovative manner.

5.6 Test Case 1

For This Test case we determined the output that ChatGPT would provide if we asked it "Can you tell me about different types of Step-Down Circuits for a Senior Design project I am working on?"

Linear Regulators (LDOs):

- How They Work: They use a transistor to drop excess voltage as heat.
- Pros: Simple, low noise, good for low power applications.
- Cons: Inefficient for large voltage drops, as they dissipate a lot of heat.

Switching Regulators (Buck Converters):

- How They Work: They use a combination of inductors, capacitors, diodes, and a switching element (like a MOSFET) to efficiently reduce voltage.
- Pros: High efficiency, good for high power applications.
- Cons: More complex, can generate noise (EMI).

Pulse-Width Modulation (PWM) Regulators:

- How They Work: A type of buck converter that controls the output voltage by varying the duty cycle of the switching frequency.
- Pros: Very efficient and precise control of output voltage.
- Cons: Complexity in design, noise issues.

Integrated Circuit (IC) Regulators:

- How They Work: These are usually complete buck converter solutions in a single IC package.
- Pros: Compact, easier to use, often includes additional features like overcurrent protection.
- Cons: Less flexible than discrete designs, can be more expensive.

Synchronous and Non-Synchronous Buck Converters:

- Synchronous: Uses two MOSFETs (high-side and low-side) for switching.

- Non-Synchronous: Uses a MOSFET and a diode.
- Pros of Synchronous: More efficient at light loads.
- Cons of Synchronous: More complex and costly.

Multi-Phase Buck Converters:

- How They Work: Uses multiple inductor-capacitor pairs phased out in time to reduce input ripple and improve transient response.
- Pros: Better performance for high-current applications, reduced thermal stress.
- Cons: Complex design, more expensive.

Digital Buck Converters:

- How They Work: Uses digital control for the switching elements.
- Pros: Precise control, programmability, and adaptability.
- Cons: Complexity, potentially higher cost.

Each type has its advantages and drawbacks, and the choice depends on factors like required efficiency, output power, size constraints, and cost. For a grid-stabilizing frequency detector project like yours, efficiency and precision in controlling the output voltage are likely key considerations, so a switching regulator or a PWM-based design might be a good fit. However, if simplicity and noise minimization are more critical, a linear regulator could be the right choice.

5.6.1 Results

This response provided a good foundation in understanding various step-down circuits, particularly focusing on buck converters. It offered insights into different types of buck converters, their working principles, advantages, and disadvantages. This information is highly relevant for applications involving DC-DC voltage conversion; However, the response oversimplified the category of step-down circuits by equating them primarily with buck converters, which are indeed a type of DC-DC converter. This generalization overlooks the broader spectrum of step-down circuits that operate in different contexts. Not all step-down circuits are DC-DC. There are other types of step-down conversions such as AC-AC converters (transformers) and AC-DC converters (rectifiers).

6 Hardware Design

To begin the design process, we first deconstructed our project into subsystems and evaluated each one individually. We thought it best to look at the major components or processes that this device would be doing or interacting with, and then once we got those pieces figured out, we would then break each subsystem down into smaller pieces to establish how each system and component interacts with one another.

6.1 Water Heater Control

Starting from the water heater, we knew we had to interact with it somehow. Looking at the various devices available on the market that can interact with water heaters to some capacity, we quickly realized that many of these devices were brand/model specific. This is something that we wanted to avoid, and therefore thought it best to design a device that could interact with the majority of electric water heaters found in residential homes across the country. Ruling out commercial water heating systems that are generally large 3-phase appliances or boilers, we learned that the most common type of residential water heater was the conventional dual-element (and single-element variants) versions that store water in a vertically oriented cylindrical tank, followed by tankless “on-demand” types, with some newer technology grid-interactive models at the upper end of the price spectrum. As an appliance that doesn’t need regular replacement, millions of older-tech dual-element water heaters are still currently installed across the country, and while being one of the least expensive types to purchase, the continued utilization of this technology is guaranteed to be relevant for many years to come. Given this, we knew we had to design our project around this technology, while maintaining the ability to interact with most brands and models (and possibly newer models not yet released). This instantly ruled out the possibility (at least at this stage of the design process) of interacting with the internal circuitry of the water heater, as this could be vastly different from one brand/model to the next. This left the only viable option of interacting with the power going into the water heating elements. For most dual-element water heaters there are two 120V lines and one return line coming in directly from the 30A circuit breaker located in the load center. Each 120V line connects to either side of the high temperature limiting switch, and then down to one terminal of each heating element. This ensures that both heating elements have one 120V energized terminal at all times unless the high temperature limiting switch or the 30A breaker are tripped. The other 120V Line runs from the other side of the high temperature limiting switch down the upper thermostat. By controlling the power flow to the first 120V line that is connected to both heating elements, we could effectively shut off all power to both heating elements, which could be done with a single solid-state relay. This relay would need a control signal to open and close the connection, which could be provided by one of the GPIO pins from the microcontroller.

6.2 GSFD Power Supply

Next, we looked at how the device would be powered. After researching various methods, we ruled out battery power and found it best to get the power from the 120V service in the house. This decision was made for a few reasons. Firstly, many water heaters are installed in basements, closets, or underneath stairwells, and we felt it best to not rely on batteries that would need to be replaced, as these locations are not often occupied, and we didn’t want to chance this device failing to operate reliably because of dead batteries and relying on the consumer to regularly monitor the battery levels within the device. The other consideration was

that some of the circuitry to be designed might have varying power levels, such as biasing an operational amplifier at a DC voltage above what the microcontroller needs, and we didn't want to rely on larger batteries and higher voltages to supply power to the various active parts of the device. This led to two primary options: utilizing a wall outlet for power or utilizing one of the 120V lines feeding the water heater. As both options required similar levels of circuit design, we looked further into the pros and cons of each method.

Utilizing a wall outlet seemed the more sensible approach as power supplies that would convert the 120V AC signal down to the required DC voltage level to power the MSP are readily available. One problem with this, however, is that while we could purchase a part to power the MSP, we still might need to supply power to other parts of the circuit, at various voltage levels. Another drawback to this option is that where water heaters are generally located, there is often not an accessible receptacle nearby, as these locations are generally unoccupied spaces within the residence. We wanted to ensure that this device would be easy to integrate no matter the size, shape, brand, model, or location of the water heater. This led to considering the option of tapping into one of the 120V lines providing power to the load. Since one line is always energized, we knew we could have continuous power going to our device. While initially we considered this a more dangerous approach, the realization that the 120V line would need to be tapped into anyway to install the switching relay, we knew we could divert that to our device at the same time, provided we design the appropriate circuitry to convert and step down this voltage to a safe and usable levels. This method also allowed us to establish a system that could provide any power necessary elsewhere in the circuit from various steps in the step down and conversion process. The other benefit to this approach is that it allowed our team the opportunity to apply what we've learned as we design and safely implement the necessary circuitry.

6.3 GFSD to Load Connectivity

Now that the two 120V AC components were established, it was time to finish designing how these would interact with the existing wiring. Since the one 120V line connected to the two heating elements would be interrupted and attached to relays two load terminals, with the hot side continuing onto the primary side of the voltage transformer, we had only one other connection the make which was the negative side of the transformer. This would be connected to the ground wire running to the water heater. Considering the installation of this device, we felt it best to create male/female plug pairs to connect this device to the water heater. By severing the single 120V and ground lines between the load center and water heater, we could install male plugs at both severed ends. This would allow us to plug both ends into our device which would connect the relay and transformer to the system.

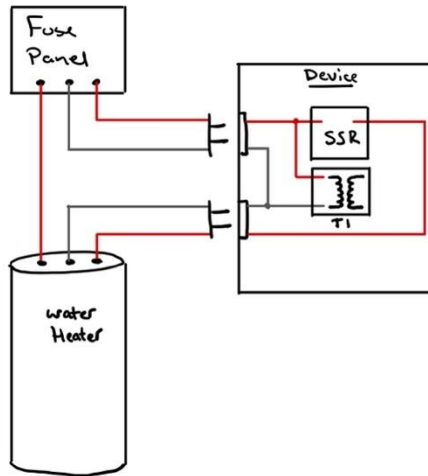

Figure 15: GSFD Connectivity

6.4 Voltage Step-Down Circuit

Once the supply power source was established, it was time to start designing the step-down circuitry that would provide power to the various parts of our device. By tapping into the 120V AC line, we knew we would need to reduce and convert this voltage to be usable. After looking at various methods, we noticed that a flyback transformer circuit could be a viable option. What we needed from this circuit is stable, reliable voltage levels, and a robust method of circuit protection for the sensitive components within the device. Utilizing a transformer was something that provided a cost-effective option to reduce the 120V AC signal. After considering other factors throughout design and other circuitry that might require power, we opted for stepping down the voltage by a factor of 10, which would provide us with a versatile and useful 12V AC signal, more than enough to power any active components we might need elsewhere in the system. While utilizing this transformer would reduce the voltage significantly, the current could go up by the same factor of 10, which would be incredibly dangerous for both the system and personal. Therefore, it was imperative to implement some current-limiting device or circuit on the secondary side of the transformer. Once we had a lower AC voltage to work with, we needed to convert the AC signal to DC, and step it down further to useful voltages, with the ending voltage to be a constant 5V DC that would power the MSP. To convert the AC signal to DC, we thought it best to use a half-wave rectifier circuit to remove the negative portions of the sinewave. Once the signal was rectified, we needed to implement some conditioning and filter to the waveform. This came in the way of utilizing a capacitor that would be tied to ground. By finely tuning the capacitance value, we could alter the ripple voltage waveform coming from the secondary side of the rectifying diode bridge. As the capacitance increases, the output waveform would converge to the input signals amplitude minus the voltage drop across the diode. The next thing that would need

to be done is to implement some form of voltage regulator. There were two options here for the regulation, we could implement a purchased part, such as the TI LM7805, which could output our desired 5V DC, or design our own regulator. After some simulations and calculations, we devised a circuit segment with a resistor, capacitor, and Zener diode could be implemented to achieve the desired output voltage, so long as the load impedance was between 700 Ohms and infinite resistance. This would be a cost effective, easy to design and implement, and most of all reliable method to generating a DC waveform. However, due to the reliance on the MSP430 to operate reliably, we opted for utilizing the LM7805 so that we could benefit from the voltage regulator's built-in input/output protection and reliable voltage delivery.

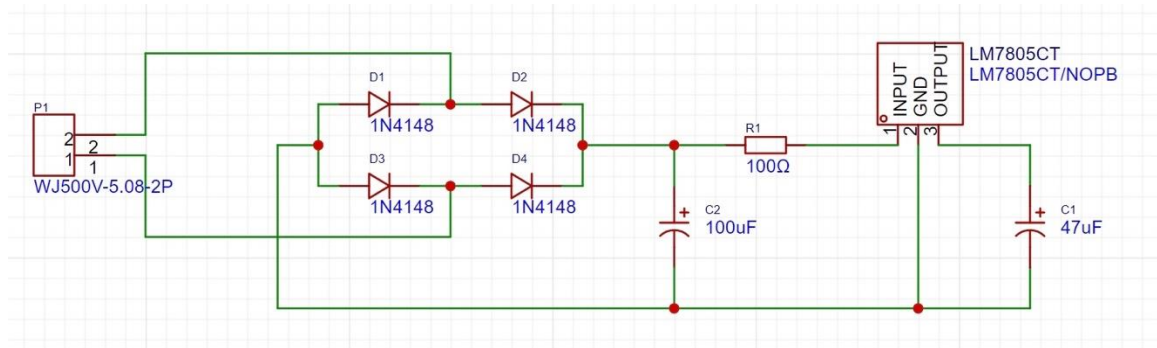

Figure 16: 12V ac to 5V DC step-down circuit

6.5 Voltage Data

Next, we looked at all the data measurements that we needed to acquire to use for both the decision-making process for on/off operation as well as calculations for other data points such as power calculations that could be displayed on the LCD. There were four main pieces of information that we needed to gather: frequency, voltage, current, and temperature. After researching the numerous technologies, methods, and parts that we could utilize, we started designing how we were going to acquire and transfer these values to the MSP. First, we looked at the voltage as it was likely to be the easiest to obtain. Since we already had a transformer to step down the 120V AC signal to 12V AC, we thought it best to start our voltage measurement from this point. With the design of our 12V AC to 5V DC power already consisting of a half-wave rectifier diode, we had the option to utilize this node to feed voltage information to the ADC through additional filtering, however, we felt it best to entertain other options. The primary reason for this was that the node at that point had no previous protection devices in place, and we also wanted to maintain isolation between our MSP430 power supply and other subsystem circuits within the system. This led to backtracking to the 12V AC signal from the secondary side of the transformer and the design of a new voltage-

measurement circuit. Starting from the 12V AC sinusoidal input, we knew we had to rectify the signal somehow as the ADC we chose doesn't accept a wide range of negative values, so we opted to create a bridge rectifier circuit to convert the negative portion of the input waveform to all-positive values. Next, we referenced the datasheet for the ADC and noticed that the maximum voltage for the input channels was 3.3V, therefore we needed to step the voltage down to a safe and usable amplitude. These two things were done utilizing a full-wave bridge rectifier, where the output signal was then conditioned with a filtering capacitor, and then fed into a voltage divider circuit. The input impedance for each channel on the ADC is 130K Ohms, so we just needed to find the appropriate ratio to step down the voltage to under 3.3V. Once the output waveform was established, we could then reference the input voltage by adding back on the diode voltage drop, and then multiplying by the voltage divider ratio. The only other consideration was the limited input current rating of the ADC of 10 mA, which would be controlled during testing using a series current-limiting resistor and voltage divider made up of the series resistor and input impedance of the ADC.

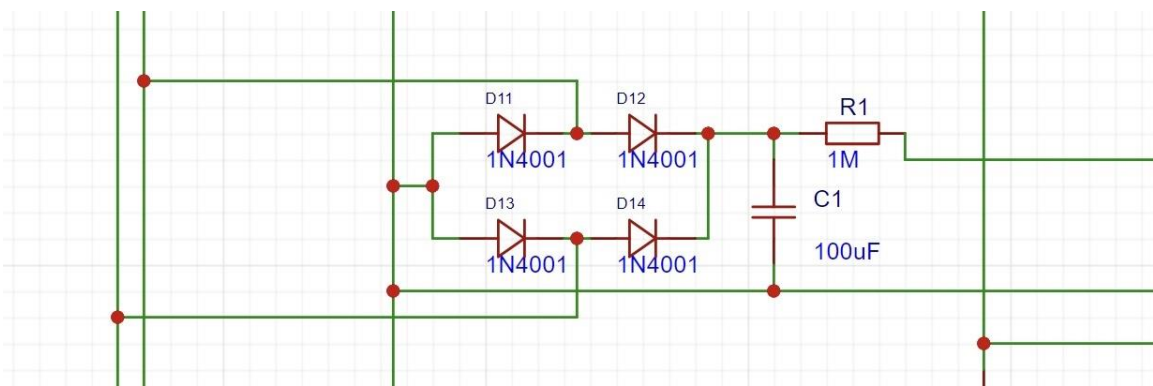

Figure 17: Voltage Sensing Circuit

6.6 Current Data

In our design, we obtain current readings using a current transformer (CT), which operates on the principle of electromagnetic induction. As discussed previously, the CT measures the current flowing through the primary coil, which typically consists of a single turn, and produces a proportionally lower current in the secondary coil. This step-down effect allows for safer and more manageable measurements [15].

However, it's important to note that current transformers typically output a current, which isn't directly compatible with analog-to-digital converters (ADCs) that require a voltage input. To address this, a burden resistor is placed across the secondary of the CT. The burden resistor, or load resistor, converts the secondary current

into a voltage that can be measured by the ADC. The value of this voltage is proportional to the current flowing through the primary coil and the resistance of the burden resistor.

Using a burden resistor and converting the output to a voltage is beneficial for our design because it allows the ADC to measure the current indirectly. since ADCs are typically designed to read voltage levels, not currents, so this step is needed in order to interface the CT with the rest of our digital system. By choosing an appropriate burden resistor, we can ensure the voltage stays within the ADC's input range, enabling accurate and reliable current measurements for our application.

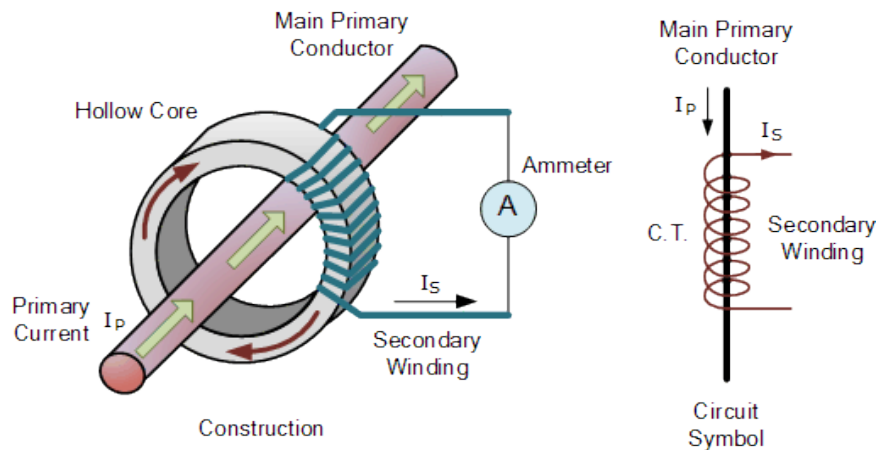

Figure 18: Basic Current Transformer Diagram

Reprinted with permission from Electronics Tutorials

The chosen CT for this project included a burden resistor within its circuitry, so we then moved on to designing a subcircuit to convert this output waveform so that we could read the frequency. With the output already a voltage value proportional to the current, we wanted to design a rectifier circuit that closely matched the output waveform's magnitude to the input magnitude. For this reason, we opted for an op-amp based rectifier circuit to alleviate any diode voltage drops found in traditional diode rectifier bridges. Since the input voltage could be below the turn on voltage of the diode, we wanted to ensure that the entire input waveform could be processed, so utilizing a diode rectifier was not an option.

Starting with a precision op-amp rectifier using reversed diodes in the feedback loop, we were able to capture two signals coming from the input waveform. The first was generated during the positive half of the input sinusoid which creates a

half-wave rectified signal. The second was generated during the negative half of the input sinusoid and creates another half wave signal with one-half amplitude. Sending both signals into a summing amplifier with a gain of two, creates the second stage of this circuit. Finally, the output of the second stage is conditioned using a filtering capacitor and a buffer stage.

Since our current transformer has a linear relationship between the current in the measured conductor and the output voltage, we were confident that we could establish an accurate current measurement to be displayed on the LCD. And since the maximum output voltage of current transformer was 3V at 30A, we knew that no other conditioning and manipulations were needed before the signal was fed into the ADC. Since we were utilizing an active component for this subcircuit, we needed to provide a bias DC voltage, so we utilized the 5V power supply voltage for this purpose. The positive 5V signal was fed to the Vcc+ on the op-amp, and an inverting unity-gain buffer to supply a negative 5V signal to Vcc-. Finally, this output signal was processed through a voltage divider with a ratio capable of reducing the amplitude to under 3.3V.

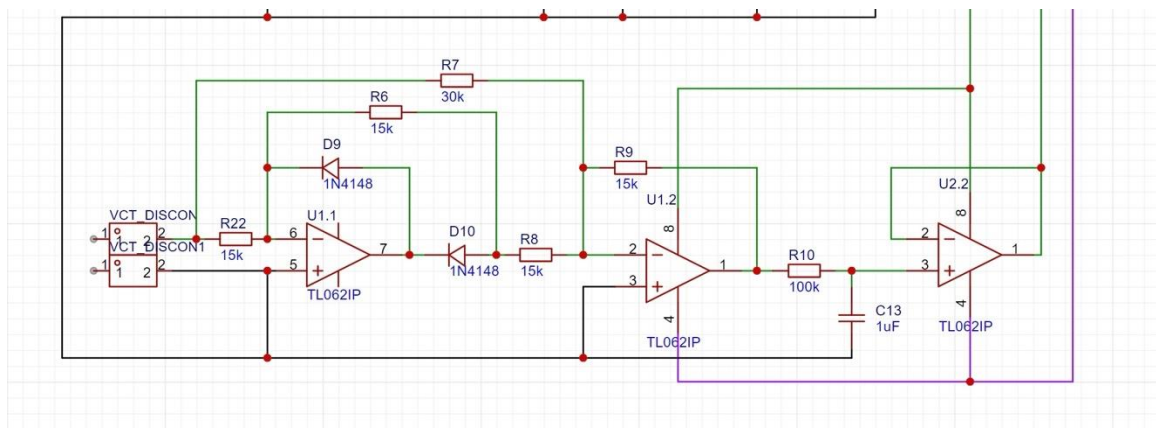

Figure 19: Current Transformer Output Circuitry

6.7 Temperature Data

One of the sponsor requests was to have the ability to measure the temperature within the tank and present that data on the display. To accomplish this task, we started looking into the various ways to gather temperature data from the water heater. The most direct method would be to tap into the onboard temperature sensors within the two thermostats of the water heater. However, this would prove difficult to implement across all brands and models, as some sensors may be more easily accessible, while some may be covered or difficult to tap into. Since our objective for this project was to maintain applicability across all brands and models, this option was not going to work for us. Next, we looked into other temperature

sensors that could be retrofitted to any water heater. Some products on the market that could accomplish this task were available, including probing sensors insertable into the pressure relief valve. Again, this direction could pose problematic in that it would involve interfacing with the water heater to a deeper level than we would like.

There was also the risk of changing the functionality and reliability of the pressure relief valve itself, which could prove to be dangerous. After examining the various ways we could get a temperature reading, we realized that water heaters are surrounded by insulation everywhere except where the two onboard thermostats are mounted to the outside wall of the inner water tank. Since household water contains minerals and contaminants, the thermostats (and temperature sensors) on water heaters are non-contact and do not reside inside the water tank. Given this information and the fact that the tank is insulated so well, finding a surface-contact temperature sensor and placing it directly on the hot output water line, could give us a temperature reading very close to the actual temperature of the water at the top of the tank. While the minor discrepancy was initially thought to be problematic, we decided that it was not enough to prevent moving forward with this direction. One of the primary reasons for this was that the temperature of the water inside the water heater is not only constantly changing, but is also not the same at different parts of the tank. As the warmer water at the top of the tank is being used, cool water flows into the tank at the bottom, and the heating cycle continues. Once the water in the top reaches its nominal value, the bottom element is energized to try and maintain consistent water temperature. However, there are still always differences in temperature depending on where you are inside the tank, so we felt that a general temperature reading was accurate enough for this application.

After careful consideration of the various types of temperature sensors, we ultimately opted for a 2-wire RTD Pt100 sensor. We purchased two versions of this type of sensor for testing and demonstration purposes. The first is a contact sensor with a sticky pad which can be demonstrated by attaching to a surface, and heating that surface up and comparing the temperature reading with an infrared temperature sensor gun. The second type was a probe sensor that could be demonstrated by placing in water, and comparing the temperature reading with a probe thermometer.

6.8 Frequency Data

When beginning the design phase for the frequency data, we knew it was imperative to get an accurate and reliable reading. As the GSFD is reliant on the frequency to interact with the water heater, we needed to establish a way to obtain a precise reading that could update in real time to the MSP430. Since both the voltage and current coming from the load center are sinusoidal, we knew we needed to establish a way to gather frequency data before either of those waveforms were converted to DC values throughout the circuit. Since frequency could be read from either the voltage or the current, we then thought about the

design and where could get a reliable reading from. Since the current waveform going through the SSR would only be available to extract when the switch is closed and one of the two heating elements were on, we thought it best to use the voltage signal as the AC voltage sinusoid would be present whether the circuit was open or closed. Since we were tapping into the 120V line to power the primary side of the transformer, we thought it would be a good idea to tap into this path somewhere on the secondary side because there would always be a waveform unless the breaker in the load center was tripped. Since this circuit design would be constructed on our PCB, we wanted to ensure it was protected, so decided to create a branch from the secondary side of the transformer, after the circuit protection system, to gain our frequency reading.

After looking into the various ways to determine frequency of a sinusoidal waveform, we decided that a zero-crossing method would be the best choice for this application. The information that we send to the ADC to sample and quantize this data needs to be positive values only, so we opted to rectify the waveform with a full-wave bridge rectifier. This is a tried-and-true method for mirroring the negative component of a sinusoidal waveform centered about the Y-axis at zero, to create a positive-only waveform. Next, we needed to manipulate the output of the bridge rectifier so that the ADC could accurately and precisely process this information. Therefore, we opted to create a circuit that would output a pulse, or spike, every time the input waveform crossed the zero axis. This was accomplished by utilizing a transistor at the output of the circuit. By connecting the secondary side of the transformer to the base of an NPN transistor, and feeding the transistor collector a steady 5V DC, we were able to create a pulse between the collector and ground each time the input waveform passed zero. This new output waveform was then sent to the ADC to be processed, and finally to the MSP430 where the software code could evaluate the data and precisely determine the frequency of the input signal. Keeping with the maximum voltage input rating for the ADC, we again utilized a voltage divider based on the 130k Ohm input impedance to create a voltage divider, which would allow a periodic pulse with a safe amplitude.

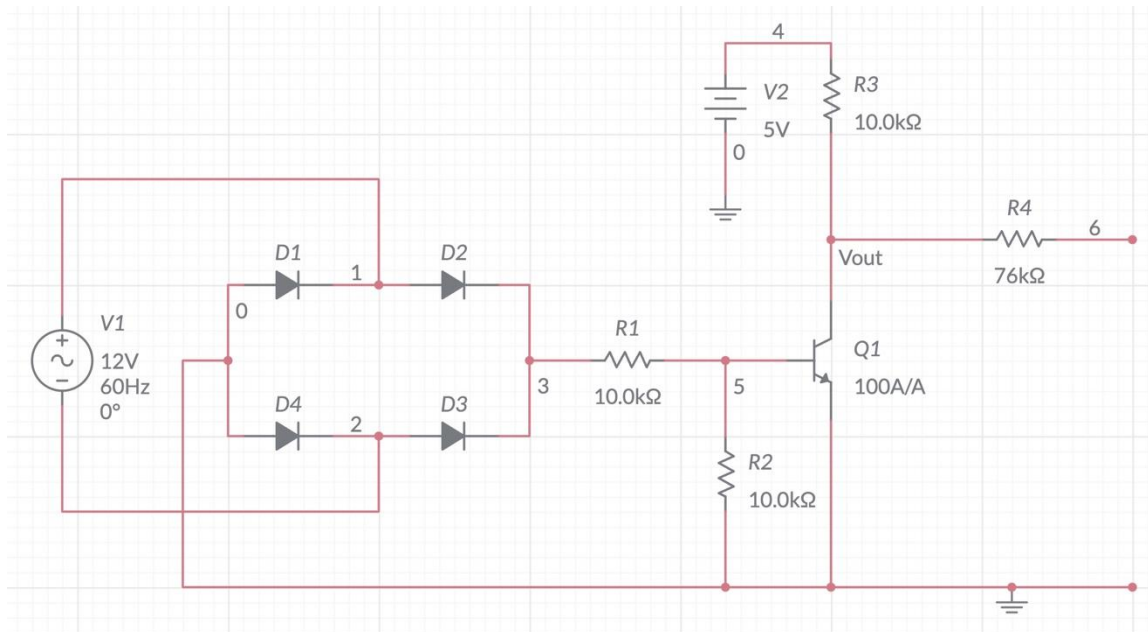

Figure 20: Zero-Cross Detection Circuit Utilizing NPN transistor

6.9 Subsystem Interconnectivity and Power Flow

With the bulk of the subsystem circuits being designed, it was time to think about how each subsystem would interact with one another, as well as how each system would be connected to and communicate with the MSP, ADC, and other components on the PCB.

Starting from the 120V AC line coming in via a 3-pin plug that would be inserted into the GSFD encasement, we connected this to a bus mounted on the inside of the GSFD, which would connect the load center to both one load terminal of the SSR and the primary side of the transformer. The other load terminal of the SSR would connect to another female 3-pin plug that would ultimately go to the water heater. The ground wire coming in from the load center via 3-pin plug would be routed to a ground bus mounted inside the GSFD and would then be connected to the output via another 3-pin plug. This completed all 120V AC connections to our system. Next, we established another set of bus bars to connect the secondary side of the transformer to. These would then branch of to both the power supply PCB, and the main PCB via terminals. With the power supply PCB being a stand-alone circuit, we there were no other connections except the reference ground and 5V outputs, which would be connected via terminals to the main PCB. With the 12V and earth ground terminals on the main PCB, we then branched these two nodes to both the voltage measurement rectifier circuit as well as the frequency detection circuit, with a TVS diode at each positive subcircuit input for protection. With both of these powered, the outputs of each would then be fed into two separate channels on the ADC. For the temperature sensor and current transformer, we included additional sets of screw down terminals for both sensors;

three for the current transformer's positive, negative and ground wires, and four for the temperature sensor's positive, negative, SCL, and SDA wires. The Current transformer terminals would then be connected to the current measurement rectifier subcircuit via the positive and negative, while the transformer's ground wire would be connected to the ground bus. The output of this circuit would be fed into a second channel on the ADC. Next, the 12V signal from the bus was fed into another rectifier circuit for gathering the frequency data. The output of this circuit would be fed into another voltage divider to control the amplitude and bring it down to under 4.5V so that it could be fed into a third channel on the ADC.

Once the subcircuits had been established, we then finalized the hardware design by having the ADC connect to the MSP via four wires for SPI communications. As with the MSP, the ADC would also need a reference voltage that would be supplied by the 5V DC supply.

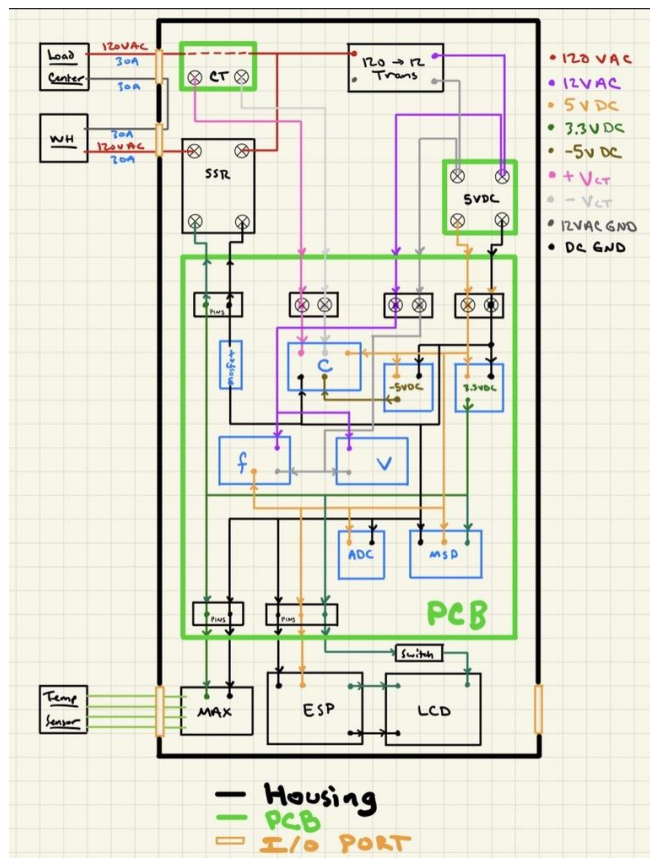

Figure 21: Power Flow Diagram

6.10 Housing

6.10.1 Construction

The housing is 3d printed using black ABS plastic. There are two pieces that make up the house; a back plate with integrated shelf to mount all components and PCBs, and a removable lid with a cutout for the LCD and input/outputs.

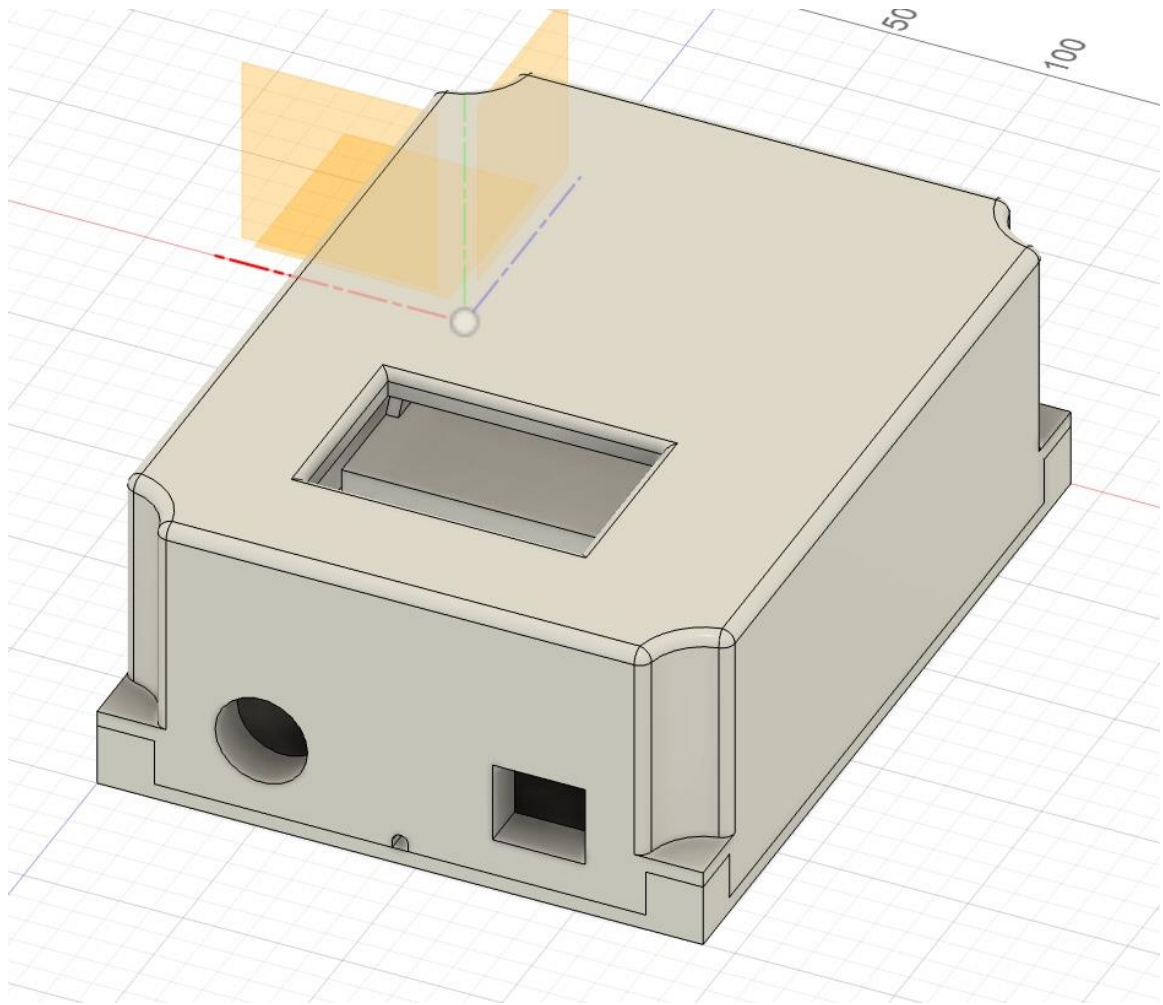

Fig. 22: Housing Design

6.11 Sponsor Considerations

This project idea was originally formed by Dr. Guanyu Tian and Dr. Qun Zhou Sun and allows us to get hands-on involvement in the development of smart grid solutions in the power industry.

A main aspect of this project that Dr. Guanyu Tian requested we integrate is a temperature-sensitive control mechanism. This entails reading the current water temperature of the water heaters and utilizing this data to determine which water heaters to shut off based on the grid's stress levels. The goal is to ensure that if a customer's water heater temperature is closer to the lower level of the defined dead band, the water heater remains operational to avoid any discomfort to the user. On the other hand, if the water temperature is at the higher end of the dead band, shutting off the water heater is considered more appropriate. Achieving this level of control can be achieved two ways: By tapping into the internal controls of the water heaters to accurately monitor the water temperatures, or by installing a separate temperature sensor inside the water heater.

Another aspect requested in our design of this project is the implementation of an interactive user interface. This interface, equipped with a touchscreen display, aims to provide users with essential information such as the current grid frequency, water temperature, and the count of times the water heater has been shut off by the stochastic controller. This interactive platform is designed not only to keep users informed but also to foster an engaging user experience as part of the broader goal of introducing smart grid solutions. Initially, we were uncertain about including temperature measurement in our design due to the complexity it presented. It seemed that accurately capturing temperature data would necessitate a range of additional materials and equipment, like a fully operational water heater connected to a water supply, which could complicate our demonstrations. However, after thoughtful consideration and discussions with both the committee members and UCF faculty, we've decided that we will be able to demonstrate the accurate reading of temperature even without a real water heater. We're exploring ways to integrate this feature without compromising the ease of demonstration, while ensuring it doesn't detract from the overall functionality and value of our design.

In the project's final design, it is requested that we implement the stochastic controller as a local controller that does not require communication infrastructure. Ideally, it will operate without any dead band while achieving reliable performance with internal water heater controls. However, for sake of simplicity and testing, we will first develop a design in which the ON/OFF operations of the controller do operate within a frequency dead band, and once this design is tested and proven to work, we will implement the stochastic demand-side management (S-DSM) controller that does not rely on a dead band, which will ultimately provide better and more accurate results.

7 Software Design

7.1 Software Flowchart

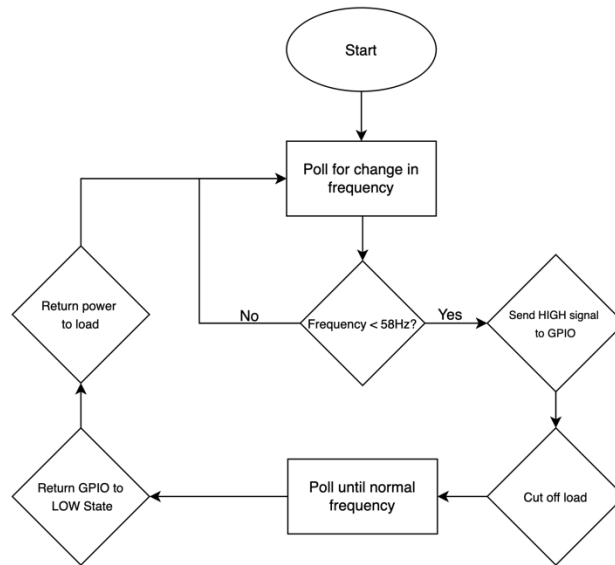

Figure 23: Software Flowchart

The system utilizes a continuous polling mechanism to monitor the frequency of the incoming power supply. When the microcontroller detects a frequency dip below the threshold of 58 Hz, it immediately asserts a high signal on a designated GPIO pin. This high signal serves as an indicator of the abnormal frequency condition and persists until the system frequency returns to its normal operating range. Once the frequency stabilizes within the acceptable limits, the microcontroller changes the GPIO signal, switching it to a low state. This approach ensures that the system can quickly respond to frequency deviations and provide a reliable means of signaling the current power supply status to other connected components or subsystems.

While this method provides a reliable means of detecting and signaling frequency deviations, future iterations of the product could benefit from adapting a stochastic algorithm. This algorithmic enhancement would enable more sophisticated decision-making and control strategies that would aid the grid much more than this system currently does.

To validate the effectiveness of the stochastic algorithm, Hardware-in-the-Loop (HIL) testing could be employed. HIL testing allows for the integration of the physical system with a simulated environment, enabling comprehensive validation of the algorithm's performance under various scenarios. However, due to the complexity of setting up the HIL communication infrastructure and the associated testing environment, this approach was not implemented in the current design.

Nevertheless, the nature of the system architecture allows for possible future integration of HIL testing, providing a pathway for accurate validation and refinement of the stochastic algorithm. By leveraging HIL testing in future iterations, the product can be thoroughly evaluated and optimized, ensuring reliability in real-world applications.

7.2 Stochastic Controller Implementation

The design of the stochastic controller for is centered around the efficient and intelligent operation of household water heaters in response to grid frequency deviations. Utilizing the Texas Instruments MSP430 microcontroller, this design leverages its low-power consumption and high integration capability to perform real-time monitoring and control, to reliably maintain grid stability.

In the implementation of the stochastic algorithm, the MSP430 serves as the decision-making unit, evaluating the grid's frequency against a predetermined nominal value of 60Hz. Upon detection of a frequency that falls below the threshold, indicative of an under-frequency event, the controller is programmed to reduce the electrical load by deactivating a certain percentage of the connected water heaters. Conversely, an over-frequency event triggers the controller to increase the load by activating additional water heaters. This control logic is executed periodically, in accordance with a time step Δt , ensuring that the system reacts promptly to frequency fluctuations, as discussed earlier.

Algorithm 1: S-DSM Controller Aggregated Performance

```
1 for Every  $\Delta t$  seconds do
  Input:  $f_t, r_t$ 
  Output:  $r_{t+1}$ 
2  if  $f_t < f_0$  then
3    Under-frequency mode triggered:
4    • Reduce load by turning off an  $\alpha$  portion of
5      water heaters in ON mode.
6    • Update:  $r_{t+1} = (1 - \alpha)r_t$ 
7  end
8  if  $f_t > f_0$  then
9    Over-frequency mode triggered:
10   • Increase load by turning on an  $\alpha$  portion of
11     water heaters in OFF mode.
12   • Update:  $r_{t+1} = r_t + (1 - r_t)\alpha$ 
13 end
14 if  $f_t = f_0$  then
15   Neither mode is triggered:
16   • Maintain current operation status.
17   • Update:  $r_{t+1} = r_t$ 
18 end
19 end
```

Figure 24: Stochastic Algorithm

We will be programming the MSP430 using Code Composer Studio (CCS) as our integrated development environment (IDE) to write, debug, and flash the firmware onto the microcontroller. Within CCS, we can utilize C or assembly language to create efficient code that interacts directly with the microcontroller's hardware peripherals, such as timers for the Δt interval and GPIO for relay control. The code structure encapsulates the essential elements of the stochastic algorithm, including the frequency measurement, decision-making logic, and the execution of control actions.

Ensuring the reliability of our design requires comprehensive testing of the stochastic controller. This involves simulating various grid conditions and observing the controller's response to ensure it aligns with the expected behavior. The test results not only validate the functionality of the controller but also provide insights into potential areas for optimization, leading to iterative improvements in the system's design. We started the implementation of our design code without using a stochastic controller, where we simply inputted a HIGH signal to one of the GPIO pins that output 3.3v, which was connected to a solid-state relay that activates with any voltage over 3V. This output would simulate the frequency falling

below a predetermined dead band. However, in the stochastic controller algorithm, these signals would not rely on a dead band and would instead rely on the dynamic α value that changes according to how much the current frequency has deviated from the nominal value.

7.3 Polling

For our project, the need to acquire analog data from external sensors is extremely important which led us to interface our MSP430 microcontroller with an Analog-to-Digital Converter (ADC) through SPI (Serial Peripheral Interface) communication. This involves polling, where the MSP430 continually checks the status of the ADC to retrieve the converted analog data.

To begin this process, the MSP430 must initialize the GPIO pins needed, timers, and any other relevant settings to establish a foundation for the upcoming operations. The SPI communication module is then configured to establish a link between the MSP430 and the ADC. In this configuration, the SPI protocol facilitates bidirectional communication, allowing the MSP430 to send commands and receive converted analog data from the ADC.

The core of our interfacing strategy lies within a dedicated polling loop embedded in the main program. This loop consistently monitors the status of the external ADC, prompts the ADC to begin its conversion process using SPI, and subsequently reads the converted analog data when it becomes available. The polling loop ensures data integrity by continuously checking the ADC status through specific registers or flags to confirm the completion of the conversion process.

Upon confirmation, the MSP430 reads the ADC value through the established SPI communication link and processes the acquired data which the GSFD (Grid Stabilizing Frequency Detector) will then act upon. This chosen polling-based approach with SPI communication provides a robust and straightforward method for real-time analog data acquisition which will be crucial for our system.

7.4 Use Case Diagram

A use case diagram is a visual representation used in system and software engineering to depict the interactions between a system and its external entities, known as actors. These actors can be users, other systems, or hardware components. In our design, the use case diagram illustrates the system's functionalities and how the actors – which are the user and the grid – interact with it.

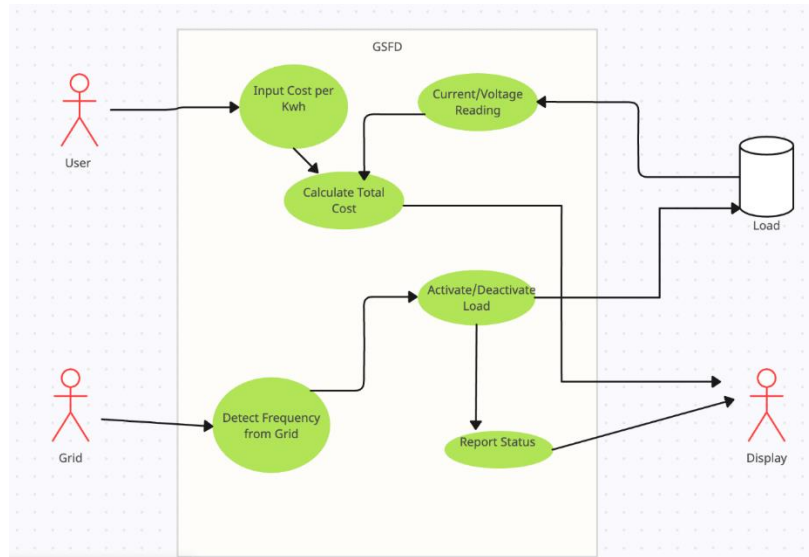

Figure 25: Use Case Diagram

In our diagram, there are two main actors: the user and the grid. The user interacts with the GSF D by providing input, such as the cost per kilowatt-hour, which the system uses to calculate the total cost of electricity consumption. The system also monitors the current and voltage to assess the power usage, which contributes to this calculation. Another key interaction is with the grid, where the GSF D detects the grid's frequency. This detection enables the system to activate or deactivate the connected load (such as a water heater) in response to fluctuations in the grid's frequency. This functionality is part of the system's aim to help stabilize the grid by intelligently managing the load. Finally, the system communicates with the user by reporting the status, which keeps the user informed about whether the load is active and provides insights into the associated costs. This use case diagram serves as an essential tool for understanding the scope of the GSF D system and clarifying its operations for both the designers and the stakeholders involved in the project.

7.5 User Interface

Our user interface will serve mainly to display information. However, the user will be able to interact with the screen through touch as it is a capacitive touch screen. The goal is to make our display aesthetically pleasing and for the information to be displayed in a way that is uniform and easy to understand.

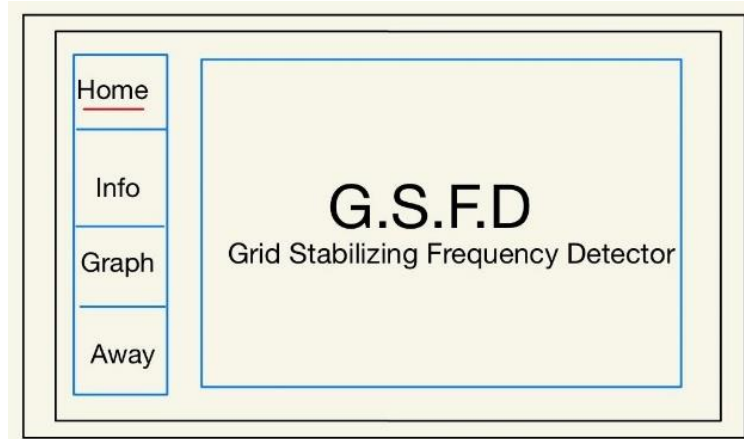

Figure 26: User Interface Home Screen

Upon startup, the 'Home' screen will be displayed and will serve as a landing page for the user. The name of our project, GSFD (Grid Stabilizing Frequency Detector), will be shown as well as the pages menu to the left as shown in Fig.26. From this page, the user will be able to navigate to any of the other pages they would like to explore.

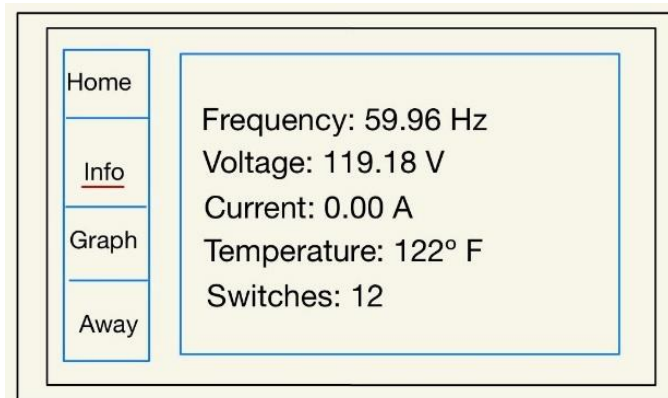

Figure 27: User Interface Info Screen

The 'Info' page will do exactly what its title says... it will display important information that has been obtained by our system such as frequency, voltage, current, temperature, and switches, which means the amount of times the GSFD has switched off the load due to the frequency deviating from the nominal value.

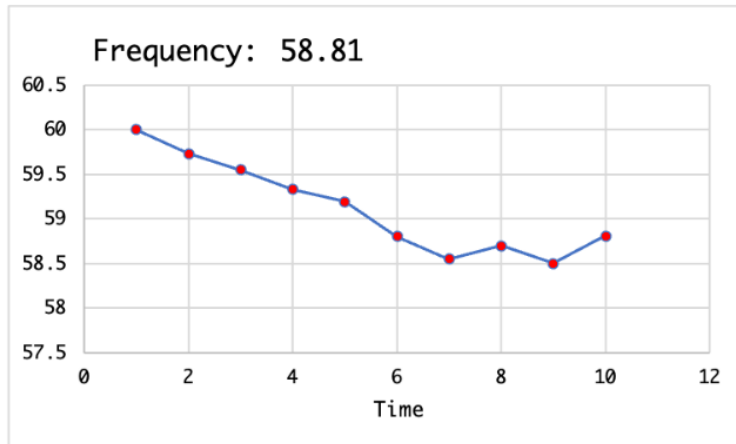

Figure 28: User Interface Graph Screen

Next, the user will be able to navigate over to the 'Graph' page. This page will show a real-time grid frequency and temporal frequency graph as seen in Fig.28. This graph will show the changes in frequency over time as well as the current frequency value at the top of the graph so the user won't have to decipher what exact value the most recent point is plotted to on the y-axis.

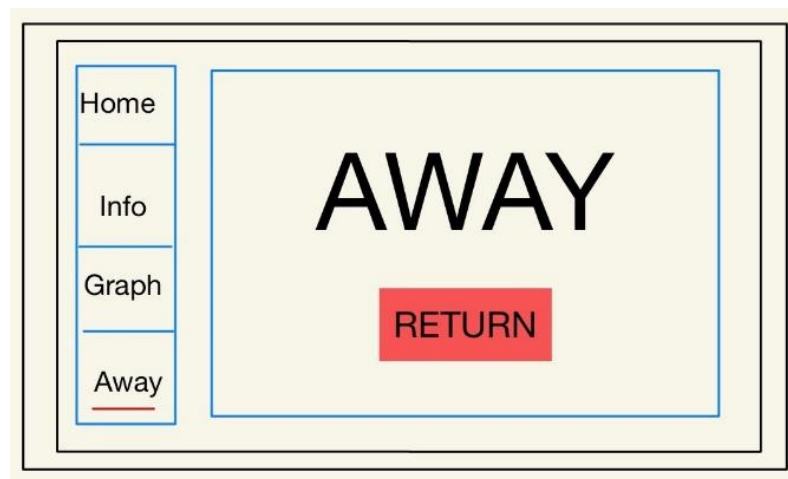

Figure 29: User Interface Away screen

The next page, *Away*, that is seen in Figure 29 will show the word **AWAY** in large font, as well as a button that will say **RETURN**. The purpose of this page is for the user to access it if they want our system to keep their water heater turned off indefinitely. While on this screen, we would want to disable the functions of all other buttons on the screen except for the **RETURN** button. Our reasoning behind the decision to disable every other button is based on the fact that there would be no

need to display any information or interact with buttons if the water heater is off. Once the RETURN button is pressed, all normal functionalities will be resumed and the display will navigate back to the *Home* page.

7.5.1 State Diagram

The user will be able to interact with the screen as it is a touch screen and will be able to navigate through a menu of different pages which will be on the left side of the screen. Whenever the user selects a page they would like to navigate to, that tab will be highlighted. Shown in Fig.30 below, there will essentially be four different pages. The 'Home' page, 'Info' page, 'Graph' page, and finally the 'Away' page.

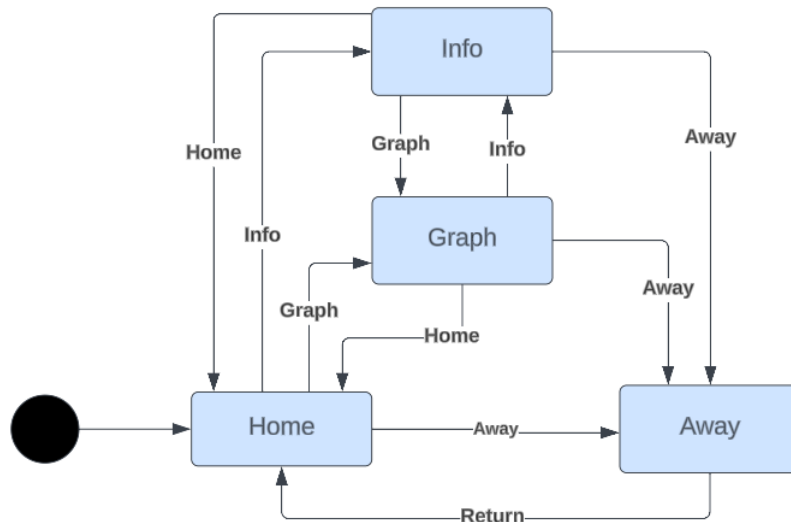

Figure 30: State Diagram

8 PCB Design

8.1 Power Supply PCB Design

Below is the 2D model of the power supply PCB. This board is responsible for converting 12vac to 5vdc while providing a stable output. The LM7805 voltage regulator helps to ensure a stable 5V output to the active components and hardware present in this project. The input stage features a full-wave bridge

rectifier composed of a 1N4001 diodes (D1-D4), which rectifies the incoming AC signal. To smooth out the ripples in the rectified voltage, the design includes two filter capacitors (C4 and C6) placed close to the rectifier and the voltage regulator to minimize electromagnetic interference.

The use of through-hole components allows durability and ease of replacement; longevity and the ability for maintenance are critical for GSFD.

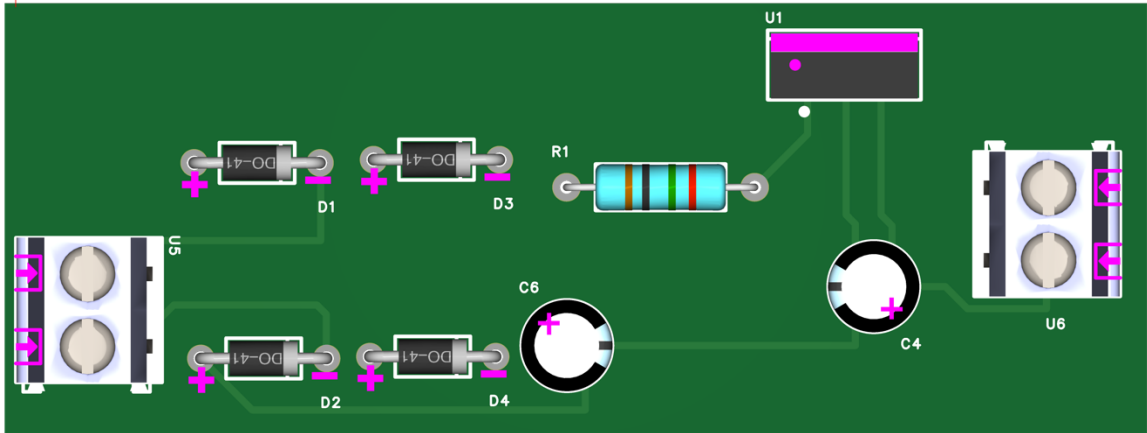

Figure 31: 5VDC PCB

8.2 Analog Circuit and Microcontroller PCB Design

The following PCB houses the MSP430F5529 microprocessor chip and all necessary components and I/O connections. This design was originally made for testing purposes only early in the design process and was intended to be implemented onto a Master PCB for the final product, however, as a fully functional PCB it was acceptable to be used within this project for final demonstration purposes.

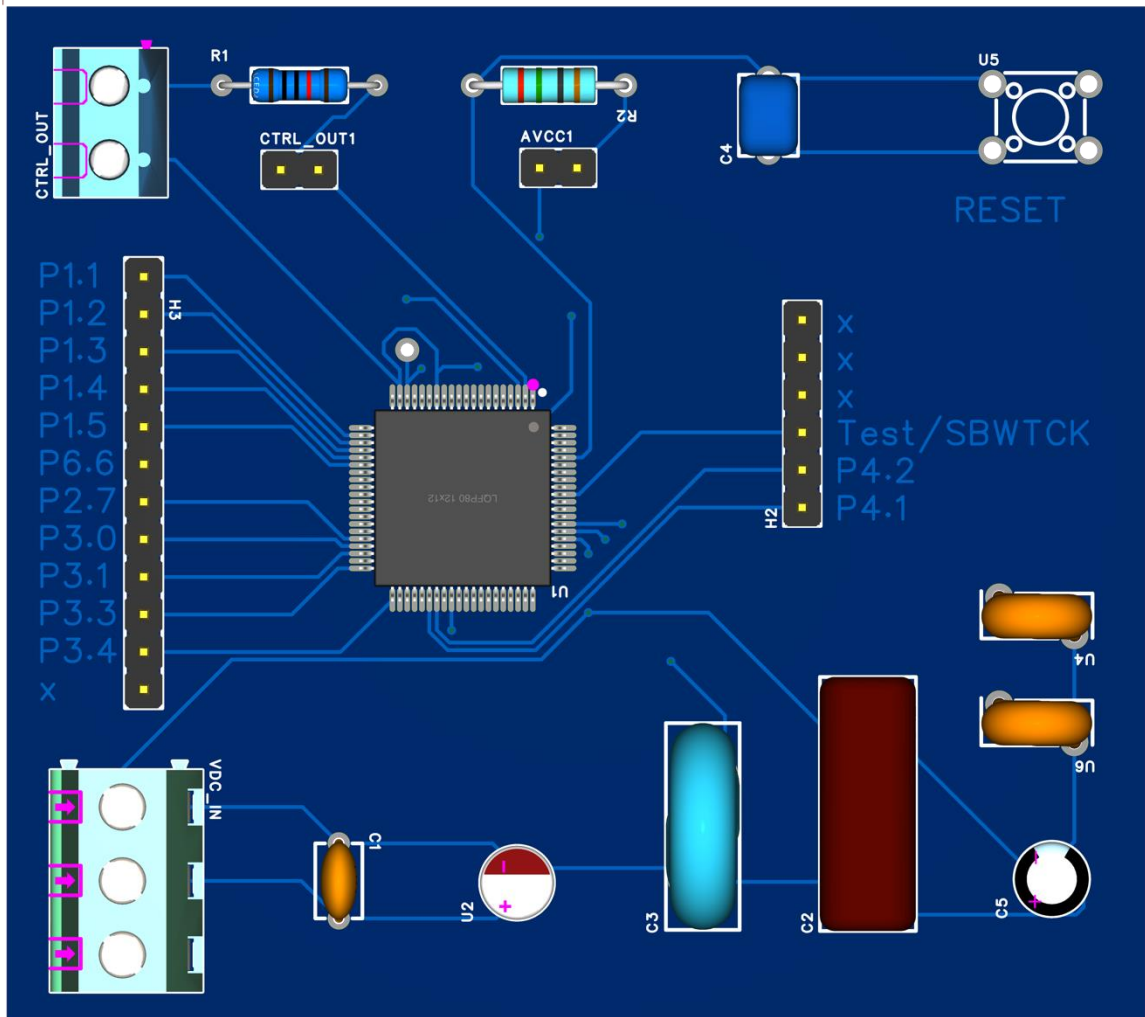

Figure 32: MSP Breakout PCB

The following PCB contains all analog circuits present in our design. Starting from the top is the 12VAC input which is fed to the voltage and frequency measurement circuits. The bottom of the board contains the current measurement circuit, and all three circuits have input disconnects for testing purposes. The right side of this board contains the 5VDC input from the power supply and all output header pins. This PCB was originally intended to be combined with the above PCB into one Master PCB, however, the final pcb was not completed and tested in time for the final product, so these testing pcs were used instead.

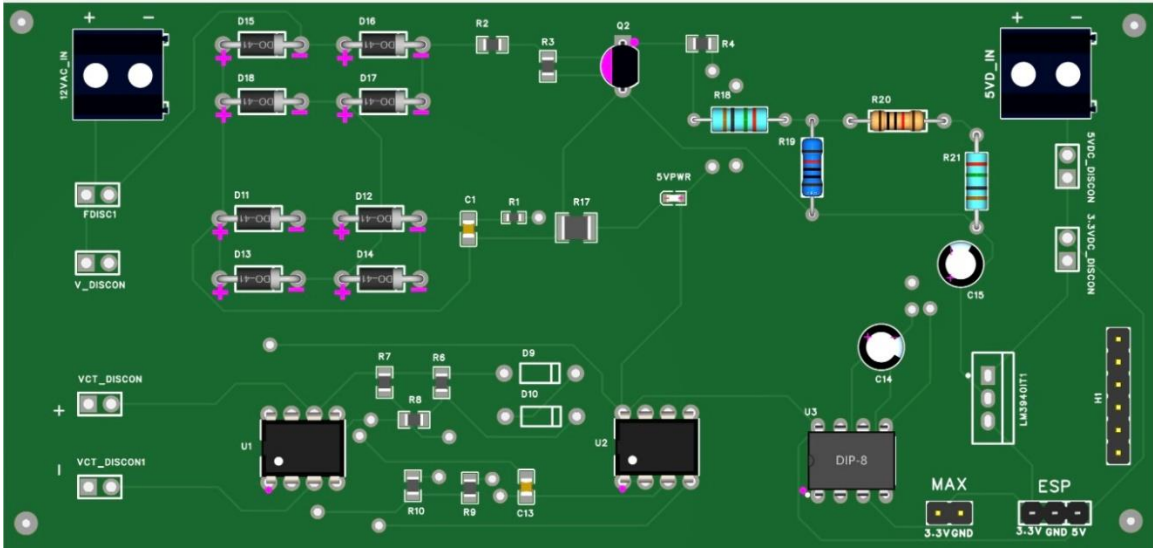

Figure 33: Analog Circuits PCB

9 System Testing

9.1 Hardware Testing

9.1.1 Power Supply Circuit

To begin system testing we started with the power supply circuit, but before interacting with the 120V AC to 12V AC transformer, we first wanted to work with some simulations to ensure the desired output was achievable with our chosen component values. Using Multisim Pro Simulation software, we recreated the circuit and ran some test and observed our anticipated output voltage of 5V DC. Building the power supply circuit on a breadboard using the LM7805, we originally did not get the predicted output response. After some evaluation, we realized that between the signal generator we were using and the half-wave rectifier design, the input voltage to the LM7805 was insignificant to turn on the regulator. By redesigning with a full-wave rectifier and using a higher amplitude signal, we were able to complete our power supply circuit which consistently outputs between 4.99 and 5.01 VDC.

9.1.2 Voltage Measurement

Next, we tested our design for the voltage measurement circuit. Utilizing the function generator and inputting a 60 Hz, 7Vrms voltage signal, we measured the waveform on the oscilloscope both directly after the bridge as well as at the output. The voltage drops across the diodes was as anticipated at approximately 1.4V, so the bridge system seemed to be functioning correctly. The output voltage waveform was slightly off from the simulated output by approximately 0.2V. This

was attributed to the fact that we did not have the exact resistor values as was in our design. For the 390k Ohm resistor, we utilized what we had on hand which was a 300k Ohm in series with a 62k Ohm, totaling 392k Ohms for R1, and a 130k Ohm load resistor to represent the input impedance of the ADC to create the voltage divider. This in conjunction with a 100uF capacitor completed the circuit. Given the stacked resistance tolerances and the slightly different overall resistance value for R1, this discrepancy seemed logical, and the overall design for the voltage measurement was considered adequate for an initial design.

9.1.3 Current Measurement

After simulating the current measurement circuit in Multisim, we began testing on the breadboard with the LM351 op-amp. Using a 1:1 resistor ratio for the feedback loop using two 1k Ohm resistors, we started assembling the circuit. We included a general-purpose diode in the feedback loop as well as at the output of the op-amp and provided a +/- 5V DC signal to the Vcc+ and Vcc- terminals on the op-amp. The output of our current transformer was a sinusoidal voltage waveform with a max amplitude of 3V at 60 Hz, but since we didn't have the current transformer in hand at time of testing, we used a function generator to simulate the signal that would be coming in from the transformer. Again, including a 130k load resistor at the output to simulate the input impedance of the ADC, we simulated the circuit and observed the output results on the oscilloscope. At 3V AC at the input, the output was a half-wave rectified waveform with an amplitude of 2.99V, equal to the amplitude of the input. This was important as the input voltage would be ranging anywhere from 0 to 3V AC determined by the current through the transformer going from 0 to 30A max. When the voltage signal was low, we wanted to make sure it would be enough for the ADC to work with.

9.1.4 Temperature Measurement

During initial testing we planned to implement an ambient temperature sensor that accurately detected the temperature of the air around it. After further research we determined that this type of temperature sensor would not be able to accurately measure the temperature of the water inside the water heater due to the thick insulation in the water heaters casing. The only way to accurately get an estimate of the temperature inside the water heater without tapping into the internal thermostat is by putting a temperature sensor up against the hot water line that is leaving the water heater upon use. The exiting hot water line on the water heater is not heavily insulated, which allows for a more direct and precise measurement of the water temperature.

9.1.5 Frequency Measurement

After simulating the frequency measurement circuit in Multisim, we started to piece it together on the breadboard for hardware testing. Starting with a standard full-

wave bridge rectifier, we then connected the output to a 1:1 voltage divider circuit with two 10k Ohm resistors to limit the current going into the base of the transistor. After providing the transistor with a 5V DC input through a 75k Ohm resistor, which was only 1 Ohm less than in our simulation, we again incorporated an 130k Ohm load resistor to simulate the input impedance of the ADC. With the oscilloscope we measured the frequency and amplitude of the output waveform to find a 3.03V peak at 60 Hz. This satisfies the 3.3V maximum input restriction of the onboard ADC.

9.1.6 SSR Functionality

To test the functionality of the SSR, we conducted a targeted test to verify the operation of the relay within our circuit design. The test configuration was as follows: we used a function generator to emulate the electrical load of a water heater, set to output a standard 60Hz sine wave. This function generator served as a controlled environment to test the SSR's response to voltage variations.

The SSR was situated between the simulated load and the MSP430 microcontroller. Its primary function was to disconnect the load if the input voltage surpassed a 3V threshold, thus simulating a response to a dip in the grid frequency. To test this, the MSP430 was programmed to deliver a 3.3V signal on one of the GPIO pin, which would be activated by the manual pressing of a switch. The action of pressing the switch was an analog for the grid frequency falling below the nominal 60Hz, prompting the SSR to cut power to the load. This test affirmed the SSR's role in our GSFD system, ensuring that it correctly executes the interruption of power under specified conditions, which is vital for the stabilization of the grid in practical applications.

10 Administrative Content

10.1 Budget Estimates

Equipment	Link	Cost
MSP430F5229	https://www.ti.com/tool/MSP-EXP430F5529LP#order-start-development	\$12.99
12V/10W AC/AC Power Transformer	https://www.amazon.com/dp/B0BPM4SD2P?ref=ppx_yo2ov_dt_b_product_details&th=1	\$15.88
Crydom D2450-B SSR	https://www.mouser.com/ProductDetail/558-D2450-B	\$75.04

Twiddec/Output Single Phase SSR Solid State Relay 25A 3-32V	https://www.amazon.com/dp/B07P8DMZD6?ref=ppx_yo2ov_dt_b_product_details&th=1	\$11.99
SCT013000 Split Core Current Transformer	https://www.amazon.com/dp/B09MRVTQ8B?psc=1&ref=ppx_yo2ov_dt_b_product_details	\$15.99
Amgis CT1030 Solid Core Current Transformer	https://www.digikey.com/en/products/detail/amgis-llc/CT-1030/2362757	\$6.24
AM2301B - Wired Enclosed AHT20	https://www.adafruit.com/product/5181	\$7.95
Adafruit PT100 RTD Temperature Sensor Amplifier - MAX31865	https://www.adafruit.com/product/3328?gad_source=1&gclid=Cj0KCQjwlZixBhCoARIsAIC745AC569K0viFpR6R0CwrvLFrCDfWyliZLkM1A801dcrXXygbIf_nEnkaAnxSEALw_wcB	\$14.95
Platinum RTD Sensor - PT100	https://www.adafruit.com/product/3290?gad_source=1&gclid=Cj0KCQjwlZixBhCoARIsAIC745Dz3NOCXEMLmDofJGeLIXoL_I_o616Xm8SX3SiAqa67ajbhitK06c0aAkQdEALw_wcB	\$11.95
EvoSensor RTD Pt100	https://evosensors.com/collections/pt100-2-wire-class-b/products/2-wire-rtd-pt100-temperature-sensor-with-adhesive-surface-patch-and-10ft-of-lead-wire	\$95
MSP-EXP430F5529LP * 5	https://www.digikey.com/en/products/detail/texas-instruments/MSP-EXP430F5529LP/4311683	\$77.95
ESP-WROOM-32 * 4	https://www.amazon.com/gp/product/B0718T232Z/ref=ox_sc_act_title_1?smid=A30QSGOJR8LMXA&psc=1	\$40.00
GSL1680F	https://www.buydisplay.com/tft-5-inch-lcd-display-module-controller-board-serial-i2c-ra8875	\$80.61
3.5 Inches TFT LCD Touch Screen Shield Display Module 480x320	https://www.amazon.com/dp/B0BWJHK4M6?ref=ppx_pop_mob_ap_share&th=1	\$16.99
PCB Design	https://jlcpcb.com/	\$496.26
Total	N/A	\$

Table 21: Budget and Financing

10.2 Bill of Materials

#	Description	Model	Quant.	Cost
1	Kzfuli VAC Transformer	1210KY	1	15.88
2	Crydom SSR	D2450-B	1	75.04
4	Adafruit RTD Pt100	RTD Pt100	1	11.95
5	PCB	N/A	3	24.05
6	LCD	3.5 Inches TFT LCD Touch Screen Shield Display Module 480x320	1	16.99
7	MSP	MSP430F5529	1	12.99
8	ESP32	ESP32 WROOM Dev Board	1	9.99
9	Adafruit MAX31865	MAX31865	1	14.95
10	Amgis CT	CT1030	1	6.24

Table 22: Bill of Materials

10.3 Milestones

Task	Duration	Status
Senior Design 1 and Documentation	Fall 2023	Complete
Brainstorming	Week 1 (August 21 st) – Week 2 (August 28 th)	Complete
Project Selection	Week 3 (September 4 th)	Complete

Initial Document – Divide and Conquer 10 Page Document	Week 4 (September 15 th due date)	Complete
Research Component List	Week 6 (September 25 th)	Complete
Schematic Capture	Week 6 (September 25 th)	Complete
Bill of Materials	Week 7 (October 2 nd)	Complete
Table of Contents	Week 8 (October 9 th)	Complete
45 Page Document	Week 9 (October 16 th)	Complete
60 Page Document	Week 11 (November 3 rd due date)	Complete
120 Page Final Document	Week 16 (December 5 th due date)	Complete
Senior Design 2	Spring 2023	Ongoing
Order Parts and PCB	Week 4	Complete
PCB Assembly	Week 6	Complete
Testing and Redesign	Week 6	Complete
PCB Assembly	Week 12	Complete
Testing	Week 13	Complete
Final Presentation	Week 14	Complete

Table 23: Milestones

10.4 Work Distribution

Member	Contribution
Briggs Green	PCB Design Temperature Sensor Calibration Hardware Testing
Alex Cruz	User Interface LCD Software Flow Microcontrollers ADC Hardware Testing
Aymes Glidewell	Stochastic Implementation Embedded Programming Temperature Measurement Coding PCB Design Circuit Protection Hardware Testing
Eric M. Doolin	Analog Circuit Design Power Supply Switching Mechanism Temperature Sensor Hardware PCB Design Hardware Testing

Table 24: Work Distribution

11 Conclusion

In conclusion, the development of the GSFD signifies a considerable achievement for our team, particularly given our initial limited exposure to grid stabilization technology. This endeavor required us to research the dynamics of grid stress, the implications of load management, and the complex workings of stochastic control systems. The integration of these components highlights our dedication to advancing sustainable energy solutions. Through a concerted group effort, we completed the bulk of design for a device with the potential to make a meaningful impact on energy consumption and grid stability.

We began our project by defining specific subsystems and establishing operational goals to address potential challenges. This planning translated into concrete engineering specifications, which then directly informed our design decisions for the GSFD. These specifications have guided us toward achieving tangible and testable results.

Following the establishment of specifications, we embarked on a thorough examination of each subsystem, which facilitated the conception of designs aligned with our targets. This groundwork was key in selecting components, considering essential factors such as spatial constraints, supplier dependability, system compatibility, and potential for other applications. After preliminary system integration and testing, we have seen that the components we have been able to test have proven to be accurate and will produce accurate results for our design. While further calibration is anticipated, we are confident in the reliability of our chosen hardware as we move forward.

In our design selection process, we carefully reviewed every part of our design process, prioritizing cost-efficiency, accuracy, compactness, and functionality. This careful consideration enabled us to balance budget constraints with performance, ensuring the user-friendliness of the GSFD. It's important to highlight that our GSFD project has progressed smoothly, with many components being readily available and able to be delivered on time. This efficiency has allowed us to focus on optimizing our design and ensuring each part meets our high standards for performance and reliability, preparing us to handle any new tasks to keep our project on track for the next term.

Our GSFD project not only necessitated a deep dive into the technicalities of hardware but also required us to develop software that ensures reliable operation. The software design, featuring a meticulously crafted algorithm for our switching mechanism, is the brains of our design. It allows for precise responses to fluctuating grid frequencies, ensuring that our GSFD can operate autonomously and efficiently. The software algorithm that we are using has been tested through various simulations and real-world scenarios and has been optimized for performance.

Each component selection, from the choice of current transformers to the implementation of ADCs for accurate measurement, was driven by a combination of theoretical knowledge and hands-on experimentation. The detailed comparison and selection process outlined in our report shows our commitment to a design that balances cost, efficiency, and reliability. We also felt it was important to add the development of the housing unit for our GSFD—a topic that bridges the gap between technical design and consumer usability, which highlights the practical considerations that must be balanced in engineering design. This comprehensive approach ensures that our GSFD is not only technically competent but also accessible and practical for end-users.

Before progressing to the advanced stages of our design project, our team engaged in extensive testing with key elements such as the frequency detection module, the control logic for the solid-state relay (SSR), and the communication protocols for system monitoring. While certain aspects of the GSFD are still in development, we have laid out a clear plan for acquiring the necessary hardware, including multiple iterations of our PCB. Given the pressing timeline, we are committed to using the interim period for collaborative design refinement to ensure we stay on track and address any potential challenges promptly. Our next steps include exhaustive testing of the PCBs and ensuring their functionality aligns with our project's requirements.

Ultimately, our goal is to deliver a self-regulating grid frequency detector that we can install on a large scale into many consumers' homes to facilitate the need for demand side frequency regulation, contributing to the stabilization of the power grid. We are confident that the detailed designs and research presented in this report lay a solid foundation for creating a practical solution to the pressing need for intelligent energy management systems. Anticipated to be cost-effective, highly efficient, and straightforward to implement, our GSFD is set to provide a valuable tool for enhancing grid reliability. Our dedication to this initiative is steadfast, and we look forward to dedicating our efforts in the coming semester to bring this innovative system to completion.

References

- [1] SkyCentrics, "SkyCentrics A.O. Smith CTA-2045 EcoPort Communications Package Wi-Fi (Formerly CEA-2045)," SkyCentrics Store. [Online]. Available: <https://store.skycentrics.com/skycentrics-ao-smith-cta-2045-ecoport-communications-package-wi-fi-formerly-cea-2045/> [Accessed: 10/20/2023].
- [2] PNNL, "Grid Friendly™ Water Heater Controller," Pacific Northwest National Laboratory. [Online]. Available: <https://www.pnnl.gov/available-technologies/grid-friendlytm-water-heater-controller> [Accessed: 10/20/2023].
- [3] R. Ruark, "AC Grid Frequency Monitor," 2016. [Online]. Available: http://robruark.com/projects/grid_frequency/ac.html [Accessed: 10/20/2023].
- [4] A. O. Smith Water Products Co., "Commercial Electric Water Heaters," no. 315267-000, 2016. [Online]. Available: <https://s3.amazonaws.com/assets.aosmith.com/damroot/Original/10004/315267-000.pdf>. [Accessed: 10/20/2023].
- [5] Electrical Technology, "How to Wire a 240V AC Outlet for a Water Heater Thermostat (Non-Simultaneous)," Jan. 2020. [Online]. Available: <https://www.electricaltechnology.org/2020/01/wire-240v-water-heater-thermostat-non-simultaneous.html>. [Accessed: 10/20/2023]
- [6] National Instruments, "Title of the Webpage," in _Switch Fundamentals_, [Online]. Available: <https://www.ni.com/docs/en-US/bundle/switch-fundamentals/page/Chunk1073371395.html>. Accessed on: [11/20/2023].
- [7] "Thyristor," in _ScienceDirect Topics_, [Online]. Available: <https://www.sciencedirect.com/topics/engineering/thyristor>. Accessed on: [11/03/23].
- [8] Texas Instruments, "Solid State Relays," Power Management, [Online]. Available: <https://www.ti.com/power-management/power-switches/solid-state-relays/overview.html>. Accessed on: [11/04/23].
- [9] Handyman Calculator, "Voltage Divider - A Comprehensive Guide." [Online]. Available: <https://handyman-calculator.com/voltage-divider-a-comprehensive-guide/>. [Accessed: 11/20/2023].
- [10] Analyse A Meter, "Full Wave Rectifier Circuit Characteristics, Advantages & Disadvantages," Mar. 2016. [Online]. Available: <https://analyseameter.com/2016/03/full-wave-rectifier-circuit-characteristics-advantages-disadvantages.html>. [Accessed: 10/20/2023].

- [11] "Center-Tapped Full-Wave Rectifier," Circuit Globe, [Online]. Available: <https://circuitglobe.com/center-tapped-full-wave-rectifier.html>. Accessed on: [11/03/23].
- [12] "The Essentials of Analog Voltage Comparators and How to Use Them," Digi-Key, [Online]. Available: <https://www.digikey.com/en/articles/the-essentials-of-analog-voltage-comparators-and-how-to-use-them>. Accessed on: [11/03/23].
- [13] "Shunt Resistors," Electrical4U, [Online]. Available: <https://www.electrical4u.com/shunt-resistors/>. Accessed on: [11/03/23].
- [14] "Hall Effect," Electronics Tutorials, [Online]. Available: <https://www.electronics-tutorials.ws/electromagnetism/hall-effect.html>. Accessed on: [11/03/23].
- [15] "Current Transformer," Electronics Tutorials, [Online]. Available: <https://www.electronics-tutorials.ws/transformer/current-transformer.html>. Accessed on: [11/03/23].
- [16] "Split Core vs Solid Core and Why You Should Care," Packet Power, [Online]. Available: <https://www.packetpower.com/blog/split-core-solid-core-and-why-you-should-care>. Accessed on: [11/03/23].
- [17] "AC Series Datasheet," Talema, [Online]. Available: <https://talema.com/wp-content/uploads/datasheets/AC.pdf>. Accessed on: [11/04/23].
- [18] "CT1030 Datasheet," Amgis Toroids, [Online]. Available: <https://amgistoroids.com/wp-content/uploads/2020/03/CT1030.pdf>. Accessed on: [11/03/23].
- [19] "SCT-013-030 Datasheet," Seedstudio, [Online]. Available: <https://statics3.seedstudio.com/assets/file/bazaar/product/101990028-SCT-013-030-Datasheet.pdf>. Accessed on: [11/10/23].
- [20] "C-CT Series Datasheet," Nidec Components, [Online]. Available: <https://www.nidec-components.com/e/catalog/current-sensor/c-ct.pdf>. Accessed on: [11/23/23].
- [21] "Schmitt Trigger," HowToMechatronics, [Online]. Available: <https://howtomechatronics.com/how-it-works/electrical-engineering/schmitt-trigger/>. Accessed on: [11/03/23].
- [22] "Peak Detection Circuits" Elliott Sound Products, [Online]. Available: <https://sound-au.com/appnotes/an014.html>. Accessed on: [11/5/23].
- [23] Texas Instruments, "Zero Crossing Detection Using Comparator Circuit" [Online]. Available: <https://www.ti.com/lit/an/snoa999/snoa999.pdf?ts=1701688567565> Accessed on: [11/03/23]

- [24] M. Pauluk, P. Piątek, and J. Baranowski, "Efficient Zero-Value-Cross Detection for Single-Phase Mains-Powered Motors: A Comparative Study," *Energies*, vol. 16, no. 17, p. 6298, Aug. 2023, doi: 10.3390/en16176298. Available: <http://dx.doi.org/10.3390/en16176298>
- [25] "Zero Cross Detector Circuit Using Transistor," How2Electronics, [Online]. Available: <https://how2electronics.com/zero-cross-detector-circuit-using-transistor/>. Accessed on: [11/03/23].
- [26] "Thermocouple Hub," Omega Engineering, [Online]. Available: <https://www.omega.com/en-us/resources/thermocouple-hub>. Accessed on: [11/03/23].
- [27] Omega Engineering. "How Infrared Thermometers Work." Omega Engineering. [Online]. Available: <https://www.omega.com/en-us/resources/infrared-thermometer-how-work#:~:text=Infrared%20thermometers%20employ%20a%20lens,absorbed%20and%20converts%20into%20heat>. [Accessed: 11/15/23].
- [28] "A Guide to Semiconductor Temperature Sensors" AZoSensors. [Online]. Available: <https://www.azosensors.com/article.aspx?ArticleID=2852>. [Accessed: 11/15/23].
- [29] Analog Devices. "DS18B20 1-Wire® Digital Thermometer." Analog Devices. [Online]. Available: <https://www.analog.com/en/products/ds18b20.html#product-overview>. [Accessed: 11/15/23].
- [30] Adafruit Industries. "DHT22 temperature-humidity sensor + extras." Adafruit Industries. [Online]. Available: <https://www.adafruit.com/product/385>. [Accessed: 11/15/23].
- [31] Texas Instruments. "TMP175-Q1 Low-Power, 2.7-V, Digital Temperature Sensor With I2C/SMBus Interface." Texas Instruments. [Online]. Available: <https://www.ti.com/general/docs/suppproductinfo.tsp?distId=10&gotoUrl=https%3A%2F%2Fwww.ti.com%2Flit%2Fgpn%2Ftmp175> . [Accessed: 11/15/23].
- [32] Analog Devices. "AM2301B - Wired Enclosed AHT20 - Temperature and Humidity Sensor" Analog Devices. [Online]. Available: <https://www.analog.com/en/products/ds18b20.html#product-overview>. [Accessed: 11/15/23].
- [34] "Varistor Working Principle, Types & Metal Oxide Varistor." Electrical4U. [Online]. Available: <https://www.electrical4u.net/electronics/varistor-working-principle-types-metal-oxide-varistor/#:~:text=What%20is%20Varistor%20,the%20resistor%20does>. [Accessed: 11/15/23].

- [34] "How Does a Fuse Work?" ScienceABC. [Online]. Available: <https://www.scienceabc.com/innovation/how-does-a-fuse-work.html>. [Accessed: 11/15/23].
- [35] Grote Industries. "Fuse & Circuit Protection Technical Tips." Grote Industries. [Online]. Available: <https://www.grote.com/technical-tips/fuse-circuit-protection-technical-tips/>. [Accessed: 11/15/23].
- [36] Logic Lineup. "What is TVS Diode?" Logic Lineup. [Online]. Available: <https://logiclineup.com/tvs-diodes/#What is TVS diode>. [Accessed: 11/15/23].
- [37] Mouser Electronics. "Application of Gas Discharge Tubes in Power Circuits." Mouser Electronics. [Online]. Available: https://www.mouser.com/pdfDocs/ApplicationofGasDischargeTubesinPowerCircuits_en.pdf. [Accessed: 11/15/23].
- [38] Analog Devices. "Introduction to SPI Interface." Analog Dialogue. [Online]. Available: <https://www.analog.com/en/analog-dialogue/articles/introduction-to-spi-interface.html>. [Accessed: 11/15/23].
- [39] Circuit Basics. "Basics of the I2C Communication Protocol." Circuit Basics. [Online]. Available: <https://www.circuitbasics.com/basics-of-the-i2c-communication-protocol/>. [Accessed: 11/15/23].
- [40] Circuit Basics. "Basics of UART Communication." Circuit Basics. [Online]. Available: <https://www.circuitbasics.com/basics-uart-communication/>. [Accessed: 11/15/23].
- [41] Electronics Tutorials. "Analog to Digital Converter (ADC)." Electronics Tutorials. [Online]. Available: <https://www.electronicstutorials.ws/combination/analog-to-digital-converter.html>. [Accessed: 11/15/23].
- [42] Arrow Electronics. "Analog to Digital (ADC) Converter: Types and Basic Functions." Arrow Electronics. [Online]. Available: <https://www.arrow.com/en/research-and-events/articles/analog-to-digital-adc-converter-types-and-basic-functions>. [Accessed: 11/15/23].
- [43] Electronic Design. "Understanding Delta-Sigma Modulators." Electronic Design. [Online]. Available: <https://www.electronicdesign.com/technologies/analog/article/21798185/understanding-deltasigma-modulators>. [Accessed: 11/15/23].
- [44] D. Bhattacharyya and B. R. Saltzberg, "Time domain analysis of sigma delta modulation" in IEEE Transactions on Communications, vol. 36, no. 8, pp. 941-949, Aug. 1988, doi: 10.1109/26.115820. [Accessed: 11/15/23]

[45] Texas Instruments. "ADS1158 16-Bit, 16-kSPS, 8-Ch Delta-Sigma ADC with PGA Data Sheet." [Online]. Available: https://www.ti.com/lit/ds/symlink/ads1158.pdf?ts=1701347521990&ref_url=https%253A%252F%252Fwww.ti.com%252Fproduct%252FADS1158. [Accessed: 11/15/23].

[46] Texas Instruments. "ADS131A04 24-Bit, 128-kSPS, 4-Ch, Low-Power, Delta-Sigma ADC Data Sheet." Texas Instruments. [Online]. Available: <https://www.ti.com/product/ADS131A04> . [Accessed: 11/15/23].

[47] Texas Instruments. "ADS131E08 24-Bit, 32-kSPS, 8-Ch, Delta-Sigma ADC Data Sheet." [Online]. Available: https://www.ti.com/lit/ds/symlink/ads131e08.pdf?ts=1701282932982&ref_url=http%253A%252F%252Fwww.ti.com%252Fproduct%252FADS131E08. [Accessed: 11/15/23].

[48] Texas Instruments. "ADS1258 - 24-Bit, 30kSPS, 8-Ch, Delta-Sigma ADC with PGA Data Sheet." Texas Instruments. [Online]. Available: <https://www.ti.com/product/ADS1258>. [Accessed: 11/15/23].

[49] Texas Instruments. "MSP430F6768 Mixed-Signal Microcontroller." Texas Instruments. [Online]. Available: <https://www.ti.com/product/MSP430F6768#:~:text=,parameters%2C%20ordering%20and%20quality%20information>. [Accessed: 11/15/23].

[50] Texas Instruments. "MSP430F6769 Mixed-Signal Microcontroller." Texas Instruments. [Online]. Available: <https://www.ti.com/product/MSP430F6769#:~:text=,parameters%2C%20ordering%20and%20quality%20information>. [Accessed: 11/15/23].

[51] Texas Instruments. "MSP430FR6989 Mixed-Signal Microcontroller." Texas Instruments. [Online]. Available: <https://www.ti.com/product/MSP430FR6989#:~:text=,parameters%2C%20ordering%20and%20quality%20information>. [Accessed: 11/15/23].

[52] Texas Instruments. "MSP430F5529 Mixed-Signal Microcontroller." Texas Instruments. [Online]. Available: <https://www.ti.com/product/MSP430F5529#:~:text=,parameters%2C%20ordering%20and%20quality%20information>. [Accessed: 11/15/23].

[53] FocusLCDs. "The Pros and Cons of Using a Segmented LCD." FocusLCDs. [Online]. Available: <https://focuslcds.com/journals/the-pros-and-cons-of-using-a-segmented-lcd/>. [Accessed: 11/15/23].

[54] Admetro. "Resistive vs. Capacitive Touchscreens: Know How These Two Popular Touch Solutions Differ." Admetro. [Online]. Available: <https://admetro.com/news/resistive-capacitive-touchscreens-know-how-these-two-popular-touch-solutions->

differ/#:~:text=Applications%20with%20capacitive%20touchscreens%20allow,the%20human%20body%20for%20input. [Accessed: 11/15/23].

[55] Newhaven Display. "Capacitive vs. Resistive Touch." Newhaven Display. [Online]. Available: <https://newhavendisplay.com/blog/capacitive-vs-resistive-touch/>. [Accessed: 11/15/23].

[56] Newhaven Display. "Types of LCD: Liquid Crystal Displays Explained." Newhaven Display. [Online]. Available: <https://newhavendisplay.com/blog/types-of-lcd/>. [Accessed: 11/15/23].

[57] Imperial Society. "Charge-Discharge Curves: How to Get the Most Out of Your Li-Ion Cells." Imperial Society. [Online]. Available: <https://imperialsociety.in/blog/2022/02/15/charge-discharge-curves-how-to-get-the-most-out-of-your-li-ion-cells/>. [Accessed: 11/15/23].

[58] Occupational Safety and Health Administration (OSHA). "Electrical Safety in the Workplace" (PDF). OSHA. [Online]. Available: https://www.osha.gov/sites/default/files/training-library_electrical.pdf. [Accessed: 11/15/23].

[59] International Electrotechnical Commission (IEC). "Electromagnetic Compatibility (EMC)." IEC. [Online]. Available: <https://www.iec.ch/emc>. [Accessed: 11/15/23].

[60] IEEE Xplore. "KBART Title Lists." IEEE Xplore. [Online]. Available: <https://ieeexplore.ieee.org/Xplorehelp/discovery-services/kbart-title-lists>. [Accessed: 11/15/23].

[61] Clever Compliance. "What is EMC Testing?" Clever Compliance Blog. [Online]. Available: <https://blog.clevercompliance.io/electrical-product-compliance/what-is-emc-testing/>. [Accessed: 11/15/23].

Permissions

Email (required)

ay279834@ucf.edu

Message (required)

Greetings Electronics-Tutorials Team,

I am Aymes, an electrical engineering student at the University of Central Florida. We're working on a project about grid stability and found a diagram of a current sensing transformer on your website (<https://www.electronics-tutorials.ws/wp-content/uploads/2013/09/trans53.gif?fit=510%2C264?fit=355,226>) that would be perfect for our research paper.

Could we have your permission to use this diagram? Full credit to Electronics-Tutorials.com will be given.

Submit