

**DEPARTMENT OF  
ELECTRICAL & COMPUTER ENGINEERING**



**UNIVERSITY OF CENTRAL FLORIDA**

**EEL 4914**

**Senior Design I**

**Intellaturbine – Group 9**

# Table of Contents

<b>1</b>	<b>EXECUTIVE SUMMARY.....</b>	<b>1</b>
<b>2</b>	<b>DEFINITIONS.....</b>	<b>2</b>
2.1	MOTIVATION.....	2
2.2	GOALS AND OBJECTIVES .....	2
2.2.1	<i>Wind Power Output.....</i>	3
2.2.2	<i>Wind Sensors .....</i>	3
2.2.3	<i>Voltage/Current Sensors .....</i>	4
2.2.4	<i>Microcontrollers .....</i>	4
2.2.5	<i>Data Logging.....</i>	5
2.2.6	<i>Display.....</i>	5
2.2.7	<i>Rotational Control System.....</i>	6
2.2.8	<i>Servomotor.....</i>	6
2.2.9	<i>Efficiency.....</i>	7
2.2.10	<i>Battery .....</i>	7
2.2.11	<i>Charge Controller.....</i>	7
2.2.12	<i>Inverter .....</i>	7
2.2.13	<i>Maximum Power Point Tracking .....</i>	8
<b>3</b>	<b>REQUIREMENTS .....</b>	<b>8</b>
3.1	INPUT POWER .....	8
3.2	OUTPUT POWER .....	8
3.3	POWER STORAGE.....	8
3.4	MICROCONTROLLER: CHARGE CONTROL .....	9
3.5	MICROCONTROLLER: DATA LOGGING.....	10
3.6	SERVOMOTOR.....	11
3.7	LCD SYSTEM .....	12
3.8	WIND SENSORS.....	13
3.9	BATTERY .....	14
3.10	CHARGE CONTROLLER.....	14
3.11	INVERTER.....	14

<b>4</b>	<b>RESEARCH .....</b>	<b>15</b>
4.1	HARDWARE .....	15
4.1.1	<i>Alternator</i> .....	15
4.1.2	<i>Full-Wave Rectifiers</i> .....	17
4.1.3	<i>Voltage Regulation</i> .....	20
4.1.4	<i>Battery</i> .....	24
4.1.5	<i>Charge Controller</i> .....	29
4.1.6	<i>Maximum Power Point Tracking</i> .....	32
4.1.7	<i>Inverter</i> .....	35
4.1.8	<i>Efficiency</i> .....	36
4.1.9	<i>Microcontrollers</i> .....	37
4.1.9.1	Texas Instruments MSP430 Series .....	38
4.1.9.2	Microchip PIC18 Series .....	38
4.1.9.3	Atmel ATmegaXX8 Series.....	39
4.1.10	<i>Wind Sensors</i> .....	42
4.1.11	<i>Voltage/Current Sensors</i> .....	44
4.1.12	<i>Servomotor versus Stepper Motor</i> .....	46
4.1.12.1	Stepper Motor .....	47
4.1.12.2	Servomotor .....	47
4.1.13	<i>Control Methods</i> .....	48
4.1.14	<i>Compensator</i> .....	51
4.2	Software .....	53
4.2.1	<i>Data Logging</i> .....	53
4.2.2	<i>Display</i> .....	56
4.1.12.1	Routines.....	56
4.1.12.1	Variable Definitions .....	58
<b>5</b>	<b>DESIGN.....</b>	<b>59</b>
5.1	WIND TURBINE .....	59
5.2	BATTERY BANK .....	60
5.3	CHARGE CONTROLLER.....	61
5.3.1	<i>Maximum Power Point Tracking</i> .....	63

5.4	INVERTER.....	64
5.5	WIND SENSORS.....	66
5.6	VOLTAGE/CURRENT SENSORS.....	69
5.7	MICROCONTROLLER POWER SUPPLY.....	72
5.8	LCD DISPLAY.....	74
5.9	ROTATIONAL CONTROL SYSTEM.....	77
5.3.1	<i>Gears</i> .....	80
5.10	DATA LOGGING.....	81
5.10.1	<i>Hardware</i> .....	81
5.10.2	<i>Software</i> .....	84
<b>6</b>	<b>DESIGN SUMMARY.....</b>	<b>87</b>
<b>7</b>	<b>TESTING.....</b>	<b>96</b>
7.1	INTRODUCTION TO TESTING.....	96
7.2	BRIDGE RECTIFIER.....	96
7.3	WIND TURBINE.....	96
7.4	VOLTAGE REGULATORS.....	99
7.4.2	<i>Buck Converter</i> .....	99
7.5	COMPLETE POWER GENERATION SYSTEM.....	99
7.6	SENSORS.....	100
7.7	BATTERY BANK.....	100
7.8	CHARGE CONTROLLER.....	101
7.8.1	<i>Maximum Power Point Tracking</i> .....	102
7.9	INVERTER.....	103
7.10	DATA LOGGING.....	104
7.10.1	<i>Microcontroller</i> .....	104
7.10.2	<i>Software</i> .....	105
7.11	LCD DISPLAY.....	105
7.11.1	<i>Prototype</i> .....	105
7.11.2	<i>Testing</i> .....	106
<b>8</b>	<b>ADMINISTRATIVE.....</b>	<b>108</b>
8.1	PROJECT MILESTONES.....	108

8.2	BUDGET .....	109
8.3	FINAL PLANS.....	109
8.4	PROJECT SUMMARY .....	110
8.5	CONCLUSION .....	111
<b>9</b>	<b>APPENDICES.....</b>	<b>ix</b>
9.1	BIBLIOGRAPHY .....	ix
9.2	IMAGE PERMISSIONS.....	xii

# List of Figures

Figure 1: Main Intellaturbine Block Diagram.....	1
Figure 2: WINDMAX-HY-1000-24 Turbine.....	15
Figure 3: TLG-500 Alternator.....	16
Figure 4: Bridge Rectifier w/ Smoothing Circuit.....	19
Figure 5: Rectifier Output.....	19
Figure 6: Rectifier Output w/ Smoothing Circuit.....	20
Figure 7: Zener Diode Regulator w/ Emitter Follower.....	22
Figure 8: Buck Converter.....	23
Figure 9: Battery Characteristics.....	25
Figure 10: Deep Cycle Battery Charging Stages.....	26
Figure 11: BJT Battery Monitor.....	28
Figure 12: LM3914 Ten LED Battery Monitoring System.....	29
Figure 13: Sample LM317 Battery Charger Circuit.....	31
Figure 14: MPPT Based on Voltage and Current.....	32
Figure 15: 555 Inverter Circuit.....	36
Figure 16: Arduino Data Logging System Block Diagram.....	40
Figure 17: Interface between Arduino and Data Logging Shield.....	41
Figure 18: Anti-Aliasing Filter using two LMC6484 Op-amps.....	45
Figure 19: Current and Voltage Sensing Process.....	46
Figure 20: Pulse Train for Angle Rotation.....	50
Figure 21: Compensator Response for Different Values of $K_p$ .....	52
Figure 22: Compensator Response for Different Values of $K_i$ .....	52
Figure 23: The Data Logging Process.....	55
Figure 24: Sketch of Proposed Turbine Structure.....	60
Figure 25: Battery System Block Diagram.....	61
Figure 26: Battery Monitor for 24 V System.....	61
Figure 27: Charge Controller Block Diagram.....	62
Figure 28: Charge Controller Circuit.....	63
Figure 29: Maximum Power Point Tracking Block Diagram.....	64
Figure 30: 555 Inverter Stage 1: PWM Generator.....	65

Figure 31: Inverter Circuit Stage 2: Sine Wave Generator .....	66
Figure 32: Inverter Block Diagram.....	66
Figure 33: Wind Speed Interfacing Circuit .....	68
Figure 34: Wind Direction Interfacing Circuit .....	68
Figure 35: Voltage Sensing System.....	70
Figure 36: Current Sensing System .....	71
Figure 37: Bode Plot of Second-Order Low-Pass Filter .....	72
Figure 38: LCD Power Supply .....	74
Figure 39: PCB Layout for LCD Display .....	76
Figure 40: Block Diagram of Magnet Servomotor.....	78
Figure 41: Control System w/ Gear .....	80
Figure 42: Motor and Gear Connection .....	81
Figure 43: Connections between Host Board and Data Logger .....	83
Figure 44: Sketch of Main Data Logging Routine .....	85
Figure 45: Data Measurement Subroutine .....	86
Figure 46: Wind Resource Map .....	89
Figure 47: Voltage Output vs. RPM.....	97
Figure 48: Wire Size Chart.....	98
Figure 49: MPPT Test Circuit .....	102
Figure 50: LCD Module Prototype.....	106
Figure 51: Milestone Tentative Schedule .....	108
Figure 52: Main Segments of the Design.....	111

## List of Tables

Table 1: Servomotor Specifications.....	11
Table 2: LCD System Pin-out .....	12
Table 3: Voltage and Current Sensor Desired Specifications .....	14
Table 4: Charge in Single Battery and System.....	27
Table 5: AWG Wire Gauges .....	33
Table 6: Wind Speed Sensor Characteristics .....	42
Table 7: LCD System 4-bit Write Sequence .....	56

Table 8: LCD Command Set ..... 57

Table 9: Display Function Definitions..... 58

Table 10: RPM vs. Watts and Voltage Produced by TLG-500..... 59

Table 11: Signal-to-Measurement Proportionality Table ..... 84

Table 12: Variable List for Data Logging Routine..... 86

Table 13: Wind Speed vs. Various Outputs Produced by the TLG-500..... 88

Table 14: LCD Prototype Parts List ..... 106

Table 15: Itemized Budget ..... 109

# 1 Executive Summary

It is the intent of our senior design team, Intellaturbine to design and construct a power generation system. This system will utilize two wind turbines to generate power and a battery bank to store said power. The main purpose of the system is to use renewable energy (wind) to power the average household getting it off the power grid. The system will be a smart design utilizing maximum power point tracking (MPPT), having user adjustable parameters, data logging capabilities and real time output display.

This document will outline all the requirements and goals for this project. The team will take a systematic approach in designing this project. Firstly, a great deal of research will be done so that the team will have an extensive understanding of wind turbine design and implementation. Next, the design phase will begin; here the project will be broken into different segments, with each team member being assigned multiple segments. The team will start to build and simulate circuits separately before recombining. A plethora of test scenarios and documentation will then be developed covering both real world and ideal situations.

It is the intent that the goals listed in this document be completed over two academic semesters. In the first, research, design and some hardware acquisition will be completed. In the second semester a prototype will be built, tested and documented illustrating all the design requirements lists in this document. All major components in this project will be sponsored by Shaun Dunbar who will retain ownership of these components. Mr. Dunbar will also serve as a mentor and upon completion a working prototype will be presented to him.

The team for this project consists of four Electrical Engineering majors. Their knowledge, as well researching skills will be heavily relied upon to complete this design in a timely manner. Below in Figure 1 is a block diagram outlining the different segments and how they are interfaced for this project.

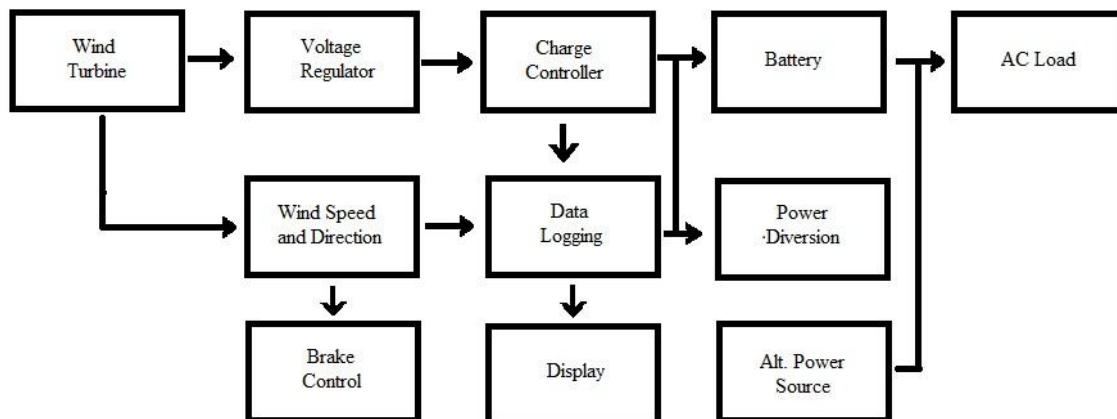

**Figure 1: Main Intellaturbine Block Diagram**

## **2 Definitions**

### **2.1 Motivation**

Intellaturbine is an energy generating and storage device designed to power the average household. It will harness wind energy, convert it and store it for consumption. With continuous increasing oil prices, the search for alternative energy source has also been on the increase. Wind energy is one such alternative as it is renewable; therefore if it can be harnessed efficiently it could be one possible solution to the energy problem. However, there is some hesitation by the average person to install a device such as Intellaturbine because of the perceived cost and technical knowledge required to do so.

Intellaturbine intends to design a turnkey device where some technical knowledge would be required for setup but not enough where it could not be explained in an instruction manual. After initial setup and parameters adjustment, the device should be so low maintenance that little to no interference from the end user will be necessary. There will be an initial investment associated with this device but with virtually no maintenance, coupled with removing the house from the power grid, this investment can be recovered in a short time span. Apart from the obvious visual cues this system should be integrated seamlessly, it should be quiet and autonomous. In fact, apart from the financial saving the homeowner should not even remember that he/she is not connected to the power grid.

The knowledge and experience the team will gain from this project will be priceless. Not only will team members have deep understanding for power generation, wind in particular, they will begin to have an appreciation for renewable energy sources. There are also other aspects of the design, which will broaden their knowledge base. The results of the system will have to be monitored and displayed; this is so that the end user can tell at any given time if the device is performing to specification. Data acquisition is another important aspect of the design; this will enable plots to be developed, which can be analyzed to increase the efficiency of the device. Converters and regulators will have to be developed as the system will go from AC to DC (for charging the batteries) back to AC for consumption.

It is the team's sincerest wish that the work done here will lead to a feasible way to harness renewable energy helping with the energy crisis and doing our part in helping the world to go "green".

### **2.2 Goals and Objectives**

The objective of this project is to design a wind turbine system for individual home use. The intent is to design and implement an intelligent wind turbine system at a low cost where it would be feasible for homeowners. The system once operational should require little to no interaction from the end user. The goals and objectives discuss here will be specifically geared towards achieving the overall main and subsystems.

## 2.2.1 Wind Power Input

A wind turbine will be used to harness energy from the wind, converting it into electrical power. Although cost is always an important factor, for Intellaturbine the “real” power out of the wind turbine will be most important. The goal here is to acquire a lightweight, robust, high output, low maintenance turbine. This design is intended to be a long term; low user interface product that once implemented on the home should give years of service. The turbine will be mounted to the top of a shaft cable of 360-degree rotation for optimal use of the wind direction. An AC signal turbine will be preferred for ease of “transport” of the signal, which will later be rectified to a DC signal.

## 2.2.2 Wind Sensors

An integral part of the Intella-Turbine design is the usage of sensors to monitor and measure a variety of parameters required for proper control of the system. The rotational control system will use two sensors that are critical for the optimal performance of the system. The first sensor that we will be using is a wind direction sensor. The wind direction sensor output will be used as our reference input to the rotational control system. The purpose of the wind direction sensor is to measure the wind direction and feed it to the control system to rotate the turbine blades in the wind direction for maximum power generation. The second sensor used by the rotational control system is the wind speed sensor. The main function of the wind speed sensor is to measure the wind speed and feed it to the microcontroller for monitoring. If the wind speed goes above the maximum threshold speed that the turbine structure can handle then the microcontroller will send out a signal to the rotational control system to rotate the turbine’s blades tangential to the wind direction. This will decrease the efficiency of the wind to spin the turbine blades, and therefore it will slow down the turbine’s RPM.

The means to measure the current wind speed should be provided by an anemometer, or wind speed sensor. Ideally the anemometer should have a high quality rotor to provide reliable wind sensing, and a reed switch that provides one contact closure per rotation to make a pulse. The rate of pulses per second can be converted into an adequate measurement such as miles per hour or meters per second by our microcontroller. As is customary for these types of projects, the cost should be relatively low as well. The most important purpose of our wind speed sensor, however, is to ensure that the turbine does not exceed the maximum safe speed of operation and therefore damage the system.

Typically to measure direction of the wind in a wind turbine, one must measure the deviation between the direction of the blade assembly and the wind direction itself. The sensor may be its own structure, or affixed to the structure already in place to simplify measurements. This sensor will be an important part of the rotational control system that already points the turbine into the wind, and serves as the feedback system for it. To streamline matters, the wind direction sensor will not measure what geographical

direction the wind travels, but will rather output the deviation from the turbine direction into the microprocessor for data logging purposes.

## **2.2.3 Voltage/Current Sensors**

Overall, it is desired that the voltage and current sensing apparatus be integrated with the microcontroller, rather than be their own separate systems. In order for our microprocessor to accept inputs from our sensors – particularly the voltage and current sensors – the analog signal inputs must be filtered and digitized. Ideally the signal must be within acceptable ranges for the rated values of the Analog to Digital converters within our microprocessor to safely handle, and also extensively filtered to reduce noise that may result from the generator, requiring the use of an active filter such as a low pass filter. Additionally, operational amplifiers will be required for the equivalent current signal to reach readable levels within the microprocessor by undergoing some level of gain or amplification. These components should allow for DC voltage and current measurements from our generator to be read into the display and data log, as well as for the current sensor to have adequate gain.

## **2.2.4 Microcontrollers**

The Intella-Turbine project requires the extensive use of microcontrollers to handle the data from all the sensors used in the design, the battery charge controller, LCD, power diversion and the data-logging device. For ease of difficulty we have decided to use more than one microcontroller that will specifically be used for each subsystem of the design. Since the Intella-Turbine will be measuring 8 different variables to display on an LCD display, the microcontroller used for that purpose must have at least 8 analog to digital converter input pins that are internally multiplexed and connected to the analog to digital converter on the chip. Another microcontroller will be used to handle the rotational control system of the design, so it must have multiple output channels that can generate a PWM wave. Since power consumption must be kept at a minimum to increase the efficiency of the Intella-Turbine, the microcontrollers chosen for the display aspect of the design must meet or exceed the following criteria.

- Ultra low power consumption
- Relatively low cost
- JTAG for debugging purposes
- 8 analog to digital converter input pins
- Sufficient number of I/O lines to be used
- Programmable Serial USART
- 16K of Flash memory or more
- Multiple sleep modes to save power when the microcontroller is not being used

Likewise, the microcontroller that we will consider for the data logging aspect of this project must have the following qualities:

- Preferably low cost
- Low power draw
- Moderately fast processor for our needs
- An real-time clock for time stamp / data collecting purposes
- Sufficient memory / EEPROM size
- Sufficient I/O ports to accommodate our data
- A programming language that is C/C++ or similar to C/C++
- A useful software package and IDE
- Development board for testing purposes
- Easy interfacing with an LCD display
- Preferably integrated Analog to Digital Converters
- Support for removable media such as a Mini SD card

## **2.2.5 Data Logging**

To be sure, constructing a functional wind turbine with data logging capabilities is a challenging task indeed, and involves a wide array of technical skills within the Electrical Engineering discipline including not only power electronics, but digital hardware programming and logic as well. The reason we will include a data logging system in our design is to provide a greater understanding by the end user as to where and how the Intellaturbine may be installed for max efficiency. The data, once taken from the device via a portable storage medium and put into a easily readable format for the user, is an important step in analyzing the efficiency of the design, given factors such as battery voltage levels, wind speed and direction, and current in the design. By using and interpreting this data, the user may attempt on his own terms to negotiate a greater level of efficiency or determine whether his immediate area is feasible for wind generation.

## **2.2.6 Display**

The Intella-Turbine design comes with an LCD display to displays various states and parameters of the overall system. Since the design calls for 8 variables to be measured and displayed, the chosen LCD must have at least 8 lines by 20 characters of displaying capability. Since power consumption is to be kept at a minimum, it is desired that the LCD must have low power consumption and low cost. The parameters that will be measured and displayed on the LCD are the wind direction and speed, voltage and

current generated from the turbine generator, battery voltage and present battery charge and the voltage from all three phase of the wind turbine generator.

## **2.2.7 Rotational Control System**

The primary function of the direction control system is to monitor the wind direction for maximum power generation from the wind turbine. The wind sensor will take the wind direction as an input and give an output voltage that's proportional to the wind direction measured by the sensor. That output voltage will be the reference input voltage to the control system. For better versatility and flexibility we have decided to digitally control the system. Digital control systems offers many advantages over analog systems because they are easy to configure and reconfigure through the usage of software and because they are less prone to parameter changes in the system due to environment conditions such as temperature. The input reference voltage will be converted to a digital signal through the analog to digital converter box. That signal will be fed to the digital controller for compensation purposes and then converted back to an analog signal to be used by the motor. The output of the motor will be feedback as a digital signal to the system for stability purposes. As long as the feedback voltage of the system is not equal to the input reference voltage, the control loop will keep on going until the feedback voltage equals the reference input voltage. Once the system reaches that condition it will become stable and the motor shaft will be at the desired angle for maximum power generation from the turbine.

## **2.2.8 Servomotor**

The core of the rotational control system of the Intella-Turbine is a servomotor, which is controlled by the microcontroller on board. The main function to the servomotor is to provide the required torque necessary to rotate the wind turbine around its vertical axis and to hold it in the final position for maximum power generation. The function of the servomotor is to receive a control signal that represents a desired output position of the servo shaft, and apply power to its DC motor until its shaft turns to that position. It uses the position-sensing device to determine the rotational position of the shaft, so it knows which way the motor must turn to move the shaft to the commanded position. The shaft typically does not rotate freely round and round like a DC motor, but rather can only turn 200 degrees or so back and forth.

We chose a servomotor over a stepper motor in our rotational control system because servomotors have high output power relative to the motor size and weight. Since the Intella-turbine is a relatively large and heavy turbine, the use of a stepper motor would be unpractical. Servomotors also provide high efficiency; they can approach up to 90% positional accuracy at relative high loads. Another advantage of servomotors is that they stay cool and only draw current proportional to the load. Since the Intella-turbine is going to be used in a residential home, noise and vibration is of primary concern, that's

why a servomotor is the preferred choice for us because they are audibly quiet at high speeds and are resonance and vibration free.

## **2.2.9 Efficiency**

In the case of a surplus of power and excess voltage supplied to the battery, the system will include an auxiliary load such as a water heater or resistor bank that diverts the power from the main design to prevent overload and thereby a potentially unsafe condition. The charge controller system not only will dictate what constitutes an 'overcharge' condition in the battery, but will act upon this condition accordingly by diverting power to the auxiliary load instead of continuing to charge the battery. This will also serve to reduce the overall heat produced by the main system and allow for safer operation of Intellaturbine.

## **2.2.10 Battery**

The goal for the battery is to monitor voltage using a visual inter face and power small electronic devices. Selection of the battery will be based on these characteristics:

- Durability
- Capacity
- High Cycle Life
- Low Toxicity
- Low Cost
- Low Maintenance
- Low Self-Discharge rate

## **2.2.11 Charge Controller**

The purpose of the charge controller is to safely charge and monitor the battery. The charging system for this project must maintain sufficient voltage and current to charge a 24V battery bank. When the maximum voltage is reached the circuit will switch to the dummy load. If the battery drops too low the controller will switch back to charging the battery. Charge time will also be determined by the charge controller.

## **2.2.12 Inverter**

The inverter from the battery will convert the DC power to a household AC power. Small electronic devices, such as a razor, will be powered by the output from the inverter.

## 2.2.13 Maximum Power Point Tracking

For the most efficient storage of power maximum power point tracking will be used in the circuit design of the charge controller. MPPT is a fairly new design technique and that will closely match the input power to the output power using the DC-DC converter to change the voltage and the current into the battery system.

## 3 Requirements

### 3.1 Input Power

In order to sustain the average house hold, there by removing it from the power grid. The Intellaturbine design must have a method of producing power. The method of choice here is wind power generation.

- Wind turbine should produce a minimum of 1000 watts (2 turbines rated at 500 watts will be used here).
- Wind turbine output should be AC for “transportation” reasons.
- AC output will be converted to DC to charge the batteries.
- If one turbine fails the other should still produce (redundancy).

### 3.2 Output Power

To be able to power the average household the system should be capable of producing 120 VAC. It should also be able to produce DC voltage to run the microcontrollers and display units.

- The system should provide standard 120 VAC, 60 Hz output.
- The system should provide 5 VDC output.
- The system should incorporate circuit protection (fuses and/or circuit breakers) for each power output.
- The system should use an inverter to convert the energy stored in the batteries (DC) to AC.

### 3.3 Power Storage

Intellaturbine should be capable of storing the energy generated by the wind turbines and in turn supply this energy in AC form. The battery that will be required for this design is the lead acid flooded battery. The battery bank will consist of four 6V lead acid flooded

batteries connected in series to create a 24V system. Each battery is rated at 520Ah at a rate of 20Hr.

- The system should display the charge status of the battery.
- The system should be able to supply the average household.
- The system should be able to be fully recharged in a maximum time of 360 minutes.

### **3.4 Microcontroller: Display**

The Intella-Turbine design requires the extensive use of microcontrollers to handle the data from all the sensors used in the system, monitoring of the battery through the charge controller, displaying of essential parameters on an LCD display to inform the user of how the wind turbine is operating and also the rotational control system and data logging. In our design there will be a total of eight sensors used to monitor and measure specific parameters essential for maximum power generation from the wind turbine. Since the sensors will be measuring analog signals the usage of an analog to digital converter is necessary to convert the analog signals to digital, to be used by the microprocessor. This requirement calls for a microcontroller that must have at least eight analog to digital converter inputs to digitalize all the signals.

Since the main objective of the Intella-Turbine is to generate power to a residential home, the power dissipation must be kept at a minimum, that's why the microcontroller chosen must consume very low power. Most microcontrollers only have one analog to digital converter with multiple inputs multiplexed internally to it, that means that the signals being monitored can't be measured simultaneously; instead they have to be measured sequentially. Since there is a total of eight inputs to the analog to digital converter, the microprocessor speed must be very fast to be able to handle all the conversion in a very short period of time with minimal delay between measurements.

Another important characteristic of the microcontroller chosen is that it must have sufficient amount of flash memory available for programming. Since the microcontroller is going to be measuring eight signals, the amount of software needed to properly manipulate and handle the data to be utilized by the Intella-Turbine will be considerably large, that's why the chosen microcontroller must have at least 16Kbytes of flash memory available for programming. Since the design requires a large number of I/O data lines, the microcontroller must have sufficient I/O data lines to be able to handle all the inputs and outputs. The JTAG port is needed for debugging purposes and it's an extremely powerful feature that must be incorporated with the microcontroller for testing the system. The next consideration is the programming language supported by the microcontroller, since in our group there is not a Computer Engineer major it will be preferable to use a simple high level language like C or C++. The final consideration before choosing the microcontroller is the cost and availability of the part, the cost must be kept reasonably low because the overall design cost must be kept under the budget given to us by our sponsor.

## 3.5 Microcontroller: Data Logging

The component that is absolutely essential for our data logging system to correctly function is the microcontroller. Among the other functions dictated by the other components in our design, the microcontroller must collect sensible and readable data from the sensors at regular intervals and output these values to both the LCD display and the portable storage medium inserted by the user. In order to fulfill these various tasks within the constraints of the Intellaturbine, the chip must meet a number of criteria.

First and foremost, the microcontroller chosen for data logging purposes must draw a comparatively low amount of power to operate, in order to improve the overall power generation by the design. In an ideal situation a microcontroller that operates at 1 Watt or less should prove to be sufficient for these purposes. To allow for the assembly or high-level language code to provide instructions for the chip, a certain amount of integrated flash memory is desired. An internal data memory size of 16 KB or greater will give us the freedom to code the functions that better decide how the sensor data is handled and logged, as well as make the memory-intensive process of interfacing with an SD card or USB file system all the easier. The speed of the processor is also an important consideration – the microcontroller must not only cycle through the data from several different sensors, but also interpret them into a readable fashion on the LCD and disk drive with a time stamp. To accomplish this, a processor with a crystal oscillator and an operating clock speed of between 16 to 64 MHz is well within our parameters. Typically, the lower the clock speed, the lower the power draw of the device, but by the same token a high clock speed will improve the data logging performance of the Intellaturbine.

The number of available I/O data lines is indeed a factor as well, by virtue of at least four different sensors (wind speed, wind direction, current, voltage) piping their outputs to the device via the microcontroller's input data lines. In order for the display and external storage device to be integrated, the microcontroller must provide output data lines to accommodate them and an additional one for user input. This makes for a total of at least 8 data I/O lines that are required.

To make for better simplicity of testing and debugging the code on our part, the microcontroller should preferably be part of an existing development board. However, if such a thing is not available the preferred package type would be the Dual In-Line Package for each of the various ICs needed. As an Analog to Digital component is necessary for this system to properly process the analog signals from the sensors, support for this function is important for the microcontroller. Also desired is a method of interfacing the device with the LCD, storage drive, and possibly user input.

To make sense of the operation of the processor ourselves, having a high-level programming language that our group members are familiar with such as C/C++ will make the coding aspect of the design significantly less of a hassle. On the subject of cost: given that only the turbine structure, generator and housing will be provided for us by our sponsor, the cost of the ancillary data logging components must come from our own pockets. As such, the cost of a microcontroller and development board together should be around \$60-\$100, or even \$20 or less in a best-case scenario.

### 3.6 Servomotor

A servomotor is a DC motor specifically designed to be used in a closed-loop control system. Since the servomotor will be controlled by a microcontroller using a PWM wave generator with limited voltage and current drive capability, a power amplifier will be used to meet the servomotor's current and voltage requirement. If the armature inductance of the servomotor is too large, the transfer function of the motor will be a third order system, increasing the complexity of the system design, that's why it is desired that the servomotor has a negligible armature inductance so that when designing the rotational control system for the Intella-Turbine the transfer function of the servomotor will be a second order system, reducing the complexity of the design. The servomotor chosen comes with an optical incremental encoder. As the name implies the optical encoder uses LED light sources, emitting photons of light through a series of transparent windows that are detected by photo diodes at the other end. A pulse of voltage is generated each time a transparent window passes the light source. An electronic circuit must be used to count the number of pulses in order to determine the angle of rotation of the motor's shaft. Table 1 outlines the desired specifications for the servomotor.

Rated Output	100	Watts
Max Speed	5000	RPM
Continuous Stall Torque	3.124	lb-in
Peak stall Torque	9.116	lb-in
Peak Current	10.1	A
Torque Constant	1.168	lb-in/A
Voltage Constant	13.8	V/kRPM
Rotor Moment of Inertia	0.044423	lb-in <sup>2</sup>
Electrical Time Constant	0.96	ms
Mechanical Time Constant	1.8	ms
Phase to Phase Resistance	2.4	Ohms
Inductance	2.3	mH
Motor Weight	1.63	lbs
Shaft Size	8	mm
Motor Rated Temp	40	C
Brake Weight	0.66	lbs
Brake Moment of Inertia	0.00991	lb-in <sup>2</sup>

**Table 1: Servomotor Specifications**

### 3.7 LCD Display

The Intella-Turbine design comes with an LCD display to displays various states and parameters of the overall system. Since the design calls for 8 variables to be measured and displayed, the chosen LCD must have at least 8 lines by 20 characters of displaying capability. The size of the LCD does not have to be big or fancy; it just has to be reliable and durable. Since power consumption is to be kept at a minimum, it is desired that the LCD must have low power consumption and low cost. The Hitachi HD44780 LCD controller is one of the most common dot matrix liquid crystal display (LCD) controllers available today. Hitachi developed the microcontroller specifically to drive alphanumeric LCD displays with a simple interface that could be connected to a general-purpose microcontroller or microprocessor. The device can display ASCII characters, Japanese Kana characters in four 20-character lines. The Hitachi HD44780 has two operating modes, and 8-bit mode and a 4-bit mode. The 8-bit mode is the standard mode but requires the use of twice as much I/O line than the 4-bit mode. The 4-bit mode is more complex but reduces the number of I/O data lines used. In applications where the number of I/O lines available is limited, this operating mode is more suitable. In our design we will implement the 4-bit operating mode to save I/O lines on the microcontroller. Table 2 outlines the desired specifications for the LCD Display.

<b>Pin Number</b>	<b>Purpose</b>
Pin 1	Ground
Pin 2	VCC 5Volts
Pin 3	Contrast Adjustment
Pin 4	Register Select (RS) RS = 0: Command, RS = 1: Data
Pin 5	Read/Write (R/W) R/W = 0: Write, R/W = 1: Read
Pin 6	Clock Enable
Pin 7	Bit 0 Not used in 4-bit operation
Pin 8	Bit 1 Not used in 4-bit operation
Pin 9	Bit 2 Not used in 4-bit operation
Pin 10	Bit 3 Not used in 4-bit operation
Pin 11	Bit 4
Pin 12	Bit 5
Pin 13	Bit 6
Pin 14	Bit 7
Pin 15	Backlight Anode
Pin 16	Backlight Cathode

**Table 2: LCD Display Pin-Out**

## 3.8 Wind Sensors

The sensor that measures wind speed will consist of an anemometer, which is a 3-cup rotor mounted on a vertical shaft. As the anemometer rotates, it should have a reed switch and magnet system that closes the device contacts once per rotation to create a pulse. The frequency of these pulses is proportional to the actual wind speed, and this information will be wired to the output signal of the sensor. From there the actual wind speed can be converted and calculated by the microcontroller to display. The rated speed of this device should optimally fall within a range of 3 to 125 mph, with a rated error of  $\pm 5\%$ .

The sensor that measures wind direction consists of a weather vane that continuously rotates in sync with a freely rotating potentiometer. This device will provide a rated DC resistance of 0 to 20 kilo-Ohms, which is proportional to the actual degrees of rotation that the device is experiencing. The measured voltage value will of course be fed to an input of the data logging microcontroller. Ideally an accuracy of  $\pm 2$  degrees of rotation should be employed by the chosen device.

The sensors for current and voltage, as well as the systems that condition the signals to be compatible with the microcontroller will include an active low pass filter that removes all frequencies greater than one half the sampling rate to eliminate unnecessary aliasing on the analog signal before conversion, which in turn serves to smooth out the signal by allowing a low sampling frequency.

To measure the current being provided by the turbine generator as a result of the surrounding winds, it is desired that the voltage output signal provided by our selected current sensing circuit be within acceptable limits for the input of the microcontroller to handle. This can be accomplished with a variety of methods including a current-sensing shunt resistor, but regardless of the chosen method the signal must be augmented and conditioned to be workable within the digital aspect of the system, as well as to maximize resolution of the analog input to the processor and thus accuracy of the digital measurement once converted by the ADC.

The shunt resistor itself, while overall having a significantly low resistance value, should have a high enough resistance to produce more precise measurements, but at the same time have a low enough resistance to minimize the power draw in the circuit. A typical current-sensing resistor carries a resistance of 100 milli-Ohms or less; for our purposes it is desired that the power this resistor drains should come out to less than 0.1 Watt, all the while maintaining an ADC bit resolution of around 30 mV.

The measurement of the present voltage of the battery system in most cases will require a voltage divider circuit to reduce the large measured voltage of the battery (typically around 24 volts) to a small voltage output signal to be accepted by our microcontroller's input ADC line without overloading and damaging it. An average microcontroller for our purposes will accept a maximum rated voltage on its pins anywhere from 2 to 12 Volts. A table that outlines the desired specifications on our V/C sensors is on Table 3, following.

Parameter	Value	Parameter	Value
Input Voltage	0 to +30 V DC	Input Current	0 to +20 A DC
Nominal Voltage	24.0 to 29.0 V DC	Nominal Current	Conditions will vary due to wind
Output Range	0 to +5.5 V DC	Output Range	0 to +5.5 V DC
Sensitivity	< 0.3 V per unit	Sensitivity	< 0.1 V per unit
ADC Resolution	29.3 mV	ADC Resolution	36.6 mV
Filter Type	Low-pass @ 4 Hz	Filter Type	Low-pass @ 4 Hz
Power Draw	< 0.1 Watt	Power Draw	< 0.1 Watt
Package Type	Plastic Dual Inline	Package Type	Plastic Dual Inline

**Table 3: Voltage and Current Sensor Desired Specifications**

### 3.9 Battery

The battery that was chosen for this design is the lead acid flooded battery. The battery bank will consist of four 6V lead acid batteries put in series to create a 24V system. Each battery is rated at 520Ah at a rate of 20Hr. One phase of the display will show the battery charge status using LEDs. It is a faster than connecting a voltmeter and more practical.

### 3.10 Charge Controller

The design of the charge controller will depend on the charging stages. It will be designed so that when the voltage for the battery is high enough it will switch to the dummy load. The charge controller will also contain voltage regulators to power the different components of the overall system. The charge controller will charge a 24V adjustable battery bank consisting of four 6V batteries. Battery charge status will be determined by LED indicators. The output voltage will be adjustable from 22.5-25V. The batteries are rated at 520Ah at a 20Hr rate so the controller will output a 26A current. The desired charge time of 6 hours would require a current of 86.7A. To obtain maximum efficiency maximum power point tracking will be utilized. When the power is being transferred to the battery at a certain voltage the charge controller must adjust the circuit to deliver the most efficient current.

### 3.11 Inverter

The inverter will convert the 24V battery systems DC current to 60Hz AC. It will match household power characteristics for use of household electronics. As well as being safe to use it must also be an efficient use of power and match the pure sine wave as good as possible.

## 4 Research

### 4.1 Hardware

#### 4.1.1 Alternator

The turbine selection for this project will be the single most important decision the team will have to make. To meet specifications and charge the batteries an alternator capable of producing 1KW at 24 VDC will be necessary. Upon doing research it was found that horizontal axis turbines are more available and efficient than vertical axis turbines. Therefore, this has led to the decision of using a horizontal axis turbine. Multiple turbines were researched, two of which are discussed below.

The first option was the WINDMAX-HY-1000-24 shown below in Figure 2 available from Magnets4less at a cost of \$899.99:



**Figure 2: WINDMAX-HY-1000-24 Turbine  
(Permission Pending from Windmax Green Energy)**

This turbine met the requirements for design. Its output of 1kW at 24VDC, electromagnetic speed limitation and blade over-speed braking, survival speed up to 50mph and rated operational speed of 28 mph made it appear ideal for our project. However, upon further analysis it was discovered that this particular model was going out of production and got poor reviews from our sponsor. Hence with the possibility of lack of support and availability the team decided that the WINDMAX was not the best option.

The second option is the TLG-500 available from TLG Wind Power Products at a cost of \$785. This alternator pictured below in Figure 3 produces 500 watts at 12 or 24 VDC.



**Figure 3: TLG-500 Alternator  
(Permission Pending from TLG Wind Power)**

The TLG-500 cost more than the WINDMAX and to meet the design requirement of 1000 watts two would be needed. This led to a change in our design but the team liked the idea of having two alternators instead of one as this would now allow for some redundancy in the overall system. The TLG-500 has excellent reviews and is said to easily out-perform other alternators of similar or larger specification. The design of the TLG-500 also addresses several inherent issues with other turbines.

This turbine does not produce DC (direct current) straight from the unit as is the case with most turbines. The problem with DC leaving the unit is that it is harder to “transport” meaning getting what you created to your battery bank. There are huge current losses in the wires and the longer the wires the greater the losses. This problem can be mitigated somewhat by using larger wires but this option gets expensive and you will still lose amperage if the run is long.

The TLG-500 produces 3-phase AC (alternating current) from the unit drastically reducing losses during transmission. This makes it possible to also use much cheaper wires such as a regular extension cord available almost everywhere. Once at the battery

bank the AC is converted into DC voltage using rectifiers. Because DC is now transmitted directly to the battery bank losses are greatly minimized.

Another known issue with wind turbines is overheating. The TLG-500 is made from high grade Aluminum alloys, stainless steel, and copper. The overheating problem is addressed by having its windings on the outside edge of its Aluminum alloy case: thus using the entire case as a huge heat sink.

The TLG-500 also addresses other high failure areas in wind turbine designs. It uses two oversized bearings instead of one or two smaller bearings as in most turbines. The bearings are also standard grade steel bearings which last much longer than stainless steel bearings used in other turbines. The alternator is a true brush less design making the bearings the only real moving part inside the alternator. This makes the TLG-500 a very low maintenance turbine and a good choice not only for our design but for anyone looking for a reliable and robust turbine.

## 4.1.2 Full Wave Rectifiers

Intellaturbine will be using DC batteries to store and distribute the output from the TLG-500 wind turbine. The output from the turbine is AC but in order to charge the batteries DC power will be required. Hence the AC output will have to be rectified to produce a DC output. Rectification is a process of converting an alternating voltage (AC) into one that is limited to one polarity (DC). There are two forms of rectification: half-wave and full-wave, with half-wave a simpler design and full-wave being more efficient.

Half-wave rectifiers can be constructed by simply placing a diode between the AC supply and the load. When AC supply alternates polarity the diode will pass half of the waveform blocking the other half. The circuit designer can choose which half passes (positive or negative) by the diode's orientation. Since output voltage only appears for half of the input cycle, the design is called a half-wave rectifier. The DC voltage of an ideal half-wave rectifier can be calculated by the following equation:

$$V_{DC} = (V_{peak})/\pi, \text{ where } V_{peak} = \sqrt{2} \cdot V_{rms}$$

While a half-wave rectifier is easy and cheap to design and build it was concluded by Intellaturbine not to be the AC to DC conversion method of choice because of its inefficiency. As its name suggest, the half-wave rectifier essentially waste half of the available energy provided by the input AC signal. Hence a full-wave rectifier is the AC to DC conversion method to be used.

Unlike the half-wave rectifier, a full-wave rectifier converts both halves of the input signal to one constant polarity at its output. For this design, the circuit designer can also choose which polarity passes by the diode's orientation. The circuit design and construction is more complex than that of the half-wave rectifier as the full-wave rectifier uses more diodes. There are different designs of full-wave rectifiers, the bridge rectifier

design will be used for this project. The bridge rectifier uses four diodes and provides good isolation between the AC input and rectifier output. The DC voltage of an idea full-wave rectifier can be calculated by the following equation:

$$V_{DC} = (2 \cdot V_{peak}) / \pi, \text{ where } V_{peak} = V_{rms} / (1 - 1/e)$$

For three-phase AC which is the output of the TLG-500 six diodes (three pairs) are used. Each pair of diodes is connected in series, anode to cathode. Commercially available diodes typically have four terminals so they can be configured for single-phase split supply, half bridge or three-phase use.

Losses from peak input voltage to peak output voltage in the rectification process is an important aspect. These losses are caused by the built-in voltage drop across the diodes (0.7 v for the typical p-n junction diode and 0.3 v for Schottky diodes). This was a downside in the decision to use a full-wave rectifier, with a half-wave rectifier the voltage drop is just across one diode. However in a full-wave bridge rectifier the voltage drop is that of two diodes. Even with a voltage drop (associated with the diodes) of twice that of a half-wave rectifier, the full-wave rectifier was deemed to be more efficient because the losses due to only passing half of the AC signal was more severe.

Even though the rectification process produces a good form of DC voltage, it is not constant DC voltage because of AC ripple. AC ripple is the unwanted residual periodic variation in the DC output derived from the AC source. This is due to the incomplete suppression of the AC waveform. To fix this problem a smoothing or filtering circuit will be required. This is created by placing a capacitor in parallel with the load and the full-wave rectifier. The size of the capacitor will affect how will the ripple is smoothed out. A larger capacitor will reduce the ripples but it will cost more and create higher peak current in the supply. Ripples can be further reduced by adding a capacitor input filter. This consists of a capacitor in parallel with the rectifier an inductor in series and another capacitor in parallel. For a given tolerable ripple the required capacitor size is proportional to the load current and inversely proportional to the supply frequency and the number of output peaks of the rectifier per input cycle.

The following example of a full-wave rectifier, Figure 4, was modeled in Multisim 8. The circuit was simulated with and without the smoothing or filtering circuit. Modeled first was without, where it can be observed that although there is no longer an AC signal there are large ripples present. This can be seen in Figure 5. Secondly modeled with the filtering circuit connected, the output now resembles a DC signal with only very small ripples present, shown in Figure 6.

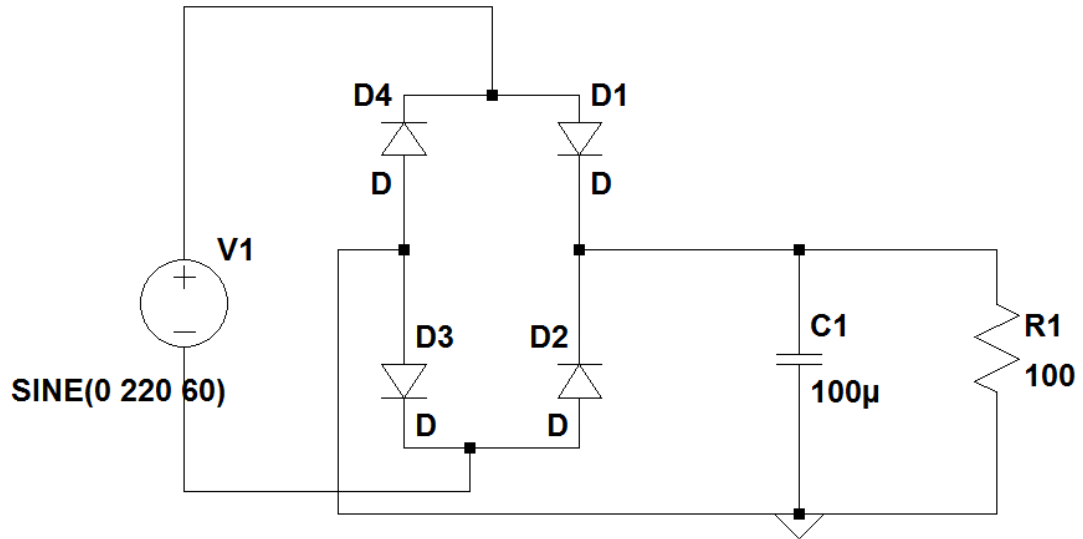

**Figure 4: Bridge Rectifier with smoothing circuit**

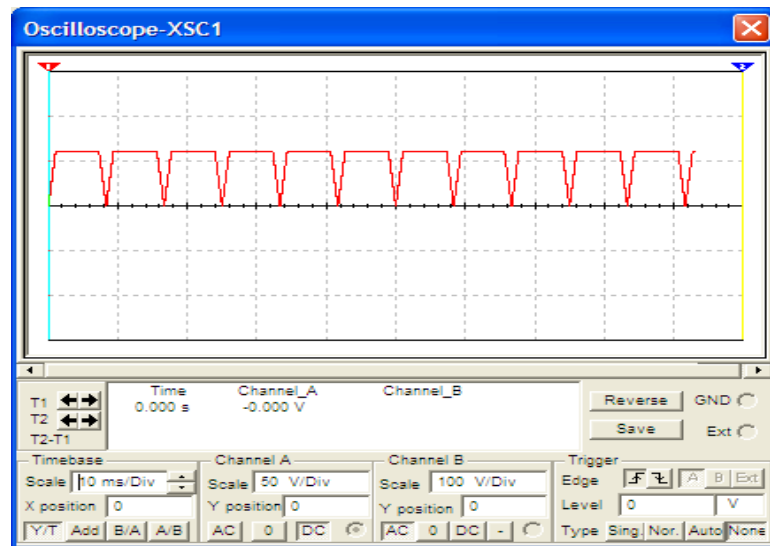

**Figure 5: Output of Bridge Rectifier without smoothing circuit**

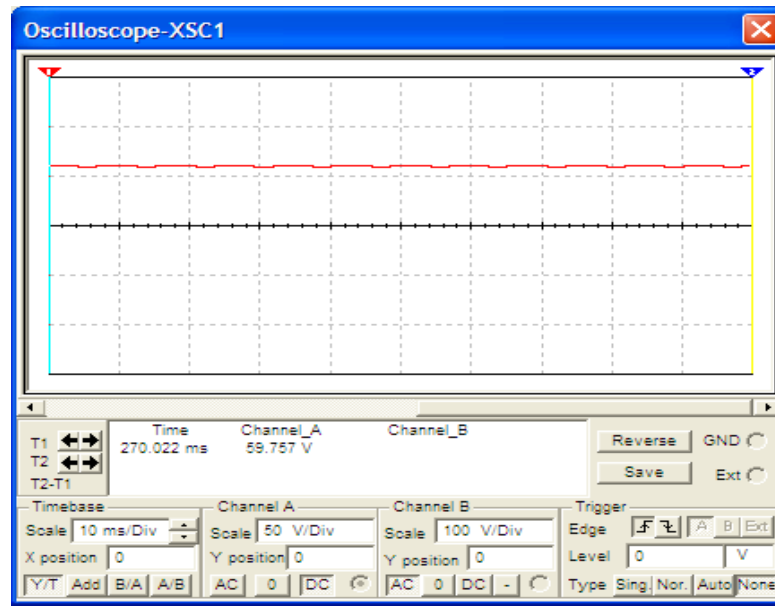

**Figure 6: Output of Bridge Rectifier with smoothing circuit**

### 4.1.3 Voltage Regulation

After rectifying the AC signal to produce a DC signal it will be necessary regulate this signal to charge the DC batteries. While a constant DC voltage is a requirement to charge the batteries, other factors such as charging current and voltage must be adhered to. To operate outside these specifications could damage the batteries and reduce their performance and life span. Voltage regulation will also be a necessity for other aspects of this design to include: microcontrollers, display monitors and DC motors. Each segment will be analyzed separately starting here with the DC batteries.

The simplest way to reduce a DC signal is to use a linear regulator in an integrated circuit (IC) form. The most common types are the TO220 package which is a three terminal IC with the legs protruding from a plastic case with a metal back plate for bolting to a heat sink. The LM78xx (positive voltage) and LM79xx (negative voltage) are common fixed voltage solid-state regulators with the last two digits of the device number indicating the voltage output. By adding additional circuitry, fixed output IC regulators can be made adjustable. Two common ways of doing this is are as follows:

1. Adding a zener diode or resistor between the IC's ground terminal and ground. If the ground current is not constant a resistor should not be used. By switching in different values for the components the output voltage can be made adjustable in a step-wise fashion.
2. By placing a potentiometer in series with the IC's ground the output voltage can be varied. But once again if the ground current is not constant this method will degrade regulation.

Another form of linear regulators is the zener diode regulator. In this design a zener diode is placed in parallel with the load and a regulating resistor is placed in series with the diode and source voltage. Once the current is sufficient to take the zener diode into its breakdown region the diode will maintain a constant voltage across itself. Here the output voltage should remain constant even with a varying output load resistance and the ripple input voltage from the rectified AC signal. For proper operation of this circuit, the power dissipation of the diode must not exceed its rated value, meaning when the current in the diode is a minimum, the load current is a maximum, and the source voltage is a minimum. The inverse of this should also hold true. The minimum designed current should be greater than the minimum zener diode current, which can be estimated to be approximately 1/20 the maximum diode safe operating current. With an appropriate zener diode selected for the voltage drop needed for the battery, the remaining parameters for the circuit can be calculated with the following equations with  $R_i$  the input resistance,  $V_s$  source voltage,  $V_z$  zener diode voltage,  $P_z$  power of the diode,  $I_z$  and  $I_l$  diode and load current respectively:

$$R_i = (V_s - V_z)/I_z + I_l$$

$$P_{z\ max} = V_{z\ max} * I_{z\ max}$$

$$I_{z\ max}/20 < I_{z\ min}$$

$$I_{z\ max} = I_{l\ max}(V_{s\ max} - V_z) - I_{l\ min}(V_{s\ min} - V_z)/V_{s\ min} - 0.9V_z - 0.1V_{s\ max}$$

The zener diode regulator can be made to regulate much better by adding an emitter follower stage which forms a simple series voltage regulator. In this circuit the load current is now connected to a transistor whose base is connected to the zener diode. The transistor base current ( $I_B$ ) now forms the load current for the zener diode and is much smaller than the load current. This forms a very light load on the zener minimizing the effects of variation in the load, it is still however, sensitive to load and supply variation. It is also important to note that the output voltage will always be about 0.6V to 0.7V less than the zener because of the transistor  $V_{BE}$  drop. The circuit is referred to as series because the regulating elements (transistor and diode) are in series with the load.  $R_i$  still determines the zener current and can be calculated by the following formula where  $h_{FE\ min}$  is the minimum acceptable DC current gain for the transistor and  $K$  is equal to 1.2 to 2 which ensures  $R_i$  is low enough for an adequate  $I_B$ :

$$R_i = (V_s - V_z)/I_z + K \cdot I_B$$

$$I_B = I_l/h_{FE\ min}$$

An example of the zener diode regulator with emitter follower is modeled in Multisim 8 on the next page, in Figure 7:

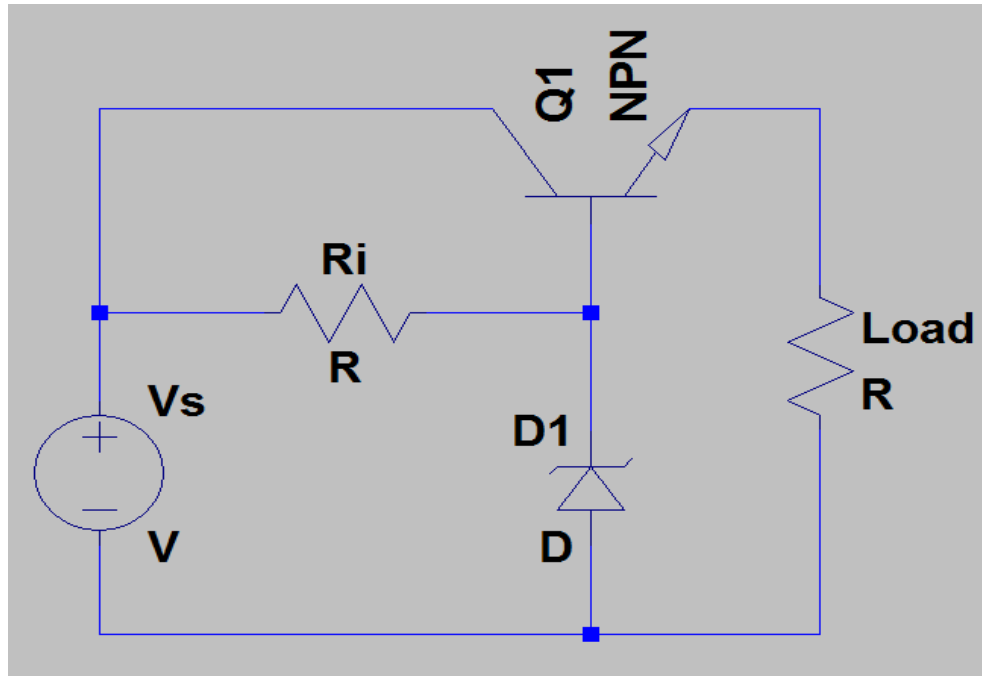

**Figure 7: Zener Diode Regulator with Emitter Follower**

Linear regulators whether in the integrated circuit or diode form are cheap, readily available and reliable. They are also simple to design and implement. There are drawbacks to linear regulators however; they are not very efficient as they waste a lot of energy by heat dissipation. This loss of energy by heat will be very pronounced here because of the high current that will be produced by the alternators. With  $P = I^2R$ ,  $I^2$  being the driving force for the loss in energy by heat, it can be easily seen that the loss will rise exponentially. The compact size of an IC could be a disadvantage because all the heat would be dissipated in a concentrated area. There are also other factors that will disqualify the use of linear regulators for the charging/regulating of the batteries. There will be a large voltage difference between the alternators and the batteries, linear regulators are not usually well suited for this situation and as such they would not be used here. Linear regulators will be used for the micro-controllers and display segments of the design.

The final type of voltage regulator to be evaluated will be the buck converter. The input of a DC-DC converter is an unregulated DC voltage  $V_s$  with the output  $V_L$  being regulated to some value different from  $V_s$ . To regulate the rectified voltage from the alternator a buck converter will be used. Buck converters can be remarkably efficient compared to an integrated circuit with 95% or higher making it the ideal choice for this design. The operation and design of a buck converter is reasonably simple. It has two switches, usually a transistor and a diode which controls an inductor, connecting it to the source voltage where it stores energy then to the load where it discharges. Pictured on the next page is Figure 8, a diagram of a buck converter.

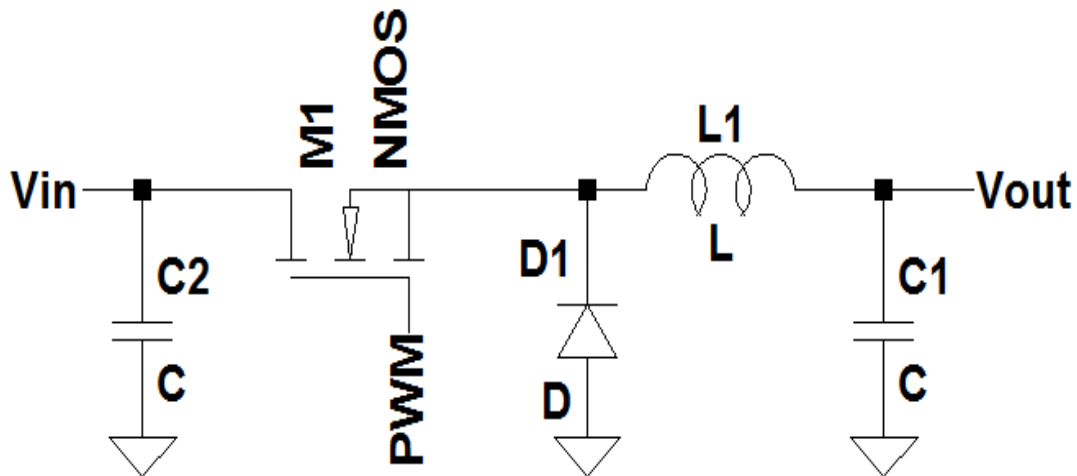

**Figure 8: Buck Converter**

From the diagram, when in the on-state the diode is reversed biased by the source allowing no current to flow through it. The voltage across the inductor now becomes  $V_L = V_i - V_o$  and the current  $I_L$  raises linearly. In the off-state the diode is now forward biased and the voltage across the inductor now becomes  $V_L = -V_o$  the current  $I_L$  decreases and the energy stored in the inductor is equal to  $E = \frac{1}{2} L * I_L^2$  assuming an ideal situation and neglecting diode voltage drop. The rate of change for  $I_L$  can now be calculated from  $V_L = LdI_L /dt$  with  $V_L$  of the on/off-state. The load capacitor is used to reduce ripple to the load just as in the rectifier. The series of equations below will be used to calculate the values of the components needed to design and build a buck converter where  $D$  is the duty cycle,  $F_{sw}$  is the switching frequency,  $V_{in}$  is the rectified input,  $V_{out}$  the desired voltage output,  $I_L$  the load current and  $I_R$  the ripple current (typically 30%),  $L$  the inductor and  $C$  capacitor:

$$D = V_{in}/V_{out} \quad I_R = 0.3I_L$$

$$L = (V_{in} - V_{out})(D/F_{sw})/I_R$$

$$C = (\Delta I * \Delta T)/(\Delta V - (\Delta I * ESR)), \text{ where } \Delta T = D/F_{sw}$$

For the diode and MOSFET selection, the following equation can be used:

$$I_D = (1 - D)I_L$$

By knowing the current and the voltage, a diode can be selected from a data sheet. The power dissipation can be calculated with  $V_F * I_D$ . A MOSFET would be selected for ease of driving gate.

## 4.1.4 Battery

All deep cycle batteries are rated at Ampere-Hours. An amp-hour means one amp for one hour. Amp-Hours are specified at a particular rate because of the Peukert Effect. German scientist W. Peukert expressed the capacity of batteries in terms of the rate of which it is discharged. The Peukert value is directly related to the internal resistance of the battery. The higher the internal resistance, the higher the losses while charging and discharging, especially at higher currents. This is converted to heat which is why batteries get hot when being charged up. Therefore slower charging and discharging rates are more efficient. The typical lead acid battery efficiency is 85-95%. Other batteries such as NiCad is about 65% and true deep cycle AGM can approach 98% under optimum conditions, but in general there is a 10% to 20% total power loss when sizing batteries and battery banks.

Rechargeable batteries are known as secondary cells because their chemical electrochemical reactions are electrically reversible. Their impact on the environment is much less than disposable batteries. There are many different types of rechargeable batteries which are classified based on the chemical reaction they use such as sealed lead acid, lithium ion, nickel metal hydride. Considerations for the type of battery are maintenance cost and battery life. One of the oldest rechargeable battery systems is the lead acid system. It is durable and has a low specific energy. Its major advantage is that it is really simple to determine the state of charge by measuring the specific gravity of the electrolyte. The nickel-cadmium batteries characteristics are that it has a long service life and high discharge current. Due to environmental concerns the nickel-cadmium is being replaced with other chemistries. Its applications are power tools and two-way radios. The nickel-metal hydride has a higher specific energy with fewer toxic metals. It is used for medical instruments and hybrid cars. One of the most promising battery systems is the lithium-ion. It is more expensive than nickel and its applications are well known. Figure 4 shown below describes very useful information and was essential in choosing the battery type. The lead acid battery has a high overcharge tolerance, optimal charging time and shorter maintenance time. A trade-off is its high toxicity.

Over-charging, Undercharging, deep discharging and low electrolyte levels can cause lead acid batteries to fail prematurely. High internal resistance and failure are due to sulphation, crystallization of lead, of the plates. Fortunately for lead acid batteries the process can be reversed using a desulphation method. Desulphation reverses the chemical reaction and reconditions the battery as long as all of the cells are not shorted. When the lead acid crystals build up on the plates removing them becomes a very difficult task because as more crystallization occurs more voltage is needed to dissolve them back into the electrolyte. However putting a large voltage on the battery will cause an explosion. Instead, pulse conditioning can be used to make sure the battery does not overheat. This process can take weeks and the battery must be trickle charged to restore its full charge.

Figure 9 on the following page outlines the characteristics of each different battery system.

Specifications	Lead Acid	NiCd	NiMH	Li-ion		
				Cobalt	Manganese	Phosphate
Specific energy density (Wh/kg)	30–50	45–80	60–120	150–190	100–135	90–120
Internal resistance <sup>1</sup> (mΩ)	<100 12V pack	100–200 6V pack	200–300 6V pack	150–300 7.2V	25–75 <sup>2</sup> per cell	25–50 <sup>2</sup> per cell
Cycle life <sup>4</sup> (80% discharge)	200–300	1000 <sup>3</sup>	300–500 <sup>3</sup>	500–1,000	500–1,000	1,000–2,000
Fast-charge time	8–16h	1h typical	2–4h	2–4h	1h or less	1h or less
Overcharge tolerance	High	Moderate	Low	Low. Cannot tolerate trickle charge		
Self-discharge/month (room temp)	5%	20% <sup>5</sup>	30% <sup>5</sup>	<10% <sup>6</sup>		
Cell voltage (nominal)	2V	1.2V <sup>7</sup>	1.2V <sup>7</sup>	3.6V <sup>8</sup>	3.8V <sup>8</sup>	3.3V
Charge cutoff voltage (V/cell)	2.40 Float 2.25	Full charge detection by voltage signature		4.20		3.60
Discharge cutoff voltage (V/cell, 1C)	1.75	1.00		2.50 – 3.00		2.80
Peak load current Best result	5C <sup>9</sup> 0.2C	20C 1C	5C 0.5C	>3C <1C	>30C <10C	>30C <10C
Charge temperature	–20 to 50°C (–4 to 122°F)	0 to 45°C (32 to 113°F)		0 to 45°C <sup>10</sup> (32 to 113°F)		
Discharge temperature	–20 to 50°C (–4 to °F)	–20 to 65°C (–4 to 49°F)		–20 to 60°C (–4 to 140°F)		
Maintenance requirement	3–6 months <sup>11</sup> (topping chg.)	30–60 days (discharge)	60–90 days (discharge)	Not required		
Safety requirements	Thermally stable	Thermally stable, fuse protection common		Protection circuit mandatory <sup>12</sup>		
In use since	Late 1800s	1950	1990	1991	1996	1999
Toxicity	Very high	Very high	Low	Low		

**Figure 9: Battery Characteristics**  
(Reproduced with permission from Cadex Electronics Inc.)

There are three stages involved in charging lead acid batteries. The first stage is the bulk charge which applies to the bulk of the charge and takes up about half of the required charge time. The maximum safe current is used to charge the battery until it reaches 80-90% charge. The maximum safe current is limited by the wire or battery but there is no set voltage for bulk charging. Second is the absorption charge which continues charging at a lower current and provides saturation. Voltage is kept constant in this stage while the current decreases. Lastly is the float charge stage which adjusts for the loss caused by self-discharge. During this stage the charging voltage is slightly reduced to reduce gassing and the current is reduced to less than 1% of the battery capacity. Figure X shows a graph of the charging stages of 2V cell batteries. Typical self-discharging rates are 5% to 15% per month. Pulse width modulation does the same thing by sensing very small voltage drops and sends short charging cycles to the battery. Most garage type battery chargers are bulk charge only and seldom have regulation. Figure 10 charts the charging stages of the battery.

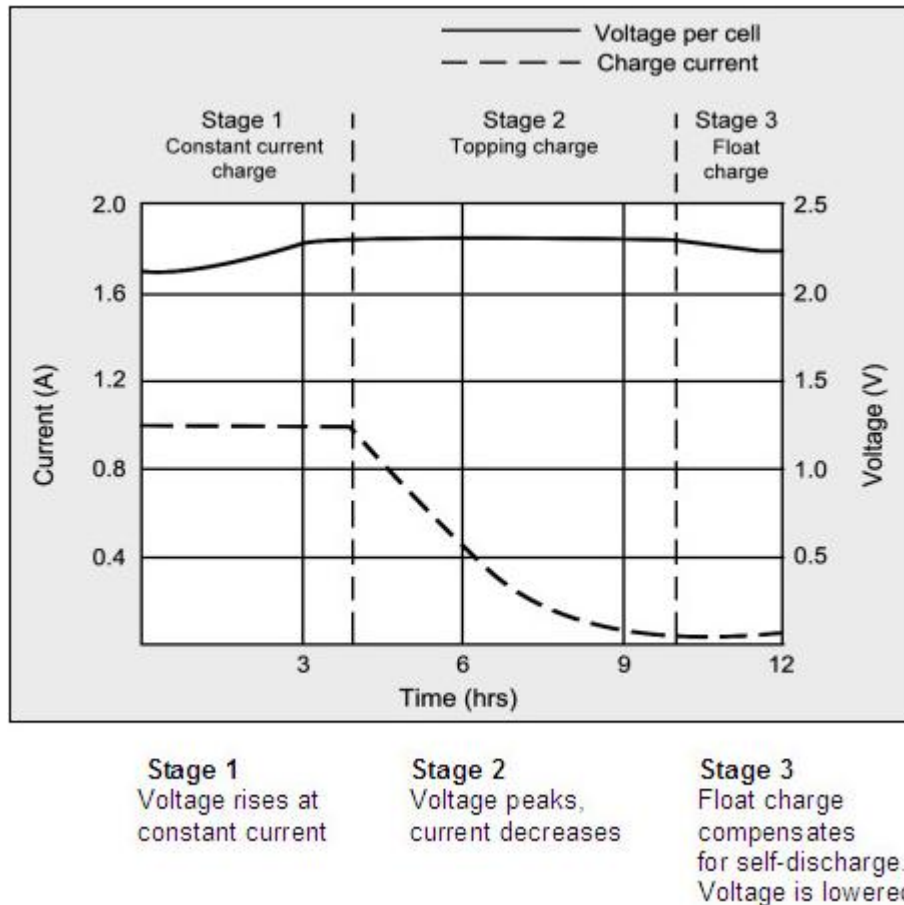

**Figure 10: Deep Cycle Battery Charging Stages  
 (Reproduced with permission from Cadex Electronics Inc.)**

Anything above 2.15VPC (volts per cell) will charge a lead acid battery. If the voltage is too high, gassing voltage, it will limit how high the voltage can go before producing undesirable chemical reactions in the battery. Hence, the typical charging voltage is

between 2.14 (6.42V for a 3 cell battery) and 2.35 (7.05 for a 3 cell battery) VPC. For a fully charged battery these voltages, float voltages, are sufficient to prevent damage and overcharging. Much higher voltages can be used if the battery is not fully charged because the charging reaction takes precedence over any overcharge chemical reactions. A battery is considered dead when it has 1.75VPC (21V in a 24V system). Lead acid batteries have to be fully charged to achieve satisfactory performance. The depth of discharge (DOD) can be determined by measuring the specific gravity with a hydrometer. Most flooded batteries should be charged at no more than the C/8 rate for any sustained period. Table 1 shows the charge percentage of the volts per cell, the individual 6V batteries and the 24V battery bank. Once the charging voltage reaches 2.583 volts per cell the trickle charge stage must be employed. Flooded battery life can be extended if an equalizing charge is applied every 10 to 40 days. The equalizing charge is about 10% higher than the normal full charge voltage and applied for 2 to 16 hours. This makes sure all cells are equally charged. Table 4 includes the battery charging information.

State of Charge	Battery Voltage	System Voltage 24V	Volts Per Cell
100%	6.42	25.68	2.14
90%	6.30	25.21	2.10
80%	6.19	24.74	2.06
70%	6.07	24.28	2.02
60%	5.95	23.81	1.98
50%	5.84	23.34	1.95
40%	5.72	22.87	1.91
30%	5.60	22.40	1.87
20%	5.48	21.94	1.83
10%	5.37	21.47	1.79
0%	5.25	21.00	1.75

**Table 4: Charge in Single Battery and System**

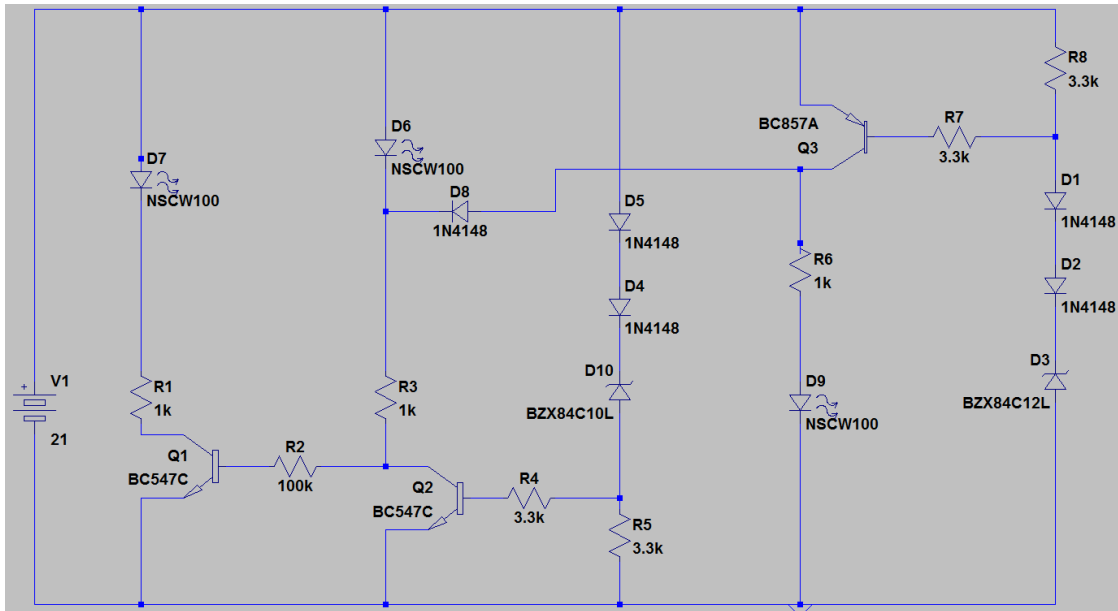

**Figure 11: BJT battery monitor**

There are many different circuits for battery monitoring. Many of them used comparator and LEDs to display the level of charge. There are a large amount of LEDs used in some of the more popular circuits. Another interesting circuit, diagrammed in Figure 11 above, uses BJTs to drive current into a diode that flashes when the battery is charged. The circuit is composed of 3 different transistors and 7 diodes. It uses red, yellow and green LEDs to display the charge status. When the voltage becomes below the threshold the LED turns fades and turns off. Although it is a fairly simple circuit it is costly. A more eye catching configuration is the LM3914 battery monitoring circuit, shown in Figure 12 on the following page, which uses 10 LEDs to display the status of the battery. It is cheaper than the BJT circuit because it uses one IC and is also less complicated. This circuit, unfortunately, has to be calibrated with a voltage regulator. The configuration below will light up the LEDs in dot mode and if or a 12v system. Two LM3914 ICs can be cascaded for an even larger charge display.

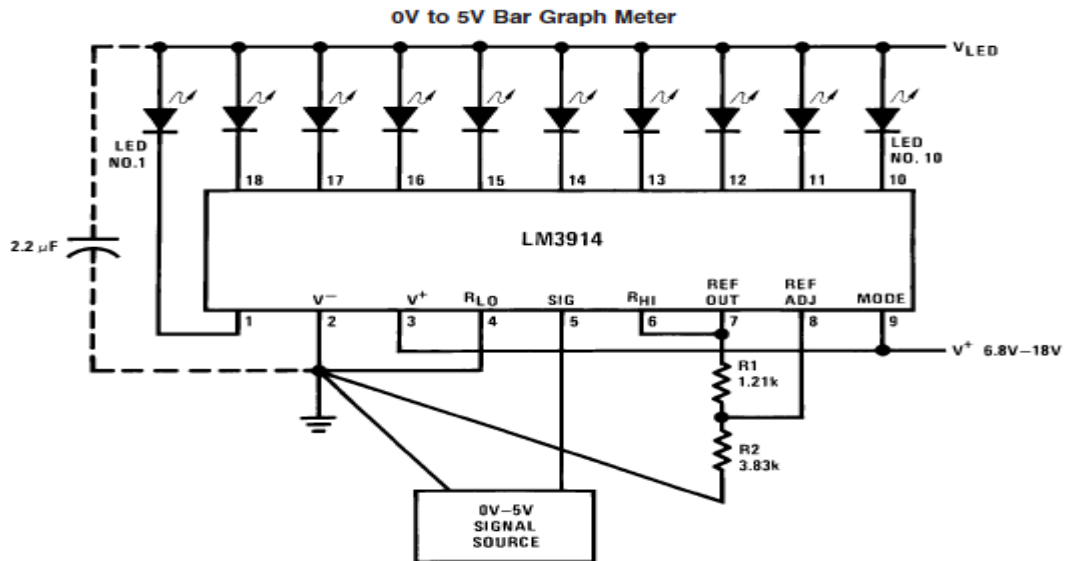

**Figure 12: LM3914 Ten LED battery monitoring system  
(Used in accordance with Texas Instruments copyright)**

Wind turbines are designed to always be under a load. The load is constantly drawing electricity from the turbine's generator. If a wind turbine operates under no load it can damage its components or worst case scenario self-destruct in high wind conditions. There is no turning off the wind when the battery is charged. When the battery bank reaches full charge it is disconnected from the turbine to prevent overcharging. At that point a dummy/diversion load is inserted in place of the battery bank to continue drawing power. To determine the size of a dump load system you must know the voltage of the system and how many amps the turbine will produce at maximum power. The dump load system needs to be capable of dumping the maximum power of the wind turbine being used.

## 4.1.5 Charge Controller

Charge controllers are the most important part of an energy based electrical system. Basic charge controllers keep the battery from being overcharged and protect it from reverse current. They also display battery status and the flow of power. Charge controllers are also safe operating devices that prevent heavy current flow that can cause fires or even explode the battery. When the battery reaches full charge the charge controller must limit or stop the flow. In charge controllers the charge current is passed through a semiconductor, transistor, which prevents it from flowing in the wrong direction. Charge controllers also use these semiconductors to monitor the voltage and current and restrict, limit, or reroute them based on the design.

More complicated charge controllers have switching modes for specific purposes. Some charge controllers use switches to perform different tasks such as changing from one load to another. Charge controllers use relays or semiconductor devices as switches to perform the different task tailored for a specific purpose. When designing a charge

controller it is important to know what would best suit your needs. Relays and transistors have their advantages and disadvantages. Relays use more power by switch higher currents better but at a slower rate. Charge controllers regulate the flow of energy by switching the current on or off. Others used semiconductor devices such as BJTs to gradually decrease the current. A charge controller must power the electronics while using up the least amount of energy. Average charge controller efficiency ranges from 94% to 97%. Overall, charge controllers are designed to be an effective means of transferring energy safely and efficiently.

Some of the charging circuits shown for wind turbines use relays to switch the charging the battery to charging the dummy load. Switches are also used for specific purposes in a control system so choosing the best one is important. Two main characteristics to look for are power consumption and switching time. A relay is an electrically controlled switch that creates a magnetic field when current flows through a coil which attracts a lever that changes the switch contacts. The link in the relay is magnetic and mechanical there is no electrical connection. The coil of a relay passes a large current. Relays produce a high voltage when switching so a protection diode for the transistors and ICs is put in parallel with the relay. However, relays require more current than IC's can provide. The advantages and disadvantages of relays include:

- Advantage of Relays
  - Can switch AC and DC
  - Can switch higher voltages
  - Can switch multiple contacts at once
  - Better for switching very large currents
- Disadvantage of Relays
  - Bulkier
  - Require more current
  - Cannot switch rapidly
  - Require ICs to operate them

Relays are also classified as electromagnetic relays (EMR) and solid state relays (SSR), which are transistors. Another relay is that can be useful in the wind turbine is a contactor which is a heavy-duty and generally used in electric motors. These aspects will come into play in the circuit design.

The LM2678 can be used as a 5V buck switching regulator. It can provide all required elements of a buck regulator and can drive up to 5A loads. The IC is more than 90% efficient and has good load line regulation. Some drawbacks are that it heats up so a heat sink is highly recommended and the feedback wire must be as far away as possible from the inductor. Figure 13 on the following page shows a sample battery charger circuit using the LM2678.

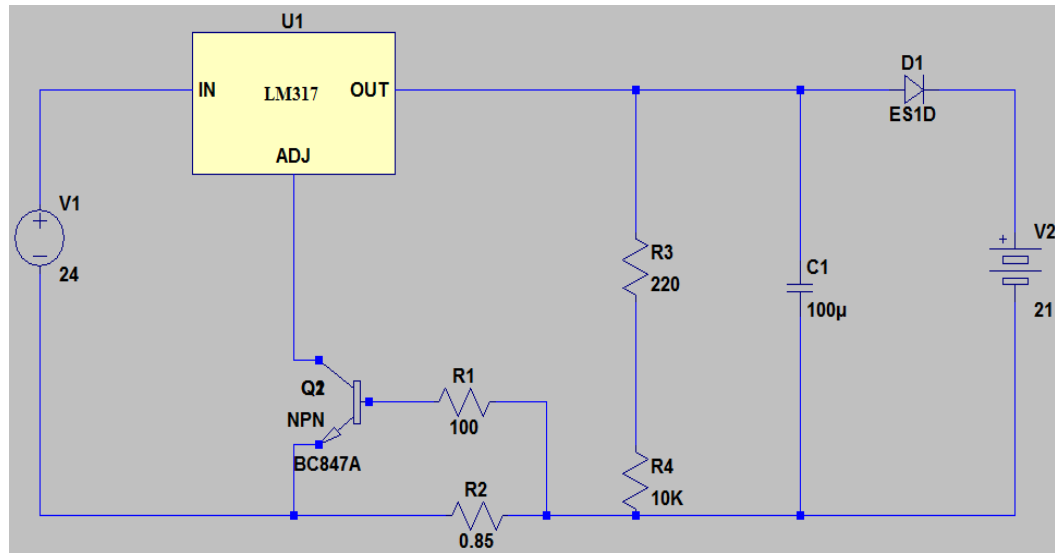

**Figure 13: Sample LM317 Battery charger circuit  
(Based on circuit at <http://www.circuitstoday.com/24v-lead-acid-battery-charger-circuit>)**

The LM317 adjustable regulator can be used to regulate the charging current as opposed to the voltage regulation of the LM7808 which is a possible design feature. Resistor R4 is actually a 10K $\Omega$  potentiometer. Linear regulators are cheap and good for powering very low powered device. They are used to maintain steady voltage and react fast to voltage changes in the input. The controlling element of a linear regulator is an active device, such as a BJT or FET, operating inside the active region. A linear regulator takes the difference between the input and output voltages and burns it as heat. The larger the difference the more heat produced. Linear regulators are not efficient at transferring power. However, a switching regulator works by taking small amounts of energy from the input voltage source, and moving them to the output. The energy losses produced when using this method is relatively small. Switching regulators have about 85% efficiency compared to a linear regulator's 40%. They are a much more efficient mode of power transfer and preferred over linear regulators. Unfortunately, switching regulators are complex circuits to design but there are some switching regulators that are more easily implemented than linear regulators. Another drawback of a linear regulator is that they require a step down transformer. This problem is solved by using switching regulators. This operation requires a transistor to perform as a switch so the transistor is operated in the cut-off region or in saturation region therefore resulting in much less power dissipation in the pass transistor. Switching regulators can provide large load currents at low voltages.

One of the main advantages that switching regulators have over linear regulators is that they can step up voltage which is impossible for any linear regulator. There are three basic configurations of switching regulators that are available: step up, step down and polarity inverting. The LT1072CN8 buck boost converter circuit has a 15-35V input voltage and a 28V output which would be acceptable for a 24V system.

## 4.1.6 Maximum Power Point Tracking

Maximum Power Point Tracking is needed to optimize the amount of power being delivered to the battery system. Maximum power point trackers can implement different algorithms and switch between them depending on its states. Several methods are available for wind generators that can increase efficiency. Wind generator power production can be optimized by changing the mechanical characteristics such as pitch blade angel. Unfortunately, such a modification will require special construction and may not be available. Another method is to measure the wind generator output power and derive the target rotor speed for optimal power generation from the wind generator's optimal power versus rotor-speed characteristics. In permanent-magnet wind systems the voltage is proportional to the rotor speed and the output current is proportional to the electromagnetic torque. The output voltage is used to calculate the rotor speed and the current versus rotational-speed characteristics are used to calculate the output current. All of these methods are based on the wind generator characteristics. Below is the equation for wind power that is transformed into mechanical power.

$$P_m = \frac{1}{2} \pi \rho R^2 V^3 C_p(\lambda, \beta)$$

$P_m$  is the power that is converted into rotational energy by the wind. It is a function of the blade shape, pitch angle, radius and rotor speed of rotation. However, these quantifying characteristics may not be available which puts these methods at a disadvantage. An alternative approach for MPPT process is based on using measurements of wind generator output voltage and output current and adjusting the duty cycle of the DC/DC converter according to the comparison between successive generator power values. The block diagram for this system is illustrated in Figure 14.

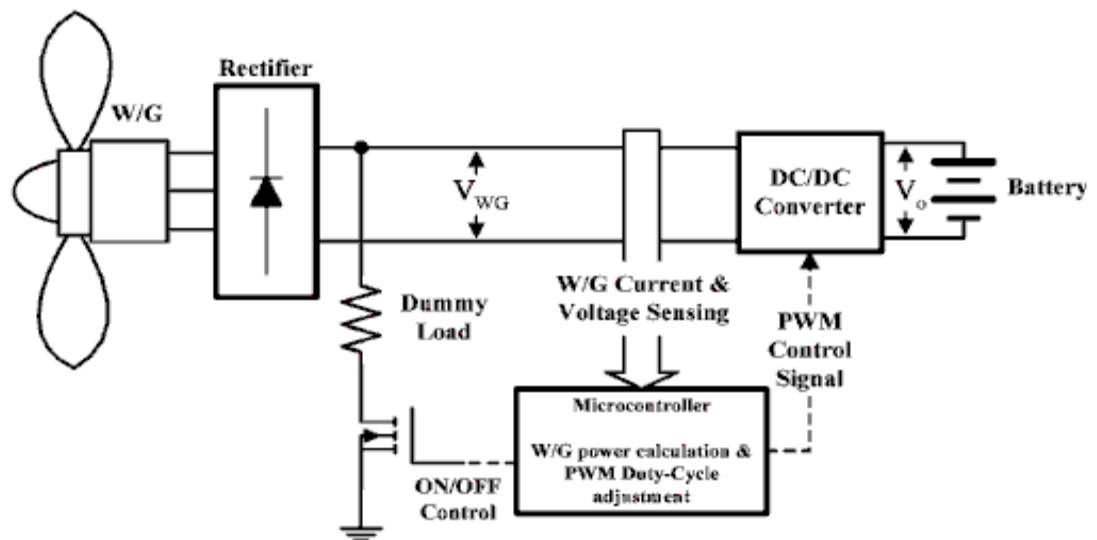

**Figure 14: MPPT based on voltage and current  
(Figure used in accordance with IEEE copyright)**

MPPT controllers use DC-DC conversion to ensure maximum power is transferred. A switching regulator is an efficient IC for this task. The problem with charging the battery system is that there will not be an efficient transfer of power. This happens because the voltage in the battery bank is low and so is the ampere being delivered to the system. MPPT will change the input voltage to make the power rating closer to what the wind turbine is rated.

Since such a high current is needed for efficient energy transfer the wires are now a very important and critical part of the design. Safety becomes the most important aspect when working with large currents. It only takes about 70-700mA to cause fibrillation but large currents, greater than 1A can kill. Safety is only one of the three considerations in selecting wires. The other two concerns are voltage drop and power loss. Under-sizing the wire will cause a voltage drop that the turbine will have to compensate for by speeding up to maintain minimum voltage. The extra work will put unwanted stress on the turbine. A drop in the voltage would also mean a power loss for the system. The National Electric Code has established the safe operating current for wire gauge sizes when using different currents. The wires are rated AWG, American Wire Gauge, and with a target current of about 8A the minimum safe gauge rating for Intellaturbine is 2AWG with a maximum ampere capacity of 94A. Because this is an approximation other AWG values are shown in Table 5.

<b>AWG Gauge</b>	<b>Conductor Diameter in Inches</b>	<b>Ohms Per 1000ft.</b>	<b>Maximum Amps for Power Transfer</b>
<b>1</b>	0.2893	0.1239	119
<b>2</b>	0.2576	0.1563	94
<b>3</b>	0.2294	0.1970	75
<b>4</b>	0.2043	0.2485	60
<b>5</b>	0.1819	0.3133	47
<b>7</b>	0.1443	0.4982	30
<b>10</b>	0.1019	0.9989	15
<b>12</b>	0.0808	1.588	9.3

**Table 5: AWG wire gauges  
(Data from [powerstream.com/Wire\\_Size.htm](http://powerstream.com/Wire_Size.htm))**

From the data provided about the wind turbine at the initial speed the turbine will produce 1A. So at 24V that means 24 watts of power. The goal is to match the output power from the turbine to the input power of the battery. If the battery is not fully charged, say at 21V and the turbine is outputting 1A then the power into the battery is only 21 watts. MPPT will adjust the DC-DC converter to match the power output from the turbine as best as possible. Therefore, at battery at 21V needing 24W of power needs  $I = 24/21=1.14$  Amps. The MPPT will adjust the DC-DC output so that the output voltage and output current is as close as possible to the power coming in. The problem with 1.14A is that to match that the output voltage of the DC-DC converter would have to be 21V but to charge a battery the voltage has to be higher than the battery. Therefore an algorithm will be needed to calculate a higher voltage to charge the battery. Four common and effective methods that are used mainly for PV arrays but can be implemented in a wind system are:

- Perturb and Observe
- Incremental Conductance
- Constant Voltage
- Load I or V Maximization

The Perturb and Observe method is the most commonly used method due to its ease of implementation. In this method the voltage from the array is increased so that the output power increases. This is done until the output power starts to decrease. This method depends on the rise of the curve of power against voltage below the maximum power point, and the fall of the curve of power above that point. One main disadvantage of perturb and observe is that the power will oscillate because the tracker cannot discern when it is at the maximum so instead it is always either increasing or decreasing. Because of this the Perturb and Observe method is also referred to as the hill climbing method.

The incremental conductance method uses the fact that the slope of the IV curve is zero at the maximum power point. This algorithm sets the derivative of the PV array power with respect to voltage to zero and with this it can derive an equation that can determine if the array is operating above or below its maximum power point. The maximum power point is done by comparing the instantaneous conductance to the incremental conductance. This method can track changes better than the perturb and observe algorithm but it requires more computing power. Unlike the perturb and observe method the incremental conductance method can determine when it is at the maximum power point therefore, the power will not oscillate. In addition, incremental conductance can track the maximum power point even in rapidly changing conditions.

The constant voltage method uses the open circuit voltage and the voltage at the maximum power point and calculate a ratio,  $k = V_{OC}/V_{MPP}$ . The ratio is then used as a percentage that is multiplied by the measured  $V_{OC}$ . This new value is then set as the operating voltage. Although the operating voltage can be found quickly for this method its accuracy is not high. Furthermore it requires that the open circuit voltage be measured resulting in loss of energy when the circuit is disconnected.

When a PV array is connected to a power converter, the output power at the load of the converter is maximized as you maximize the power of the PV array. Many loads are similar to a voltage source, a current source, a resistor, or a combination of all. If a voltage source is the load the current load should be maximized to obtain the maximum output of power. On the other hand if the load is a current source type then the voltage should be maximized to achieve the maximum power output. All of these different source types can be controlled by using increasing the current or voltage. Furthermore, only one sensor will be required. For the battery source type the load current would be the control variable. Feedback is used to control the power converter so that it uses a value close to the maximum power point load current. This is the simplicity of the load I or V maximization method.

## 4.1.7 Inverter

For the battery bank to be useful it has to be able to power household electronics. It cannot do that with DC power therefore an inverter is required. An inverter is an electrical device that can convert DC to AC. The converted current can be at any frequency and may not be a pure AC current. Solid state inverters are used in countless applications that range from small switching power supplies to large electric utility high voltage DC applications such as wind turbines. There are many different kinds of inverters for many different situations. As with any electrical component they are named after the characteristics they portray.

The square wave inverter is named so because it does not produce a sine wave but it produces an alternating square wave. Although it is the cheapest to make it produces a high harmonic content making it unsuitable for most AC loads. A modified sine wave inverter produces a sine wave similar to a square wave but the output has dead spots between the positive and negative half cycles. Like the square wave inverter it is cheap and can be used with many electronic devices. A pure sine wave inverter produces an almost perfect sine wave that is the same as utility supplied grid power. Pure sine wave inverters are compatible with all AC electronic devices. This topology costs more per unit power and is much more complex. The stand-alone inverter is mainly used to convert the direct current from renewable energy sources such as photovoltaic panels and wind turbines. They are mostly remote and not connected to a utility grid. A grid tie inverter on the other hand is designed to connect to the grid and so it must synchronize with the frequency of the grid. They usually contain MPPT features for maximum power. In power electronics inverters usually work with PWM waveforms which have high harmonic contents. The harmonics cause increasing losses, load malfunction and EMI noise, which is just a few drawbacks. Harmonics flow to low impedance devices so many of the harmonic filters that are used are LC filters. Low impedance devices extract harmonics throughout the system and dissipate them as heat which is energy loss. Low impedance devices are passive and an alternative to passive devices are active devices. Active devices cancel harmonics by producing them at a 180 degree phase angle to the harmonics being created by the system.

A basic inverter design includes a transformer and a switch. A DC current is driven through the center of the primary winding and the switch rapidly switches back and forth, as the inductor charges and discharges, allowing the current to go back to the DC source. The inverting current direction produces alternating current. Recent inverter designs use pulse width modulation to produce a pulsed waveform that can be filtered easily to achieve a good approximation to a sine wave. The advantage of PWM is that the switching techniques result in high efficiency. Significant control circuitry and high-speed switching are required to make the pulse width vary according to the amplitude of a sine wave. This is because the PWM signal has to be filtered out effectively so the frequency of the PWM has to be much higher than the frequency of the sine wave to be synthesized. Filtering for the modified sine wave inverter can be further augmented to produce a more approximate sine wave by assimilating another waveform to remove the unwanted harmonics. The switching stage could be implemented with a combination of bridge and half bridge components. Some DC-AC inverters are also designed using the popular 555 Timer IC. The 555 inverter in Figure 15 connects the IC in mono-stable mode and uses it as a low frequency oscillator. It has a tunable frequency range of 50-60Hz using the potentiometer. It feeds output through two transistors to the transformer. The circuit suggests that it produces a virtual sine wave due to the fact that the capacitor and coil filter the input.

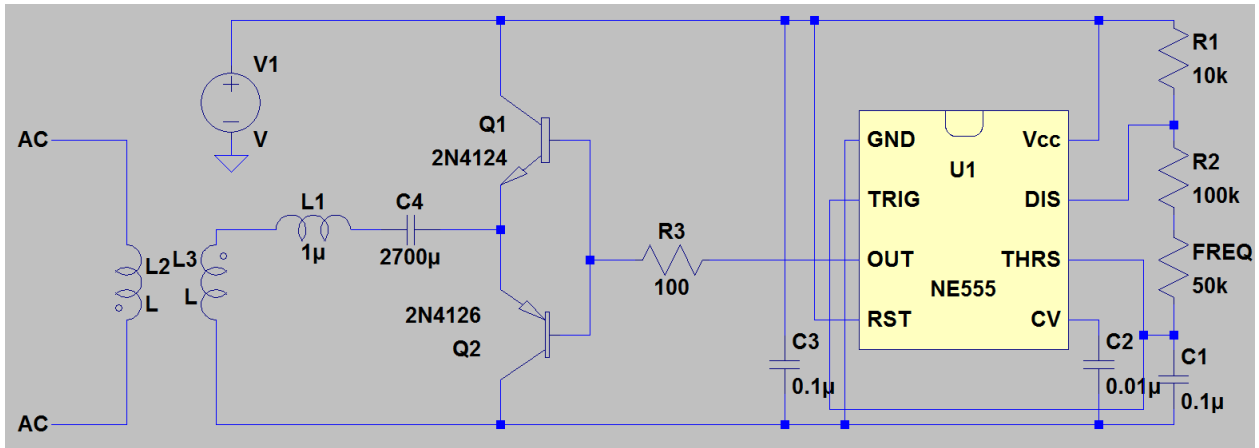

**Figure 15: 555 Inverter Circuit**

### 4.1.8 Efficiency

The typical efficiency of a wind turbine is less than 50%. Less than half of the wind energy would be converted into mechanical energy. The maximum possible percent efficiency that can come out of any wind turbine design was theoretically calculated, by physicist Albert Betz, to be 59%. Therefore the efficiency will be calculated from the power going into the charge controller and the power leaving it. Maximum power point tracking will be utilized so that the most power is transferred from the turbine.

## 4.1.9 Microcontrollers

Upon attending several technology seminars for microcontrollers held by their respective companies, several choices were presented to us in the realm of digital computing. The Texas Instruments® MSP430™ Value Line of microcontrollers was presented to us as a variety of low cost, low power microcontroller solutions to suit our needs. Additionally, some research was done on our part into other low-cost solutions from the Microchip® PIC18 series of microcontrollers including the PIC18F45K22, and from the Atmel® ATmega family including the ATmega168 and ATmega328 MCUs, that may use various development models for coding purposes. In the following sections we will explore and summarize the features of each of these microcontrollers and how they may or may not benefit the Intellaturbine project.

For the data logging aspect to be fully realized, some considerations must be made as to whether we use an SD card or a portable USB thumb drive for a portable storage medium. If an SD card is used, some additional hardware will be required for the interface with the SD and an extensive software library (which is available at the time of this writing) that enables the SD's file system to interact with the microcontroller and have the data be written in an understandable format to be analyzed using various spreadsheet programs such as Excel™. If a USB interface is utilized, the flash memory in the USB device may natively support the data being sent from the microcontroller, but a program must then be written on the PC software level to export the data into a format compatible with the aforementioned data spreadsheet software. The advantages and disadvantages of a SD storage medium vs. a USB storage medium will also be explored.

Another consideration for our project was time keeping on the data logging system. Optimally, for each piece of data that is recorded by the microcontroller, a time stamp that notes what time of day the data was logged is extremely useful. On traditional microcontroller chips, there is a built-in oscillator that keeps the time. However, this function usually only serves to measure the time since the chip was last powered on. One may program the chip to start from the correct date and time and count onwards from that point, but in the event of a power failure the date and time would have to be manually reprogrammed. To rectify these situations and allow for consistent timekeeping that is essential for a serious data logging system, various chips exist known as Real-Time Clocks (RTCs). These chips are specifically designed to keep track of time and account for variables such as leap years and number of days in a given month, using an integrated binary-coded decimal clock and calendar. In the event of power loss, the chip often uses a backup battery with a lifetime of several years. We will discuss how these chips may be interfaced with our data logging system, and what IC architecture or configuration is easily compatible with the use of this chip.

### **4.1.9.1 Texas Instruments® MSP430™ Series**

The MSP430 was presented to us in a Texas Instruments® seminar, with a wide array of microcontrollers in their ‘Value Line’ which allow for much flexibility of specifications, offering a wide variety of flash and SRAM memory sizes, form factors, ADCs, and pin sizes. All chips from their Value Line have a clock speed of 16 MHz and boast an ultra-low power draw. The chip provided to us at the presentation was the MSP430G2553, which has a 16 kB flash memory size, 8 10-bit ADC channels, and 24 I/O pins. The MCU can operate at a supply voltage of up to 3.6 Volts. Also given to us was an MSP430 development board known as the ‘MSP430 Launchpad’ which supports their proprietary IDE, Code Composer Studio. The software is free and can utilize the C/C++ programming language, but it is only a limited trial version which has a code size limitation of 16 kB – this obviously doesn’t cause problems in this case.

Being that the microcontroller and development board were obtained at no cost to us whatsoever, the MSP430 is an attractive choice indeed. However, given the desired compatibility with an external storage device and the memory overhead this requires, the 16 kB internal flash memory may not leave enough headroom for other functions after the necessary software libraries are imported. However, if a USB interface was to be used, this microcontroller system may be what we’re looking for.

### **4.1.9.2 Microchip® PIC18 Series**

Another potential line of microcontroller that interests us is the Microchip® PIC18 line of enhanced performance 8-bit microcontrollers. The advantage of using a PIC18 MCU is its compatibility with C/C++ code and optimization for a C Compiler, as well as a reduced instruction set architecture. Their website has an exhaustive documentation, including a helpful amount of tutorials and workshops that help familiarize the user with the PIC18 instruction set and the software used. What’s also appealing is the IDE used – the MPLAB® IDE is a free development platform provided by Microchip® that fully supports C and is optimized for their proprietary C Compilers which unfortunately must be purchased. An evaluation version is available, however. The PIC18F45K22 MCU in their PIC18F series seems a smart choice, as it has 32 kB of programmable flash memory, a max CPU frequency of 64 MHz, 1.5 kB of internal RAM, an ADC with 28 10-bit channels, and an operating voltage up to 5.5 Volts. The package has a large pin size of 40 pins and 24 input/35 output lines. Despite this relative strength compared to our other choices, the chip manages to operate at an extremely low power draw utilizing power-saving technology when the chip is idle.

The chip itself is extremely cheap, weighing in at under just \$5. However, a complete code development platform is also available from Microchip® at a significantly higher cost – the PICkit 3 Debug Express is a development board that features the PIC18F45K20 microcontroller (identical to the 45K22 in many ways), a 44-pin demo board, and a CD that includes a vast amount of programming resources. These not only include 12 tutorials on assembly programming for the PIC18 and many other technical

aspects of the chip, but the MPLAB® IDE software with the fully featured version of the MPLAB® C Compiler. All of this comes to a cost of \$69.99, which is within our price range but a cheaper alternative possibly exists still.

### **4.1.9.3 Atmel® ATmegaXX8 Series**

The Atmel® line of chips seems to be the microcontroller of choice for most projects of this nature, and for good reason. Atmel® is similar to the Microchip® line of chips in that they both draw an appropriately low power level and utilize the RISC architecture. The ATmegaXX8 series prove to possess the parameters well within our specifications, with the ATmega168 and ATmega328 being the MCUs of choice. By all accounts the 328 is identical to the 168, having an 8-bit AVR CPU, a max clock speed of 20 MHz, pin size of 32, 23 I/O pins, an 8-channel, 10-bit ADC, and an operating voltage of 1.8 to 5.5 V. However, the 328 has a doubled memory size over the 168; with 32 kB of programmable flash memory over the 16 kB on the mega168, 2 kB of SRAM over the 168's 1 kB, and 1 kB of EEPROM over the 168's 0.5 kB. This will obviously prove more advantageous for our aims in data logging, as more code space is always welcome when we attempt to interface with a mass-storage device. Atmel® supports its AVR-based chips with AVR Studio® 5, an IDE that allows the coding of assembler and C/C++ projects within any Windows platform. The inclusion of an integrated C Compiler is also quite useful, and as far as we can tell the software is free and fully featured without any reduced-feature evaluation version.

As for a development board that supports the ATmega, an interesting opportunity has presented itself. The ATmega328 chip is the central component in a microcontroller platform manufactured by a company named Arduino. The Arduino Duemilanove is a microcontroller development board that is fully supported by open source software and even hardware, in that the schematics for the boards are published freely under a Creative Commons license and are free to be modified by the user as he wishes. Arduino uses their own IDE and programming language for developing code on the board, which claims to be simple to learn and use – not to mention free. The AVR/C coding language is even an alternative to this if the user prefers, as it is possible to simply use the standard AVR Studio® IDE to develop for the board. As for the board itself, its operating voltage is 5 V and can support input voltages upwards of 7 V. Only 14 digital I/O pins are available, but for our purposes this is quite sufficient. The current asking price for the Duemilanove is around \$20, and the chip seems to have developed a reputation among its users as an outstanding board for sensor and controller applications.

### **Microcontroller Summary**

While the MSP430 has an unbeatable price point of next-to-nothing cost wise for both the development board, the chip proper, and the proprietary software (of which the full version must be purchased), its data and tolerance considerations make it hard to recommend for our design. Likewise, the PIC18F microcontroller demonstrates powerful technical specifications, but the price premium that is to be paid in order to gain access to their fully-featured software package – which is upwards of \$70 – is a large factor in our

deciding against it. The microcontroller that will end up being both the most balanced chip specification-wise and the most convenient in terms of price, availability, and ease of use is the ATmega328 chip. This package, incorporated into the incredibly useful and scalable Arduino Duemilanove board and IDE, will make developing and programming a proper data logging system for the Intellaturbine a considerably less daunting prospect. At a price point of just around \$20, it is no doubt our development platform of choice.

### 4.1.9.4 Arduino Duemilanove

While the Arduino platform appears robust enough, on its own it does not meet our data acquisition needs. However, an enterprising engineer may find a possibility to expand upon the design with a readily available solution. Usually for boards that require an extended feature set a similar PCB ‘shield’ is mounted on top of the original board and the appropriate pins are wired together and soldered. We have discovered a data logging shield manufactured by Adafruit Industries that would introduce several key components into our data logging paradigm, including an interface for an SD memory card, a real-time clock chip for recording time stamps, preassembled C++ libraries that are available to operate these systems, and a large prototyping area that is suitable for incoming sensor signals. The hardware does not come assembled, however – some skill in soldering will be required to properly link these components together so that the microcontroller may make use of this new data logging capability. So, assuming that we utilize these components, we will have a data logging structure something like Figure 16:

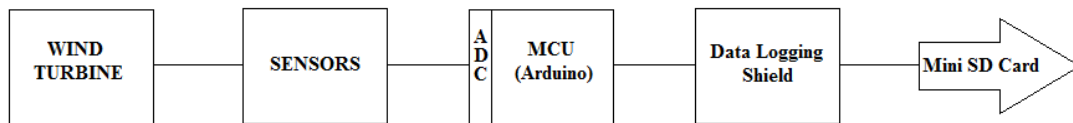
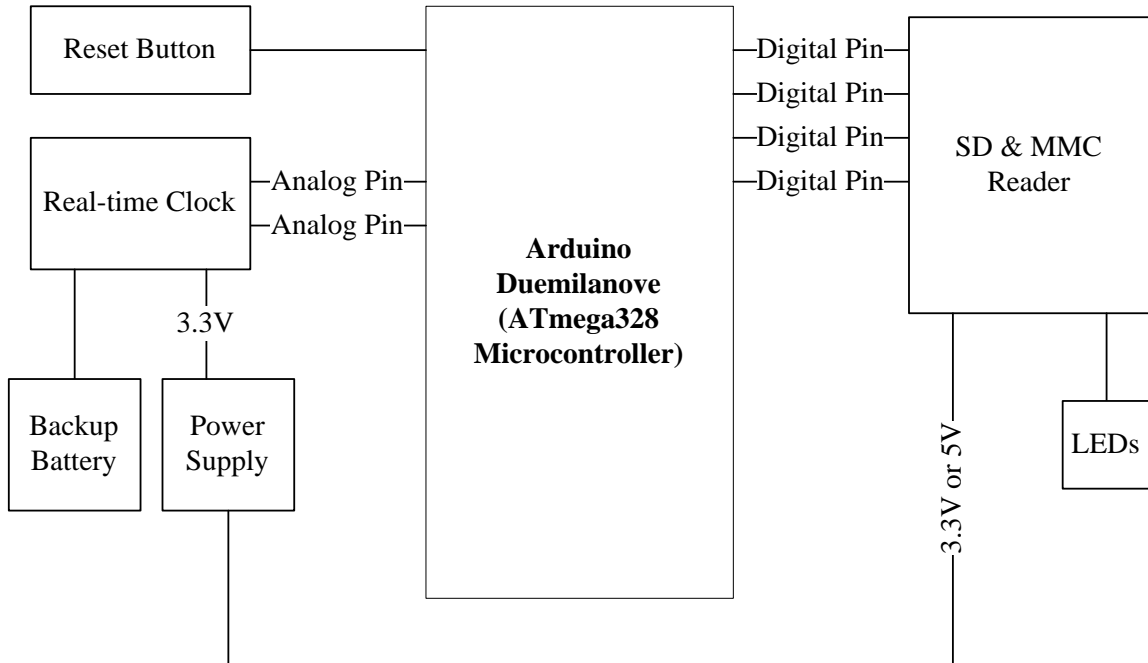

**Figure 16: Arduino Data Logging Subsystem Block Diagram**

As the Arduino Duemilanove will have the ATmega328 processor installed, the memory and code space implications of accommodating the required libraries and interfacing with the FAT16/32 file system used on most SD cards are not as unattainable, so there is plenty of room to breathe as far as freedom of code space is concerned (provided the Arduino board is the model that includes the ATmega328 processor). For the issue of price, the Adafruit Data Logging Shield can be purchased for \$19.50 off their website.

Put simply, the components introduced by the data logging shield will require 2 analog input pins for the real-time clock and 4 digital input pins for the SD card interface and power supply. On the Arduino, this leaves only 4 analog input pins (suitable for the 4 analog sensor signals we will be using) and 9 digital input pins. As the SD card will require a larger amount of power for its write operations than what the Arduino can provide, an additional power supply (rated 3.3V @ 250 mA) is included on the data logging shield that may provide the 5V  $V_{cc}$  to the SD & MMC reader as the device requires it. Finally, one red and one green LED are featured on the board to indicate when the SD device is being written to. Helpfully, the Eagle schematic for connecting these

two components was provided for reference on the Adafruit Industries website and a rough sketch will follow in Figure 17. This will show what features the Adafruitdata logging shield adds to the Arduino functionality.



**Figure 17: Interface between Arduino & Data Logging Shield**

It should be noted that this particular data logging shield is not the only option available to us. Various other devices are up for grabs that sport varying features, but common to each of them is the SD card slot and the capability to connect this peripheral to the Arduino host device in a much similar fashion as outlined in Figure 3. Some of these choices may even incorporate an additional microcontroller solely dedicated to logging data, which – if truly necessary – can ease the load on our main microcontroller which must handle not only the LCD display aspect of the design, but the rotational control system as well. What we desire in our design is a built-in real-time clock that can keep good time; however, if the dedicated data logging device features another microcontroller, it can afford us some additional I/O pins for the ADC.

Some dedicated data logging solutions include:

- The OpenLog by Sparkfun® Electronics. The device has an extremely small form factor and features an additional ATmega328 microcontroller to log a greater amount of data without interfering with other important Intellaturbine functions. The device also features built-in firmware utilizing a library of functions that help the 328 interface with a microSD card slot. Only the exceedingly small microSD card is supported however, which may not be as widely supported.

- The Logomatic also by Sparkfun® includes another dedicated processor as well – the ARM7 LPC2148. It includes a USB input that can be connected to a PC and from there the SD card can be directly accessed. This is quite useful for design and testing/development purposes, but for practical use a computer would have to be in close proximity to the Intellaturbine to take SD card data. Can take full-sized SDs. Also features an integrated real-time clock like the Adafruit shield.
- uDrive or ‘MicroDrive’, from 4D Systems is a well-documented data logger with a special microcontroller: The GOLDELOX-DOS chip. It has its own specific command list that allows for more advanced features such as the ability to read and write from specific file locations and ‘Auto-baud’, which detects the speed of the host device and adjusts its own internal baud rate to match it. The device contains a microSD slot. Given our relative lack of expertise with data logging devices, the uDrive’s advanced feature set isn’t quite suitable for our application.

## 4.1.10 Wind Sensors

The wind direction sensor is an integral part of the rotational control system of the Intella-Turbine. It will measure the wind direction as an input and give a voltage that’s proportional to the direction of the wind. The wind sensor will be mounted on the turbine’s nacelle. The Model 020C Wind Direction Sensor provides most of the requirements we need for our system. The table below, Table 6 provides the essential specifications of the wind sensor.

Maximum Operating Range	0 - 125 mph
Starting Speed	0.5 mph
Calibrated Range	0 - 100 mph
Accuracy	+/- 1 % (0.15 mph)
Temp Range	-50°C to 65°C
Power Requirements	12 VDC at 10 mA
Output Signal	11 Volt (pulse equivalent to speed)
Output Impedance	100 Ω
Weight	1.5 lbs

**Performance Characteristics  
Model 010C Wind Speed Sensor**

### Table 6: Wind Speed Sensor Characteristics

The wind speed sensor is another integral part of the rotational control system. Since the Intella-Turbine has a maximum operational wind speed, it is desired that the wind turbine never exceed its mechanic limit to prevent damage to the structural design. The purpose of the wind speed sensor is to monitor wind speed and if the wind speed exceeds the maximum allowable speed and the turbine fan is at its maximum RMP, then the rotational control system will kick in and position the turbine blades tangential to the

wind direction to slow it down. The table below provides all the specifications of the wind speed sensor.

A 3-cup rotating magnetic reed switch anemometer is easy enough to find, but if the sensors for wind speed and direction were to be combined into one semi-affordable package it would most likely make the Davis Instruments Model 7911 Anemometer. This unit can measure a range of wind speeds from 2 to 150 mph, with a rated accuracy of +/- 2 mph and 1 mph resolution. The advantages of such a simple assembly are obvious, and upon attempting to find the two components to purchase separately they were at a significant price premium over the Davis 7911. For reference, another wind speed sensor, the Inspeed Vortex Anemometer, is \$55 on its own and the 7911 is \$130.

Given that the Davis Instruments 7911 performs the functions of both a wind speed and wind direction sensor, it should come to no surprise that this unit was chosen for this purpose as well. The Davis 7911 wind direction sensor is a Wind Vane with a potentiometer that may either rotate 0 to 360 degrees (+/- 7 degree accuracy and 1 degree resolution) corresponding to 0 to 20 kilo-Ohms, or rotate between 16 fixed compass points with a 22.5 degree resolution between the points. A comparable wind direction sensing system, the Inspeed E-VANE, is \$130 on its own which is as much as the combined Davis sensor. But, this system utilizes a sealed magnetic Hall Effect sensor for even greater precision – precision that will not have any bearing on the overall design let alone for such a high price point.

For purposes of data logging, it may prove simpler to poll the wind speed and wind direction simultaneously, such that each time the anemometer completes a rotation and sends its pulse, the weather vane will send its signal as well. For a data logging interval, the number of pulses may be counted over the interval period, adjusted by the anemometer's calibration factor (rather, the wind speed that corresponds to a 1 Hz pulse frequency), then calculates the average wind speed. Where  $K$  is the calibration factor of the anemometer in units of mph/Hz,  $t$  is the data logging interval in seconds, and  $n$  is the number of pulses recorded over this period:

$$\text{Logged Wind Speed (mph)} = K \cdot \frac{n}{t}$$

For wind direction, perhaps a similar averaging formula may be used on the angles recorded by the sensor, but in a way such that the prevailing winds are detected rather than simply a statistically meaningless collection of gusts over a long period of time. Let's say the formula is: for the last 10 pulses the wind direction angles are averaged and recorded. Where  $\theta$  is the direction angle and  $n$  is the pulse at that point in time:

$$\text{Logged Wind Direction (Degrees)} = \frac{\sum_{n=-10}^0 \theta(n)}{10}$$

## 4.1.11 Voltage/Current Sensors

In order for Intellaturbine to monitor its own performance, current and voltage sensors must be hooked up to measure these variables against wind speed and determine whether the design is reaching the efficiency it should be. While it may be easy to measure current and voltage with common Electrical Engineering equipment, the LCD display and data logging subsystems rely on a very specific voltage signal in order that it does not damage the system with values that are beyond the devices' standard operating limits.

An analog voltage signal will not get far within a microcontroller without a built-in analog-to-digital converter; luckily all of our choices in MCU would accommodate this. The ADC will sample the incoming analog voltage signal at discrete time periods and voltage levels, often producing a histogram-like effect. Depending on the bit resolution and sampling rate of the ADC being employed in the design, we may get a more or less faithful digital reproduction of the original signal.

To measure the present battery voltage and relay this information into the processor, some simple procedures can be followed. To scale down the often very high voltage levels in the battery without affecting the integrity of the voltage signal – all the while being compatible with our chosen microcontroller – a voltage divider circuit is usually the best choice for reducing the incoming voltage signal and reaching safe input levels.

Measuring the current produced by the wind generator gives us the opposite issue; the proportional voltage signal that is often produced by the special low-Ohm shunt resistor is much too small for the microprocessor to understand or make sense of. Luckily various solutions are available in the realm of high-side current sensing. One may use a simple differential amplifier in tandem with several precision-configured resistors to produce the desired proportional output voltage from the shunt resistor, be it with traditional circuitry or discrete IC components. Typically these circuits introduce problems such as a high resistance difference between the two inputs that must be carefully balanced and matched. The other method of high-side current sensing attempts to simplify the process by integrating all the functions required to take the current measurement, removing the need for interacting with the ground plane and producing an externally adjustable output current proportional to the sense voltage across the shunt resistor. Some devices we have researched that are suitable for our design are the MAX4172 High-side Current-Sense amplifier by Maxim Products and the ZXCT1009 High-side Current Monitor by Diodes Incorporated. Once an output current is produced, it can then be tailored into an appropriate voltage signal to be accepted by the microcontroller via an additional limiting resistor. The MAX4172 boasts a higher upper-limit supply voltage of 32 V and a higher max output current of 1.75 mA, whereas the ZXCT1009 claims a higher bandwidth of 2 MHz over the MAX's 800 kHz (while having a limiting supply voltage of 20 V and output current ~1.0 mA). These methods are but the first step in conditioning our current signal, however. An active filter is also desired.

An active filter is often the term used for a frequency-limiting filter such as a low-pass or band-pass filter and an operational amplifier integrated into a single circuit. For our case, the passive RC components of a low-pass filter will not only reduce unwanted external

noise from elsewhere in the design, but will ease the load on the microcontroller such that it can poll the incoming analog signal at a lower, more comfortable frequency. The passive filter will wire into at least one op-amp, where factors such as the aforementioned current gain may be addressed and controlled accordingly. A suitable op-amp for our design based on research is the Texas Instruments® LM6484, which is a DIP of four op-amps that may be used in a rail-to-rail configuration for simple second order filtering with or without gain, depending on the resistor values used. For the current sensor some amount of gain is desired for greater resolution in the ADC. An example schematic of the op-amp configuration that will result in a second order low-pass filter is in Figure 18:

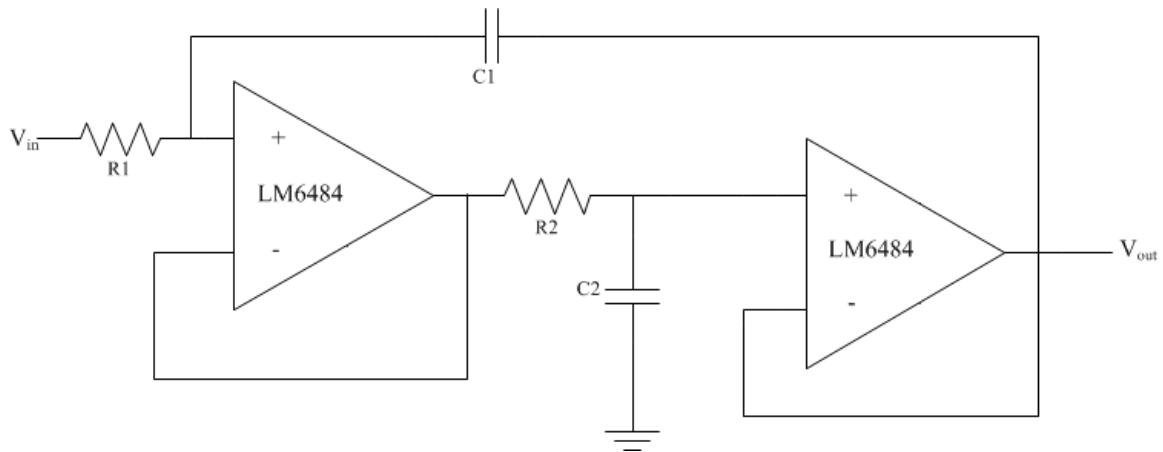

**Figure 18: Anti-Aliasing Filter using two LMC6484 op amps  
(Derived from Texas Instruments® LM6484 Datasheet)**

This configuration will result in a low-pass filtered signal with unity gain. The resistor-capacitor combination before each amplifier is of identical RC values, with the relations:

$$R_1 = R_2, C_1 = C_2, f = \frac{1}{2\pi R_1 C_1}$$

While the current signal needs an active gain for the microprocessor to convert it and take accurate measurements, the ZXCT1009 has a built-in op-amp with a gain of 100 as part of its internal circuitry. The low input current of the LM6484 is suitable for the undoubtedly low current signals that will be feeding to the filter and thereby to the ADC.

In the case of voltage sensing, it is not necessary to amplify the signal. Our goal with the voltage-logging aspect of the display and data logger is to poll the present voltage within the battery system. However, use of the active filter is still desired, as the voltage signal will no doubt experience no small amount of aliasing. In this case, however, we may use our LM6484 configuration with a unity gain for filtering without amplification. The current and voltage sensing paradigms in our design are outlined by Figure 19.

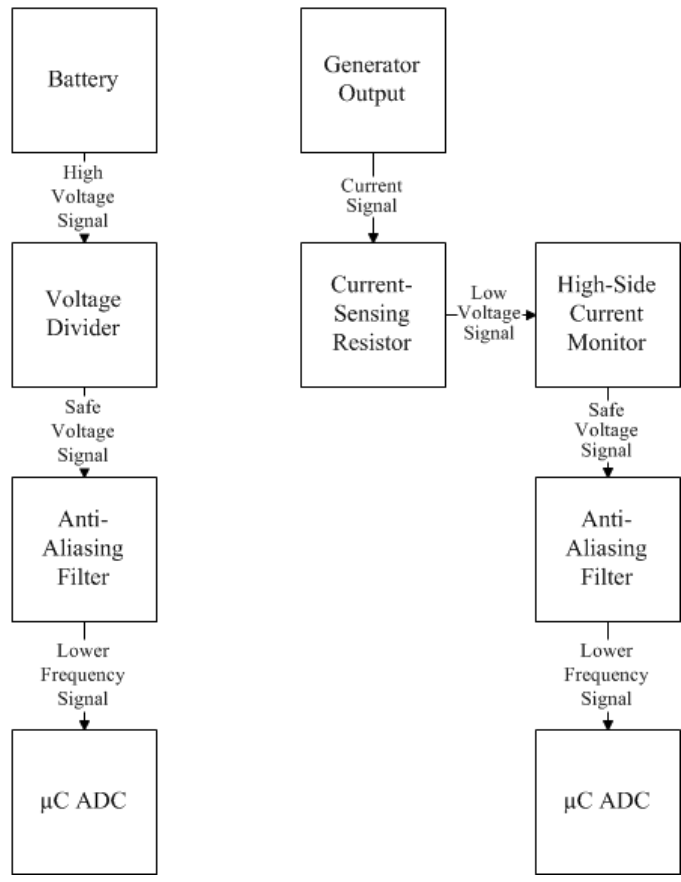

**Figure 19: Current and Voltage Sensing Process**

### 4.1.12 Servomotor versus Stepper Motor

To achieve maximum power generation from the wind turbine, a rotational control system will be added to the project design. The primary purpose of the rotational control system is to track the direction and speed of the wind and position the turbine’s blades in the direction of the wind for maximum power generation. The secondary purpose of the rotational control system is to monitor the wind speed to prevent overspinning of the turbine rotor. If the maximum RPM that the wind turbine can handle without any structural damage is exceeded, the rotational system will position the turbine’s blades in the opposite direction of wind speed to reduce the efficiency of wind to rotate the turbine’s blades. To achieve these requirements the usage of a motor will be needed. We are debating whether to use a servomotor or a stepper motor to accomplish our design objectives so the proper research will be done before making a decision. The direct current (DC) motor is one of the first machines devised to convert electrical energy to mechanical power. Its origin can be traced to machines conceived and tested by Michael Faraday, the experimenter who formulated the fundamental concepts of electromagnetism. These concepts basically state that if a conductor, or wire, carrying current is placed in a magnetic field; a force will act upon it. The magnitude of this force is a function of the strength of the magnetic field, the amount of current passing through

the conductor and the orientation of the magnet and conductor. The direction in which this force will act is dependent on the direction of current and direction of the magnetic field. Electric motor design is based on the placement of conductors (wires) in a magnetic field. A winding has many conductors, or turns of wire, and the contribution of each individual turn add to the intensity of the interaction. The force developed from a winding is dependent on the current passing through the winding and the magnetic field strength. If more current is passed through the winding, then more force (torque) is obtained. In effect, two magnetic fields interacting cause movement: the magnetic field from the rotor and the magnetic field from the stators attract each other. This becomes the basis of both AC and DC motor design. Since the Intella-Turbine is a relatively large wind turbine, the selected motor must have high torque, be energy efficient and operate at relatively low noise.

### **4.1.12.1 Stepper Motor**

Stepper motors are electromechanical actuators that convert digital inputs to analog motion. This is possible through the motor's controller electronics. There are various types of stepper motors such as solenoid activated, variable reluctance, permanent magnet and synchronous inductor. Independent of stepper type, all are devices that index in fixed angular increments when energized in a programmed manner. Stepper motors' normal operation consists of discrete angular motions of uniform magnitude rather than continuous motion. A stepper motor is particularly well suited to applications where the controller signals appear as pulse trains. One pulse causes the motor to increment one angle of motion. This is repeated for one pulse. Most stepper motors are used in an open loop system configuration, which can result in oscillations. To overcome this, either complex circuits or feedback is employed, thus resulting in a closed loop system. Stepper motors are, however, limited to about one horsepower and 2000 rpm, therefore limiting them in many applications. Since in our application the rpm of the motor is not as important as the motor's torque, a stepper motor for our applications would not be suitable.

### **4.1.12.2 Servomotor**

A servomotor is a DC motor, designed specifically to be used in a closed-loop control system. Since the servomotor will be controlled by a microcontroller using a PWM wave generator with limited voltage and current drive capability, a power amplifier will be used to meet the servomotor's current and voltage requirement. The function, or task, of a servomotor can be described as a command signal that is issued from the system microcontroller and comes into the servo's positioning controller. The positioning controller is the device that stores information about various jobs or tasks. It has been programmed to activate the motor's load, for example a change in speed or position. The signal then passes into the servo control or amplifier section. The servo control takes this low power level signal and increases, or amplifies the power up to the appropriate levels to actually result in movement of the servo motor's load. These low power level signals

must be amplified: Higher voltage levels are needed to rotate the servomotor at appropriate higher speeds and higher current levels are required to provide torque to move heavier loads. This power is supplied to the servo control amplifier from the power supply that in our case would be a 24-volt battery. It also supplies any low level voltage required for operation of integrated circuits. As power is applied onto the servomotor, the load begins to move and speed or position changes accordingly. The speed of the motor's shaft or the angle of rotation is measured by a tachometer, resolver or encoder, which in turn provides a signal that is sent back to the controller. This feedback signal is informing the positioning controller whether the motor is doing the proper job. The positioning controller looks at this feedback signal and determines if the load is being moved properly by the servo motor; and, if not, then the controller makes appropriate corrections. For example, assume the command signal was to drive the load to an angle of 45 degrees. For some reason after that command is performed the position of the load is not at 45 degrees but is at 35 degrees. The feedback signal will inform the controller that the position is 35 degrees. The controller then compares the command signal (desired position) of 45 degrees and the feedback signal (actual signal) of 35 degrees and notes an error. The controller then outputs a signal to apply more voltage onto the servomotor until the desired position equals the actual position of the motor shaft, meaning the error signal between the desired position and actual position is zero. The Quantum NEMA 23 servomotor is electromechanically optimized for high output power, high torque density, and low cogging torque. The high performance and power density ratio of the NEMA 23 servomotor allows a smaller size motor to be used in many applications, saving space and weight. Some of the benefits of the NEMA 23 Servomotor are rated stall torque from 51 oz-in up to 185 oz-in. Computer optimized design for maximum power and torque density ensures the most compact and efficient design possible. This servomotor has encoder and resolver feedback options for compatibility with virtually all servo drives and motion controllers.

### **4.1.13 Control Methods**

The control of physical system with a digital computer or microcontroller is becoming more and more common. Examples of electromechanical servomechanisms exist in aircraft, automobiles, mass-transit vehicles and many more applications. Furthermore, many new digital control applications are being stimulated by microprocessor technology including control of various aspects of automobiles and households appliances. Among the advantages of digital approaches for control are the increased flexibility of the control programs and decision-making or logic capability of digital systems, which can be combined with the dynamic control function to meet other system requirements. In addition, one hardware design can be used with many different software variations on a broad range of products, thus simplifying and reducing the design time. As with any engineering design method, design of control systems requires many computations that are greatly facilitated by a good library of well-documented computer programs. In designing practical digital control systems, and especially in iterating through the methods many times to meet essential specifications, and interactive computer-aided control system design (CACSD) package with simple access to plotting graphics is

crucial. Many commercial control systems CACSD packages are available which satisfy that need, Matlab and matrix being two very popular ones. Much of the discussion in the book assumes that a designer has access to one of the CACSD products. Specific Matlab routines that can be used for performing calculations are indicated throughout the text and in some cases the full Matlab command sequence is shown. All the graphical figures were developed using Matlab and the files that created them are contained in the Digital Control Toolbox that is available on the Web at no charge. These figure files should be helpful in understanding the specifics on how to do a calculation and are an important augmentation to the overall design. The Matlab statements in the text are valid for Matlab v5 and the Control System Toolbox v4.

The use of digital logic or digital computers to calculate a control action for a continuous dynamic system introduces the fundamental operation of sampling. Samples are taken from the continuous physical signals such as position; velocity or temperature and these samples are used in the computer to calculate the controls to be applied. Systems where discrete signals appear in some places and continuous signals occur in other parts are called sampled-data-systems because continuous data are sampled before being used. In many ways the analysis of a purely continuous system or of a purely discrete system is simpler than is that of sampled-data systems like the rotational control system used by the Intela-Turbine. The analysis of linear, time-invariant continuous system can be done with the z-transform alone. If one is willing to restrict attention to only the samples of all the signals in a digital control one can do much useful analysis and design on the system as a purely discrete system using the z-transform. However the physical reality is that the computer operations are on discrete signals while the plant signals are in the continuous world and in order to consider the behavior of the plant between sampling instants, it is necessary to consider both the discrete actions of the computer and the continuous response of the plant. Thus the role of sampling and the conversion from continuous to discrete and back from discrete to continuous are very important to the understanding of the complete response of the digital control system, and we must study the process of sampling and how to make mathematical models of analog-to-digital conversion and digital-to-analog conversion. This analysis requires the usage of the Fourier transform.

The control of a servomotor will employ some sort of power regulation and compensation for stability purposes. The power regulator or amplifier regulates the amount of power being applied onto the servomotor, and moving the load. One type of power regulation is the SCR (silicon controller rectifier), which will be connected to and AC power supply. This type of device is usually employed where large amounts of power must be regulated, motor inductance is relatively high and accuracy in speed is not critical. Power out of the SCR, which is available to run the motor, comes in discrete digital pulses. At low speeds a continuous stream of high frequency pulses is required to maintain speed. If an increase in speed is desired, the SCR must be turned on to apply large pulses of instant power, and when lower speeds are desired, power is removed and a gradual coasting down in speed occurs. Since our power supply would be from a 24 volts battery, the SCR method would not be a good fit for our design. If smoother speed is desired, an electronic network may be introduced. By inserting a phase-lag network, the response of the control is slowed so that a large instant power pulse will not suddenly be

applied. Filtering action of the lag network gives the motor a sluggish response to a sudden change in load or speed command changes. This sluggish response is not important in applications with steady loads or extremely large inertia. But for wide range, high performance systems, in which rapid response is important, it becomes extremely desirable to minimize sluggish reaction since a rapid change to speed commands are desirable. Transistors may also be employed to regulate the amount of power applied onto a servomotor. With the transistor, there are several techniques or design methodology, used to turn transistors on and of. The technique or mode of operation may be linear, pulse width modulated (PWM) or pulse frequency modulated (PFM). The linear mode uses transistors, which are activated, or turned on, all the time supplying the appropriate amount of power required. If the duty cycle of the signal applied to the servomotor is at 50 %, then half of the power goes to the servomotor. If the duty cycle is at 100 %, then all the power goes to the motor and it operates at full speed according to the supplied voltage. Thus for the linear type of control, power is delivered constantly, not in discrete pulses like the SCR control. Thus better speed stability and control is obtained. Another technique is using pulse width modulation (PWM). With a microcontroller generating a PWM wave, applying pulses of variable width to the servomotor regulates the power being delivered. In comparison with the SCR control, which applies large pulses of power, the PWM method applies discrete power pulses. The PWM pulses used to control most servomotors are show in Figure 20. PWM has the advantage in that the power loss in the transistor is small because the transistor is either fully on or fully off, therefore, power dissipation in the transistor is greatly reduced. The final technique researched for our design was the pulse frequency modulation (PFM). Pulse frequency modulation did not provide any real advantage over PWM so we decided not to consider PFM in our design.

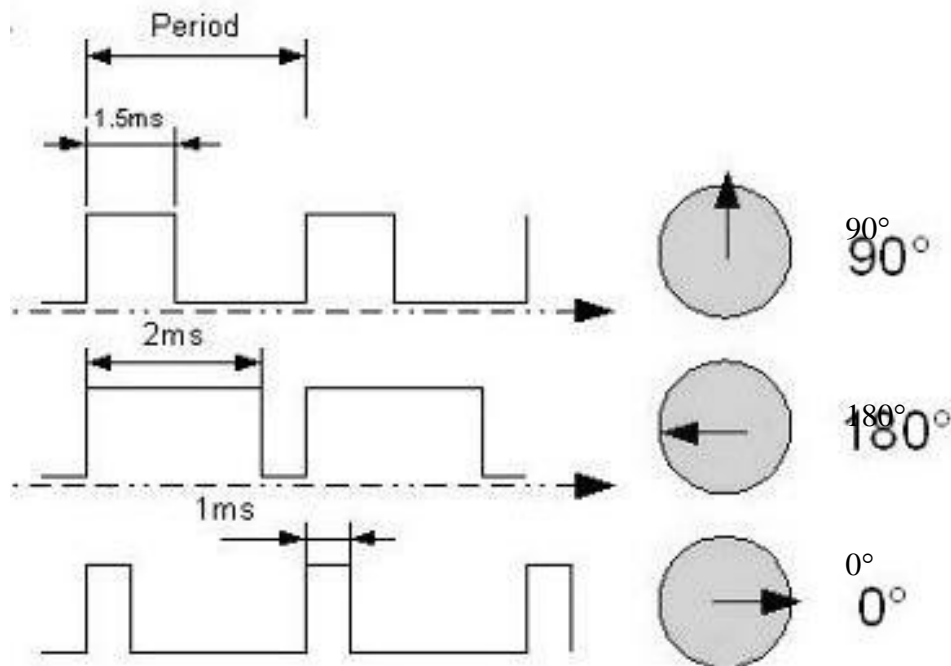

**Figure 20: Pulse train for angle rotation**

## 4.1.14 Compensator

A compensator is a controller meant to improve characteristics of the open-loop transfer function so that it can safely be used with feedback control. A P controller is a pure gain with no dynamic characteristics. This compensator is used in situations in which satisfactory and steady state responses can be obtained by simply setting a gain in the system, with no dynamic compensation required. A PI controller is used to improve the steady state response of the system. The transfer function of the PI controller is defined as

$$G_C(s) = \frac{K_p s + K_f}{s}$$

The PI controller has a pole at the origin and a zero at  $-K_i/K_p$ . Since the pole is nearer to the origin than to zero, the controller is phase lag, and it adds a negative angle to the angle criterion for stability purposes. As we see from the transfer function above, the controller has two independent parameters that need to be determined in the design process to meet the desired steady state conditions. Another type of controller is the PD controller. The transfer function of the PD controller is defined as follows.

$$G_C(s) = K_p + K_D s$$

As we can see from the transfer function above the PD controller introduces a single zero at  $-K_p/K_D$ , so the controller adds a positive angle to the angle criterion for stability purposes. The purpose of this controller is to improve the transient response of the system. The main drawback of the PD compensator is that the gain continues to increase as the frequency of the system increases, and the compensator will amplify any high frequency noise that's embedded in the system. One way of reducing this problem with high frequency noise is to add a pole to the transfer function. The final compensator that will be considered for our design is the PID controller. The PID controller is used in control systems in which improvements in both the transient response and steady state response are required. The transfer function of the PID controller is of the form

$$G_C(s) = K_p + \frac{K_i}{s} + K_D s$$

Thus from the transfer function we can see that the PID controller has two zeros and one pole. For our application, we want a compensator that could improve the transient characteristics of our system as well as the steady state response. The figure below shows how the compensator behaves with different parameter changes. In our design, we want our system to behave with minimum response overshoot and the smallest settling time possible.

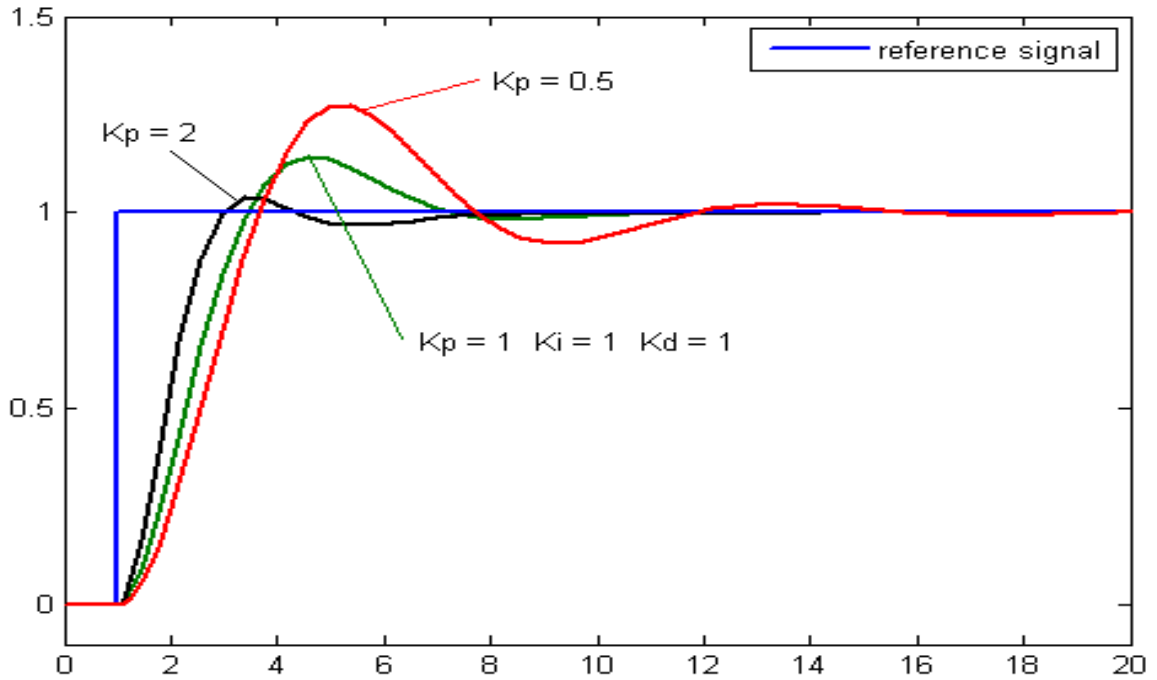

**Figure 21: Compensator response for different values of  $K_p$**   
(Permission Pending)

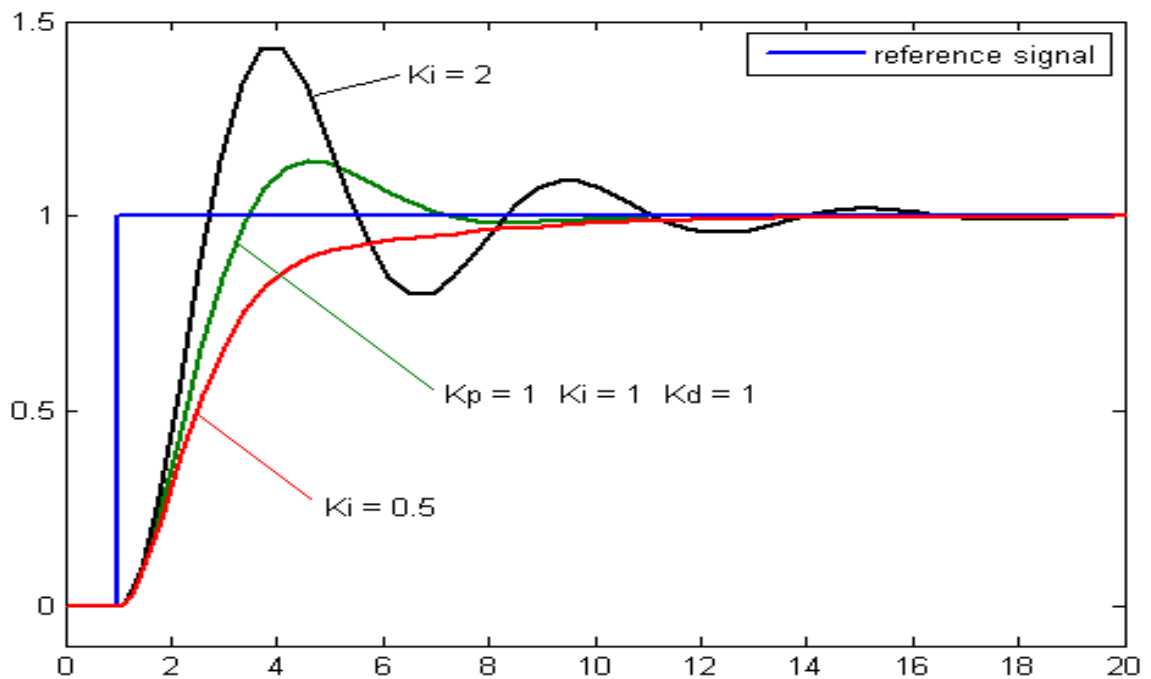

**Figure 22: Compensator response for different values of  $K_i$**   
(Permission Pending)

Figure 21 is the step response of the PID controller for various values of  $K_p$ . We can see that as the value of  $K_p$  increases the percent overshoot of the system decreases and as the value of  $K_p$  decreases the percent overshoot of the system increases drastically. We can also see from Figure 21 that as the value of  $K_p$  increases the rise time of the system gets smaller and as the value of  $K_p$  decreases the rise time of the system increases. From these results we can conclude that for our design to have a very rapid rise time (how fast the output reaches the input) the value of  $K_p$  in the rotational control system compensator must be as large as possible. Figure 22 is the step response of the PID controller for various values of  $K_i$ . We can see that as the value of  $K_i$  increases the overshoot of the system response increase. As the value of  $K_i$  decrease the overshoot of the system decreases. The settling time of the system response is of primary importance because we want the output to reach a stable condition within a few seconds after the input is applied. From figure YY we can see that as the value of  $K_i$  increases the settling time of the system response increases and as the value of  $K_i$  decreases the settling time decreases accordingly. For optimal performance of the system's compensator the value of  $K_i$  should be 0.707. Sometimes the final design of the compensator will oscillate and be unstable after you digitalize the compensator to be used in a digital computer even if the system is stable operating in analog mode, that's why it is very important to use the best digital approximation method to come up with a stable digital compensator.

## 4.2 Software

### 4.2.1 Data Logging

The software routines to be programmed into the microcontroller for the purposes of logging data that can be written to the SD card as well as be saved into a format that is legible by the user require no small amount of considerations on our part. For one, the file format of the SD card is important in deciding what the user will see after the relevant data is written to the device via the microcontroller then read by the PC. Without proper formatting the data will simply be interpreted by most modern operating systems as 'RAW' data, and no data logged on the card would be reachable at this point without the aid of a software-level program to retrieve it. However, when formatted with a FAT16/32 file system that can interact with most contemporary personal computers, the SD card can be read as well as organized into various folders as the user wishes.

The FAT file system suits our needs for interfacing the SD card data with a PC to be read, but a comprehensive software library must be built to accommodate the structure of the FAT16 or 32, including functions that can buffer enough memory for faster reading and writing of data (often requiring a significant chunk of the programmable memory available on our microcontroller), a function that checks the raw data for errors upon adapting it for the new file system, and a function that can utilize and traverse different directories and involved file paths for a greater amount of organization of data. For this reason attempting to reconcile an AVR-based microcontroller such as the ATmega328 with an SD file system on the software level is often a rather involved project in itself.

As mentioned before, the library of functions for the necessary SD interfacing processes is available online and open source to be used in tandem with any 328-based Arduino board, complete with various utilities and examples to gain a better understanding of said processes. For the sake of time constraints and convenience, we have decided it best to simply use the library at <https://github.com/adafruit/SD> shared under the GNU General Public License v3, giving us the freedom to use and modify it. In any case, the programs and routines for collecting the various data values from the sensors and writing it to an SD card in the proper format are still to be designed by us.

The raw data from the microcontroller can be a string of characters within the code that contain all the relevant data as recorded by the sensors. To be capable of being exported into a spreadsheet program of the user's choice once it is written to the SD card, the data must be in a plain text file format and can follow one of two conventions:

1. A text file (i.e, a file with a .txt extension) that has the data values delimited by TAB characters, or one indent between each data value. This can then be exported to a spreadsheet program using the 'Open With' command in Windows and selecting the program desired.
2. Comma separated values file (.csv); identical to a traditional text file in many ways, but with a .csv file the values are delimited by commas rather than indents. This file type can often be opened directly with the user's desired spreadsheet software, but in some international conventions a comma represents a decimal, which would obviously pose a problem in that sense.

Note that these delimiting characters will separate cell columns only – to begin a new row in the spreadsheet, a new line character must be entered. Upon opening the appropriately formatted file with the spreadsheet program, the user may choose to utilize the chart/graph functionality often available to such software and plot or analyze the data at his or her leisure. Following is a diagram (Figure 23) that outlines levels of operation and the path of the data through which the sensor parameters pass.

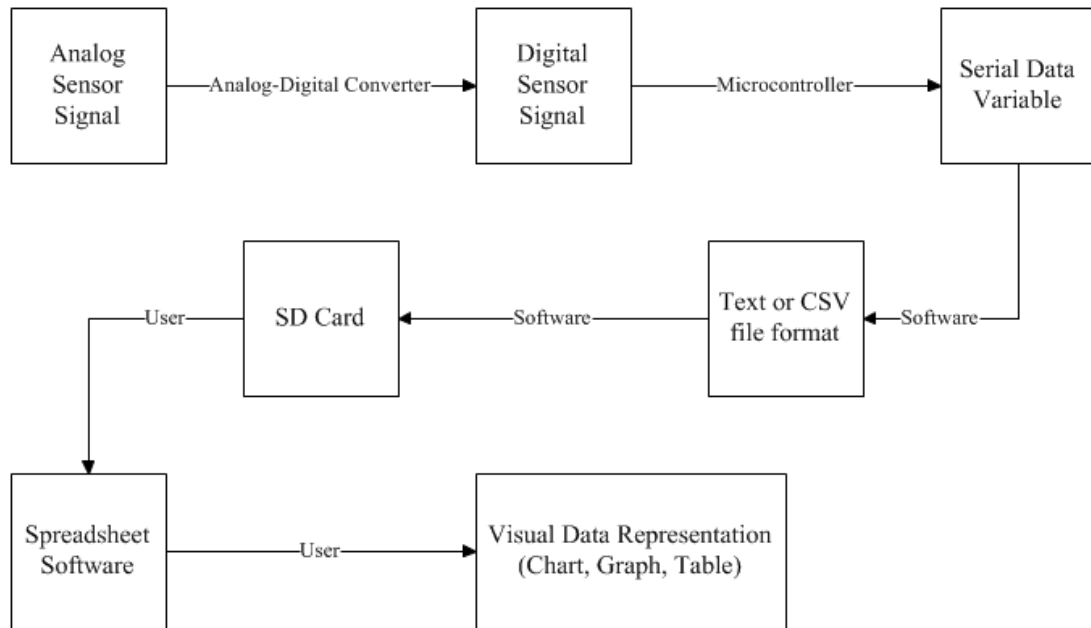

**Figure 23: The Data Logging Process**

Another consideration for the software aspect of the design is the IDE, or Integrated Development Environment we will be using to write our code for the data logging mechanism of Intellaturbine. The Arduino board presents us with several options for coding the device, each with its own advantages and disadvantages:

1. The IDE designed by the Arduino team, Arduino 1.0. This environment was programmed in Java and was specifically engineered to communicate effectively with the Arduino board and upload code to it. It features a built-in syntax error checker, compiler, and a serial monitor to display data being sent to or from the board. The default language used is based on the Processing/Wiring coding language, based on Java. However, the Arduino language is implemented in familiar C/C++ with a set of C/C++ functions that can be called from the code.
2. The default AVR Studio IDE by Atmel may also be used, in which it is also possible to program the board using either the C/C++ coding language or the default AVR assembly language. The compiler is not included with the software without spending some amount of money; however, some alternatives may be available. To be sure, the Arduino IDE is a better choice in this case because to appropriately link the Arduino libraries, further configuration is required.

## 4.2.2 Display

All software for the display will be written in high-level language, preferable C. We will be using the standard Atmel AVR Studio for Integrated Development Environment (IDE) for developing and debugging embedded Atmel AVR applications. The AVR Studio 5.1

IDE gives you a seamless and easy to use environment to write, build, and debug your C or C++ high-level language.

## 4.2.2.1 Routines

Hitachi HD44780 LCD controller is one of the most common dot matrix liquid crystal display (LCD) controllers available today. Hitachi developed the microcontroller specifically to drive alphanumeric LCD displays with a simple interface that could be connected to a general-purpose microcontroller or microprocessor. The device can display ASCII characters, Japanese Kana characters in four 20-character lines. The Hitachi HD44780 has two operating modes, and 8-bit mode and a 4-bit mode. The 8-bit mode is the standard mode but requires the use of twice as much I/O line than the 4-bit mode. The 4-bit mode is more complex but reduces the number of I/O data lines used. In applications where the number of I/O lines available is limited, this operating mode is more suitable. In our design we will implement the 4-bit operating mode to save I/O lines on the microcontroller. The table below, Table 7, describes the 4-bit write sequence commands and instructions of the LCD controller.

<b>4-Bit Write Sequence</b>
Make Sure EN = 0 or low
Set "R/S" to 0 for a command, or 1 for data
Put the High Byte of the data/command on D7-4
Set "EN" to 1 or high
Wait at least 450 ns
Clear "EN" to 0 or low
Wait 5ms for command writes, and 200us for data writes
Put the low byte of the data/command on D7-4
Wait at least 450ns
Clear "EN" to 0 or low
Wait 5ms for command writes, and 200us for data writes

**Table 7: LCD Display 4-Bit write Sequence**

The interface is either a 4-bit or 8-bit parallel bus that allows fast reading/writing of data to and from the LCD. This waveform will write an ASCII Byte out to the LCD's screen. The ASCII code to be displayed is eight bits long and is sent to the LCD either four or eight bits at a time. If 4-bit mode is used, two nibbles of data (First high four bits and then low four bits with an E Clock pulse with each nibble) are sent to complete a full eight-bit transfer. The E Clock is used to initiate the data transfer within the LCD. 8-bit mode is best used when speed is required in an application and at least ten I/O pins are

available. 4-bit mode requires a minimum of six bits. In 4-bit mode, only the top 4 data bits (DB4-7) are used. The R/S pin is used to select whether data or an instruction is being transferred between the microcontroller and the LCD. If the pin is high, then the byte at the current LCD Cursor Position can be read or written. If the pin is low, either an instruction is being sent to the LCD or the execution status of the last instruction is read back. Table 8 below lists all the commands for the Hitachi HD44780 LCD display.

R/S	R/W	D7	D6	D5	D4	D3	D2	D1	D0	Instruction/Description
0	0	0	0	0	0	0	0	0	1	Clear Display and Home the Cursor
0	0	0	0	0	0	0	0	1	*	Return Cursor and LCD to Home Position
0	0	0	0	0	0	0	1	ID	S	Set Cursor Move Direction
0	0	0	0	0	0	1	D	C	B	Enable Display/Cursor
0	0	0	0	0	1	SC	RL	*	*	Move Cursor/Shift Display
0	0	0	0	1	DL	N	F	*	*	Set Interface Length
0	0	0	1	A	A	A	A	A	A	Move Cursor into CGRAM
0	0	1	A	A	A	A	A	A	A	Move Cursor to Display
0	1	BF	*	*	*	*	*	*	*	Poll the "Busy Flag"
1	0	D	D	D	D	D	D	D	D	Write a Character to the Display at the Current Cursor Position
1	1	D	D	D	D	D	D	D	D	Read the Character on the Display at the Current Cursor Position

**Table 8: LCD Command Set**

**ID** – Increment the cursor after each byte is written

**S** – Shift display when byte written to display

**D** – Turn display on (1) off (0)

**C** – Turn cursor on (1) off (0)

**B** – Cursor blink on (1) off (0)

**SC** – Display shift on (1) off (0)

**RL** – Direction of shift right (1) Left (0)

## 4.2.2.2 Variable Definitions

Table 9 contains the list of the most important functions to be used in the programming of the microcontroller to display all the measured parameters on the LCD display. This table also shows the function return type to be used or the acceptable values for the function. A description is also given discussing how the functions are to be used.

Function Name	Function return type	Description
<u>lcd_set_data_type</u>	Void	Tells the LCD controller data is going to be send
<u>lcd_set_command_type</u>	Void	Tells the LCD controller a command signal is being send
<u>Lcd_write_nibble</u>	Void	Gets the nibble of the characters ascii code to be written on the lcd
<u>Lcd_write_byte</u>	Void	Handles the bytes to be written on the LCD
<u>Lcd_clear_home</u>	Void	Clears the display and returns the cursor to the starting position
<u>Lcd_home</u>	Void	Sets the cursor at the starting position
<u>Lcd_write_data</u>	Void	Sends the data to be written on the LCD
<u>Lcd_write_string</u>	Void	Writes a string stored in flash memory
<u>Lcd_go_position</u>	Void	Move the cursor to the desired position
<u>Lcd_line_one</u>	Void	Line one of the LCD
<u>Lcd_line_two</u>	Void	Line two of the LCD
<u>Lcd_line_three</u>	Void	Line three of the LCD
<u>Lcd_line_four</u>	Void	Line four of the LCD
<u>Lcd_initialize</u>	Void	This function initializes the LCD for data writing
<u>Delay_time</u>	<u>int</u>	Delay time during writing characters

**Table 9: Display Function Definitions**

# 5 Design

## 5.1 Wind Turbine

To meet design specification (dictated by sponsor) Intellaturbine will need a wind turbine mechanism capable of producing 1 kW at 24 VDC. Our choice of turbine was limited as our sponsor basically decided which turbine he wanted to use. The team was however, allowed some leeway to research for a better more capable option. After extensive research it was agreed that our sponsor had made a good choice. The TLG-500 series of wind turbine capable of producing 500 watts at 24 VDC was our turbine of choice. With each turbine producing only 500 watts, two would be needed. Since this was our sponsor's requirement the cost of having to purchase two turbines was not an issue. In fact, this was an attractive option for the team as some redundancy could now be designed into the circuit. Meaning if one turbine was to fail, our complete design would not be rendered totally inoperable. Each TLG-500 will be acquired at a cost of \$785 and the team should have them in hand during the break between the two academic semesters.

At first glance the TLG-500 seems to be expensive when compared to other 500 watts rated turbines. However, the difference here is that the TLG-500 output is rated in real world and not instantaneous output. Another plus is that the TLG-500 comes under rated from its manufacturer; this is good news for the team because it means all our power requirements will be met. The following table illustrates the approximated watts and voltage produced by the turbine at different RPM's. The figures in Table 10 here were generated from the manufacturer's website.

TLG-500 Turbine		
Rotation Speed (RPM):	Approximated Watts Produced:	Approximated Volts Produced:
100	40	10
200	100	17
300	300	25
400	500	34
500	650	42
600	700	50

**Table 10: RPM vs. Watts and Voltage Produce by TLG-500**

The TLG-500 is a sturdy, robust unit weighing in at 28 pounds 4 ounces (without blades), making it more than twice the weight of other common turbines. The unit's low maintenance characteristics can be attributed to this robust design with oversized dual bearings. The unit's large aluminum alloy case has its windings close to the outside edge thus using the case as a huge heat sink. This robust design does come at a cost however, as special consideration will have to be made when installing the turbines. This is even

more crucial in our case as we will be mounting two turbines. The team has two choices: mount both turbines on a single shaft or on separate shafts. If separate shafts are used then twice the amount of wind maximizing equipment will have to be used hence increasing our budget. This will also lead to other issues as the wind maximizing equipment would now have to be synchronized. The team decided to mount both turbines on a single structure. This however meant that it would have to be strong enough to support both turbines with blades. The distance between the turbines is very critical here to ensure there is no overlap with the blades as this could lead to them touching or have a turbulence effect. Below in figure is a model drawn in AutoCAD of how the team plans to mount the two turbines. As can be seen from the diagram in Figure 24, there will be an important mechanical design factor ensuring the structure is capable of the task it will be charged with.

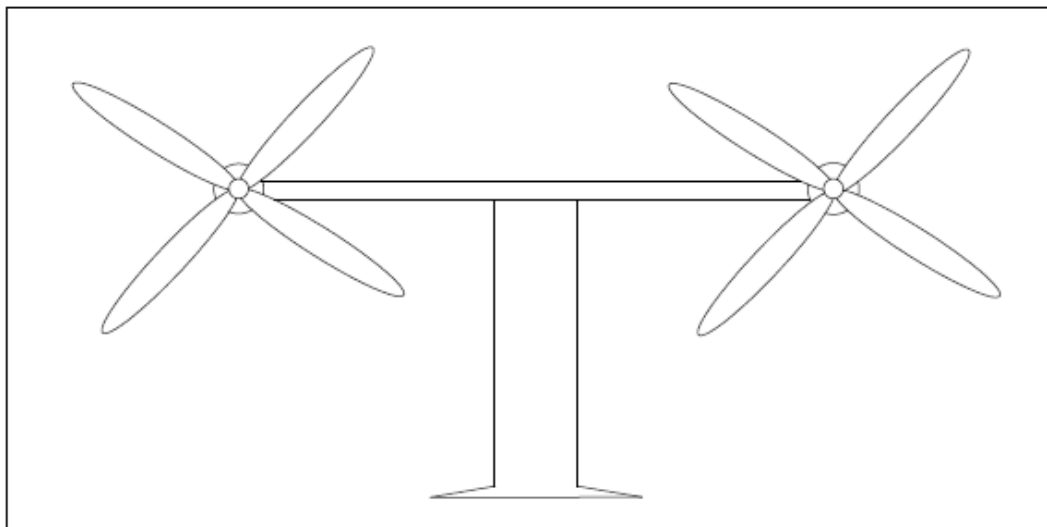

**Figure 24: Sketch of Turbine Structure**

## **5.2 Battery Bank**

Lead acid flooded batteries were chosen to be implemented as the battery bank. They were chosen because of their low maintenance cost and discharge rate among other characteristics. In this system there will be four 6V lead acid flooded batteries that will combine in series for a 24V battery bank. Each battery is rated at 520Ah at the 20Hr rate. A bulk charge will charge the battery bank to 25.68V, 2.58VPC, and the battery will then be disconnected. Although it is not in the design there is a possibility for an alternate power source for when there is no wind as shown in Figure 25.

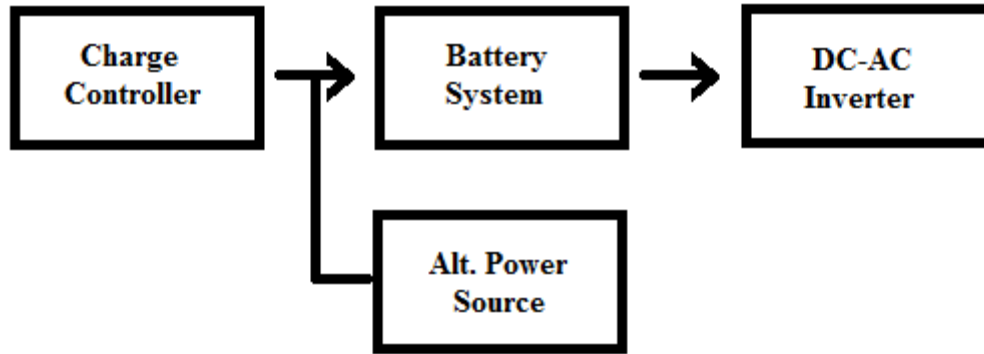

**Figure 25: Battery System Block Diagram**

This design monitors the voltage across the battery rather than the current going through it. To check battery status a comparator circuit will be implemented into the design. Monitoring the battery will be done with LEDs that light up as the battery is charged. The LM339 Quad Comparator will be used to illuminate four LEDs as the battery reaches full charge. A 5V reference will be used at each positive input. Each LED will light up at 25% charge intervals. At full charge the last LED will light up and the circuit will switch to the dummy load. When the battery charge drops and all LEDs are not lite the system will recharge the battery. The figure below is of a 12V system but can be modified for 24 volts. Figure 26 shows the schematic for our battery monitor.

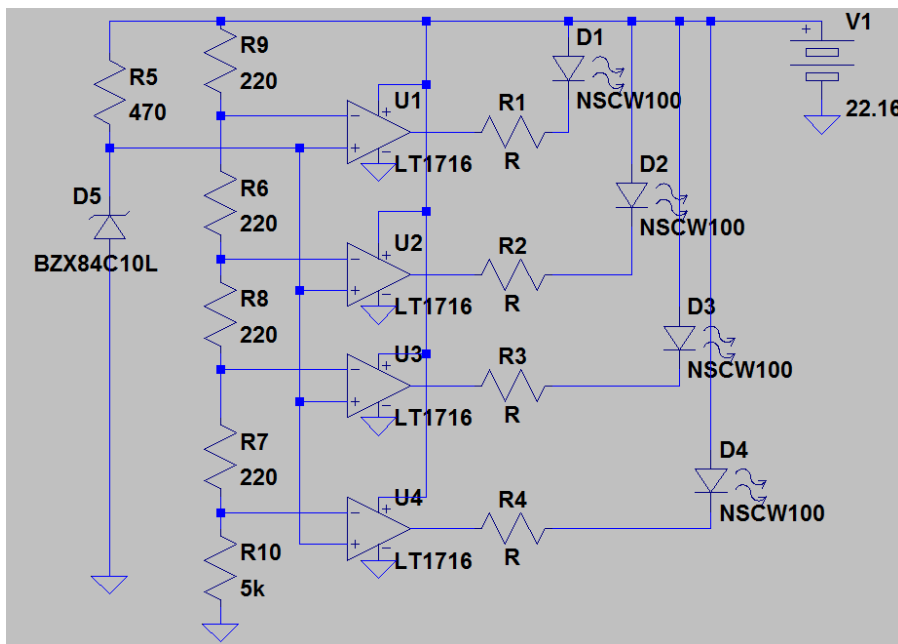

**Figure 26: Battery Monitor for 24V System**

The battery monitor will show the status of the 24v battery bank using four LEDs, one red, two yellow and one green. Two LT1716 dual comparators will be used in the circuit because of the high supply voltage. The last three LEDs will indicate the charge status in

by variables of 25% of the charge difference from full and dead. The LED battery display in can be tested with the voltage source. The comparator circuit in Figure X should be tested at 0 to 26V. After the circuit is built the voltage source should be connected where the battery is. There should be an initial voltage of zero. Gradually turning up the voltage should cause the LEDs to light up one at a time. The voltage across resistor R10 should be about 22.40V. The first LED should light up at 22.40V. The LEDs should light up every 1.10V increase until it reaches 25.6V. For every 1.10V increment the user there is a visual signal to let the user know. When the voltage is decreasing the LEDs should turn off in reverse order. The first LED will be red to let the user know that the battery is near its dead voltage. If a 24V system was connected and that light stayed off after a few minutes of charging then a new system would be required. The second two LEDs are yellow and light up at 23.50V and 24.60V. The last LED is green and indicates 100% voltage at 25.70V. Before the charge controller reaches the float charge state the circuit will switch to the dummy load. When the batteries are fully charged a relay will be used to switch the circuit to the dummy load. It will consist of a protection diode in series with a BJT that will provide the current. The circuit consists of a comparator connected to a potentiometer which will determine the dump voltage. The dummy load will consist of a number of high power resistors capable of absorbing power over the limits of the battery. The wind turbine should not produce that much power due to the fuse that will protect the circuitry.

## 5.3 Charge Controller

The charge controller for this system may exclude the float charging stage of the battery because of the switch to the dummy load. Therefore only the bulk charge and absorption charge stages will be utilized. Due to the Peukert effect and for the efficiency of the turbine the input current for the battery at the 20Hr rate, which is 26A, will be the base current. When connecting the system it is **very important** to connect the battery before connecting wind turbine because of the voltage swing. Also, when disconnecting the system remove the wind turbine first. Figure 27 displays the basic components of the charge controller system.

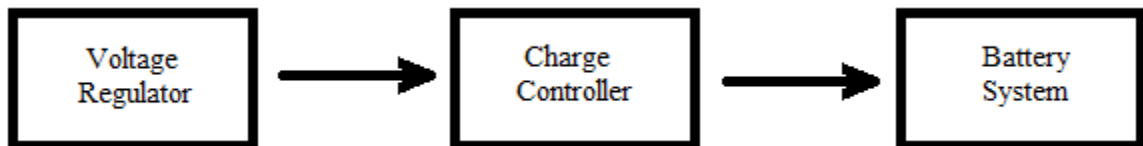

**Figure 27: Charge Controller Block Diagram**

To power the components a voltage regulator will produce a sufficient supply voltage to the circuit. It is our desire to use a switching regulator for energy efficiency however, for a less complex circuit the LM7808 regulator will be used to produce an 8V supply voltage. The maximum possible current will be driven into the battery for charging. With this component the voltage can be easily adjusted or changed to a more suitable regulation.

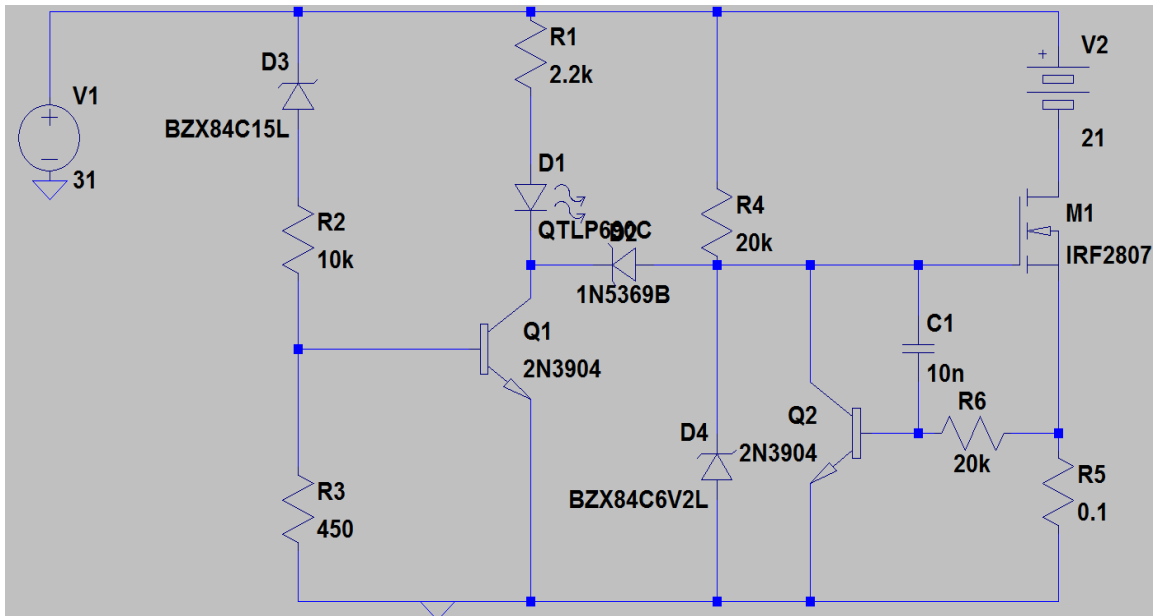

**Figure 28: Charge Controller Circuit**

For the primary part of the charge control unit we modified 24V charge controller circuit to our specifications. The input to the charge controller is the DC current from the voltage regulator at V. Output from the charge controller is 24-26V for the battery system. The essential current limiting components in the design shown in Figure 28 are transistors Q2 (NPN) and M1 (NMOS) and resistor R5. When Q2 switches on it short circuits the current going to the gate of M1. The voltage at the gate becomes zero and M1 switches off to limit the current through the battery under charge. Q2 will only switch when the voltage across the base-emitter is 0.7V. This is determined by the resistor R5. If the voltage across resistor R5 is 0.7V then Q2 switches on. Now the current through the battery is  $I_{bat}=0.7/R5$ . In the circuit design with an input voltage of 26V the zener diode reaches its breakdown voltage when the battery is up to 25V and Q1 switches on and shorts the gate voltage of M1. The LED will turn on when the battery is full. One of the modifications will be a Panasonic EW CB1-24V Automotive SPDT-relay that will switch from the battery to the dummy load. The wind turbines data suggests using a 40A fuse to protect the battery.

### 5.3.1 Maximum Power Point Tracking

Efficiency in this at this point will be determined by the MPPT. The maximum power point controls will begin at the DC-DC converter and end at the battery where a current shunt monitor will measure the current into the battery. A sensor will measure the amps coming in from the DC-DC converter and the power input will be calculated. Once that is done the tracker will determine the current need for the maximum output power. The algorithm will then change the DC-DC converter so that the current into the battery produces 95% power transfer. The value 95% was chosen because research showed that charge controllers are 92-97% efficient. In addition, the reason that 100% was not chosen

is that the calculations would force the DC-DC converter voltage to be equal to the battery system voltage which would not charge the battery system. Figure 29 shows the block diagram for MPPT. Below are the MPPT's calculated values and equations.

- $V_B$ , battery (load) voltage
- $P_{IN}$ , Power in
- $I_{MPP}$ , MPP current
- $P_{OUT}$ , 95% Power in
- $I_{IN}$ , New DC-DC MPP current (Just below actual MPP)
- $V_{IN}$ , New DC-DC voltage (Just below actual MPP)

$$I_{MPP} = \frac{P_{IN}}{V_B}; I_{IN} = \frac{P_{OUT}}{V_B}; V_{IN} = \frac{P_{IN}}{I_{IN}}$$

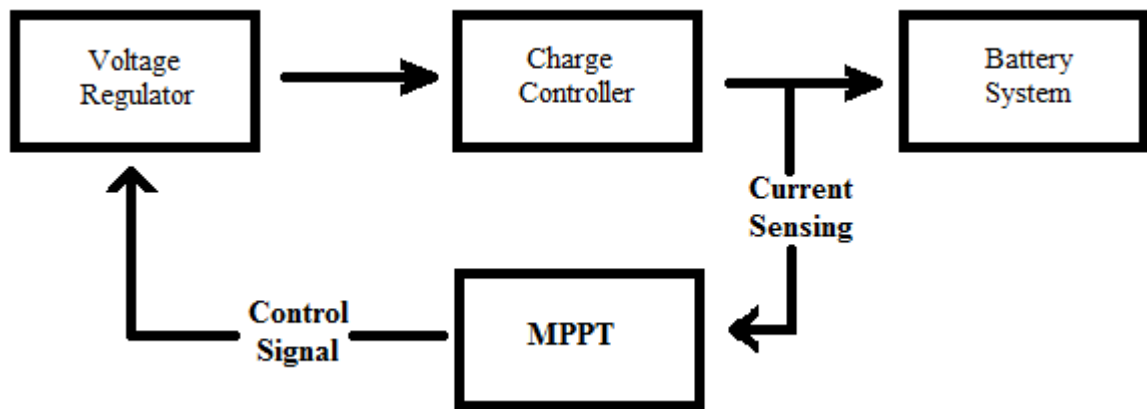
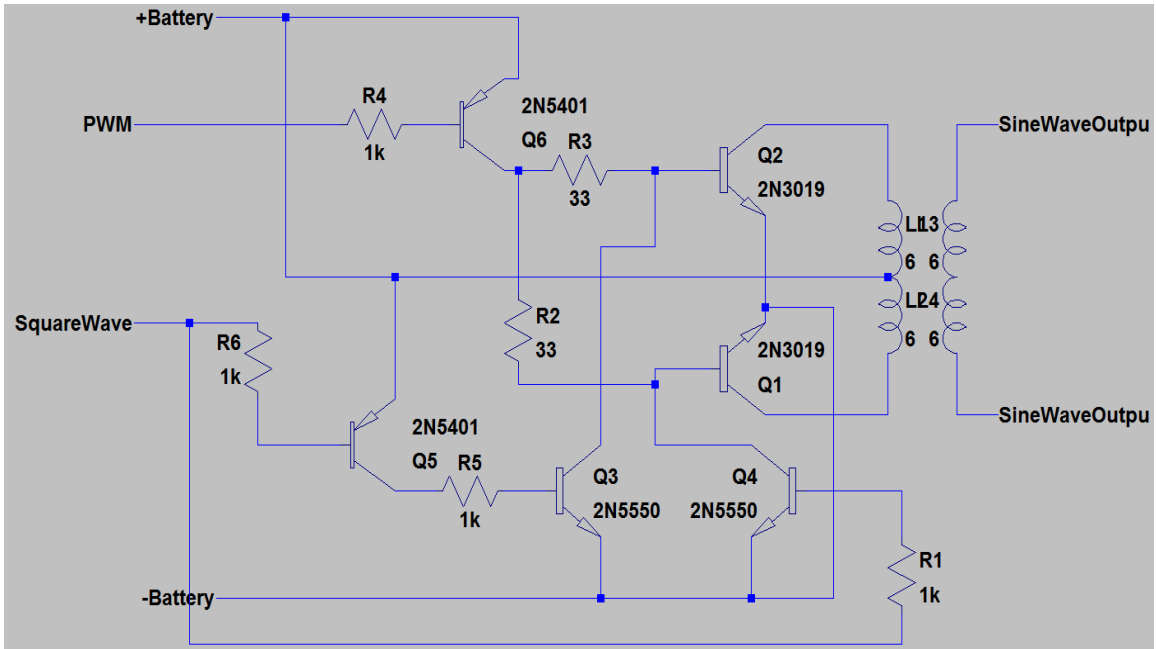

**Figure 29: Maximum Power Point Tracking Block Diagram**

## 5.4 Inverter

The design inverter was done with a 555 Timer IC. Because the time has a maximum supply voltage of 18V the battery system voltage will have to be converted down to at least 12V so that it does not destroy the circuit. From the first stage shown in Figure X the 555 Timer is used to produce a pulse width modulated signal. The two operational amplifiers are used as function generators. They produce a square wave output and a sine wave output that feed into the 555 Timer. The 555 is set to pulse width modulation mode with the square wave applied to the trigger in pin #2 of the Timer and the triangle wave that is produced by the second op-amp is applied to the control voltage in pint #5 of the Timer. The square wave input activates the pulse width modulator to generate a set of pulses at the output. The triangle wave modulates the signal width of the output square waves. The output generates a sine pulse wave modulated signal from the 555 Timer. In the next state the signal that is produced by the 555 modifies the battery signal that is





**Figure 31: Inverter Circuit Stage 2: Sine Wave Generator**

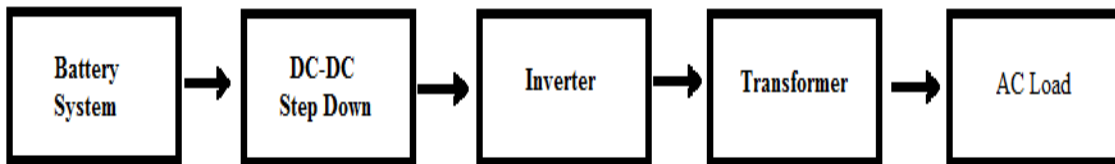

**Figure 32: Inverter Block Diagram**

After the inverter converts the DC voltage the output should be 120VAC. Although would not be hard to design a transformer with the correct turns ratio to produce 220VAC a \$20 transformer can be bought to convert step up the AC voltage.

## 5.5 Wind Sensors

As we have researched, we prefer that the data being sent from the wind speed sensor should be logged at a particular interval, all the while counting the number of switch closures (or pulses, as the case may be) on the anemometer and relating the rate of switch closures per period to the actual wind speed based on the proportionality constant on the anemometer. To interface this component with the microcontroller for precise data logging, precautions should be made due to the fact that the wind speed is highly capable of fluctuating wildly under different conditions. A de-bounce element such as a parallel capacitor is necessary to ensure more accurate pulse readings from the sensor, and a logic element such as a latch or flip-flop is needed to coordinate this process with the microcontroller's analog-to-digital converter circuitry and therefore have a discrete data value that may be further manipulated on the software level.

A suitable way to accomplish this is a J-K flip flop, in which J is 1 and K is 0. The pulse asserted by the wind sensor will be fed into the clock input of the flip-flop, and on a falling edge the output Q will act on the J=1, K=0 condition and be set to 1. This will then feed into the microcontroller proper where it can keep a running count of the number of pulses in the time interval. After a pulse is recorded however, the microcontroller will increment the pulse counter within the software, assert the CLR input that will be on the flip flop, and thereby reset Q to 0 to wait for the next pulse.

As the method of measuring the wind speed will lie purely in the software level with the wind rate calculation based on the number of pulses recorded, the wind speed sensor will not have to be passed through a microcontroller ADC. For this logic circuit to operate properly, a large 'pull-up' resistor connected to the  $V_{cc}$  supply voltage will ensure that a contact closure on the wind speed sensor will result in a high logic level. A schematic of our wind speed interfacing circuit with the microprocessor will follow in Figure 33. The switch represents the rotation of the cups and thus the contact closures due to wind.

The method for measuring wind direction differs a bit from this. As the direction of the wind is an angle measurement that must be quantified relative to the direction of the turbine proper, the resulting signal from the potentiometer must result in a voltage value proportional to the deviation angle measured by the wind vane. This output is fed into one of the Analog ports of the microcontroller, and from there the proportionality calculations are handled on the software side. By virtue of our formula, we've decided that it would be simpler to poll the wind direction at a time interval matching that of the current/voltage sensors, then compute the moving average at every data logging interval.

The wind vane we will use employs a potentiometer that measures impedance proportional to the angle of deviation from the center. However, the microcontroller that we use will not be capable of measuring this impedance without additional components; therefore, a simple voltage division using a 5V voltage from the microcontroller's power supply across the leads of the potentiometer will translate the impedance level to a measureable voltage level. To safely limit the voltage level to be fed into the ADC input on the microcontroller, an 80 kilo-Ohm resistor will be placed in series with the sensor assembly to have an easily readable voltage measurement for the microcontroller to translate back into degrees of rotation to be used in the averaging formula.

The schematic of the wind direction sensing circuit will follow in Figure 34. The pin on the Arduino Duemilanove that this circuit will feed to is the Analog input pin A1.

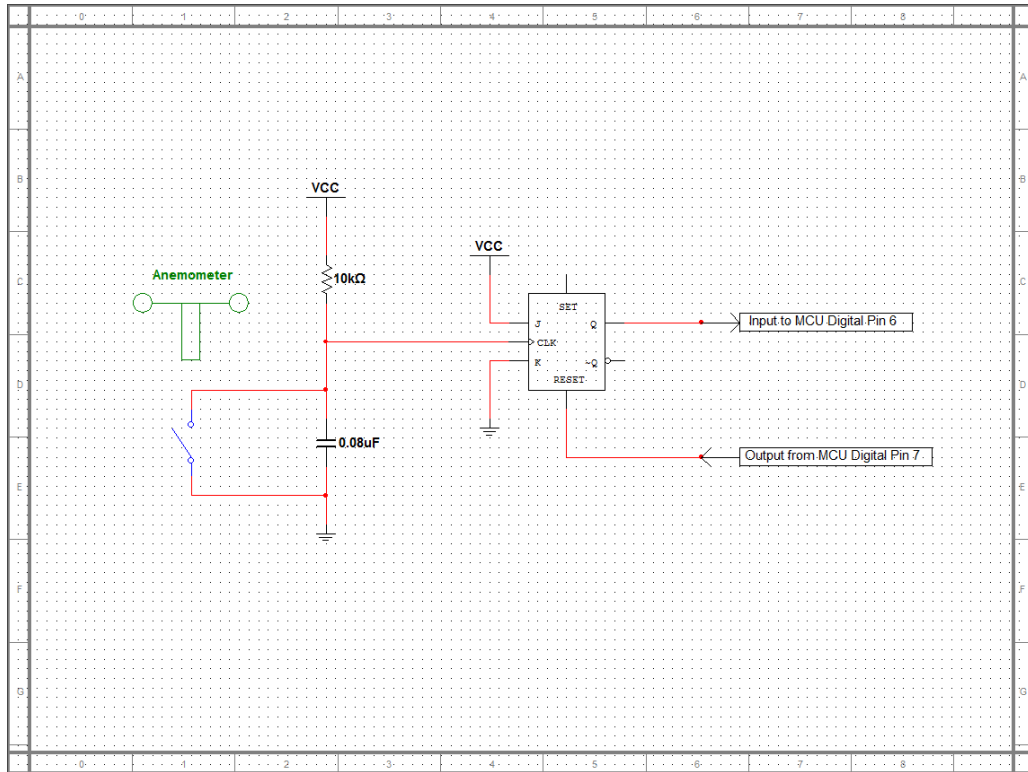

**Figure 33: Wind Speed Interfacing Circuit**

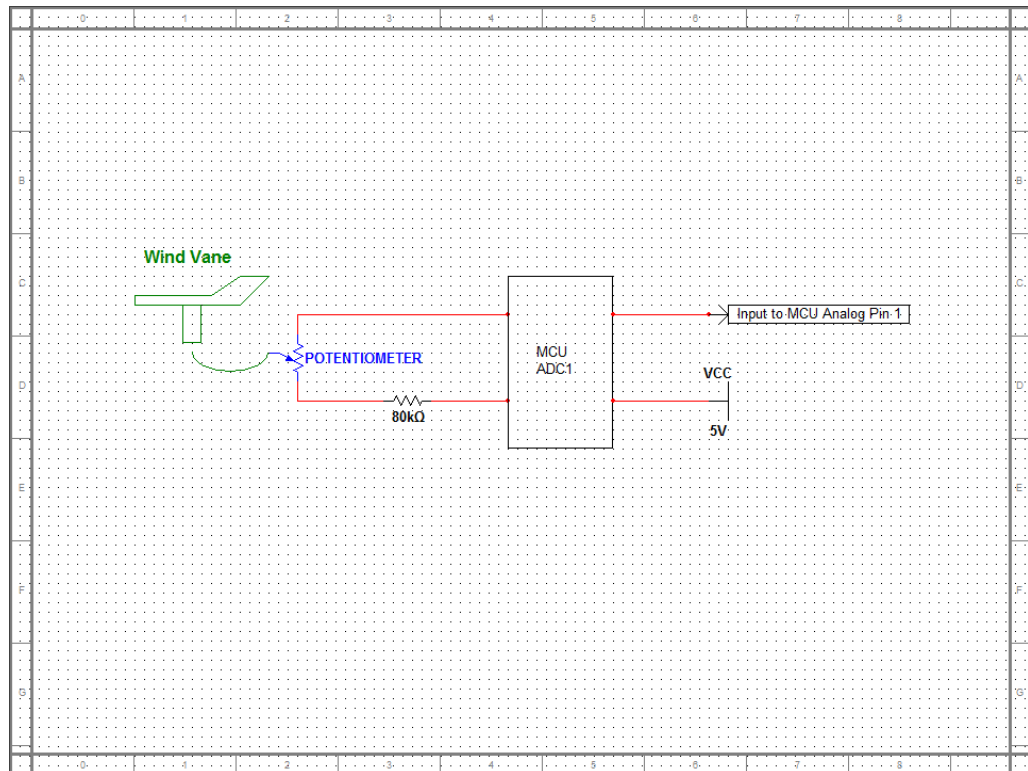

**Figure 34: Wind Direction Interfacing Circuit**

## 5.6 Voltage/Current Sensors

As outlined during our research, sensing the voltage between the battery terminals and the current being produced by the generator involves similar circuit topologies. The voltage sensing functionality of Intellaturbine includes a voltage divider circuit as a limiting element leading straight from the battery system, in line with an active low-pass filter for both frequency-regulating and anti-aliasing purposes. The input of the system will connect to the battery's positive terminal, whereas the output of the system will feed into the Analog input pin A2 of the Arduino Duemilanove board in order to utilize the built in Analog-to-Digital Converter functionality.

To measure the voltage of a battery system with a nominal voltage level of 24 Volts and – if under a charging condition – a voltage level of around 29 Volts, the sensor design must tolerate voltages of upwards of 30 Volts if necessary. Resistors in the circuit are configured to form a voltage divider system, such that this large voltage signal may be reduced for the subsequent low-pass filter network. These resistors should preferably have an error rating of 1% or less, since our objective here is to take the voltage measurement with as much accuracy as possible. Given a max voltage threshold of 30 volts, it is desired to have these two resistors sum up to a total in-line resistance of 150 kilo-Ohms, which limits the maximum current in the circuit to 0.2 milli-Amperes, as per Ohm's law. If the battery is operating at nominal levels, this amperage is 0.16 milli-Amperes; this comparatively low current will serve to limit the heat of the circuit due to thermal factors and further eliminate any risk of damaging the components.

Once the voltage is limited by the two in-line resistors, the resulting signal must be cleared of any sampling noise or anti-aliasing. To this end the low-pass filter system employing the Texas Instruments LMC6484 quad op-amp DIP and identical pairs of resistor and capacitor will be used. As stated, using this configuration will result in a unity-gain filter that does not further amplify the signal. As the purpose of these resistors and capacitors is to assert a low-pass filter behavior on the signal, a low error tolerance is not necessary. As for the LMC6484 op-amp package, the chip has a ridiculously low input current draw rated at 20 femto-Amperes. This allows the package to be powered by the Arduino's 5V DC output and thus further simplify the voltage data collecting process and calculations on the microcontroller side.

The path corresponding to the wind generator output is where the current sensor comes into play. The current sensing system featured in the Intellaturbine design will take the output current from the generator, translate it into a proportionate voltage, amplify it, and then feed this resulting signal into the same LMC6484 op-amp configuration. The limited, low-frequency analog voltage signal that this creates will feed into the Analog input pin A3 of the Arduino Duemilanove board to be sent to the proper ADC channel.

The device used to measure the current is the RMCF1/100R zero-Ohm resistor by Stackpole Electronics, which is best suited for directly measuring the voltage across it due to the prevailing current. This is placed in parallel with a special current monitoring device, or rather the ZXCT1009 high-side current monitor manufactured by Diodes

Incorporated. The device comes in a SOT23 package and will take the voltage developed across the shunt resistor and amplify it such that an output current can be produced and, when another output resistor is placed, scaled into an appropriate output voltage referenced to ground that can be safely fed into the low pass filter system and the microcontroller. Due to the inherent gain within the current monitoring chip, the output voltage level will be large enough to be read correctly by the analog-to-digital converter, all the while maintaining a safe input voltage for the MCU to handle. The desired voltage measurement of a maximum 20-Ampere current is 3 Volts. Therefore a 150-Ohm resistor will be sufficient for the circuit as per the following calculations. Where K is the gain constant of the current monitor rated at 0.01 Amperes-per-volt,  $R_s$  is the maximum load resistance of the shunt resistor rated at 0.1 Ohm, &  $R_o$  is the 150-Ohm output resistance:

$$V_o = I_o R_o; I_o = K V_s; V_s = I_s R_s; \text{ therefore } V_o = K R_o R_s I_s$$

This means that given an output resistor with  $R_o = 150$  Ohm, a sense current of 20 Amperes will result in an output voltage level  $V_o$  of:

$$V_o = K R_o R_s I_s = 0.01 * 0.1 * 150 * 20 = 3 V$$

After which the filter will act upon this current-measuring signal exactly as it does on the voltage measurement, where power to the filter is supplied by the MCU. The schematics of the voltage and current sensing systems will follow in Figures 35 and 36, respectively.

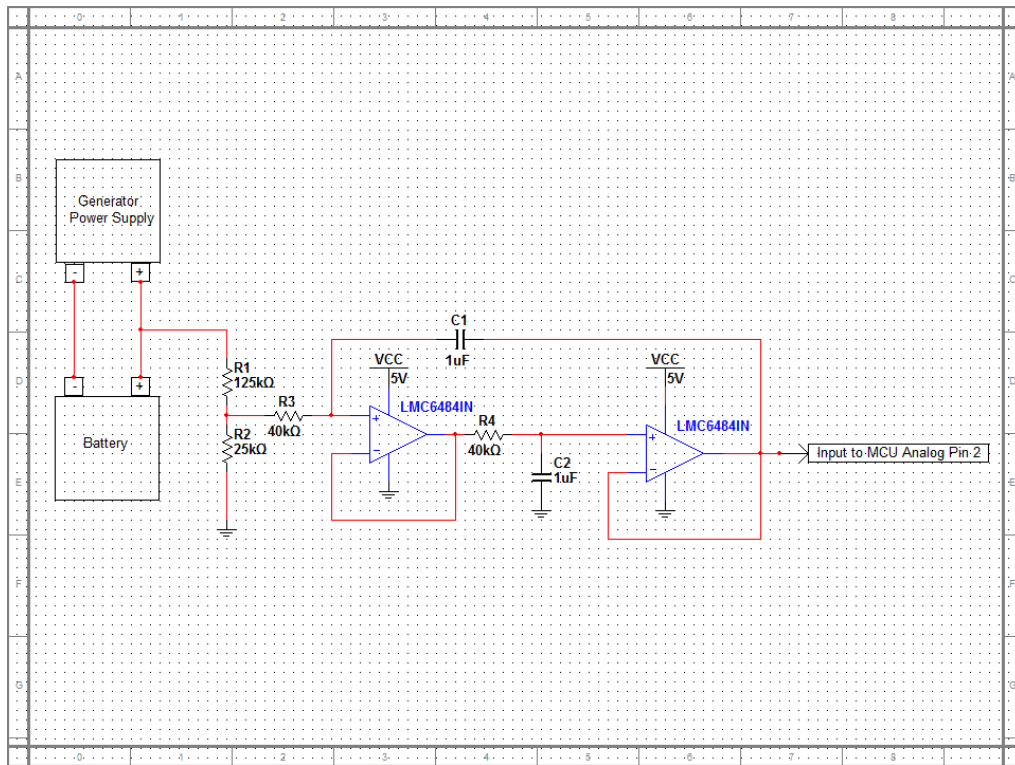

**Figure 35: Voltage Sensing System**

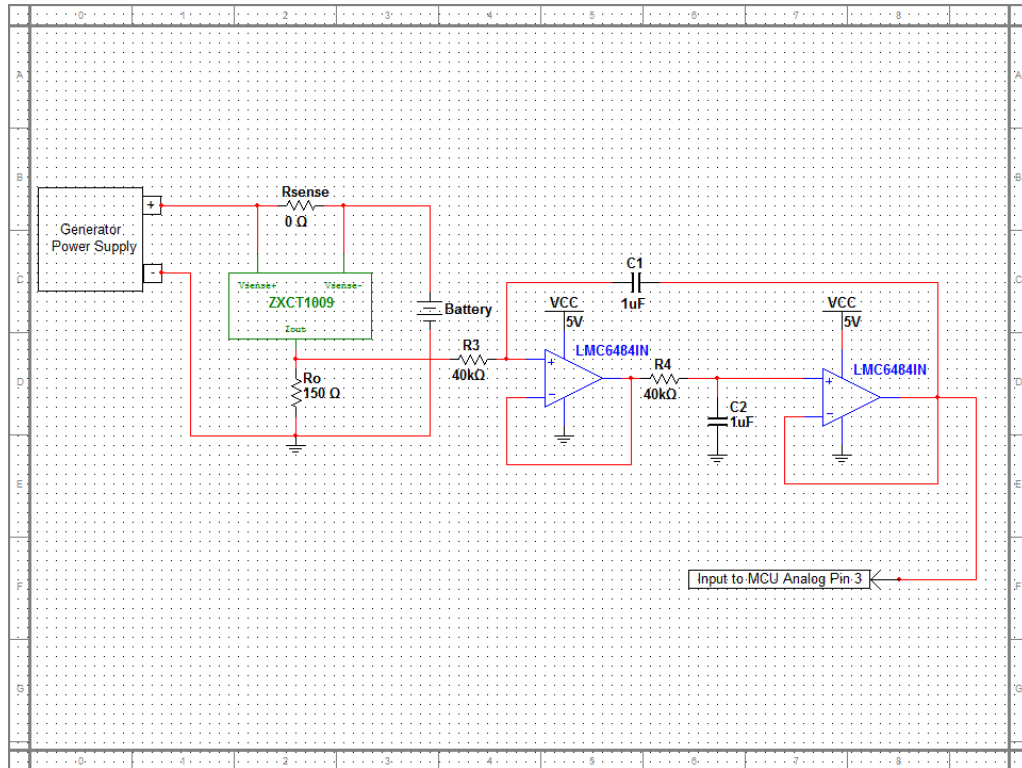

**Figure 36: Current Sensing System**

The goal of the low-pass filter in these systems is to allow them to respond to sudden variances in current or voltage, as the situation requires. In the case of the current sensor the passing magnets resulting from a rapidly closing reed switch may excite a much higher frequency than what is acceptable in the design. Not only that, but other exciting harmonic factors such as the rotation of the turbine blades also have a profound effect on the frequency of the current signal. Using the low-pass filter in tandem with our sensors, these high frequencies may be filtered out while low frequencies exhibit a gain of at least unity, or 0 dB on a logarithmic scale. Based on the RC characteristics of our filter, the cut-off frequency where the pass band ends comes out to be:

$$f = \frac{1}{2\pi RC} = \frac{1}{2\pi * 40 \times 10^3 * 1 \times 10^{-6}} \cong 4 \text{ Hz}$$

Since this is a second order filter, frequencies above the cutoff frequency will be more sharply attenuated and the gain will slope more steeply downward beyond the pass band. The magnitude of the transfer function of our filter mathematically comes out to be:

$$\left| \frac{v_o}{v_i} \right| = \frac{1}{\sqrt{(\omega RC)^4 - (\omega RC)^2 + 1}} \rightarrow 20 \log_{10} \left| \frac{v_o}{v_i} \right| = -10 \log_{10} [(\omega RC)^4 - (\omega RC)^2 + 1]$$

The plot of the signal gain response on our filter in dB as a function of signal frequency by a logarithmic scale, otherwise known as the Bode plot, will follow in Figure 37.

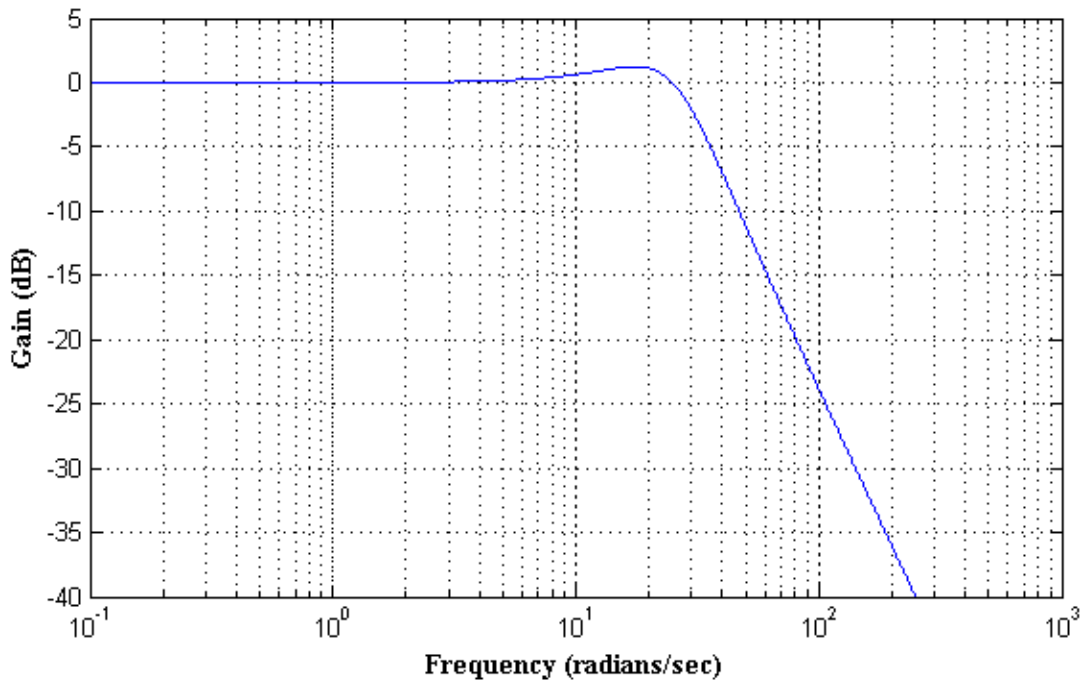

**Figure 37: Bode Plot of Second-Order Low-Pass Filter**

## 5.7 Microcontroller Power Supply

The microcontrollers and LCD display need a steady 5 Volts power supply. This voltage will be taken from a 24 Volts battery. Since the battery voltage is greater than the voltage needed to power the devices, a voltage regulator must be used to regulate the voltage to a constant 5 Volts. A circuit that maintains a constant output voltage is called a regulator. There are two types of voltage regulators that are available, those that work at a DC or constant operation point and those that are based upon varying a duty cycle of a pulse also known as switching regulators. The main objective of a voltage regulator is to maintain a constant voltage over various load currents. One parameter of importance is the load regulation parameter. This parameter gives the change in the output voltage as the regulator's output current is varied from a minimum to a maximum current. The power dissipated in the regulator is proportional to the voltage across the regulator. To minimize the power dissipated in the regulator, the goal is to use as minimum a voltage across it as possible. Another parameter of importance is the minimum allowable voltage across the regulator for the regulator to maintain a constant output voltage. In other words the regulator is still in regulation. This minimum voltage across the regulator is known as the dropout voltage. As with any electronic parts, there are maximum ratings that must be adhered to, such as the maximum input voltage, the maximum allowable load current, the maximum power dissipation allowed and the maximum operating temperature. Finally, since these parts are short circuit protected, the maximum short circuit current is also

given. As long as the maximum power dissipation and maximum operating temperature are not exceeded the part will operate indefinitely with its output shorted to ground. There are several items that will destroy one of these three-terminal regulators even if these parts are correctly installed and the maximum ratings are adhered to. The first is applying the wrong polarity voltage at the input. The second is having the output voltage greater than  $V_{in}$ . This can occur if  $C1 > C2$  and the energy storage in the output is greater than the energy storage in the input. This commonly occurs during power off if  $C1 > C2$ . The input to the regulator will discharge toward zero volts faster than the output. A good solution for protecting the regulator should the output voltage becomes greater than  $V_{in}$  is to use a diode across the regulator. Under normal use,  $V_{in} > V_{out}$ , and the diode is reversed biased. Should  $V_{out}$  become greater than  $V_{in}$ , the diode is forward biased, preventing any current flowing into the regulator from its output. The three terminal regulators can also be made to be adjustable so any desired regulated output voltage can be obtained. The only requirement is that the minimum voltage is that of the part itself. For example, a 7805 regulator can be made adjustable, but its minimum output voltage is 5 volts. When  $P_{in}$  is the input power,  $P_{out}$  is the output power, and  $P_{reg}$  is the power dissipated in the regulator. The efficiency of a voltage regulator defines the percentage of power that is delivered to the load and is given by the following equation.

$$\text{Efficiency} = (\text{Output Power}/\text{Input Power}) * 100\%$$

The LT1761 series are micro power, low noise, and low dropout regulators. With an external 0.01mF bypass capacitor, output noise drops to 20mVRMS over a 10Hz to 100kHz bandwidth. Designed for use in battery-powered systems, the low 20mA quiescent current makes them an ideal choice. In shutdown, quiescent current drops to less than 0.1mA. The devices are capable of operating over an input voltage from 1.8V to 20V, and can supply 100mA of output current with a dropout voltage of 300mV. Quiescent current is well controlled, not rising in dropout as it does with many other regulators. The LT1761 regulators are stable with output capacitors as low as 1mF. Small ceramic capacitors can be used without the series resistance required by other regulators. Internal protection circuitry includes reverse battery protection, current limiting, and thermal limiting and reverses current protection. The device is available in fixed output voltages of 1.5V, 1.8V, 2V, 2.5V, 2.8V, 3V, 3.3V and 5V, and as an adjustable device with a 1.22V reference voltage. The LT1761 regulators are available in the 5-lead SOT-23 package. The adjustable version of the LT1761 has an output voltage range of 1.22V to 20V. The output voltage is set by the ratio of two external resistors. The device servos the output to maintain the ADJ pin voltage at 1.22V referenced to ground. The current in  $R1$  is then equal to  $1.22V/R1$  and the current in  $R2$  is the current in  $R1$  plus the ADJ pin bias current. The ADJ pin bias current, 30nA at 25°C, flows through  $R2$  into the ADJ pin. The output voltage can be calculated using the formula given in the datasheet of the device. The value of  $R1$  should be no greater than 250k to minimize errors in the output voltage caused by the ADJ pin bias current. Note that in shutdown the output is turned off and the divider current will be zero. Curves of ADJ Pin Voltage vs. Temperature and ADJ Pin Bias Current vs. Temperature appear in the Typical Performance Characteristics. Figure 38 is the schematic for the LCD power supply.

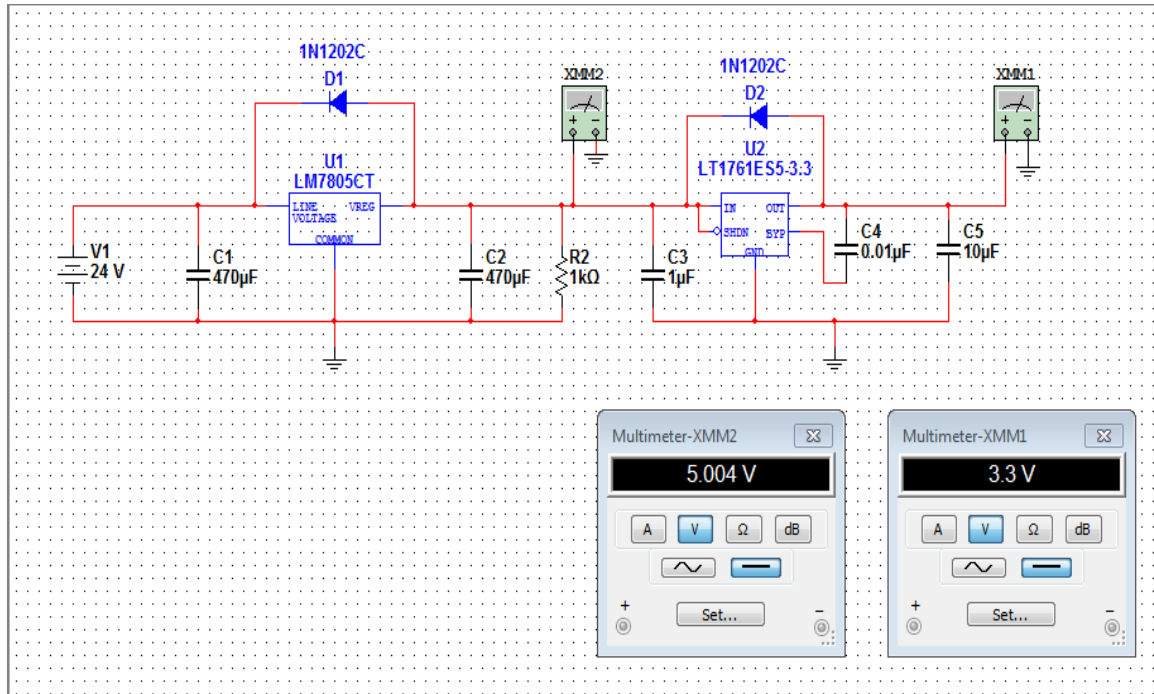
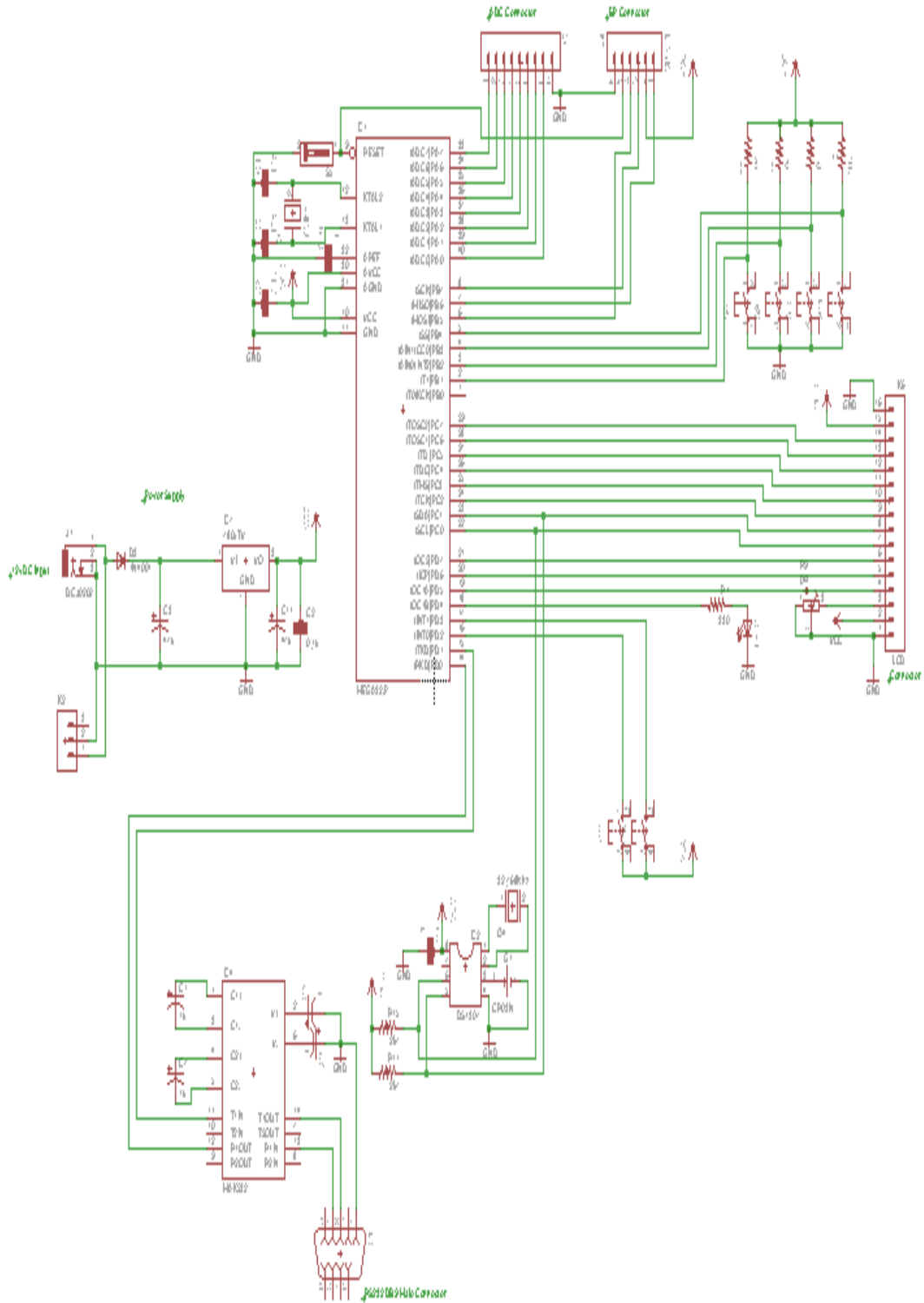

**Figure 38: LCD Power Supply**

## 5.8 LCD Display

Since the LCD display operates on a 5 Volt input and the microcontroller operating voltage is also 5 Volts, there is no need to use a fancy interface because the microcontroller's pin have enough drive capabilities to drive the LCD display without problems. The microcontroller like any other digital circuit operates in discrete clock cycles, which generally means that there are sudden demands for power at the beginning of every clock cycle, when all the bits are flipping. While on average the microcontroller doesn't use much power, the battery and voltage regulator alone often can't reliably provide these spikes in demand. Adding a capacitor across it ensures proper operation when the battery and the voltage regulator can't provide reliable power during the spikes. To control the contrast of the LCD display a resistor must be connected between Pin 3 of the LCD and ground. We used a resistor because we were not interested in varying the contrast. An alternative to that is to use a potentiometer between the Pin 3 of the LCD and ground, which would give you the ability to modify the contrast on the LCD as wanted. The Hitachi HD44780 LCD display is one of the most common types of LCD displays; it uses the standard protocol for sending characters to the LCD. This protocol sends 4-bits of data to the LCD at a time. These data bits are carried on the LCD pins 11, 12, 13 and 14. Since a character requires 8-bits of data to be send, the 4-bit operation mode sends two of these 4-nibbles. The other two principal connections that the LCD needs from the microcontroller is the signal that determines whether you are sending data or a control command. LCD pin 4 is responsible for the control command and LCD pin 6 is the signal that tells the LCD that a new nibble is ready to read. To be able to program

the chip, we need to be able to connect to a computer. First we have to set up a switch that will tell the microcontroller whether it should run the program that is already on the chip, or if the user is trying to program new code onto it. The microcontroller has a Serial Interface for communication. Most computers only have USB ports, so a USB to Serial interface must be used to program the microcontroller. The LCD display comes with an LED back light. Before using the backlight, it is necessary to reduce the current because the backlight draws too much current for the battery. On the manufacturer's datasheet we checked that the backlight operates at a forward voltage of 4.2 Volts and could withstand a maximum current of up to 180 mA. Since we know that  $V = I R$  and we know what  $V$  is, we can choose  $R$  to set the correct current  $I$ . To save power, we decided to operate at a lower brightness and a lower current. With a 33-ohm resistor, the LCD backlight can operate with a 27.3 mA current. An alternative design is to use a potentiometer to manually control the brightness of the LCD backlight. Since our primary concern is to conserve power, we decided not to use a potentiometer to save money and power consumption. The schematic of the LCD interface to the microcontroller is given in the figure below. The microcontroller is an Atmega32-P. The Atmega32-P has 32Kbytes of programmable flash memory on board making it the perfect microcontroller for our application. Figure 39 shows the final connections between the LCD display device and the display microcontroller.



**Figure 39: PCB Layout for LCD Display**

## 5.9 Rotational Control System

The Intella-Turbine design comes with a rotational control system for tracking wind direction and speed for maximum power generation. Our wind turbine structure consists of two turbine fans mounted on an axis that's connected to a gearbox and a servomotor. The servomotor will provide the required torque to move the wind turbine in the direction of the wind for maximum efficiency and power generation. The wind speed and direction sensor will be mounted on top of the nacelle of the turbine and continuously give out reading of the wind speed and direction.

The primary function of the direction control system is to monitor the wind direction for maximum power generation from the wind turbine. The wind sensor will take the wind direction as an input and give an output voltage that's proportional to the wind direction measured by the sensor. That output voltage will be the reference input voltage to the control system. For better versatility and flexibility we have decided to digitally control the system. Digital control systems offer many advantages over analog systems because they are easy to configure and reconfigure through the usage of software and because they are less prone to parameter changes in the system due to environment conditions such as temperature. The input reference voltage will be converted to a digital signal through the analog to digital converter box. That signal will be fed to the digital controller for compensation purposes and then converted back to an analog signal to be used by the motor. The output of the motor will be feedback as a digital signal to the system for stability purposes. As long as the feedback voltage of the system is not equal to the input reference voltage, the control loop will keep on going until the feedback voltage equals the reference input voltage. Once the system reaches that condition it will become stable and the motor shaft will be at the desired angle for maximum power generation from the turbine.

The secondary goal of the Intella-Turbine rotational control systems is to keep track of the number of full circular rotations made by the turbine fan. This is of primary concern because the cables attached to the rotating part of the turbine structure will be connected to non-rotating parts. So the use of cables brings a mechanical operating limit to the number of full circular rotations made by the turbine fan. If the turbine exceeds the number of full circular rotations allowed, it will result in physical damage to the structure. After researching possible solutions to this problem we came to the conclusion that using a custom made part to limit the number of full circular rotations would be very expensive and out of budget. The best and cheapest alternative to achieve this goal is to use software in the rotational control system to limit the number of rotations. Once the rotational system exceeds a predefined parameter, the Intella-Turbine will unwind itself back to its neutral position to prevent any structural damage.

The final design goal of the Intella-Turbine is to have speed control of the turbine fan. This is a critical feature of the design because the wind turbine has a maximum operating speed or RPM. If the turbine goes above that threshold speed, it will exceed its design capacities and could possibly cause structural damage due to the high speed. What causes the Turbine fan to over-speed is the wind velocity, even though the wind velocity needed

to over-speed the turbine is very high, it can happen if there are severe weather conditions. To solve that problem we researched various braking systems but none of them had the characteristics we were looking for in our design. After further discussion we decided to use the rotational control system along with the wind speed sensor to prevent the wind turbine from over-speeding. When the wind speed goes above the predetermined threshold speed, the rotational control system will step in and start rotating the wind turbine blades tangential to the wind direction. This will decrease the efficiency of the wind to spin the turbine blades, and therefore it will slow down the turbine's RPM. The heart of the rotational control system will be a servomotor that it's controlled by the microcontroller. Since we are implementing a digital control system all manipulations and response characteristics of the system will be done thru the use of software. We decided to implement a digital control system because we want to be able to change parameters of the system to adapt to the weather conditions and make it more robust to changes in the system.

In order to properly design and control the rotational control system, the transfer function of the servomotor must be determined. Figure 40 shows the model of a permanent magnet servomotor. From the model of the servomotor we can find the transfer function of the system using mason's gain formula. We can see from the servomotor model that the transfer function of the system will be of third order. Later in the documentation we will provide a key assumption about the servomotor to reduce the order of the system and make it less complicated.

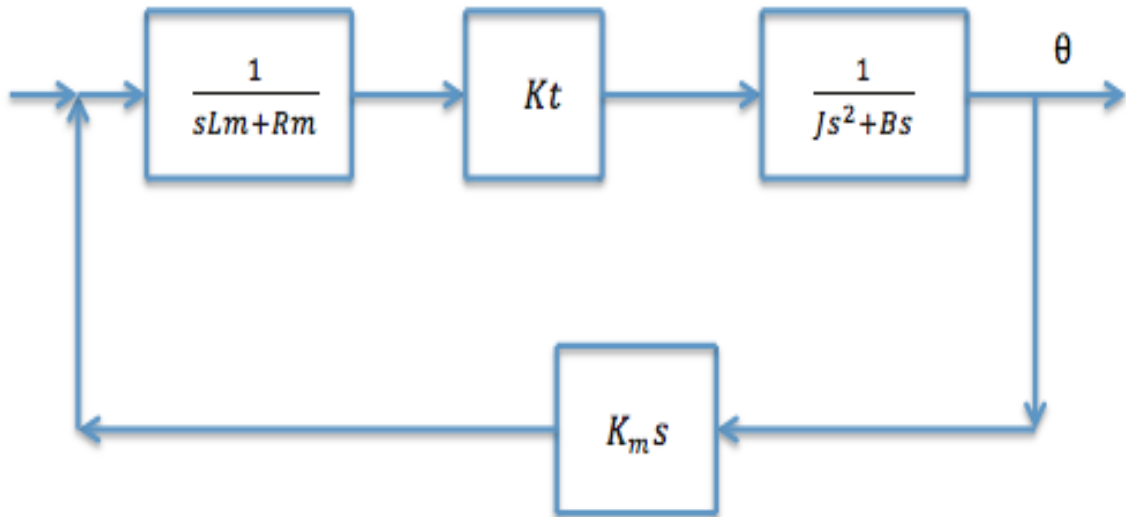

**Figure 40: Block Diagram of Magnet Servomotor**

From the servomotor block diagram above we can see that the transfer function of the motor is dependent on a few parameters.

The following list identifies all the parameters of the servomotor's transfer function and their meaning.

- **Lm** is the armature inductance of the servomotor
- **Rm** is the armature resistance of the servomotor
- **Kt** is the torque constant of the servomotor
- **Km** is the voltage constant of the servomotor
- **J** equal all the moment of inertia connect to the servo shaft
- **B** equals the air friction and the bearing friction of the servo

Using Mason's gain formula and some algebra we can determine the transfer function of the servomotor from the block diagram above.

$$G(s) = \frac{K_T}{JL_M s^3 + (BL_M + JR_M)s^2 + (BR_M + K_T K_M)s}$$

We can see from the equation above that the transfer function of the servomotor is a third order system. An approximation that can often be made for servomotors is to ignore the armature inductance  $L_m$ . For the case that the armature inductance is small enough to be ignored, the transfer function becomes a second order system. Substituting  $L_m = 0$ , we get:

$$G(s) = \frac{K_T}{(JR_M)s^2 + (BR_M + K_T K_M)s}$$

The Intella-Turbine rotational control system will feature several different operating modes. Most of them are determined by operating parameters of the system, while others may be engaged via the microcontroller. The primary operating mode occurs during regular wind velocity. As wind often is variable in direction, the microcontroller responds to the prevailing wind direction. The system will ignore wind shifts of plus and minus 15 degrees. Without this predefined parameter, the system will continually be rotating trying to adjust the position of the wind turbine, which will draw power continuously, thus unacceptable. The system will also ignore a change of up to plus and minus 15 degrees if it occurs for less than 2 seconds. When the prevailing wind direction exceeds this, the rotational control system will then begin tracking the change. The next operating mode occurs when it detects an over speed condition. Once wind velocity exceeds a predetermined speed, the system will then begin rotating the turbine blades to be tangential to the wind, it will wait for an over speed condition for 2 seconds before engaging. Finally, the rotational control system also keeps track of how many revolutions the wind turbine makes. This is an important feature because it will prevent the device from tangling with the power cables. When the system reaches its predetermined maximum revolutions in one direction, it will automatically unwind itself to the starting condition. The figure below represents the final rotational control system block diagram. The block

diagram of Figure 41 represents the rotational control system.

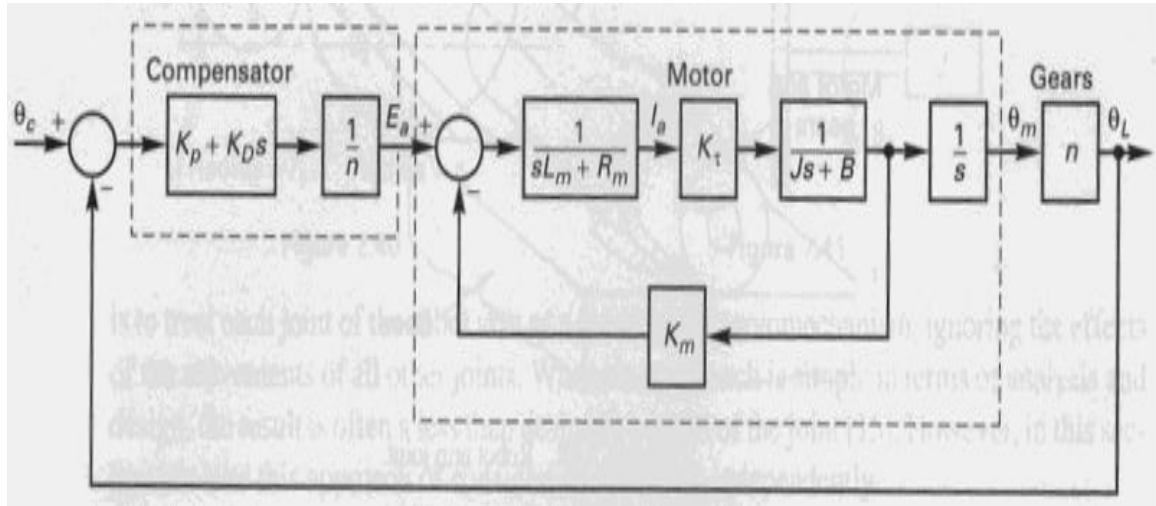

**Figure 41: Control System with Gear**

### 5.9.1 Gears

By closely analyzing the equation above we can note that the transfer function depends upon the inertia of the load being driven by the servomotor, as well as other parameters. The assumption of setting the armature inductance to zero can be applied only to permanent magnet servomotors because they have very low armature inductance. Another component of the final control system would be the gearbox. The gear ratio of a gear train is the ratio of the angular velocity on the input gear to the angular velocity of the output gear; also known as the speed ratio of the gear train. The gear ratio can be computed directly from the number of teeth of the various gears that engage to form the gear train. The torque ratio of the gear train can also be defined by the gear ratio. A gear train can be analyzed using the principle of virtual work to show that its torque ratio, which is the ratio of its output torque to its input torque, is equal to the gear ratio of the gear train. The equation for the gear ratio takes into consideration the radius of each gear. Also, the force exerted by one gear must equal the reaction force of the other at the point of contact, thus force is equal to the torque divided by the gear ratio. Figure 42 shows a similar mechanism to the one we are going to use with the Intella-Turbine.

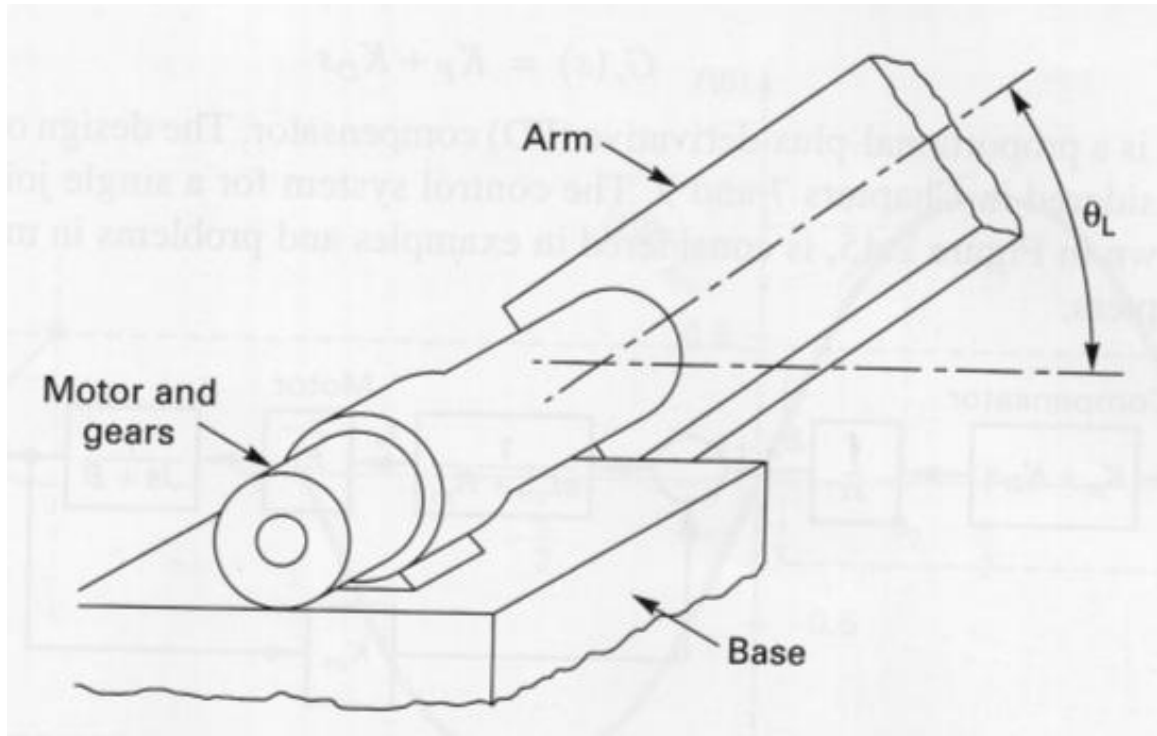

**Figure 42: Motor and Gear Connection**

## 5.10 Data Logging

### 5.10.1 Hardware

The microcontroller which we will be using for the data logging feature on the Intellaturbine is the ATmega328 processor, embedded within a host board, the Arduino Duemilanove. The Duemilanove contains most of the components to complement the 328's functionality and support development on the module, including a 16 MHz crystal oscillator, USB interface, power connection, and an ICSP header. This ICSP or 'In-Circuit Serial Programming' device greatly streamlines the development process by allowing us to upload new software and code to the device's on-board flash memory without having to wipe and reprogram it every time. The on-board USB interface mechanism, the FT232RL USB-to-Serial converter, will further simplify the development process by enabling the device to be connected to a USB port on any personal computer or laptop and having the programming code and functions uploaded to the Arduino in this fashion. The Duemilanove can operate at a 5V DC voltage level, with an input voltage limit of up to 20 Volts, though practically this voltage should not exceed 12 Volts. The ATmega328 itself, using the PDIP form factor on the board, has 32 KB of programmable flash memory to support our coding, 2 KB of internal static RAM, 1 KB of EEPROM, 14 digital I/O pins, and 6 analog input pins due to the built-in 6-channel 10-bit Analog-to-Digital converter within the chip.

The chosen Adafruit data logging shield that was designed to be compatible with the Arduino contains features that are much desired in any data logging mechanism. The most obvious and important of these is the slot for the SD card. The SD card interface will feature a level shifter to shift the nominal 5V supply voltage level of the Arduino host board down to 3.3V to more safely handle the SD card itself, preventing damage during reading or writing. This is accomplished using the Texas Instruments® 74AHC125N chip, which is a DIP of four tri-state buffers. Elsewhere on the device is the DS1307 Real-time clock chip which connects to the Arduino host board via the I<sup>2</sup>C interface. As the main power supply of the Arduino is not guaranteed to provide the necessary current to support these peripheral functions, the shield will also feature an on-board 3.3V power supply – namely, the MCP1700-330 Voltage Regulator IC. This device will provide up to 250 mA of current to be used for any of these processes. As the shield will be mounted directly on top of the Arduino board proper, largely obscuring it, the shield includes a prototyping area where the various external sensor input leads can be soldered in where appropriate. The following diagram is a revision of Figure 3, outlining the exact connections that the Arduino and data logging shield must make to implement the peripheral functions – in Figure 43 on the following page.

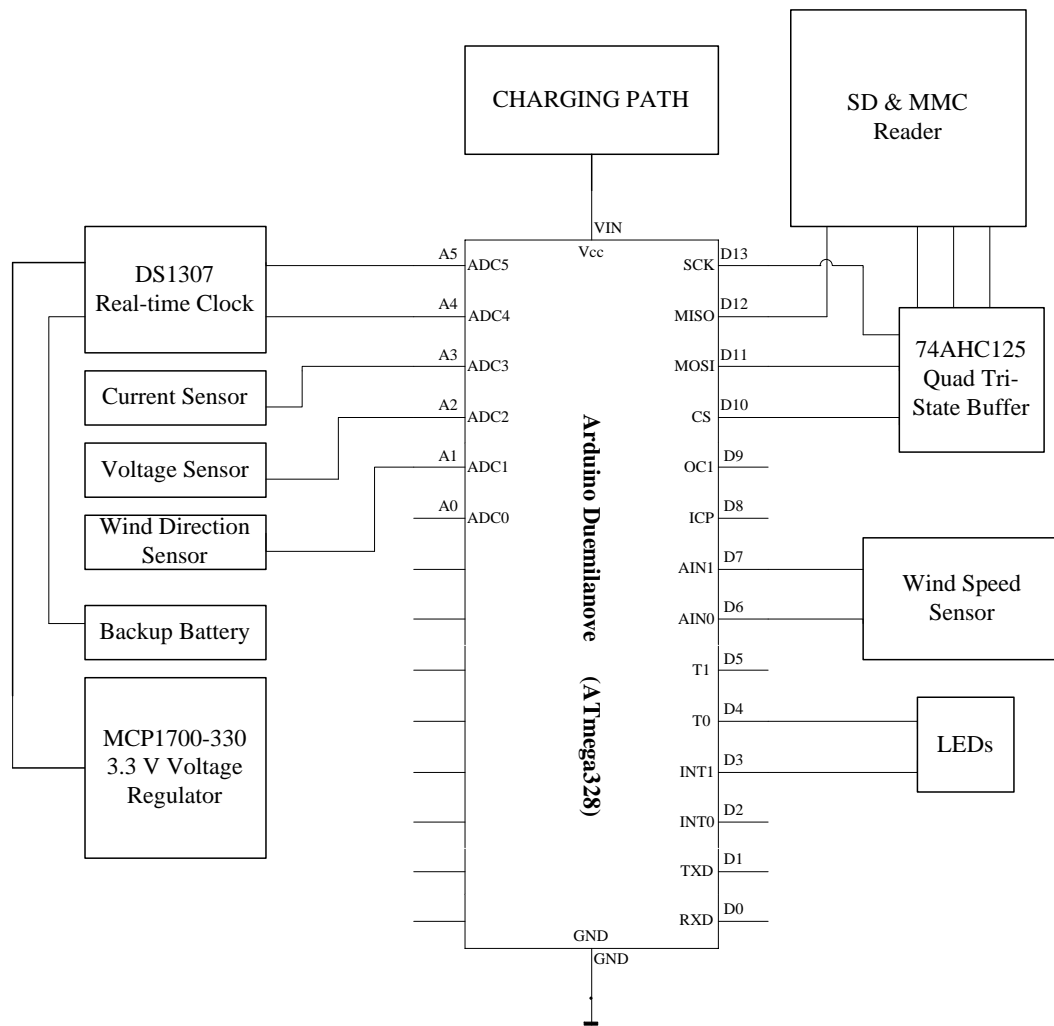

**Figure 43: Connections between Host Board and Data Logger**

At the very minimum the data logging subsystem will take 5 of the 6 analog inputs, A0 through A5, and 5 of the 14 digital inputs, D0 through D13, on the Arduino Atmel-based board. As outlined, the wind speed sensor will take one digital input pin, D6, for sending pulse information to the Arduino as the sensor reacts to the wind. The wind direction sensor will occupy one analog input pin, A1. This signal will be a quantifiable angle measurement of the deviation between the wind direction and the direction of the turbine blades and thus subject to analog-to-digital conversion. The voltage sensing system will come out to analog input pin A2 to be acted upon by this particular ADC channel, and the current sensing system comes out to analog input pin A3. As part of the marrying of the Arduino host board and the data logging peripheral, analog input pins A4 and A5 will be reserved for the DS1307 chip's two-wire I<sup>2</sup>C interface. The integrated SD/ MMC reader component will communicate with the Arduino via 4 digital input pins, D10 through D13. D10 is the chip select pin for this particular device and is integral for any relevant data logging software written for the device to properly recognize it.

## 5.10.2 Software

The software to be used for the data logger is the Arduino IDE. The language this environment supports contains many recognizable data structures and functions from the C coding language, and will ease development for the board. In a general sense, the goal of our data logging program is to initialize and assign the correct pinout assignments, initialize the peripheral data interfaces of the SD card, the LEDs, and the real-time clock, operate the JK flip flop on the wind speed sensor, proceed with collecting the raw serial data from the ADCs, and writing this data to the SD in a sequential fashion with a time stamp in a .txt or .csv format. The pulse pattern coming from the wind speed sensor, along with the user-defined data logging interval will provide the averaging calculation that relates the number of pulses recorded per time interval to the proportionality constant specific to the wind speed sensor. ADC-converted voltage input leading from the wind direction, current, and voltage sensors will be translated to the equivalent data values of their respective measurements determined by the following table, Table 11:

Parameter	Input Range	Translation	Proportionality Constant	Data Range
Wind Direction	0 to 1	Volts to Degrees	360	0 to 360
Voltage	3.3 to 5	Volts to Volts	6.0606	20 to 30
Current	0 to 3	Volts to Amperes	6.6667	0 to 20

**Table 11: Signal-to-Measurement Proportionality Table**

After the correct proportionality constants are multiplied by the input voltage signal level, we have our data values that can be accumulated every 5 seconds into a running total of each parameter, over the last minute before the data is logged. After the data logging interval has passed, the accumulated totals of each parameter are divided by 12, for one measurement per 5 seconds over one minute (60 seconds).

To set up this interval to begin logging data, a timer must be initialized that can call an interrupt routine every 5 seconds for the board to check whether the timer has arrived at the minute before the data logging interval. Additionally, a data string must have been initialized during setup, which will contain the plain text that is to be written to the SD card. Before any data is written, a time stamp sent from the real-time clock will print the present calendar date and time into a data string followed by a commathat delimits each following value. The calculated average of each parameter is then added to the data string, followed by a comma. When the main timer reaches the data logging interval, this accumulated data string is written to the .txt or .csv file, at which point the parameter sums, timers and pulse counts are reset to zero. Preferably we wish to have the LEDs included on the data logging shield to blink when an important action is taken such as the onset of the data logging interval and for every rotation on the wind speed sensor. A rough flow chart of the data logging program will follow in Figure 44:

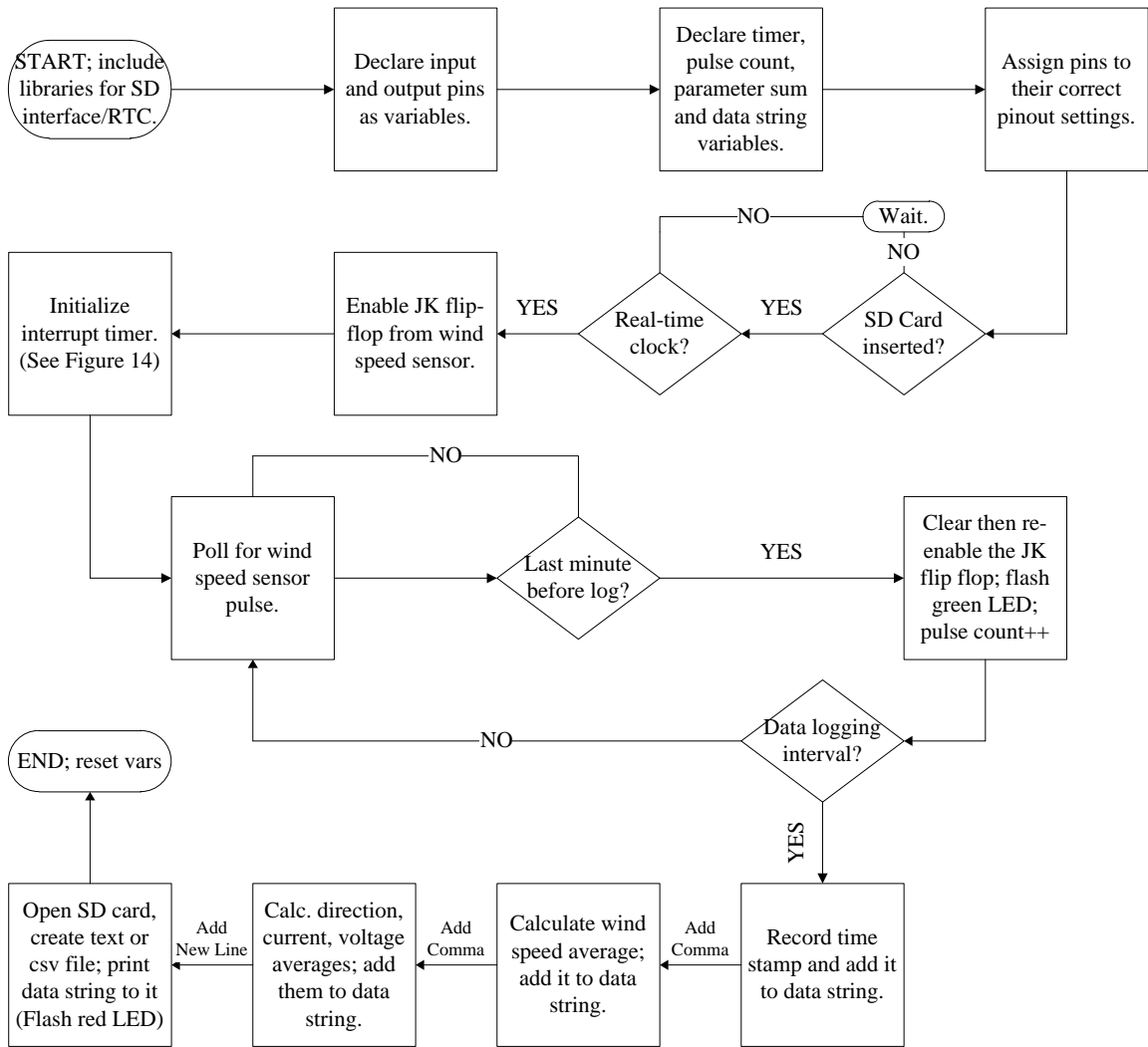

**Figure 44: Sketch of Main Data Logging Routine**

The interrupt routine of the data logging software system will be outlined in Figure 45, on the following page. The interrupt timer initialized at the start of the program sets this process in motion of calling the routine every five seconds.

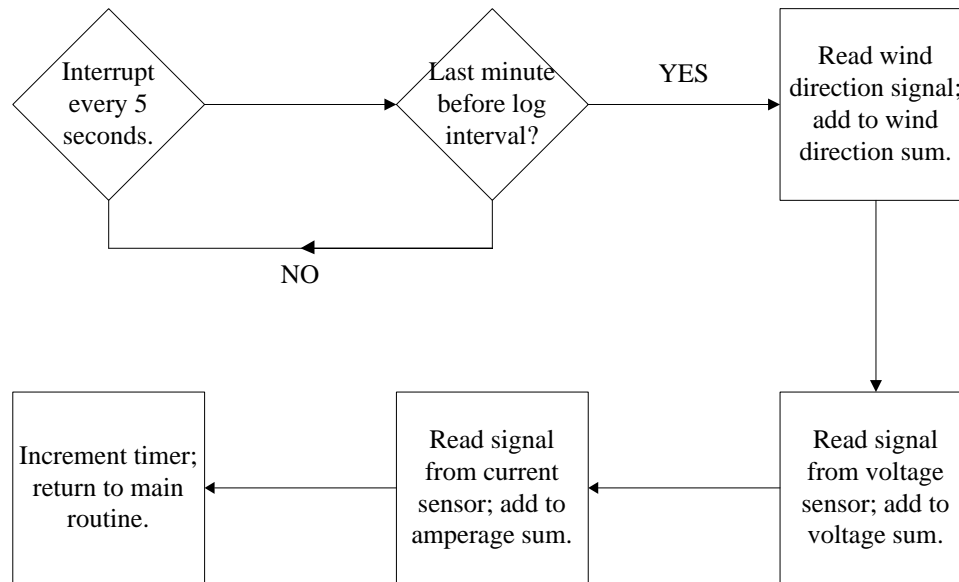

**Figure 45: Data Measurement Subroutine**

Following this logic, after a time the .csv file created in the SD card will contain a table of time stamps followed by a series of delimited parameter values, each time stamp creating a new line in the file. This obviously enables the use of spreadsheet software by the end user. As the final code is not available to us at this very moment, it should suffice at this point to not only have the program logic outlined, but have a list of variables that are important for the program to function. Such variables are listed in Table 12:

Variable Name	Variable Type	Description
chipSelect	int	Hardware chip select for SD card reader
windSpeedIn	int	Hardware pin that reads from wind speed sensor
windSpeedOut	int	Pin that resets JK flip-flop on wind speed sensor
currentSignal	int	Pin that reads from current sensor
voltageSignal	int	Pin that reads from voltage sensor
angleSignal	int	Pin that reads from wind direction sensor
gLedIn	int	Green LED pin
rLedIn	int	Red LED pin
logTimer	int	Counter until data logging interval
logInterval	int	User-specified data logging interval
pulseCount	int	Counts pulses from wind speed sensor for a minute
checkPin	int	Poll windSpeedIn to check if can clear flip-flop
iSum	longint	Running sum of raw amperage signal readings from ADC3

vSum	longint	Running sum of raw voltage signal readings from ADC2
thSum	longint	Running sum of raw wind direction angle readings from ADC1
gLEDStatus	boolean	Green LED on or off
rLEDStatus	boolean	Red LED on or off
dataString	string	Forms plain text output to file on SD
dateTime	string	Time stamp value from RTC chip
windSpeed	float	Sensor constant * (pulseCount / minute )
iAvg	float	Calculated average of current signal readings over a minute
vAvg	float	Calculated average of voltage signal readings over a minute
thAvg	float	Calculated average of wind direction signal readings over a minute

**Table 12: Variable List for Data Logging Routine**

One consideration to keep in mind is the duration the data logger can write data values into a single file before it becomes impractical to read such a massive amount of data from a spreadsheet interface. A way to circumvent this would be to add code allowing for the creation of a new text file after the real-time clock has recorded the elapse of a single day, and repeat this process upon a new day elapsing. Most importantly however, it should be noted that this Arduino microcontroller system is wholly dedicated to data logging. The libraries for SD card interfacing, RTC interfacing, and in general making sense of the data logging shield will take an estimated 15 kB of programmable flash memory from our main coding section, leaving little room for other necessary functions of Intellaturbine such as rotational control and the LCD display interface. For that, a separate microcontroller will be used. The parameter data that will display on the Intellaturbine LCD monitor will not necessarily reflect the data being logged into the SD.

## 6 Design Summary

After the different segments of Intellaturbine were designed, a complete summary of the project will now be presented. To begin, we will state the basic requirement for the design. Because our project is sponsored, there were certain design criteria that had to be met. The system had to be able to support the average house hold, removing it completely from the power grid. Hence, our sponsor stated that he wanted a wind generation system capable of producing 1000 watts at 24 VDC. The system must be user friendly, however, it should be so low maintenance that little to no end user input is needed once original parameters are set. The design should display real time data of output from the wind generator, output from the inverter, battery status, wind speed, turbine shaft speed (RPM), and DC voltage from the rectifier. The system should also have data logging

capabilities, accessible in a SD card format so that the data can be plotted in some data analyzing software to monitor and improve efficiency.

After extensive research and recommendation from our sponsor it was decided that two TLG-500 wind turbines would be the generators of choice for the project. This particular turbine was chosen for its real world, understated power output. The TLG-500 seems more expensive than a comparable stated output generator. However, upon further research it was noted that most generators were rated by instantaneous power and not real power like the TLG-500. This automatically made the TLG-500 option become more attractive as it is critical for the rest of our design the expected output of the generator is actually achieved. Since wind speed will be an important factor in how we generate power, a turbine capable of maximum output at low wind speeds is important. The TLG-500 does just that with maximum output at 28 MPH to 32 MPH depending on wind density. In keeping with our low maintenance requirement, these turbines are built very robust with bearings that are oversized and way overrated for the duty they are expected to perform. The turbines also address another problem common to wind generators, over heating. The unit's aluminum alloy case with its winding on the outer edge of the case acts as a huge heat sink there by minimizing this problem. This large robust design did come at a cost to the team; the turbines are more than double the weight of other common units. With the team planning on mounting both turbines on the same structure, certain mechanical considerations will now have to be put in place to deal with the weight of the turbines. Below is a table, Table 13, derived from information on the TLG website breaking down the expected outputs at various wind speeds from the turbines.

<b>TLG-500</b>			
<b>Wind Speed (MPH)</b>	<b>Voltage at Battery</b>	<b>Amps at Battery</b>	<b>Average Watts</b>
7	24	1	24
9	24	2	48
15	24.8	5	124
20	25.2	10	254
25	26.8	15	402
34	27.1	23	623
40	28.2	30	846
45	28.5	39	1111
50	29.8	50	1490

**Table 13:**  
**Wind Speed vs. Various Outputs Produced by the TLG-500**

Since wind speed is so important for wind generation, areas in the United States are best suited for this research. Below in Figure 45 is a map showing the areas best suited for this. It ranges from areas with the lighter colors being the worst candidates for wind generation to darker colors being the best. It should be noted however that even if you live in a white area of the map, your location could be uniquely suited to wind generation.

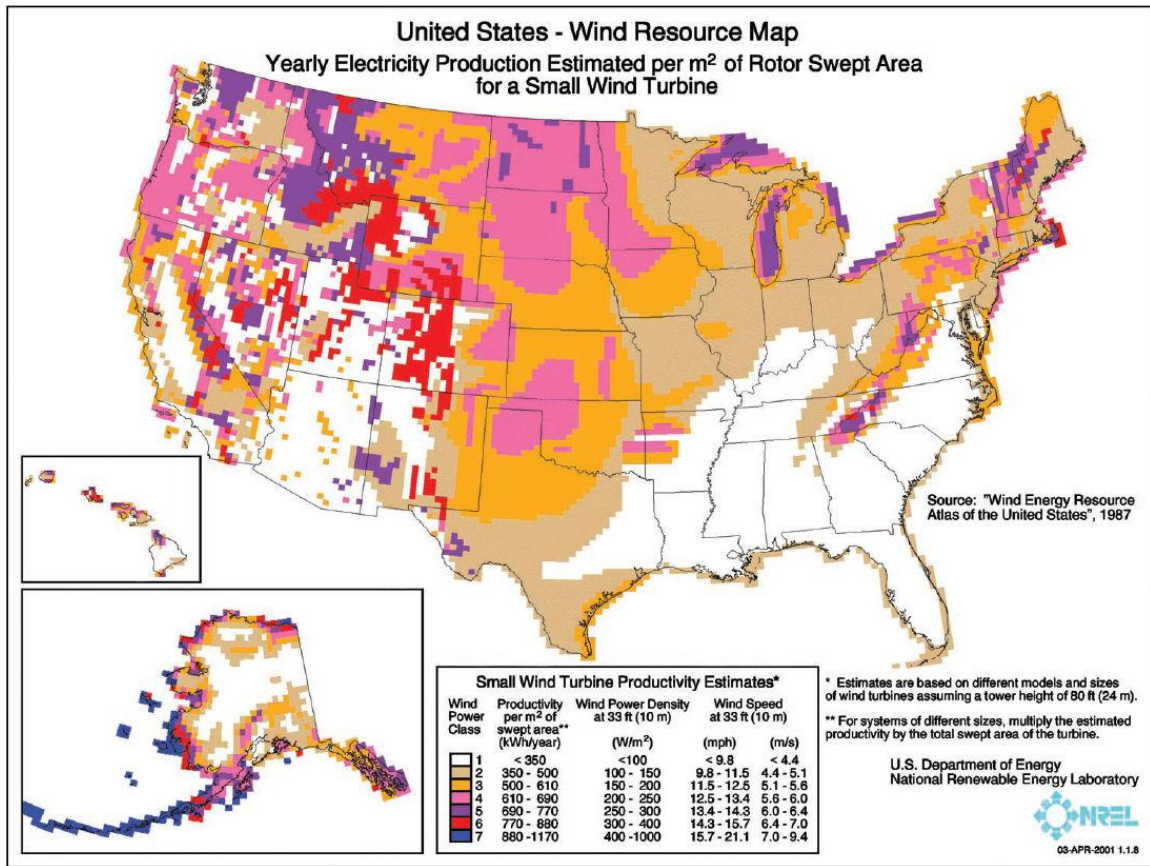

**Figure 45: Wind Resource Map**  
Permission Pending

Intellaturbine, as outlined by the requirements of the project, must have the capability to log data as it operates, provided an SD card formatted for FAT16 or FAT32 is inserted to take the data and store it into a plain text file. This function will allow for the user to draw his or her conclusions regarding the efficiency of both the design itself and the surrounding environment's inclination towards wind generation. While operation on the user's side may take some basic knowledge of everyday computing, the process is not complicated such that any further documentation is required for the user to learn how to open a program such as Excel and plot a graph using the data logged by our design.

The hardware components associated with the data logging subsystem are all of the sensors including that of wind speed, wind direction, voltage, and current, the ATmega328-based Arduino Duemilanove host board, and the peripheral Adafruit Data Logging Shield mounted on the Arduino via soldering to both supplement the ATmega328's data logging capabilities and to provide the entry point for the SD card. This peripheral will feature the DS1307 real-time clock chip to keep accurate time stamps for the data logger, the MCP 1700-330 3.3V voltage regulator in tandem with the 74AHC125 series of tri-state buffers to act as a level shifter to provide a voltage of 3.3 V to the SD card interface so as to not scramble the card.

The wind speed sensor's interface with the data logging subsystem is a JK flip-flop (set at  $J=1$  and  $K=0$ ) and pull-up resistor combination. As the sensor pulses due to the wind, the pulse will serve as the clock input to the flip-flop and thus set the Q output to high on the falling edge. After each such occurrence the data logging program logic will send an output signal from the ATmega to the flip-flop's reset input, allowing for the next pulse to cycle through. The Q on the JK flip-flop will feed into the Arduino's digital input pin D6.

The wind direction sensor will simply measure the resulting voltage reading from the potentiometer used by the sensor due to the microcontroller's 5V power supply, the resistance level encountered by the potentiometer, and an in-line resistor (forming a voltage divider). This signal is fed into the ADC1 channel of the ATmega, from which the data logger can calculate the resulting angle proportional to the digitized voltage signal being detected.

The voltage sensor that detects the present positive voltage across the battery system will consist of a simple voltage divider with an in-line resistance of 150 kilo-Ohms ( $125\text{ k}\Omega + 25\text{ k}\Omega$ ). This will limit the high voltage of the battery into a low voltage signal to be passed through an identical low-pass filter to the one used by the current sensor. The filter consists of two rail-to-rail LMC6484 operational amplifiers and an RC combination of  $R=40$  kilo-Ohm and  $C=1$  micro-Farad before each of their inputs. This second-order filter helps ensure unity gain on the signal within the pass band. After this process, the sensed voltage signal will pass through ADC2 similarly to the current sensor, and operated upon by the data logging program code.

The current sensor that detects the current being provided by the alternators due to the prevailing wind consists of the ultra-low-Ohmage RMCF1/100R current sensing resistor in a shunt configuration with the ZXCT1009 high-side current sense monitor, which will take the voltage across the shunt resistor as input and output a proportionally translated current level. This current level is led through an additional resistor to produce a suitable voltage signal that can be low-pass filtered for anti-aliasing and any spurious high frequencies that may impact the system. The limited, filtered voltage signal is then passed through the 10-bit analog-to-digital converter channel ADC3 to become digitally readable by the ATmega328, then recalculated back into the original current level sensed by the sense resistor by the program arithmetic and measured.

Design objective for the batteries that were achieved are as follows:

- Low Cost
- Durability
- Low Maintenance
- Low Self-Discharge rate
- Capacity

Hours of research materials from websites, such as BatteryStuff, Eneary1Batteries, and Battery University, suggested that all of these primary objectives were achieved by the selection of the lead acid flooded batteries. Although they have high toxicity and their

cycle life is not as good as some of the other batteries their advantages greatly out-weight their disadvantages and the advantages of other batteries. Another advantage that was not even sought out is that they have a very low internal resistance. As a secondary cell battery it is one of the most popular. One of main characteristics of the lead acid batteries that stood out is its low maintenance. Similarly another characteristic is that lead acid flooded batteries can be revived from the dead using pulse width modification. There is no other battery I know of that can return from dead voltage .It had one of the best suited for the wind turbine environment.

The capacity of the battery that was chosen was rated at 520Ah for a 20Hr rate. Six of them were selected to be a part of a 24V battery bank. This 2V cell system can hold up to 25.68V of charge, 2.58VPC. A LED display monitor will display the current charge held by the battery system. The display monitor is powered by the battery and is and consists of one red light, for low battery, two yellow lights, for 50% and 75% charge, and a green LED, that indicates a full charge. As the battery discharges the lights turn off accordingly. When the battery capacity gets full a relay will switch the current away from it into a diversion load that will dissipate the unwanted energy. Input into the battery is a current controlled by the charge controller and MPPT to optimize power transfer. Battery voltage is always monitored of efficiency. A 40Amp fuse will protect the battery from the turbine when the wind exceeds the safe operating zone. The output to the battery is and inverter that will convert the energy from the battery so that it can be used to safely power household electronics. We initially wanted to use two 12V batteries but they were so big and bulky that we would have a hard time carrying them to and from the senior design lab for testing and modifications every day.

A visual display of battery energy was needed Choosing the display was difficult because there were so many designs that had their own benefits. Some designs were very simple and cheap and worked very well when monitoring the battery. Other designs were show such as the bar graph LED battery level indicator which uses the LM3914. The datasheet for this IC comes with this application so it would be a breeze to setup and it would be a cheap circuit. Another setup that was considered was off of an open circuit website that uses diodes and BJTs that monitored the battery voltage and powered up the LEDs.

In the end the deciding factor was the design of the display was the fact that we wanted to design it ourselves. The battery display uses four LT1716 comparators to compare and detect the voltage in the battery system. The first LED, the red one, lights up at 22.40V of battery charge because that was by us, using calculations with cell voltages that we researched, to be the highest safe voltage before falling into dangerously low voltage levels as described in Table 1. The difference in that voltage and the maximum voltage, 1.10, was used to calculate the different voltages chosen to light up the LEDs. So going by table X the percentages are roughly 30%, 55%, 65% and then 100%.

The objectives for the charge controller were to safely charge a 24V battery system and monitor the battery while maintaining a sufficient voltage and current. The charge controller is responsible for switching the battery out of the circuit when it is fully charged and switching it back into the circuit when the battery system loses its charge. Specifications were that the charge time was 6 hours and the output voltage be adjustable

from 22.5-25V. However, for batteries rated at 520Ah at a 20Hr rate that would not be efficient and the adjustable output voltage was not yet achieved. Because this is a high power wind turbine it is capable of producing currents that can harm people or things. We have taken this fact into account and researched what kinds of wires need to be used for different components in our system. If we accidentally run a very large current through a very small wire there will be a disaster and catastrophic failure of the system. If we choose the wire gauge to be too large then there will be a voltage drop in the wire and nothing will work. Our system uses two wind turbines in parallel at 500 watts each so that means double the current. Since the power rating is 500 watts at 24V means  $21 \times 2 = 42A$  of current. So according to Table X a 4AWG wire is sufficient

Normally, secondary cell batteries are charged in three stages, constant current, constant voltage and float. The constant current stage charges the battery fast at which half the charging time has been elapsed. The constant voltage stage tapers off the current to a trickle for the next stage. The last stage is the float stage which only tries to prevent the self-discharging of the battery. The self-discharging rate for the lead acid battery is about 5% per month. The float stage was not necessary for this design because when the battery bank is full the charge controller uses a SPDT relay to switch the current to the dummy load. The input to the charge controller is the DC-DC converter which regulates the voltage for the system. The output of the charge controller is the battery system which the charge controller is responsible for transferring energy and keeping the system working at optimum efficiency. The charge controller also regulates the power to the other components of the system using voltage regulators, preferably switching regulators. The LM7808 is used to power the other ICs in the system so they can play their role in keeping the performance acceptable.

One design possibility was a charger circuit that made use of a linear regulator. As shown in figure X the circuit used an LM317 adjustable regulator. It could charge a 24V system and the current and voltage were adjustable. The original charge controller was modified from an open source website, Instructables, to only use the constant current and constant voltage stages of charging secondary cell batteries. It was also augmented to be efficient in transferring power from the DC-DC converter to the battery system. Basic charge controllers keep the batteries from being over-charged and protect them from reverse current. This controller design utilizes the IRF2807 high power MOSFET to restrict and allow current to pass through the battery bank. Figure X shows the schematic of the charge controller circuit. When the voltage at the gate of the MOSFET reaches 4V it switches on allowing for current flow. The 2N3904 NPN transistors will short circuit at the node where the NMOS gate voltage is to restrict the current through the battery. At extremely high winds the turbine will produce too much current and so an automotive SPDT relay will stop the current from traveling through the circuit.

Analysis of the circuit in the testing stage was tedious. Confusion occurred the battery was fully charged but the gate voltage on the NMOS read 6V. This was due to the fact that there was a BZX84C6V2L 6V zener diode at that node. Some of the circuit components had to be changed due to the fact that the original components were unavailable for the analysis. The replacement parts were not a definite match to the

originals for instance, diode D3 in figure X is a 15V diode whereas in the original circuit it is a 10V diode.

The objective for the overall effectiveness of the system was for a high efficiency power storage rate. Our sponsor showed a desire for us to use a fairly new design technique that will closely match the input power to the output power using the DC-DC- converter to change the voltage and the current into the battery system. Maximum power point tracking is a new way to increase the power efficiency in a system. Extensive research went into finding out the different techniques and applications for maximum power point tracking. A handful of techniques optimized the power output by calculating the maximum power that the wind turbine can absorb from the wind and convert into mechanical energy. These techniques did so by gathering quantitative values from the wind turbines. These methods were not a design possibility for us because of this fact. Most wind turbines do not supply all of the values needed to calculate the power that is converted in to mechanical energy. Therefore we had to work with what we had.

Also most of the other maximum power point tracking methods that were available was for applications in photovoltaic cells. Arduous research finally lead us other design methods using the wind generator's power output was available to us. The four possible design methods that were available to us were Perturb and Observe, Incremental Conductance, Constant Voltage, and Load I of V Maximization. Perturb and observe was not efficient because it produces an oscillating power output due to the fact that its tracking method does not know that it has found the maximum power point and so it keeps on oscillating around it. Incremental conductance tracks the maximum power point effectively with no oscillations and can also track it in fast changing conditions. Constant voltage results in some loss of energy because it disconnects its power source to measure the open circuit voltage which it uses in its algorithm.

The technique that we decided to utilize is the load I or V maximization technique because it was easily applicable to our system. This technique calculates the power coming in, determines the voltage of the load and then calculates the needed current to equal the power coming in and feeds control information into the DC-DC converter to match the new voltage with the new current. This allows for a close approximation of output power to input power. Because of this technique the charge controller circuit will no longer use the constant current and constant voltage stages. The voltage and current will always be fluctuating but the energy transfer will be much more efficient. These methods are a more effective use of time because the efficiency of a turbine to convert wind to mechanical energy is less than 50%, 59% maximum. The maximum power point tracking calculations used in our system can be seen in the charge controller design section. We tried to output 95% of the input power but that can be changed for a better efficiency rating.

To test the MPPT we gave it a constant input voltage, variable input current, and variable output voltage. The tracker will determine the current that needs to be pushed into the variable output voltage to produce 95% power efficiency. 100% power efficiency is not used because the algorithm will recalculate the DC-DC converter to equal the output voltage every time. This causes a problem because you cannot push current unless one

voltage is higher than the other. 99% is obviously still too close so we searched on line for charge controller efficiencies and they ranged from 94% to 97% so we chose a middle ground. The test circuit uses a shunt resistor as a current sensor which will be added to the charge controller circuit permanently.

The objective for the inverter was to be able to convert DC power to a household AC power source and power small electronics. The inverter must convert a 24VDC battery bank to 60Hz AC and match a pure sine wave as well as possible. Our research showed that there are many different types of inverters. The easiest and cheapest inverter to design is the square wave inverter although it is not pure sine wave it works with some AC electronics. A better designed inverter is the modified sine wave inverter which is closer to a pure sine wave than the square wave and can use more AC electronics than the latter. The pure sine wave inverter generates a pure sine wave at 60Hz. This design is very hard to because there are harmonics that have to be filter out.

A pure sine wave inverter can be designed for a 12VDC system using a NE555 Timer that is in mono-stable mode and uses it as a low frequency oscillator. This design, shown in figure X, takes 12VDC and converts it to 120VAC. Because we are using a 24V DC system we first have to use a DC-DC converter to step- down the voltage. Since we designed one earlier we will use the same design this time. In the design two LT1217 operational amplifiers are used to generate signal for the system. They produce a square wave output and a sine wave output. The output of the operational amplifiers feed into the NE555 Timer. The square wave input activates the pulse width modulation. The triangle wave modulates the signal width of the output square waves. The output generates a sine pulse wave modulated signal from the 555 Timer. You can see this in Figure X. Figure X shows the second stage of the pure sine wave inverter.

The battery is connected to the second stage of the NE555 circuit. In this stage the signal that is produced by the NE555 modifies the battery signal that is driven into the transformer to produce the output sine wave that is desired. In state two the pulse width modulation signal that is produced by the NE555 timer is received by two 2N3019 NPN transistors at their base. The transistors switch the battery voltage into the transformer and the pulse width modified waveform augments the signal according to its duty cycles. The other two transistors, 2N5041 PNP, make sure that Q1 and Q2 cause the transformer to output one complete AC cycle with two halves of the modulated pulses. The frequency is determined by the 150K preset that is attached to the operational amplifiers. The amplitude can be modified by a 1M preset that is also near the operational amplifiers. Because the voltage was stepped down from 24VDC to 12VDC the new AC signal has to be stepped up from 120VAC to 240VAC. This can be done with a transformer with the right turns ratio. The block diagram of the inverter shows that the input is a dialed down DC power and its output to the transformer is AC power. With this the battery system can now power small electrical appliances that require AC power.

The data logging mechanism of Intellaturbine will record data at a rate according to some specific interval, perhaps one data log every elapsed 5 minutes of time after the point an SD card is inserted and verified. The data being logged by Intellaturbine by the Arduino

Duemilanove and Data Logging Shield will consist of four data parameters important to analyzing the performance of the design:

- 1) The accompanying time stamp detailing the present calendar date at the moment the data was logged into the SD card, in MM/DD/YY format, followed by a space, and the exact time of day in which the moment the data was logged, in 24-hour HH/MM/SS format.
- 2) The prevailing wind speed value, in units of miles per hour. This value is the result of the averaging formula involving the number of pulses recorded by the wind speed sensor divided by the recording time. The data logger will begin to record pulses from the sensor the minute before the 5-minute mark when the data will be logged and written to the SD.
- 3) The prevailing wind direction value taken from ADC1, in units of degrees of deviation from the centered direction of the wind turbine assembly. The data logger will perform a similar averaging formula in the minute before the data logging interval, recording and summing the measured wind direction angles from the sensor every 5 seconds. After 12 additions the resulting value is divided by 12 and logged.
- 4) The average current value taken from ADC2 in units of mili-Amperes, detected by the current sensor circuit. The data will be recorded simultaneously with the wind direction and be subject to the same averaging formula, meaning only the 12 measurements during the minute before the data logging interval are recorded, summed and averaged.
- 5) The average voltage value taken from ADC3 in units of Volts, detected by the voltage sensor circuit. The data will be recorded simultaneously with the wind direction and current parameters. The same averaging formula will also be used.

These values are written to a data string and delimited by commas. Assuming the time of the data logging interval has arrived, the routine will print the data string representing a single line of data into a .csv (comma-separated values) file on the inserted SD card, followed by a new line for the next data logging interval. The order in which the data is logged will produce lines of plain text data in the .csv file that look something like the following:

```
(time stamp, wind speed, direction (degrees), current (mA), voltage (V) )  
6/27/12 15:33:27, 5.52, 23.11, 357.76, 24.79  
6/27/12 15:38:28, 3.14, 27.56, 223.42, 24.54  
6/27/12 15:43:29, 4.36, 26.98, 304.53, 24.21  
6/27/12 15:48:31, 2.55, 24.49, 150.12, 23.89
```

This .csv file from the SD can typically be opened with a spreadsheet program on any modern operating system, and then at that point manipulated as the user desires, be it for charts or graphs relating any two of the parameters together.

# 7 Testing

## 7.1 Introduction to Testing

Testing is an integral aspect of any design and implementation. Ensuring a project meets its design requirements is not only important to demonstrate that it works but also make sure safety requirements are adhered to. For testing, the project will be divided into several segments such as: wind turbine, charge controller, voltage regulators, bridge rectifier, data storage, data display and wind speed/tracking capabilities. Each segment will be tested separately and then combined for an overall test in real world and simulated conditions.

## 7.2 Bridge Rectifier

Testing the full-wave bridge rectifier will be fairly easy and straight forward. It will be tested independently in a lab using a Function Generator and an Oscilloscope. The range of inputs for the rectifier will come from the spec sheet of the TGL-500 turbine. The team will vary through this range of voltage input, verifying that the signal is rectified throughout. Safety will be a major concern in testing this design, whether in a laboratory or real world conditions. A check list will be developed for this and every segment being tested; this will not only ensure functionality but that all safety procedures are being followed.

Full-wave Bridge Rectifier Checklist:

- Connect rectifier to Function Generator and Oscilloscope.
- Double check connections of circuitry and equipment.
- Vary Function Generator through range (being extremely careful because of high voltage) and record findings on Oscilloscope.
- Verify rectification throughout range.
- Power down equipment before making any disconnections.

## 7.3 Wind Turbine

An accurate base line test of the wind turbine is essential to know where and when the correct power output level is being attained. This could prove difficult for the team as a real world situation will not lend itself kindly to this. Therefore, it was decided that a rotor for example an electric drill with variable speed control will be used to base line the turbine independently, matching it to the manufactures specification. Below is Figure 46, a chart from the manufacturer depicting the turbine's output at various RPMs:

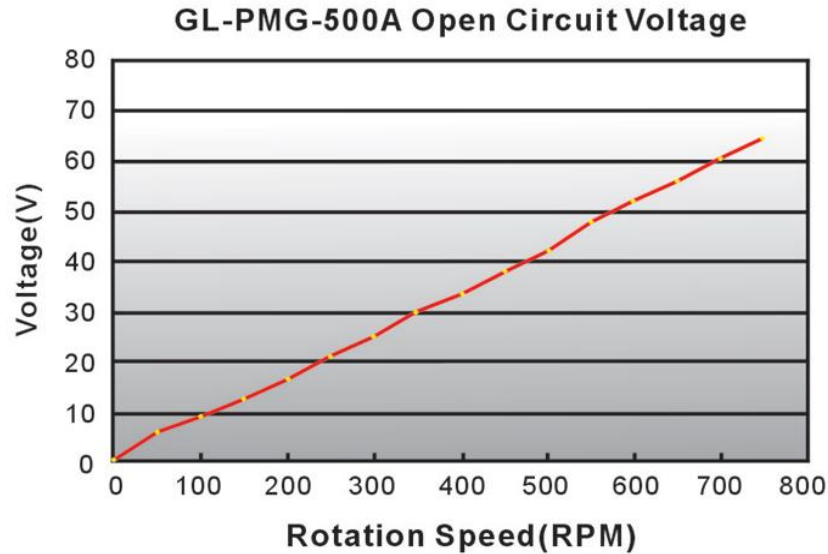
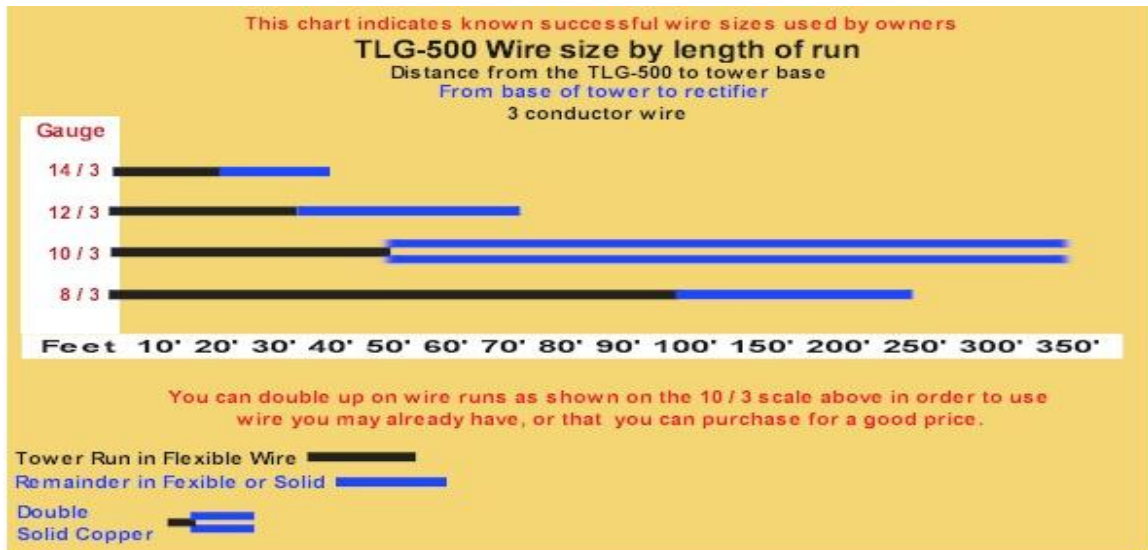

**Figure 46: Voltage Output vs. RPM**

This data will be captured using multimeters and oscilloscopes.

After generating this base line it is still important to know how the turbine will perform completely assembled (blades mounted) and in a real world situation. The best way to achieve this is to test the turbine where an un-obstructive wind flow can be realized. The perfect location for this would be an open field such as a local airport or one of UCF's sporting fields. As with any correctly done testing scenario the conditions under which the results are generated must be recorded. Therefore, when the turbines are taken to an open field, not only will the power output be measured but also wind speed and direction. Each unit needs a start up speed of 5 mph to break and roll and should have the targeted output of 500 watts at around 35 mph depending on wind density. The annual wind speed average (available from many weather tracking websites) for Orlando will be studied in order to decide the appropriate time and place to conduct the real world test.

As can be seen from the chart above the voltage output of this unit is large and so too is the expected current output. Hence safety precautions must be made and adhered to. Only correct instrumentation capable of handling the high outputs must be used. All connections must be made and double checked when stationary before attempting any test. The mechanical structure must be sound not only to prevent personnel injury but also equipment. The correct gauge wire must be used not only for safety reasons but also to prevent losses due to resistance. Below is Figure 47, a chart indicating correct wire sizes and the distance they may be used.



**Figure 47: Wire Size Chart**  
(Permission Pending)

Pre-caution must also be taken to ensure the units never over speed as this could lead to equipment failure and/or personnel injury.

With this base line generated the team will now know two important factors: are the units working and do they meet the design specifications. The following is a checklist for base lining the turbines:

- Verify turbines are stationary.
- Check mechanical structure and electrical circuitry.
- Connect measuring equipment (measuring open voltage first).
- Allow turbine to rotate freely in real world environment.
- Record voltage output and wind speed.
- Verify turbines are stationary.
- Reconfigure for short circuit current test.
- Allow turbine to rotate freely in real world environment.
- Record current output and wind speed.
- Verify turbines are stationary before disconnecting.
- Connect turbines to load (batteries) along with measuring equipment.
- Allow turbine to rotate freely in real world environment.
- Measure and record current and voltage output and wind speed.
- Verify turbines are stationary before disconnecting.

## 7.4 Voltage Regulators

### 7.4.1 Buck Converter

Even though a Buck Converter is a common, regularly used design it is still important for the team to individually test their design. Theoretically the simulations of the design should yield the correct results. However, since this prototype will be spec'd and built by the team checking for the correct voltage output is paramount for protection not only for other components of the overall design but the team member as well. Another aspect which will not be revealed in simulations is the temperature of the circuit. This has to be closely monitored to prevent any overheating in the design. Below is the checklist for testing the buck converter:

- Verify variable DC power supply is off
- Connect converter to variable DC power supply and multimeter
- Double check connections of circuitry and equipment.
- Power on variable DC power supply and multimeter
- Vary power supply through expected DC voltage range
- Check circuit for temperature
- Measure and record DC output throughout range of inputs
- Power off equipment before disconnecting

## 7.5 Complete Power Generation System

At this junction, all components up to the storage device (DC batteries) should have been tested individually and confirmed to be working as per specification. These include the wind turbine, rectifier, voltage regulator and charge controller. These components will now be connected together for a final overall check before connecting them to the batteries. To ensure there has been no deviation from the expected output of the system thus far, measurable, repeatable test must be performed. Hence real world conditions will not be used here but rather an electric motor with measurable and variable speed control. Another advantage of using an electric motor such as a drill here is the start up/shut down time of the test. This will be the first time the components are functioning together and therefore monitoring for heat and circuit complications are extremely necessary.

Complete power generation system checklist:

- Connect design components together
- Connect data acquisition equipment (multimeter, RPM sensor )
- Connect drill to turbine shaft

- Double check connections of circuitry and equipment.
- Vary drill speed
- Check circuit for temperature
- Measure and record data
- Power down all equipment before making any disconnections

## 7.6 Sensors

To test the performance of the voltage and current sensing subsystems as they will appear in the design, the components used in the circuit will require fabrication before a PCB can be tested and verified. However, the circuits are simple enough to model via a breadboard and basic electronics lab equipment. The voltage and current sensor and signal conditioning circuits that follow them require both the signal generator and an oscilloscope that can perform Fast Fourier Transform on the signal waveform to produce a frequency response waveform. This way we can measure not only the resulting output voltage level from the circuit, but whether our low pass filter is exhibiting behavior becoming of a low pass filter. To map the frequency response, we can connect the analog input lead of the oscilloscope at the point between the output of the current or voltage sensor (which we will replace with a DC signal generator for purposes of this test) and the input of the active anti-aliasing filter. The analog output lead on the oscilloscope can safely connect to the output of the filter. Using the Fast Fourier Transform, we can record at which point the gain of the filter begins to attenuate, how steeply it does so in dB per decade, and at what point of frequency the filter exhibits peak gain.

To properly test the actual current or voltage sensors and determine whether the circuits give correct readings, we may use a variable DC power supply to either run a test current into the current-sensing resistor and – in doing so – run a test voltage into the high-side current monitor to measure the A-V proportionality of the device, or supply a high DC voltage simulating that of our battery system into our voltage divider circuit and record the resulting output voltage, quantifying and comparing these values with our predicted values to gain a better understanding of the performance and error ratio of our circuit components. With this knowledge we may make the necessary adjustments to our analog signal sensor subsystems so the measurements in the digital realm are more accurate.

## 7.7 Battery Bank

The more accurate way to test the lead acid battery would be to use a hydrometer to measure its specific gravity but a hydrometer may not be readily available. Therefore, other steps may be taken to test the battery.

- 1) The first step is to charge the battery system to its full capacity of 25.68V.

- 2) Next the topping charge has to be removed by letting it rest for several hours or discharging it for several minutes using an automotive bulb.
- 3) Then measure the voltage at 100% and discharge it at a max possible current, maybe 2A, at the charging voltage, 27V and time how long it takes to discharge.
- 4) Connect the battery to the battery monitoring circuitry. The LEDs should light up immediately indicating that the battery is at full capacity by lighting up red, yellow and green.
- 5) As the battery discharges the LEDs should turn off. As it loses 25% of its charge it the green LED should turn off leaving the red and two yellow LEDs lite. When another 25 % of its charge is done then the first yellow LED will turn off. At another 25% the second LED will turn off.
- 6) When the last yellow LED turns off start recharging the battery. This show the battery is working correctly and the monitoring system is functional.

## 7.8 Charge Controller

The charge controller should be tested in the on state and the off state. That is when the battery is not charged and fully charged. To test the charge controller it must receive an input voltage of 0-27VDC. When the MOSFET M1 is on the output current should be around 7.4A and the source voltage is more than 1V larger than the battery system. This is also the current going into the NMOS which can be calculated by building the charge controller circuit, shorting circuiting the battery bank, and measuring the current through the short. When the voltage in is greater than the battery Q2 is off and at least 5V is produced at the gate of the M1. The LED will not light up because Q1 is off due to the fact that Q2 is producing a voltage at the gate node of M1. Now test the off state of the charge controller by setting the voltages equal. Although the voltage in the gate is zero the voltage in that node will read 6V. The 6V zener diode causes this voltage in the analysis so instead of looking for a very small voltage just check to see if the voltage is equal to that of the zener diode to determine if M1 is on or off. To turn M1 off the battery voltage must be about 1V less than the source voltage. When the two voltages are close the gate voltage across resistor R5 is less than 0.7 so the MOSFET should be off. When the FET is off the zener diode D3 shorts the gate voltage and allows current to flow through the LEDs to notify full charge.

- 1) Make sure the battery is not fully charged.
- 2) Build the circuit in figure X but do turn on the source voltage.
- 3) Connect an ammeter to in the battery to measure the current going in.
- 4) Connect a voltage source to the circuit, turn it on, and set it to 5V.

- 5) The ammeter should read about 1mA coming from the battery.
- 6) Measure the voltage going into the gate of the MOSFET it should be 6V. This means that the N-FET is off and voltage being measured is the zener diode voltage and there is no charging current flowing through the battery.
- 7) Now turn the source voltage up until it is larger than the battery voltage.
- 8) Measure the current flowing into the battery. It should be about 7A.
- 9) Measure the voltage at the gate of the N-FET; it should be about 4V indicating the transistor is on and allowing current to flow through the transistor.

## 7.8.1 Maximum Power Point Tracking

Before testing of the maximum power point tracker can begin first the DC-DC converter and the charge controller must be connected and working. Although, testing the maximum power point tracker will only need a current source and battery voltage. The MPPT will assume a set voltage and will calculate the input power. The algorithm will calculate the input current needed to output 95% of the input power. Once that is done it should adjust the DC-DC converter to input the 95% current into the battery. The input current and the input voltage should still read 100% of the input power. The output power should be equal to 95% of the power input. Errors in calculations can be adjusted by changing the efficiency coefficient, 0.95. Because this is for testing you should increase the coefficient to try to output more power. Try getting it as close as possible to 100% but do not try to achieve full power transfer as that is impossible. For this test procedure the MPPT algorithm will be set to variables that we will change throughout testing. A current source will provide variable current for the battery and the MPPT will assume an input voltage of 24V and variable output voltage will be substituted for the for the battery system. The algorithm will know the battery voltage and it will receive the value of the current measured by a shunt resistor. Figure 48 has a good representation of the test circuit.

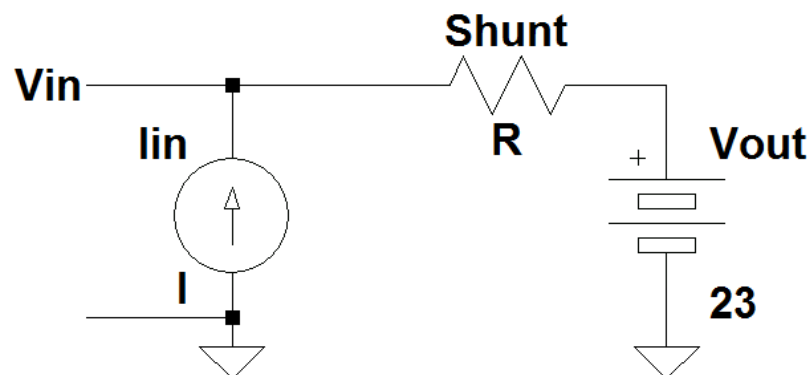

**Figure 48: MPPT test circuit.**

- 1) Set  $V_{OUT}$  equal to 23V.  $V_{IN}$  is automatically 24V
- 2) Set the current source to be 5A. The MPPT should output  $P_{in}$  as 120W and then compute 95% of that which is 114W. Now it should calculate the  $I_{in}$  as 4.95A and  $V_{in}$  is 24.2
- 3) Use the MPPT equations from the design section to compute the values the algorithm should put out.
- 4) Keep  $V_{IN}$  at 24V and change  $V_{OUT}$  and  $I_{IN}$  and check the MPPT for accuracy. Note that  $V_{OUT} = V_B$ .
- 5) Calculate the predicted values and the check them against the experiment.
- 6) Change the efficiency coefficient if to see if you have better results.

## 7.9 Inverter

A DC power generator and an oscilloscope are needed to test the inverter. Since the inverter system includes the step down DC-DC converter, inverter, and transformer as shown in the inverter block diagram in Figure X, each component will be test in this section. The first test will be the DC-DC converter. In the earlier section of this system a DC-DC converter is used to step down the wind turbine voltage and implement MPPT. That same design will be used but only to step down the system to 12V. The current coming from the converter will be high so the components will have to have a high tolerance. Use the same testing procedures for the first converter. After the converter is in a sufficient operating mode the next circuit to be tested the inverter.

- 1) Make sure the circuit is connected properly and that the components can handle the operating currents and voltages. The wires should be at least 2AWG depending on the power that was transferred from the converter.
- 2) The next step is to build the pulse width modulation circuit which is stage 1 of the inverter circuit. Set up the circuit with the 555 Timer as shown in Figure X.
- 3) Now connect the oscilloscope to the output of the 555 Timer at pin #3.
- 4) Connect channel 1 of the oscilloscope to pin #3 and connect channel 2 to pin #2 of the 555 Timer.
- 5) Turn on the DC power supply and set it to 12V.
- 6) Attach the supply voltage to pin #8 of the 555 Timer to provide power to the IC.
- 7) Now turn on the oscilloscope to observer the square wave and the PWM output. Try adjusting the amplitude and frequency to see how the figure changes.

- 8) Turn off the oscilloscope and remove the DC source and disconnect channel 1 from the 555 Timer pin #3. Now carefully assemble stage 2 of the inverter circuit.
- 9) Connect the channel 1 of the oscilloscope to the AC output part of the stage 2 inverter circuit shown in Figure X.
- 10) Connect the positive and negative voltages from the converter to the battery plus and minus nodes shown in Figure X.
- 11) Connect the stage 1 inverter circuit to stage 2. That is, connect the PWM and the square wave input.
- 12) Turn on the oscilloscope on and the output should be a sinusoidal output of 120VAC.

## **7.10 Data Logging**

### **7.10.1 Microcontroller**

To connect the ArduinoDuemilanove Board into a PC for development and debugging, a standard A-to-B USB cable is supported by the device and should be used. To obtain the Arduino Development Environment, it must be downloaded from the Arduino website at the URL <http://arduino.cc/en/Main/Software>, and the latest version (v 1.0) should be chosen. After this is accomplished, the board must be connected to the USB port of any personal computer or laptop, upon which Windows will recognize the device and attempt to install the software driver for it, and succeed. The Arduino IDE can now be used to communicate with the Duemilanove. If a test program is available within the bootloader located in the flash memory of the chip, this routine can be run to ensure the Arduino board is configured for normal operation.

Also available on the Arduino website are example programs that perform various simple functions, the real purpose of them being to help us become more familiar with both the Atmel processor architecture and the Arduino development language. Hopefully after this familiarity is attained we may proceed with the coding of the main data logging routine and subroutine. Of course, the data logging shield and SD libraries we will obtain would have to be tested as well with an actual SD card. Theoretically upon plugging the Arduino + Data Logging Shield into a PC, we could access the data on the FAT32-formatted SD card from a 'mass storage device' as displayed by Windows, but the Arduino model we will be using may not support such a functionality.

## 7.10.2 Software

To test whether our code routines pertaining to data logging work properly, i.e., the SD card gets written with the correct data measurements in the right format, we can hook up signal generators to the microcontroller inputs that would otherwise be measuring the wind speed, direction, current and voltage, and attempt to verify the accuracy of this data alone. Rather than print the data to the SD card in this case, we may write code to allow for the data to be printed within the environment so every time we run it, the data measurements at that time will be clearly shown. For the case of wind speed, a square wave generator should work for the digital input pin, simulating the appearance of a pulse from the sensor that results in the JK flip-flop being set. Simple sine wave generators will be used to test the current, voltage, and wind direction, the generator output leading into each analog input pin separately. Using this method we may also try to pin down the proportionality constants used by the program to translate the voltage signal coming from the current, voltage, and angle sensors into measurements of the parameters themselves – this will serve to calibrate the sensor inputs into a range of measurement that both makes sense for the program code and does not endanger the microcontroller unit with a voltage signal that may prove to be above its specified, prescribed limits.

The logic of the code must also be tested. In doing so we will simply set the data logging interval to print data to the screen every 5 minutes, and begin to take measurements the minute before this time, once every 5 seconds. In printing this data to the screen as the measurements are being taken we can decide whether the program is following our prescribed logic pattern, takes sensible parameter measurements, and whether the averaging formula for the parameters computed at the data logging interval serves its intended purpose. Also, the format of the time stamp is an important consideration as well and should be observed to decide whether it aids or impedes understanding of the data when converted to text and thus a spreadsheet format. For example, a simple time stamp with numbers and slashes for the date and colons for the time is preferable to one that attempts to write names of months. All of this should be made possible in a development and debugging sense due to the Arduino IDE having support for the device to be connected to a computer via a USB cable.

## 7.11 LCD Display

### 7.11.1 Prototype

The LCD display system prototype was designed and tested using a conventional breadboard and an Atmel microcontroller. Below is Table 14, a list of the parts used in the prototype design. Figure 49 is a photograph of our current prototype.

Part	Cost	Number of used
Breadboard	\$10	1
Atmel Microcontroller	\$1.5	1
Hitachi HD44780	\$3	1
Capacitors	\$1.25	1
Resistors	\$2	4
7805 Voltage regulator	\$0	1
9V battery pack	\$4	1
USB to Serial cable	\$0	1
General purpose switch	\$0	2
Total Cost and Parts	\$21.75	13

**Table 14: LCD Prototype Parts List**

The LCD and microcontroller pin out from the prototype design will match the original PCB design. Below is the figure of the circuit design.

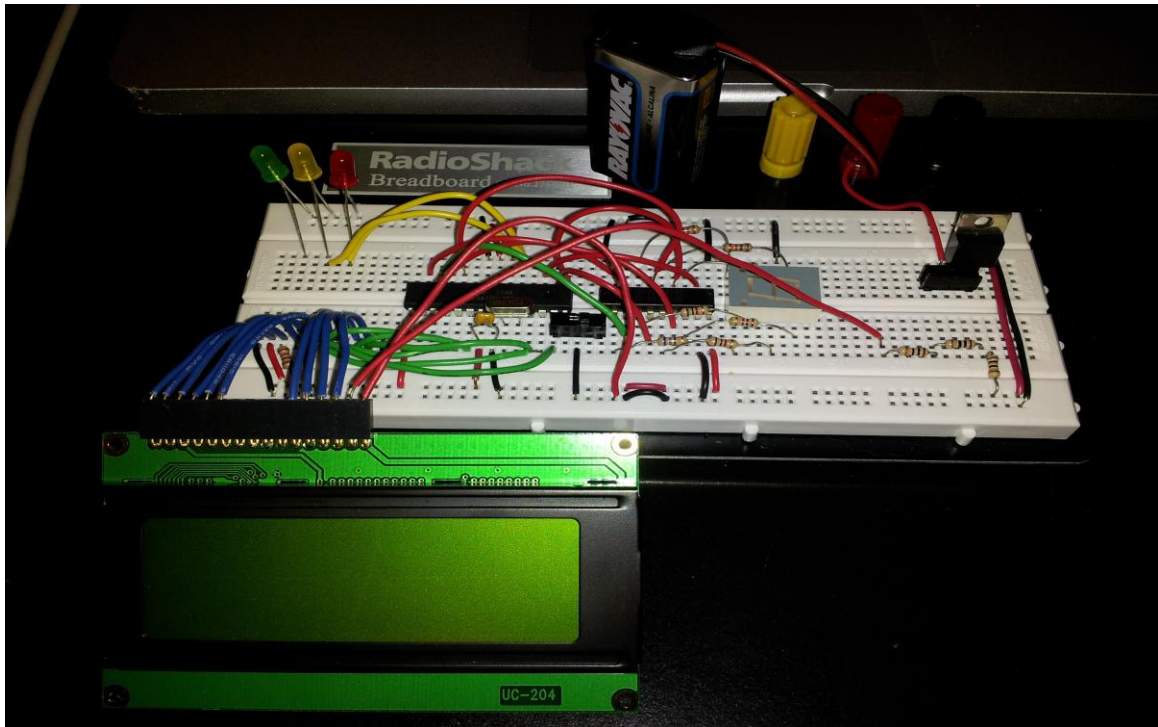

**Figure 49: LCD Display Circuit Prototype**

## 7.11.2 Testing

1. You will need to cut and strip 6 short wires for this procedure.
2. Using the wires, connect pin 7 of the MCU to the red (+5V) rail of the breadboard.
3. Connect pin 8 of the microcontroller to the blue (GND) rail.

4. Connect pins 20 and 21 of the microcontroller to the +5 rail.
5. Connect pin 22 of the microcontroller to the GND rail.
6. Connect the RESET pin (pin 1) to the +5V rail.
7. Connect the crystal oscillator to pins 9 and 10 on the MCU.
8. Connect LCD pin 1 to GND.
9. Connect LCD pin 2 to +5V.
10. Connect LCD pin 3 to the contrast resistor.
11. Connect LCD pin 4 to MCU pin 13.
12. Connect LCD pin 5 to GND.
13. Connect LCD pin 6 to MCU pin 12.
14. Connect LCD pin 11 to MCU pin 4.
15. Connect LCD pin 12 to MCU pin 5.
16. Connect LCD pin 13 to MCU pin 6.
17. Connect LCD pin 14 to MCU pin 11.

**Symptom 1:** Voltage regulator gets hot. No activity on the LCD.

**Diagnosis:** You likely flipped VCC and ground at some point. Double-check the pin-out on this page against your circuit.

**Symptom 2:** First and third row of LCD turns on, but no characters are displayed.

**Diagnosis:** This means the LCD is getting power, but not getting any data it recognizes. One of the wires between the MCU and the LCD is loose or in the wrong place.

**Symptom 3:** Everything looks right, but nothing comes on the LCD.

**Diagnosis:** It is possible you have the wrong contrast resistor for the LCD. You want a 1K-ohm resistor, which means color bands brown, black, and red. Remember brown=1, black=0, red=2, so  $10 \times 10^2 = 1000$  ohms

**Symptom 4:** Everything looks right, and you checked the contrast resistor but nothing comes on the LCD.

**Diagnosis:** Although it is rare, your battery might be dead from the factory. Use a multi-meter to check the voltage between the battery leads, which should be very close to 9V. Also check the voltage between your power rails, which should be very close to 5V.

# 8 Administrative

## 8.1 Milestones

The tentative schedule is to have all research and design completed in the first academic semester of Senior Design 1 and assembly and testing in the second semester Senior Design 2. The project will be broken into five steps: Research, Design, Parts Acquisition, Assembly, and testing. A detailed breakdown can be seen in Figure 50 below.

		15-Jan	1-Feb	15-Feb	1-Mar	15-Mar	1-Apr	15-Apr	1-May	15-May	1-Jun	15-Jun	1-Jul	15-Jul	1-Aug
Research	Wind Turbine	█													
	Battery		█	█	█	█	█								
	Microcontrollers		█	█	█	█	█								
	Charge Controller	█	█	█	█	█									
	Maximum Power Point Tracking		█	█	█	█	█								
	Power Inverters		█	█	█	█	█								
	Displays		█	█	█	█	█								
	Voltage Regulators		█	█	█	█	█								
	Data Acquisition		█	█	█	█	█								
	Power Diversion	█	█	█	█	█									
	Wind Direction and Speed Control	█	█	█	█	█									
Design	Wind Turbine			█	█	█	█	█							
	Battery			█	█	█	█	█							
	Microcontrollers			█	█	█	█	█							
	Charge Controller			█	█	█	█	█	█						
	Maximum Power Point Tracking			█	█	█	█	█							
	Power Inverters			█	█	█	█	█							
	Displays			█	█	█	█	█							
	Voltage Regulators			█	█	█	█	█							
	Data Acquisition			█	█	█	█	█							
	Power Diversion			█	█	█	█	█							
	Wind Direction and Speed Control			█	█	█	█	█							
Parts Acquisition	Wind Turbine							█	█	█					
	Battery							█	█	█	█				
	Microcontrollers							█	█	█	█				
	Charge Controller							█	█	█	█				
	Maximum Power Point Tracking							█	█	█	█				
	Power Inverters							█	█	█	█				
	Displays							█	█	█	█				
	Voltage Regulators							█	█	█	█				
	Data Acquisition							█	█	█	█				
	Power Diversion							█	█	█	█				
	Wind Direction and Speed Control							█	█	█	█				
Assembly	Wind Turbine										█	█	█		
	Battery										█	█	█		
	Microcontrollers										█	█	█		
	Charge Controller										█	█	█		
	Maximum Power Point Tracking										█	█	█		
	Power Inverters										█	█	█		
	Displays										█	█	█		
	Voltage Regulators										█	█	█		
	Data Acquisition										█	█	█		
	Power Diversion										█	█	█		
	Wind Direction and Speed Control										█	█	█		
Testing	Wind Turbine												█	█	█
	Battery												█	█	█
	Microcontrollers												█	█	█
	Charge Controller												█	█	█
	Maximum Power Point Tracking												█	█	█
	Power Inverters												█	█	█
	Displays												█	█	█
	Voltage Regulators												█	█	█
	Data Acquisition												█	█	█
	Power Diversion												█	█	█
	Wind Direction and Speed Control												█	█	█

**Figure 50: Milestone Tentative Schedule**

## 8.2 Budget

The major components for Intellaturbine will be funded by our sponsor Shaun Dunbar, who will retain ownership of said components. A few items have been added to our budget making the final estimate higher than the original. The new estimate is still fairly close to the original and the team will be working to keep cost down by trying to acquire free samples or a reduction in price from companies. Items not covered by our sponsor will be the responsibility of the team members. The chart below, Table xx, shows a revised version of our budget reflecting the new total.

<b>BUDGET</b>	
<b>Part</b>	<b>Price</b>
Alternator (quantity=2)	\$1,570.00
10 blade system (quantity=2)	\$498.00
Batteries (quantity=4)	\$1,400.00
PCB	\$100.00
LCD Screen	\$30.00
MSP 430	\$10.00
DC Meters	\$40.00
AC-DC Conversion Parts	\$130.00
Base & Shaft	\$150.00
DC Motors	\$50.00
Wires	\$50.00
Wire Connectors	\$30.00
Sensors	\$50.00
Miscellaneous Parts	\$150.00
Total	\$4,258.00

**Table 15: Itemized Budget**

## 8.3 Final Plans

The final plan for the device would be to turn over a working prototype to Mr. Dunbar our sponsor. It was Mr. Dunbar's intent with the aid of one of our team members to build his own wind power generator and since this coincides with our senior design project, he graciously agreed to sponsor our project. It is Intellaturbine's wish that their design functions to specification and is truly able to remove and sustain an average household from the power grid. We would also like to thank Mr. Dunbar for enabling us to design and construct this project.

## 8.4 Project Summary

To summarize the final design of the project we will take a look at the different segments, how they interact with each other and then the final outcome of the design.

We will start with the power generation segment, the wind turbine. Our target input for this design is 1000 watts at 24 VDC. Two TLG-500 wind turbines were task with providing this input. Each of these turbines is capable of producing 500 watts at 24 VDC. The TLG-500 is also capable of producing maximum output at low wind speeds of around 28 to 32 MPH depending on wind density. The turbines will generate three phase AC voltage and will be kept that way until it arrives at the battery bank, thereby reducing losses by trying to transport DC. The final structure that the two turbines will be mounted on will be fairly large and has to be positioned where it has unobstructed wind flow.

Once the generated power arrives at the battery bank it will be rectified to produce DC voltage. The rectified voltage will then be regulated and passed on to the charge controller. The charge controller will be tasked with charging the battery bank at the proper charge cycle (float, absorption, and bulk) ensuring the batteries are kept within specification. Over or under charging the batteries will drastically reduce their life span. The system will utilize four 6 VDC batteries connected in series to yield 24 VDC.

The next segment to be summarized will be Intellaturbine “smart” design. The system will be controlled by microcontrollers doing various things. The system will display via screens the inputs and outputs generated by the system. It will also display other important information such as wind speed, battery status, and turbine shaft speed in RPM. The design will also incorporated data logging capabilities so that the own can track the performance of the system and there by using this information to improve efficiency.

The design will also have built in safe guards such as power diversion in the event the batteries are fully charged and the turbines are still producing. It will also account for the opposite scenario, the batteries need charging and there is no output from the turbine. Here the system will allow for an alternate power source to be used, such as reconnection to the power grid or gasoline generator.

The final segment to be looked at here is how utilize the energy that was generated and stored. Our stored energy is now in the form of 24 VDC, the average household is 120 VAC. Here an inverter will be used to convert the power back to AC making it suitable for consumption.

The block diagram in Figure 51 below illustrates how all the segments summarized here are interfaced together.

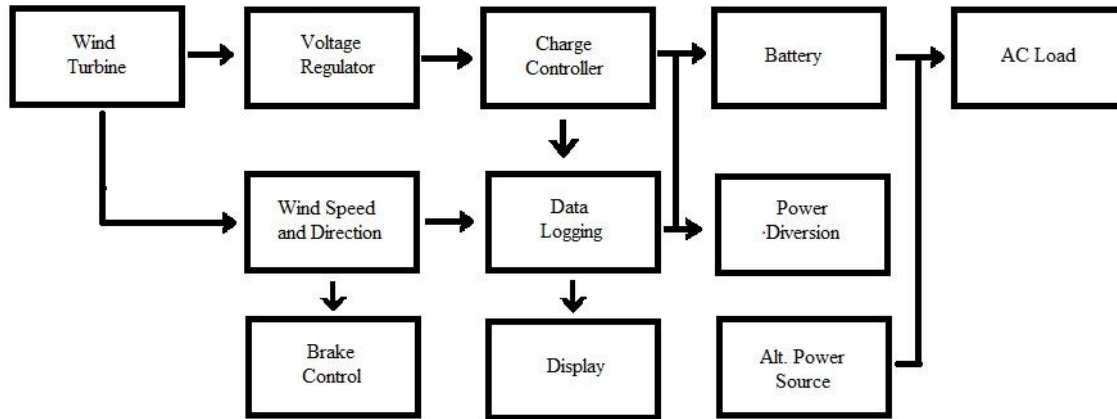

**Figure 51: Main Segments of the Design**

## 8.5 Conclusion

It was the intent of Intellaturbine to research and design an intelligent, alternative power source capable of sustaining the average household. Valuable experience was gained by all team members as we had to explore several fields of engineering to design the overall project. The project was composed of mainly the electrical and computer engineering disciplines, but there was also a mechanical aspect relating to the turbines, as well as procurement and budgeting for all the parts needed.

The team had steep learning curve during the research segment of this design as we were overwhelmed with new technology and trying to identify compatible components. However with the knowledge and systematic approach that we learned as engineering students, the team was able to understand the concepts presented to them and apply it to designing our project to specification.

The design aspect of this project proved to be challenging. Unlike the classroom setting where students are usually taught principles or given a question with a definite answer, designing a project in the real world is some what different. First of all you are usually given the answer (project specification) and have to work backwards to come up with the design. This makes it difficult because it's not just a case of solving a mathematical equation but finding parts and equipment meeting the design requirement that are also compatible with each other.

The last and probably most important segment of the senior design project is testing. The testing section not only demonstrates that the design works but also that it is within specification. Since this project is unique to us the team had to come up with its own series of repeatable test. Testing each segment separately before combining and testing the overall unit makes troubleshooting simpler. Multiple testing methods had to be developed because not only were we testing in the ever changing real world, tolerances in the parts and design had to be accounted for too.

Designing this project and building it next semester will be good hands on experience for the team. Not only will they be using engineering concepts but time management, team work, documentation, and financial budgeting skills as well. It should be noted that this design is subject to change as the procurement of parts and testing begins.

# 9 Appendices

## 9.1 Bibliography

Caleb Engineering LLC, “Data Logger”

[Online] Available: <http://www.calebengineering.com/data-logger.html>

Caleb Engineering LLC, “Current Sensor”

[Online] Available: <http://www.calebengineering.com/current-sensor.html>

Maxim Integrated Products, “High-Side Current-Sense Measurement: Circuits and Principles”

[Online] Available: <http://www.maxim-ic.com/app-notes/index.mvp/id/746>

Electronics Tutorials, “Op-amp Filter – the Active Low-pass Filter”

[Online] Available: [http://www.electronics-tutorials.ws/filter/filter\\_5.html](http://www.electronics-tutorials.ws/filter/filter_5.html)

DharmaniTech, “Design with Microcontrollers: SD/SDHC Card Interfacing with Atmega8/32”

[Online] Available: <http://www.dharmanitech.com/2009/01/sd-card-interfacing-with-atmega8-fat32.html>

Microchip Technology Inc., “8-bit PIC® Microcontrollers”

[Online] Available: [http://www.microchip.com/pagehandler/en\\_us/family/8bit/](http://www.microchip.com/pagehandler/en_us/family/8bit/)

Texas Instruments, “Ultra-Low Power Value Products”

[Online] Available:

<http://focus.ti.com/paramsearch/docs/parametricsearch.tsp?familyId=1937&sectionId=95&tabId=2662&family=mcu>

Atmel Corporation, “megaAVR Microcontrollers”

[Online] Available: <http://www.atmel.com/products/microcontrollers/avr/megaavr.aspx>

Arduino, “Arduino Board Duemilanove”

[Online] Available: <http://arduino.cc/en/Main/arduinoBoardDuemilanove>

Arduino, “Arduino – FAQ”

[Online] Available: <http://arduino.cc/en/Main/FAQ>

Adafruit Industries, “Data Logger Shield for Arduino”

[Online] Available: <http://www.ladyada.net/make/logshield/index.html>

Sparkfun Electronics, “Logger Comparison”

[Online] Available: <https://github.com/sparkfun/OpenLog/wiki/Logger-Comparison>

Adafruit Industries, “Arduino SD Library”

[Online] Available: <https://github.com/adafruit/SD>

WindSolarEnergy, “Wind Speed Map”

[Online] Available: <http://www.windsolarenergy.org/map-of-best-locations-for-wind-power.htm>

"HowStuffWorks "Modern Wind-power Technology" "*HowStuffWorks "Science"*

HowStuffWorks.com. Web. 13 Nov. 2011.

<<http://science.howstuffworks.com/environmental/green-science/wind-power2.htm>>.

"Wind Electricity Basics." *Affordable Solar*. Home Power Magazine. Web. 10 Oct. 2011.

<<http://www.homepower.com/basics/wind/>>.

"Power Inverter Frequently Asked Questions (FAQ)." *Power Inverters - 12V Inverters - DC to AC*

*Power Inverters*. Web. 3 Dec. 2011. <<http://www.invertershop.com.au/frequently-asked-power-inverter-questions.html>>.

“TLGwindpower” TLG-500 wind turbine.

[Online] Available: <http://www.tlgwindpower.com/>

All About Circuits, “Rectifier Circuits”

[Online] Available: [http://www.allaboutcircuits.com/vol\\_3/chpt\\_3/4.html](http://www.allaboutcircuits.com/vol_3/chpt_3/4.html)

Home Power, “Wind Electricity Basics”

[Online] Available: <http://www.homepower.com/basics/wind/>

Northern Arizona Wind and Sun, “What is a Charge Controller”

[Online] Available:

<http://www.windsun.com/ChargeControls/ChargeCont.htm>

Dynetic Systems, “Brushless vs Brushed”

[Online] Available:

<http://www.dynetic.com/brushless%20vs%20brushed.htm>

Energy Bible, “Wind Turbines”

[Online] Available: [http://www.energybible.com/wind\\_energy/wind\\_turbines.html](http://www.energybible.com/wind_energy/wind_turbines.html)

International Rectifier, “Product Information Power Integrated Circuits”

[Online] Available: <http://www.irf.com/product-info/cic/>

[www.mdpub.com](http://www.mdpub.com)

<http://www.freesunpower.com/chargecontrollers.php>

<http://www.mdpub.com/555Controller/>

<http://diyaudioprojects.com/Technical/Voltage-Regulator/>

<http://batteryuniversity.com>

[http://www.windsun.com/Batteries/Battery\\_FAQ.htm#Battery%20Voltages](http://www.windsun.com/Batteries/Battery_FAQ.htm#Battery%20Voltages)

<http://www.winglette.com/batterybank.htm>

<http://www.batterystuff.com/kb/articles/battery-articles/battery-basics.html#6>

<http://www.bdbatteries.com/peukert.php>

<http://www.sonnenschein.org/Gassing.htm>

[www.energy1batteries.com/](http://www.energy1batteries.com/)

[www.progressivedyn.com](http://www.progressivedyn.com)

<http://www.mpoweruk.com/performance.htm>

<http://www.freewebs.com/acselectronics/buildppt.html>

nerdgirls.org

K. Kalaitzakis, E Koutroulis, “Design of a Maximum Power Tracking System for Wind-Energy-Conversion Applications”, IEEE Transactions on Industrial Electronics, Vol. 53

## 9.2 Image Permission

### Figure 3:

From: dwaynesmith@hotmail.com  
To: terry@tlgwindpower.com  
Subject: TLG-500  
Date: Sun, 22 Apr 2012 14:31:28 +0000

To whom it may concern:

My name is Dwayne Smith and I am representing a group of students from the University of Central Florida currently taking Senior Design. We are currently exploring the use of your TLG-500 unit. Our sponsor Shaun Dunbar has initiate contact with you already. We would like to request the use of image as well as information relating to the TLG-500 unit for design purposes and reproduction in our design paper. This project is for educational use only and no commercial interests will be pursued.

If permission for use is granted, please email me back at dwaynesmith@hotmail.com

Thank you for your time.

Respectfully,  
Dwayne Smith  
University of Central Florida College of Electrical Engineering  
Group 9- Intellaturbine  
Email: dwaynesmith@hotmail.com

### Figure 2:

From: dwaynesmith@hotmail.com  
To: sales@greenpower4less.com  
Subject: WindMax-HY-1000-24  
Date: Sun, 22 Apr 2012 15:03:20 +0000

To whom it may concern:

My name is Dwayne Smith and I am representing a group of students from the University of Central Florida currently taking Senior Design. We are currently exploring the use of your WindMax-HY-1000-24 unit. We would like to request the use of image as well as information relating to the WindMax-HY-1000-24 unit for design purposes and reproduction in our design paper. This project is for educational use only and no commercial interests will be pursued.

If permission for use is granted, please email me back at dwaynesmith@hotmail.com

Thank you for your time.

Respectfully,  
Dwayne Smith  
University of Central Florida College of Electrical Engineering  
Group 9- Intellaturbine  
Email: dwaynesmith@hotmail.com

**Figure 47:**

From: dwaynesmith@hotmail.com  
To: information@windsolarenergy.com  
Subject: Wind Resource Map  
Date: Sun, 22 Apr 2012 18:54:37 +0000

To whom it may concern:

My name is Dwayne Smith and I am representing a group of students from the University of Central Florida currently taking Senior Design. I would like to use images from your website for a research document on alternative energy systems. I'm emailing you for permission, since it is posted on your website.

If permission for use is granted, please email me back at dwaynesmith@hotmail.com

Thank you for your time.

Respectfully,  
Dwayne Smith  
University of Central Florida College of Electrical Engineering  
Group 9- Intellaturbine  
Email: dwaynesmith@hotmail.com

**Figure 9 & Figure 10:**

From: **Joaquim Thompson** (joaquim@knights.ucf.edu)  
Sent: Sat 4/21/12 4:56 AM  
To: batteryu@cadex.com  
Dear Isidor Buchmann,

I am an electrical engineering student at the University of Central Florida and I would like to ask permission to reuse two of your figures as battery research in my wind turbine senior design project. I have read the permission to publish section of your website and will mention your name and Cadex Electronics. At the end of the summer the research paper will be put online as part of the 2012 UCF senior design class projects. The links to the figures are below. Thank you for your time, I look forward to your response.

**Table 1: Characteristics of commonly used rechargeable batteries**

[http://batteryuniversity.com/learn/article/secondary\\_batteries](http://batteryuniversity.com/learn/article/secondary_batteries)

**Figure 4-4: Charge stages of a lead acid battery**

[http://batteryuniversity.com/learn/article/charging\\_the\\_lead\\_acid\\_battery](http://batteryuniversity.com/learn/article/charging_the_lead_acid_battery)

Sincerely,  
Joaquim Thompson