



University of Central Florida

Automated Coil Gun
Senior Design I Report
Group 1

Group Members

Austin Akey
Joshua Sanchez
Donald Freeman
Brett Oden

Spring 2014

Table of Contents

1.0 Executive Summary

1

1

2.0 Project Description	3
2.1 Motivation for the Project	3
2.2 Project Goals and Objectives	4
2.3 Project Specifications and Requirements	5
2.3.1 Coil Components Specifications	5
2.3.2 Control System Specifications	5
2.3.3 Software Specifications	7
2.3.4 Power Specifications	8
3.0 Background/Research	10
3.1 Similar Projects	10
3.1.1 Coil Gun Projects	10
3.1.2 Automated Turret Projects	14
3.1.3 Accelerometer Control Apps	16
3.2 Related Technology	18
3.2.1 FPGA/Microcontroller	18
3.2.2 Wireless Communications	19
3.2.3 Motors	20
3.2.3.1 Servo Motors	21
3.2.3.2 Stepper Motors	22
3.2.4 Optics	23
3.2.5 Design Software	25
3.3 Projectile	26
3.4 Barrel	27
3.5 Magnetic Field	28
3.5.1 External Iron	29
3.6 Heat Dissipation	30
3.7 Automatic Reload	31
3.8 Velocity Detection	32
3.8.1 Experimental Methods	32
3.8.2 Real Time Methods	34
3.9 Capacitor Type	35
3.10 Power Sources	37
3.10.1 Batteries	37
3.11 Power Conversion	38
3.11.1 AC/DC Conversion	38
3.11.1.1 AC Step-up	41
3.11.1.2 DC Step-up	42
3.11.1.3 DC Step-down	43
4.0 Design	45
4.1 Projectile	45

4.1.1 Magnetic Properties	45
4.1.2 Projectile Fabrication	46
4.2 Barrel	47
4.3 Force and Energy Characteristics	48
4.4 Coil	51
4.4.1 Dimensions	52
4.4.1.1 Diameters	52
4.4.1.2 Length	53
4.4.2 Conductor	54
4.4.2.1 Conductor Type	54
4.4.2.2 Insulation Type	54
4.4.2.3 Conductor Sizes	55
4.4.3 Coil Simulations	57
4.4.3.1 Inductor Simulator	57
4.4.3.2 RLC Simulator	58
4.4.4 Heat Dissipation	60
4.5 Magnetic Field	61
4.6 Automatic Reload	63
4.7 Velocity Detection	63
4.8 Automated Turret	64
4.8.1 Power and Control	65
4.8.2 Mounting Hardware	67
4.8.3 Position Feedback	68
4.9 PCB Components	69
4.9.1 Wireless and USB	70
4.9.2 GPIO Pins	71
4.9.2.1 Input	71
4.9.2.2 Output	72
4.9.3 Microcontroller	73
4.9.3.1 Hardware	73
4.9.3.2 Software	74
4.9.4 Power	75
4.10 Optics	76
4.11 Software Implementation	77
4.11.1 Software Block Diagram	77
4.11.2 Android vs. IOS	78
4.11.3 User Interface	79
4.11.4 Wi-Fi P2P Communication	81
4.11.4.1 Camera Feed	82
4.11.4.2 Password protected launch	84

4.12 Capacitor Charge and Discharge	85
4.12.1 Mode 1	87
4.12.2 Mode 2	88
4.12.3 Mode 3	89
4.13 Power Supply	90
4.13.1 Energy Source	91
4.13.1.1 Batteries	91
4.13.1.2 Wall Outlet	91
4.13.2 Turret Power	92
4.13.3 Control Power	92
4.13.4 Coil Power	93
4.13.5 Circuit Protection	93
4.13.6 User Safety	94
5.0 Design Summary	96
5.1 Final Gun Design	96
5.2 Final PCB Microcontroller Design	97
5.2.1 Schematic and PCB Layout	97
5.2.2 Microcontroller Software	99
5.3 Final Turret Design	100
6.0 Prototype Construction	102
6.1 Gun Components	102
6.2 Microcontroller Prototype	104
6.2.1 Breadboard Microcontroller	104
6.2.2 PCB Microcontroller	105
6.3 Supply Power	106
6.3.1 Equipment Housing	106
6.3.2 Wiring Harnesses	107
7.0 Prototype Testing	109
7.1 Bench Testing	109
7.1.1 Charging Circuit	109
7.1.2 Gun Components	110
7.1.2.1 Coil and Projectile	110
7.1.2.2 Firing Position	111
7.1.2.3 Velocity Detection	112
7.1.3 Turret Control	112
7.1.4 Firing Modes	113
7.1.5 Control App	114
7.1.6 Capacitors	115
7.2 Field Testing	116
7.3 Efficiency	117

8.0 Administration Content	119
8.1 Project Milestones	119
8.2 Project Budget	121
Appendix A – References	124
Appendix B – Permission Requests	127
Appendix C – Matlab Codes	131

1.0 Executive Summary

1.0 Executive Summary

The Automated Coil Gun is an accelerometer controlled coil gun that is controlled by an android device. This project will have many features including a multi firing mode coil gun, a wireless camera, a voltage sensor, and motion on a limited plane. One of the reasons this project was chosen was all the different areas of engineering this project would require. Having group members in electrical and computer engineering gave the group a varied background and the ability to truly implement features that others might be limited to. This project required knowledge in electromotive forces, power systems, embedded systems, computer architecture and software development. Not only did this project challenge the group but it also provided a foundation for future jobs with the knowledge gained. The most important part in the group's decision to do this

project was the interest in the subject. This subject delves into many interesting and fun topics with an overall outcome that can be seen.

The main objective of this project was to design a way to fire a projectile in a more innovative way than using gun powder. Innovation was important and came in the form of remote controlled implementation using accelerometers and a wireless camera to allow a more practical and hands on feeling. The benefit of doing it without gun powder is the functionality that can be added. With a standard gun, the heat and power generated puts certain limitations, such as selection of distance. Once a gun is fired, the bullet has a set force that will in turn give it a set distance, but using a magnetic force gives the ability to adjust the force to the user's preference. As the future of technology is becoming more powerful and prevalent it was important to use it to the group's disposal. Using electricity to power most of the coil gun allowed for other features to be implemented that might otherwise require extra hunky things to be added. Things such as a camera, optical sensors or Wi-Fi module would require an extra battery that would otherwise not be needed, but with the gun being mostly powered by this technology allows for these devices to be attached at no extra expense to the gun itself.

This project will function using an Android application running off of a cell phone. The application will communicate with the coil gun through a Wi-Fi module built into a printed circuit board. In order to control the coil gun, servo motors will be attached to a hand built mount that with input from the user will move in the corresponding direction. These motions will be dictated by signals read from the built in accelerometers located inside the cell phone. Once these signals are generated a corresponding output will be generated in order to properly manipulate each individual part. A signal communicating the voltage from the coil to the control application was also generated in order for the controller to help narrow down potential problems. The application received a live video feed from the end of the barrel allowing a view of what was to be fired upon. These features allowed for the gun to be completely wireless to the controls itself.

In order to design, create, and test this project a substantial amount of money was needed and so our project was funded partially by Boeing. This funding allowed the project to have fewer limitations which helped make for an overall better product. All the features implemented above made for a well-rounded, difficult, and rewarding project. In the end we were able to display a piece of work that showed off all the knowledge we gained through research and studies at the University of Central Florida.

2.0 Project Description

2.1 Motivation for the Project

The motivation for this project came from the group's interest in the concepts involved and the real-world applications that the Automated Coil Gun may have. Some of these concepts that interested the group and were applied in this project are magnetic fields, power systems, PCBs, wireless communication, and Android development. Though the members of the group had never truly implemented any of these different types of concepts, once integrated in one project it seemed to be a very useful learning experience. All of these different concepts delve into some of the more elaborate aspects of engineering, which would require research and testing to truly grasp and implement. This complexity is what made the project that much more fascinating, as it would take a group effort to complete everything.

Real-world applications of this project include, but are not limited to, the military and oversight of the handicapped. Of these, the military application is the most practical. The coil gun could help cut back, or even eliminate, one of the military's biggest issues: that of human casualty. The benefit of the Automated Coil gun is the freedom to control the gun wirelessly, freeing the controller from putting himself in harm's way. Another benefit this coil gun could provide in military use is the ability of 24 hour patrol. This would allow for recording and review of altercations by simply adding a server for video storage. The benefits of this application could greatly improve military functions at relatively low cost.

Although the next real-world application doesn't fully use all the functions of this project, it uses some of the features executed in the subsections. As oversight of the handicapped is an all-day task in many people's personal lives, applications

are being developed every day to help provide the most up to date way of doing this. People who care for and supervise the handicapped know how overwhelming this task can be. The wireless video feed that is directly uploaded to an Android device remotely, and the ability to control the view of the camera, are features implemented by the Automated Coil gun that can also be used in helping a caregiver's supervision. One of the biggest challenges of being a caregiver is the lack of freedom in terms of the inability to leave the handicapped person's side. However, with this video feed being able to be uploaded directly to a mobile device, it provides the benefit of surveillance from any location. This benefit can even be applied to supervision of the elderly, security, and baby monitoring with just a few adjustments.

The most important motivation for choosing this project was the group's interest in the various concepts involved. The group's interest in the concepts of this project is very significant, as without it, the creation of the Automated Coil gun would seem more of a chore than an interesting, willing learning experience. This would negatively impact the overall outcome of the project making for a less than desirable final project. The goal of this project was to teach the group something new and to create something everyone would be proud of. If this was not the case, the project would turn out to be waste.

The positive motivation for this project made for an overall better experience. Both of the real-world applications discussed are directly relevant to the group members, as some were planning on joining the military and others have dealt with handicapped family members. The real-world applications and interesting concepts of the project motivated the entire group into making a fully functional product that they could be proud of.

2.2 Project Goals and Objectives

In order to get an overall quality product out of our project certain goals and objectives were set. These objectives were important to be met in order to get a more functional coil gun. The objectives include high fire rate, high power, adjustable firing modes, precision, motion using an accelerometer, wireless capability, and portability. The objectives included in this helped define the core for the rest of the project. The different goals are discussed below.

High Power – The power generated by the coil needed to be large enough to fire the projectile with a velocity of up to 120 feet per second. This velocity was determined to be powerful enough to give the projectile some strength to go at least 50 feet while not being overly powerful to shoot through certain materials. The voltage required to generate this velocity was close to 350 volts.

Adjustable Firing Modes – In order to add functionality and to take advantage of the different capacitors the group wanted to implement three different firing

modes. The ability to switch between automatic, semi-automatic, and burst firing mode made the automated coil gun different from a lot of other similar projects.

Precision – Reliability in terms of precisions was important to implement. With a gun able to move and fire at such a high rate accuracy was important. The precision to be achieved was set at a boundary of within 5 inches in any given direction. Although this accuracy did not seem to be very precise with many different factors to consider this would be accurate enough in terms of safety.

Motion Using an Accelerometer – Motion was important to the project to make the coil gun have the automated feature. With the growth in the mobile market it was decided to use this in our implementation. One of the growing features in the mobile market is the use of the accelerometer to control different functions, and this ultimately motivated our group to do the same. This technology would help provide precision while giving a more hands on feel for the user.

Wireless Capability – In order to free the user from physical distance to the coil gun itself, it was decided to make the control app fully wireless from the gun itself. This wireless capability allowed a bonus feature of safety as it allowed the controller to be at a safe distance away from the gun itself in case of any mishaps.

Portability – With the requirements of testing and the limitation of only building one final project, portability was important. With a live gun such as this testing locations were limited and needed to be done quite frequently. In order to adjust for this being able to move the device with relative ease was important. This portability also allowed for a much neater and easier to fix project as parts were in a well ordered manner.

2.3 Project Specifications and Requirements

2.3.1 Coil Components Specifications

The specifications of the coil and its components are established from the desired outputs of the coil gun. The coil needs to be of sufficient design to achieve a maximum muzzle velocity of 120 feet per second for the designed source applied and to have the ability of firing multiple rounds in succession. The coil designed must generate a magnetic field strong enough to accelerate the projectile from a stationary position to the specified muzzle velocity. The coil must also be designed in a manner such that the LC time constant allows for a current pulse that dissipates once the projectile reaches the center point of the coil. The only limitation on the coil dimensions is the inner diameter, which is established by the projectile and resulting barrel design. The coil will be fabricated to allow for easy and repeatable production of coils that can be removed or added to a barrel with effectively zero air gap between the coil and barrel. The coil must be fabricated in a clean and professional manner with

standards meeting industry production standards.

The projectile needs to be made of a ferrous material with sufficient magnetic permeability to generate adequate magnetization to accelerate the projectile. The projectile needs to be fabricated in a manner to limit friction as it accelerates along the barrel and exhibit stabilized flight. The projectile should be longer than round to achieve the necessary magnetization. To limit the energy source required to accelerate the projectile the projectile's mass needs to be less than 12 grams. The barrel must be made of a nonferrous material so that the magnetic field can pass through to the projectile. A method of loading the projectile must be designed that allows for the automatic firing of multiple rounds. A method of accurate velocity measurement needs to be designed, integrated into and displayed by the control app. The finalized coil gun also needs to be constructed as a production model.

2.3.2 Control System Specifications

Interacting with every part of the automated coil gun project is the system control board. It will be in constant communication with the operator's mobile device, the turret system, coil gun, power system, and video stream. The control system has many specific requirements as it is such an integral part of the automated coil gun project.

One of the main functions of the system control board is its ability to contain the proper interface to communicate with all other subsystems in the project. The communication interfaces needed by the system control board can be seen in Figure 2-1. Each subsystem requires a unique component to relay data to and from the control board. A universal serial bus (USB) port is needed as the interface for data input from the camera stream. The use of a USB interface for the camera will accommodate for the widespread use and availability of USB cameras. The USB port will also have the capability of being used to establish a connection when programming the processor. A wireless module is required for relaying the incoming video stream from the control board to the mobile device of the operator. The wireless module will receive signals from the mobile device for the operator to control movement of the turret system and to control the firing of projectiles from the coil gun. It will also transmit the status of the system to the operator's mobile device for monitoring. The control board will have general purpose input/output (GPIO) pins. Input pins are required to receive status signals from the projectile sensor, the capacitor sensor, and receive feedback for the turret position. Output pins are required for the operation of the two motors that control the pan and tilt movements of the turret. The output pins will also be used for the signals to fire a projectile and operate the status light. The last interface required is for power input, to operate the control board and its components, and power output to operate the servo motors and sensors.

The processing unit on the control board is required to handle multiple tasks

simultaneously for smooth operation of the system as a whole. It will need to monitor the sensors for the capacitors and projectiles in order to place the proper limits on when the operator will be able to fire a projectile. If the capacitors are not charged to a sufficient level then the processing unit will need to prohibit a fire command from going through. Likewise, if a projectile is not in the proper position the processing unit needs to prohibit a fire command from going through. The processor is also required to control the status light which indicates when the system as a whole is ready to fire a projectile. It will also be required to ensure that the video feed is relayed from the camera to the operator's mobile device. Lastly, the processor is required to relay each of the command signals to the appropriate subsystem at the correct time. This relay will include the signal to control the movement of the turret within the restrictions of its range of motion. Also included is the transmission of the signal to fire a projectile when each subsystem is ready to fire.

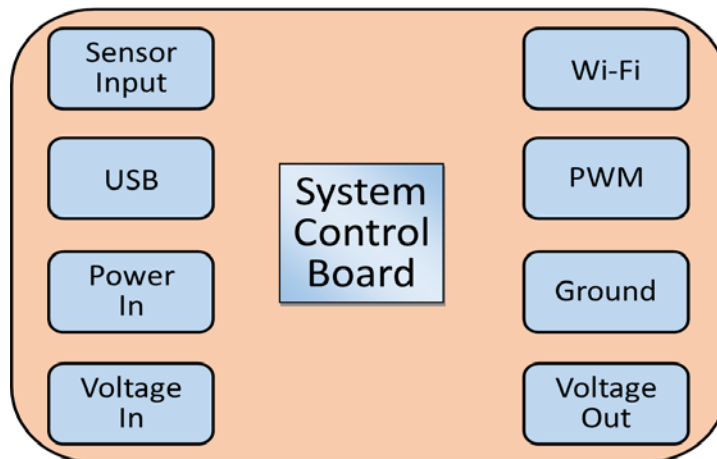

Figure 2-1 – System Control Board Interfaces

2.3.3 Software Specifications

The software aspect of the project would have many requirements in order for the device to be operational. Since all of the User Interface would be located on the Android device, this is where the core of the software would also be located. The software took care of creating an ad hoc network, locating and displaying video feed, using the accelerometers signals properly, and generating signals the PCB could understand. Although the majority of these requirements were interpreted and ultimately controlled by the PCB, the control app made it possible for the user to communicate to the coil gun.

The first requirement that needed to be implemented was the creation of this ad hoc network as the gateway between the controller and the coil gun. The important features that needed to be implemented in this network were security, communication over distances, stability, and error recovery. If any of these features were not applied properly, the adverse effects could be improper functioning or complete failure of different parts.

Next, the location and displaying of the video feed was another priority, as it was the main view the user would see and would provide feedback as to what the user was aiming at. This requirement would increase the safety of the coil gun, as it would eliminate “blind firing”. The software would also need to take care of formatting this video feed; otherwise it would not be displayed.

In order for the coil gun to be rotated and moved, the software must read the Android's built in accelerometers. This movement would occur in the 3D plane, so three different sensors were used to track this. The accelerometer, gravity, and the gyroscope sensor were all directly related to the motion detection of the user, in terms of shake, tilt, spin and turn so they provided the best feedback. These sensors provided raw analog signals, and it was the software's job to convert these into usable digital signals. This took care of motions in all three planes.

Generating the signals that got passed onto the PCB was the most important part of the software, as it dictated everything that the coil gun did. These signals needed to be concise and accurate to what the user actually wanted out of the device. This dictation was the heart of the entire application so it was tested the most extensively. If any miscommunication occurred, a false signal could be generated, such as “fire” instead of “turn left”. There were so few signals that were generated that mapping a false signal at this extreme was very unlikely but very important to avoid.

The overall specifications of the application is to be able to work on many different devices, to properly format the user interface to different screen sizes and to limit the resource consumption on the users device. As there are over 15 different android software versions, screen sizes ranging from 2.8 inches to well over 10 inches, and many older devices with limited ram, many issues needed to be adjusted for. One of the best ways of fixing this problem was to limit specific software versions from using the application as each version has a lower bound limit on its specifications. After this was done, the process of allowing the device to dynamically adjust for the rest of the devices was easily done using many built in functions of the AndroidOS. Once all of these factors were taken care of, the specifications were complete.

2.3.4 Power Specifications

The design of power in any project is usually one of the last considerations. Many projects have goals of minimizing the power consumption in order to reduce heat dissipation and operating costs. Clever ways of dissipating heat, such as using a heat sink or light bulb, need to be taken into consideration to ensure parts do not overheat and burn up. Reducing power consumption is desired to minimize operating costs. Power has cost, and long term operating costs need to be taken into consideration when considering design. Often-times performance and power

are proportional. High performance requirements usually lead to higher power requirements and vice versa. In design, it is common to meet the desired performance specifications and then try to minimize the power consumption. The design specifications of any project are the first considerations since requirements need to be met such as desired temperature, speed, brightness, etc. The minimal power required to obtain these specifications are then considered and integrated into good designs.

There are multiple options to use for the power source for this project. The most common considerable sources include batteries, solar, and power from a wall outlet. The use of batteries can be considered and has been used in previous projects, therefore this source of power is known to be achievable to meet the design specifications. Solar power has also been used in one researched coil gun design, however the power requirement for the coil is high and solar power normally requires large surface areas in order to provide sufficient power, which would lead to a bulky design. The use of a boost converter may solve low voltage from the solar panels, however this will still result in low power and may lead to very slow charge times. The use of solar also depends on weather conditions and direct sunlight. The researched project was not able to achieve enough power from the solar panel and in the end had to use power from a wall outlet. Therefore, the use of power from a solar panel will not be considered. Power from a wall outlet will be the primary consideration since this power is steady and readily available. Also, the use of 120 volts will be an advantage since the coil will require high currents in order to produce a significant magnetic field to launch the projectile. Therefore, the voltage will not have to be increased as much as if a smaller voltage from another power source was used. The downside to using power from a wall outlet is requiring close proximity to the outlet. The use of an extension cord or generator will allow the proximity to increase, however extension cord length restrictions will keep this within a limited range. The use of a generator will be possible but not considered since generators can be expensive and will be an unnecessary and irrelevant consideration in the design.

The power source for this project is a 120 volt, 60 Hertz signal. While this power will work for most household appliances, this will not charge the capacitor bank to its full capacity. Mentioned in the capacitor type Section 3.9, this project will be using capacitors that have a maximum voltage range of 450 volts. This means the input power is not sufficient to charge the bank to significant voltage levels; a higher voltage is needed. This can be accomplished using a transformer.

From the use of the 120 volt, 60 Hz power source, desirable current can be passed through the coil to provide the magnetic field. This alternating current will need to be stepped up through a transformer, which will be done through alternating current. The alternating current could also be rectified first and then stepped up through a boost regulator. The advantages of both of these are discussed in Sections 3.11.1.1 and 3.11.1.2.

3.0 Background/Research

3.1 Similar Projects

3.1.1 Coil Gun Projects

There are multiple coil gun projects that have been made by hobbyists, engineers, and researchers. Coil guns made by hobbyists and enthusiasts, which seems to account for most of the coil guns that have been made, range from crude contraptions, to elaborate new and improved devices. Coil guns made by engineers and researchers seem to be far less common, though the fact that material related to “professional” coil guns is not as common seems to suggest that either there is not as much interest by professionals to create coil guns, which is not likely, or that these professionals work for companies and defense contractors that may plan to create coil gun devices and technologies that they wish to patent and profit from, which is highly likely.

Hobbyist Barry Hansen has created multiple coil gun designs. The so called “Mark I” to “Mark V” coil gun designs all involve the same basic coil gun principle of passing an electric current through a conductive wire to produce a magnetic field that accelerates a projectile. The Mark I coil gun design consists of a drill handle mounted to a plastic enclosure and fires a screw 16 feet straight up into the air. The Mark I design contains three coils, which requires control and timing. This is because the coils need to be switched off and on at precise times in order to prevent the coils magnetic field from pulling the projectile back into the barrel. Barry Hansen used a 555 timer and an oscillator circuit in order to create proper timing. The projectile used is a small drywall screw. The results of this design were meager. This would be considered a crude design, especially since Mr. Hansen didn’t finish it, admitting it was a complicated and inefficient model. The coil gun designed here will not contain multiple stages and will be less complicated than this design.

The Mark V model is the latest design (as of 2009) created by Barry Hansen. This design of course uses the same basic concepts, however this time the coil gun is single stage, which is much less complicated since a single stage coil gun does not require timing circuits to turn the multiple stages on and off with the use

of multiple switches. In addition, this design uses an impressive capacitor bank with 22, 2200 microfarad capacitors with max voltage ratings of 480 volts, which results in around 6000 Joules of energy. This is a large amount of energy that can be stored. According to Mr. Hansen, the intention was for this coil gun design to launch a fairly large projectile at high speeds. The key feature of this coil gun design, besides the massive capacitor bank, is the wedge contactor concept design for the switching circuit. The concept of the wedge design is shown in Figure 3-1. A common problem with dumping a large amount of energy into the coil is slow closure time and the switch itself, which tends to arc and spark of the contacts as the gap starts closing, which can waste energy that is intended for the coil. The wedge design concept has an angle of eight degrees because this allows the wedge to stay in place and complete the circuit without any mechanical mechanism to hold it. The idea of a larger capacitor bank will be used for this project. The use of a mechanical switching circuit will not be used. Instead semiconductor devices will be used for the switching and charging circuits. The completed design of the Mark V coil gun by Barry Hansen is shown in Figure 3-2. [1]

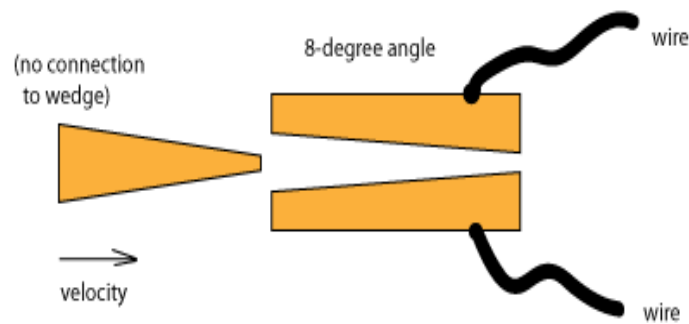

Figure 3-1 – Wedge Switching Concept Design (Reprinted with permission from Barry Hansen)



Figure 3-2 – Mark V Coil Gun

(Reprinted with permission from Barry Hansen)

Another coil gun design, which was created in summer 2010 by Brian Hoehn, Kwok Ng, Ricardo Reid, and Josef Von Niederhausern from the University of Central Florida, used an automated turret design concept. This coil gun features an automated optical targeting system. This project uses an FPGA (Field Programmable Gate Array) and a camera to store and calculate the movement of objects by the finding the centroid. This device uses a capacitor bank that is charged and discharged in order to provide the magnetic field for the coil, which is the most common design. It charges a capacitor bank through a common AC wall outlet while also trying to implement a solar panel as an alternate power source. The coil gun design involved more systems than a “common” coil gun since it includes servo motors that allow movement for tracking. Most common coil guns are made simply for trying to launch a projectile as far and as fast as possible, though some clever ways for charging and discharging capacitor banks and ways of establishing an effective magnetic field are often attempted. Still, coil gun designs are often crude and inefficient in terms of energy conversion efficiency. This coil gun project will not use image tracking (or automated targeting), though this feature has been a popular goal and achievement for students who design coil guns. [2]

A coil gun design by Jon Dagdagan, Yohan Ko, and Shashvat Nanavati from the University of Illinois included many of the basic ideas behind most coil gun projects including a capacitor bank, three coils, and a timing circuit to make sure these components operate correctly. This coil gun design uses the Arduino microcontroller in order to automate the stages of the coils. The design includes sensors to measure the distance of the projectile to coordinate how the coils will turn on and off with the right timing. The use of the Arduino microcontroller allowed these students to calculate the speed of the projectile and accurately time the discharging circuit because of the high baud rate of the Arduino board. The Arduino board has been a popular board for many students and hobbyists because of its high flexibility and speed. The use of the Arduino board, or at least a board that mimics the capability of the Arduino board, will be desired for this coil gun project. These capabilities will allow the coil gun to incorporate camera and Wi-Fi subsystems as well as speed sensors and calculations for measuring performance. [3]

Another coil gun project that will be mentioned is the electromagnetic pistol: CS-P01A which was created by James Paul at Coil Gun Systems, shown in Figure 3-3 above. This design, which is meant to be compact, includes using a boost converter to step up a low voltage power supply (a battery in this case) to a higher voltage in order to charge the capacitors. The boost converter was chosen in order to keep the design compact. Transformers tend to be bulky, and there needs to be alternating current in order for the voltage to be stepped up or down and then rectified. Therefore, the design for the pistol, which must be held, has to be compact and using batteries with boost converters is ideal. The batteries used, which were 15 cell, provided an initial 32 volts that was stepped up to

charge a 22,000 microfarad capacitor and two 4700 microfarad capacitors. [4]

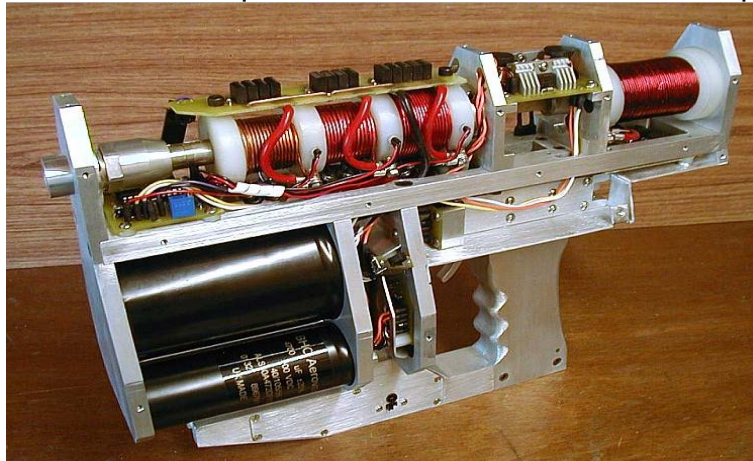

Figure 3-3 – CS-PO1A Coil Gun Design
(Awaiting permission from James Paul to reprint image.)

One last coil gun project that will be mentioned is the CG-42 Gauss Machine Gun created by Jason Murray at Delta-V Engineering. This is a portable coil gun (using Gaussian principles hence the name) that does not contain capacitors or a charging circuit. This is an advantage since the charge time of the capacitors don't need to be considered. In addition, the construction of a charging circuit is not needed. The power source for this gun is two 22 volt, 3600 mAh, 50C Lithium Polymer battery packs. The 50C means that the current burst will be 50 times the rated current, which is ideal for using in a coil gun since a current spike is what is needed to provide the magnetic field for the coil. The advantage of having a battery as the power source is that the current for the coil can be provided almost instantaneously. This allows for a multistage coil gun to be designed more easily and can allow a rapid fire coil gun design to be simplified. The use of batteries also allows this design to be portable, however the batteries need to be recharged periodically. Also, the use of SCRs (silicon controlled rectifier) for the switching circuit weren't used since the current is required to drop to close to zero to switch off. IGBTs (insulated gate bipolar transistors) were used instead. The projectiles used were steel nails. The design of the coils and barrel were typical of many other coil gun projects. [5]

Many of these coil gun designs are similar in design and construction. They of course all involve a power source, barrel, switching circuit, charging circuit, and controls. Most designs involve the use of a capacitor bank which has the advantage of providing large amounts of power, however there is the disadvantage of requiring a charging circuit and the longer charging time. The use of batteries eliminates the need of a charging circuit and allows for a simpler design of a multistage coil, however they need to be charged periodically and don't provide as much power. The design of coils and barrels are more or less the same. The firing control can vary from each design, however most are fired with a simple trigger or switch. A more advanced design for the controls and firing mechanism will be used for this project. Designs and strategies used from

these previous coil gun projects will be considered when creating this coil gun.

3.1.2 Automated Turret Projects

One of the major topics of interest in terms of research for the project included previous automated turret projects. This would help get grounding for the rest of the project as it would give a better understanding of the difficulty, time consumption, and current technologies made possible. Some of these projects were made by former students and others by hobbyists and professionals alike. These projects help to give insight into the many different styles and technologies used in some of the more modern turrets designed. The important part of this research is to take some of the better ideas and implement and expand on them in order to make a more functional product. All of the automated turrets that were looked at had similar features which included a mount and motors to control the aim of this device. The key differences in all of these were implementation, which is a very important feature in our research.

The first turret that was found was done by a previous UCF senior design group in the spring of 2012 which was called the "Remote Touchscreen-Controlled Defense Turret". This turret was all controlled using an Acer Iconia touchscreen tablet. In order to focus more on the functionality of this turret, this project replaced the original idea of using a paintball gun with a laser pointer. Without a gun this group was able to implement many more user friendly features. One of the important features of this turret was the manual versus automatic mode that was available for selection. This feature simply allowed the user to choose how a target is selected; either by computer tracking or free motion given directed by input from the touchscreen tablet. One of the impressive features of this turret was the implementation of the tracking system. Although the system used a famous library known as Open source Computer Vision (OpenCV), it was able to take it to the next step of being able to track multiple targets in a viewing window. This viewing window measured within an 85 degree angle at up to 30 meters away. Not only was this targeting system able to track objects, but it was also capable of tracking moving objects at a maximum speed of 9 meters a second. [6]

The second turret that was analyzed was the Automated Targeting Proximity Turret. This turret was completely autonomous of the user, requiring no input from the user in order to track and fire at a target. A big feature of this turret was the ability to accurately determine the distance between the turret and the user, which was used to dictate whether to fire or not. The viewing distance of this camera was able to see targets from 60 feet away, and was able to accurately fire upon someone within a range of 30 feet. Another feature of this turret was being battery operated with the ability to last for up to 5 hours before a recharge was needed. An extra feature included with this turret was a previous engagement database which stored up to 100 snapshots in a remote database. This would provide use in the ability to check if this previous target was a match to the current target at hand. In order to truly use this turret to its full capability

the project mounted multiple turrets together, and set up a grid-like structure in order to show how all the turrets worked together with all previous engagements. This set up made a better sketch out of a more realistic application of this type of technology. [7]

Another turret looked at was done in the spring of 2010, and was known as the Automated Coil Gun. This gun has a 100 fps velocity 120 degree range and 60 degree elevation. Due to this being a slightly older project than the previous two, all the controls were done through a FPGA's onboard switches and buttons. This made for a very basic, but still easy to change and control design. All controls of pan and tilt, charging, and firing were operated through this design. A special feature this project implemented was the ability to measure the mussel velocity and display it back through the 7 segment display located on the board. This speed was calculated through an optical triggered speed trap mounted to the barrel. The lack of previous documentation on this type of project made this one lack high technological features but still had all the full functionality of a higher level designed coil gun. [2]

After looking at several technologies that previous UCF students used, the next step was to look at hobbyist built turrets in order to get a different perspective. The benefit of looking at these projects is the freedom of no time limit, and the amount of effort put into each one. The first one known as the Nerf Vulcan Sentry Gun was an automatic Nerf gun mounted to a plywood base. This gun, much like others, was attached to an Arduino circuit board which ran all of its functions through an attached laptop. This gun had the standard built-in tracking system, but with an added feature. An added bonus to this feature was the ability to avoid targeting specific acquired targets, by recognizing a specific symbol located on the target. A symbol as simple as a t-shirt logo made it so that the owner of the turret could avoid fire, while other targets in the range could still be attacked. [8]

In order to get more familiar with different firing modes, a more rapid fire turret would need to be looked at. The next project known as the AirSoft project 2.0 boasted a firing rate of up to 1500 rounds per minute by having 4 singly operated barrels, all attached to a wireless remote control. Although the design of this turret allowed for it to have full automatic function, it lacked non user input control. The lack of the autonomous feature made this design less desirable, but still displayed descent accuracy despite its mass firing rate. [9]

The final type of turret out there was industrial grade turrets used by the military and companies that require extremely tight security. The first one is known as the Samsung SGR-1: The Autonomous Self-Aiming Turret Robot. This turret is capable of discerning a human from their surrounding at 500 meters away. Mounted with a machine gun a CCTV and an infrared camera, this turret is able to track potential threats, day or night, in any weather conditions. At a price tag of close to two hundred thousand dollars, this is one of the higher-end technologies out there. [10]

After looking at a slightly outdated turret, it was time to look at the most up to date innovate commercial turret on the market. This turret is being implemented at the South Korean border, and is known as the Super aEgis II. The capabilities of this turret far outmatch the previous one with a range of up to 3 kilometers. Mounted to this turret is a 35 x CCD color camera which is capable of operating in low light and adverse weather conditions, as well as a dual field of view FLIR camera. This FLIR camera can pick out a man-sized target at about 2.2 kilometers away in complete darkness. This turret is all mounted on top of a gyroscopic stabilizer to insure accurate shots even in high wind. At a weight of over 300 pounds, this turret has high durability and strength. [11]

After looking at all of these turrets and their features, many of the positives and negatives can be identified from the projects in order to avoid complications while getting full functionality. Some of the more important features pulled from these projects were servo motor movement, remote controlled touchscreen control, previous engagement storage, speed calculation, and target acquisition. In order to complete all these tasks, more research will need to be done, but now the technologies that are possible are at the forefront of our project.

3.1.3 Accelerometer Control Apps

There were many different options for controlling the motion of the Automated Coil gun, but after some research, the group decided the most unique way to control this project would be an accelerometer. This technology takes advantage of the body's natural way of movement at a moderately low price tag. Accelerometers have become very popular for the use of controlling devices and applications in recent years, from the Wii video game system, to the Smartphone. These devices take advantage of the interest of human interaction, and make for a better user experience. This technology has become so popular that most, if not all, android and iPhone devices come with a built-in accelerometer. Since a Smartphone is of relative ease to get for a cheap price, in comparison with other technologies, it ultimately pushed the group to choose this technology to control our Automated Coil Gun. In order to truly understand this technology it was best to look at previous applications that use this mechanism.

The first technology to be researched was a gesture controlled robot created by students at MichiganTech, which used a standalone accelerometer attached to a wristband. The robot to be controlled was a four wheeled vehicle that had the capability to go forwards and backwards, while steering left or right, based on the hand gesture given to it. This robot was hardwired to the accelerometer which was attached to the controller's wrist. Although the accelerometers sensors are independent in their x and y values, in order to transmit this signal to the robot, nine different commands needed to be created. Instead of being able to easily transmit the x value and the y values, a specific signal had to be generated for the commands of stop, forward, backwards, spin right, spin left, forward and right, forward and left, backward and right, and finally, backward and left. [12]

The second device that was looked at was an accelerometer controlled robotic arm. This arm had full functionality in terms of movement in a 360 degree plane, with full pan and tilt. The arm itself was connected to a PCB and received commands wireless through a Bluetooth module. The accelerometer controlled application was run on an Android device, with the prebuilt in accelerometers. In order to get the full motion of the arm itself the application took advantage of the three sensors to get the x, y and z planes current values. Once these sensors were read and decoded the application then sent a single character over the connection that correlated to a specific movement. This character was decoded by the board and the correct movement was made. This application showed how accelerometers values could be used to communicate wireless. [13]

One of the more applicable designs that implemented an accelerometer was an Accelerometer Based Hand Gesture Controlled Wheelchair. This projects goal was to help make users who were wheelchair-bound retain more freedom than that of a user who had a voice controlled wheelchair. The idea of this is very similar to the previously mentioned projects, but with the added feature of real world functionality. The sensor used in this design was an MEMS 3-axis accelerometer, which was capable of measuring acceleration in any direction. Once the direction was measured, the wheelchair was moved with a dc geared motor driven by an h-bridge. Functionality in all directions was important for this device. The h-bridge was able to do this by 4 switches, so that when it was switched different ways, it could be turned on or off with a negative or positive voltage. The effects of the switches on the circuit are shown in Figure 3-4. With this basic functionality of the wheelchair itself set up, the next step was to set up the accelerometer. Due to the restrictions of a handicapped person, it needed to be placed at a location with some mobility, but remain easy to use. The location decided upon was the index finger, as most patients had some mobility left in this area of their body. This wheelchair was able to succeed at all places where previous wheelchairs failed, proving the remarkable power and usefulness an accelerometer could provide. [14]

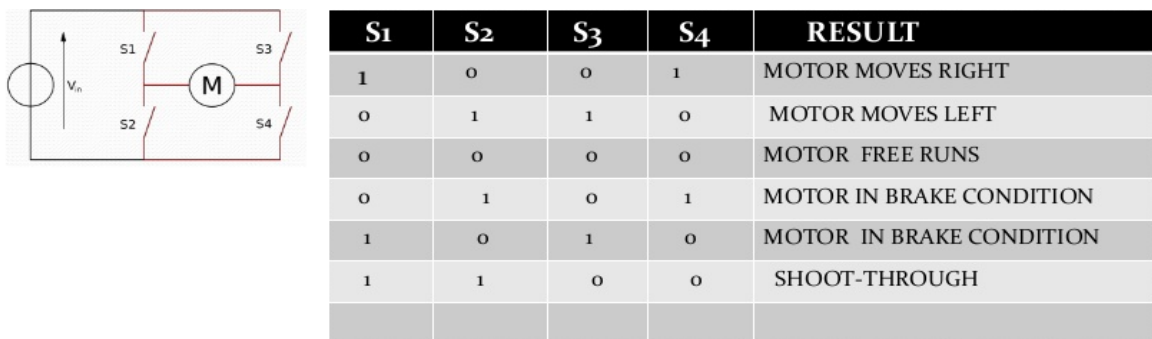

Figure 3-4 – Switch Results
(Reprinted with permission from Sukhpal Singh Saini.)

After looking at the many different accelerometers that have been implemented, many similarities could be pulled from all of them. These similarities include controlling an external device, sending of an encoded variable to distinguish the type of movement, and the accelerometer itself. These features seem to be a common requirement in order to get the true performance out of the accelerometer. The key differences between these projects are the use of wireless versus wired communication, the way the encoding was done, and where the accelerometer was located. One of the most important features of using an accelerometer in these applications and the reason the group decided to use it in the implementation of the coil gun, was its natural feel. As with most things in nature, there are no buttons. There is, instead, a type of movement that has a cause and effect relationship in order for things to be carried out. This relationship made for a much more natural controlling mechanism, which in turn made for a far more interesting project to be tackled.

3.2 Related Technology

3.2.1 FPGA/Microcontroller

The center for management of the automated coil gun is the system control board. This control unit is the communications hub for the project and interacts with every subsystem within the project. It will be ensuring that the video feed is being relayed to the operator's mobile device, taking input for the mobile device used for control of turret movement and projectile firing, and receiving input from subsystems to maintain the status of the system as a whole. A custom designed control unit will be needed to meet the specific requirements of each subsystem. The control board will require power, wireless communication, interface for video feed, power output for turret motors and sensors, as well as GPIO pins. The GPIO pins are required for control of the turret, firing of the projectile, and maintaining sensors that monitor the status of the projectile and the capacitors. Two options of system control for the project were researched, field programmable gate arrays (FPGAs) and microcontrollers.

The FPGA has some very unique features that create advantages for its application in the project. One such feature is its configurability which allows it to be more readily changed to adapt to situational revisions. This would be ideal for functions added to the project or modified at a later date. Another advantage is its unmatched ability for parallel processing that is great for tasks that can be run at the same time physically such as, transmitting the camera feed, receiving commands from the mobile device, controlling signal output of the turret, and controlling signal output of the coil gun. The parallel processing would increase throughput and decrease the time for execution of project tasks. FPGAs offer great flexibility in accommodating many varying peripheral interfaces. This would cover all of the needs for interfaces of the project control board. The FPGA also has some drawbacks that make it a less suitable fit for the project. The biggest drawback for the use of an FPGA in the project is the difficulty of the software

programming which uses a hardware description language (HDL). The collective expertise of the group is better suited for the high level languages that are often used in other control boards. The last disadvantage of the FPGA is the waste of its unused capabilities. The project does not contain enough repetitive tasks to see the full benefits of the FPGAs parallel processing capabilities. Also, the control board system only requires a small amount of peripheral interfaces that can be easily met with other control boards. For the automated coil gun project, the FPGA does not meet all of the requirement specifications as desired for the system control board.

The microcontroller is the second option for the project control board that was researched. It offers the advantage of containing a processor core and memory. These two key components are important in allowing for software programming in high level languages such as C. The ability to program in a high level language makes writing complex functions easier for the programmers who lack expertise in HDLs used on FPGAs. Due to the limited number of processes the project requires, a high level of throughput is able to be achieved using a microcontroller. When the microcontroller is designed specifically for the project it is able to achieve similar versatility offered by FPGAs in respect to peripheral interfaces. The microcontroller can be designed with multiple interfaces including; USB, power, GPIO, and wireless communications. This custom design allows for all project specifications to be met while eliminating the waste caused by unused resources. For the automated coil gun project, the microcontroller meets all of the specification requirements as desired for the system control board. [15][16]

3.2.2 Wireless Communications

A key component of the project is the wireless communication capability from the microcontroller to the mobile device. A wireless connection in conjunction with a mobile device was chosen for better flexibility and mobility of the operator. This connection is used for control of several systems within the project. The mobile device will use the wireless connection to control movement of the turret along with the firing mechanism of the coil gun. Either the microcontroller will use the connection to transmit the video feed to the mobile device or the camera itself will use its own Wi-Fi to transmit the video feed. Two options were researched for wireless data transmission between the microcontroller and mobile device, Bluetooth and Wi-Fi. Table 3-1 compares some of the major wireless communication specifications of each technology that was researched. The ranges listed for each type of technology are typical ranges that are limited by the use of mobile devices indoors.

Wireless Protocol	Frequency	Range	Data Rate
Class 2 Bluetooth 4.0	2.4 GHz	<10 meters	<24 Mbps
Wi-Fi 802.11g	2.4 GHz	<38 meters	<54 Mbps

Table 3-1 – Wireless Communication Specifications

Bluetooth is a great technology for the connection of two or more devices. The connections are easy to set up with minimal configuration. These factors make it a beneficial way to create an ad-hoc network. The transmission range provided for the class 2 Bluetooth is sufficient to operate the automated coil gun and turret from a safe distance. The drawbacks to the Bluetooth method of wireless connection lie within the bandwidth and transmission data rate. Bluetooth connectivity is best suited for applications that do not require high bandwidth and that do not need high transmission speeds. For this project, the live video feed may cause difficulties for the bandwidth limitations of the Bluetooth connection if the feed is not broadcast directly from the camera. Fast transmission times are crucial to the live video feed and real time decisions made for turret control and the firing of coil gun projectiles. Therefore, the Bluetooth means of wireless communications does not meet all requirements as desired for the project.

The application of Wi-Fi in this project creates opportunity for versatility in the method of connection between the mobile device and the system control board. With Wi-Fi an ad-hoc network can be created allowing the two devices to be connected without relying on a wireless access point. This type of connection is called Wi-Fi Direct or Wi-Fi P2P and functions similar to Bluetooth. In addition to the peer to peer setup, Wi-Fi can also be used to connect the system control board to the internet. This feature paired with a cloud like service could make it possible to access the automated coil gun from anywhere with internet access. Wi-Fi easily exceeds the required transmission range to allow safe operation of the coil gun and adds the ability for it to be used remotely from great distances. Wi-Fi also supplies sufficient bandwidth for the live video feed and control signals. Its data transmission rate allows for a real time video feed and a quick reaction time for turret control and projectile firing. For the automated coil gun project, the Wi-Fi method of wireless communication exceeds all requirements. [17]

3.2.3 Motors

The turret subsystem of the project includes the use of motors to enable movement of the coil gun for the purposes of aiming and surveillance. The motors receive signals for movement through the system control board from the operator's mobile device. Two motors will be used. The first motor will control movement in the horizontal direction. The second motor will control movement in the vertical direction. The motors must allow for fast reaction times, smooth movements, stability, and precision. Servo motors and stepper motors were researched to verify if either would meet the motor needs of the turret subsystem. Images of a pan and tilt setup of two motors, a servo motor, and a stepper motor can be all represented in Figure 3-5.



Figure 3-5 – Pan and Tilt (*left*), Servo (*center*), Stepper (*right*)
(Reprinted with permission from SparkFun Electronics)

3.2.3.1 Servo Motors

The first type of motor researched was the servo motor. A great feature of servo motors is that they are able to produce a large amount of torque relative to their small size. The high torque is essential to accommodate the weight of the coil gun and optical subsystems and allow them to be moved without straining the motor. A feature unique to servo motors is their closed-loop control. The servo make can make use of a potentiometer or some type of encoder to determine its position and use the closed-loop control to make adjustments so that the motor can be used to achieve the desired position. With closed-loop control, when the desired position is reached the servo motor rests and does not continue to draw power. Proportional control is another aspect of power efficiency in servo motors. Proportional control makes the motor turn at greater speeds when the distance between the current position and the desired position is large. Likewise, the motor turns at very slow speeds for small discrepancies in position. Closed-loop control also helps to reject disturbances from outside sources and keep the motor in the position given by the control signal. The aspects contributing to power efficiency and disturbance rejection are positive features that servo motors could provide to the turret subsystem.

Servo motors are available in many different types. One selection option that impacts the project is to decide between using an AC servo motor and a DC servo motor. They each have different scenarios in which they are most applicable. DC servo motors are more commonly used in smaller scale applications because they are generally less expensive and are simpler in design and their use. DC servo motors are usually a poor fit for large scale application such as industrial equipment because they are not designed to handle large current surges. AC servo motors are more commonly seen in these industrial applications because they are able to handle the high current surges. For the turret subsystem the servo motors will not be required to handle high current surges. Implementing AC motors for position control is more costly and less refined than implementing DC motors for position control because it requires a higher level of gear ratio reduction. Also, the AC drive used to control the AC motor is more complex than the use of pulse width modulation (PWM) in a DC

motor. Therefore, due to the lower cost and simplicity, the DC servo motor is a better fit for the turret subsystem than the AC servo motor.

One of the biggest benefits to using servo motors is the process by which the motors are controlled. The signal or control line on the servo motor is used for PWM. The pulse width is used to control the position. It will have a minimum width which will correlate to the motor turning 90 degrees from the neutral position and a maximum width which will correlate to the motor turning 90 degrees in the opposite direction from the neutral position. This function will allow the turret to have a 180 degree range of motion from the servo motor controlling the motion in the horizontal plane. The motor controlling the motion in the vertical plane would only need to use half of the maximum pulse width to allow a range of motion from the neutral position, perpendicular to the ground, to an angle of positive 45 degrees. The pulse width sent from the programmable interface controller (PIC) is compared with the feedback pulse from the potentiometer or encoder to constantly look for adjustments that need to be made in the position of the motor. Programming the PIC to use PWM is not too complex and can be done well within the scope of the project. [18]

3.2.3.2 Stepper Motors

The second type of motor researched was the stepper motor. This type of motor has three main components to its system. This simple layout makes it relatively easy to integrate into a project. The first component is the indexer which is a controller that has the ability to produce step impulses which would be the system control board for the project. The second is the driver which creates the power for the motor from the indexer's signal. The last component is the motor itself which takes the impulses and makes incremental movements or steps. Each revolution of a stepper motor is broken up into an integer number of steps. One problem that arises from using incremental steps to change angular position is its tendency for a jerky motion. The jerky motion goes directly against one of the requirements of the automated coil gun project which is to have a smooth range of motion for the turret's movement. In order to achieve a smooth movement different step modes have to be used. Stepper motors can make use of different modes such as full step, half stepping, and micro stepping. The smoothest motion comes from using micro stepping which subdivides each step from full step mode into 256 micro steps. The drawback to getting the smooth motion from micro stepping is a roughly 30% decrease in torque. This reduction in torque would have to be taken into consideration when selecting a motor for purchase.

Similar to the servo motor, the stepper motor offers good torque in relation to the size of the motor, especially at low speeds. However, the torque of stepper motors drop drastically at higher speeds. The drop in torque has the potential to cause some problems in the turret system when faster motor speeds are needed to accommodate large changes in position that need to happen quickly. Also, the stepper motor is less power efficient than the servo motor. This is due in large part to the stepper motor constantly drawing power whereas the servo motor

ceases to draw power when at rest. The constant draw of power also causes there to be a substantial amount of heat in the motor and driver components. The extra heat is able to be worked around but it is something that has to be taken into consideration when planning the physical layout of these components in relation to the materials and components surrounding them.

These types of motors are available in three main subcategories. The three subcategories are the variable reluctance stepper, the permanent magnet stepper, and the hybrid synchronous stepper motor. The hybrid synchronous stepper is the best option for the project of the three because it combines all of the best features from the variable reluctance stepper and the permanent magnet stepper. The hybrid synchronous stepper generally have 200 teeth which would have some jerkiness in its movement if the standard full step mode was used. To meet the project requirements micro stepping would need to be implemented if this type of motor is chosen for the turret system.

Stepper motors most commonly implement open-loop control due to the fact that they do not have encoders. This has the advantage of creating a less complex layout making it more economical in cost and amount of work. There are some serious disadvantages in using open-loop control the project's turret system considering that it is used to control the aiming of a projectile to be fired. The most pertinent of these is the absence of feedback which makes it impossible to detect and correct missed impulses which leads to positional errors. These type of errors create safety concerns because there is a greater potential for inaccuracy in the aiming process of the coil gun. To address this problem a feedback circuit can be added to a stepper motor by incorporating an encoder into the system, thus creating closed-loop control. This addition solves the issue of positional errors but it also adds unnecessary cost and complexity to the system when the servo motor already incorporates closed-loop control. [19][20]

3.2.4 Optics

The project will have a video subsystem implemented on the coil gun. The video feed captured will be from the viewpoint of the barrel of the coil gun. It will be used for the purposes of surveillance and aiming. The live feed will be transmitted to the operator's mobile device to allow the operator to view the video from a safe area. The most important factor of the video subsystem is to keep a steady streaming video. The video should not slow to the point that it presents still images or lags behind what is actually being viewed by the camera. These requirements are in place to provide a layer of safety. It permits the operator to always be aware of what the coil gun is pointed towards when it is actually pointed there. In addition to safety, these requirements make it possible for the coil gun to function in the way it was intended. Two types of video systems were researched in order to meet the live streaming needs of the project.

The first option researched for the video system was the USB webcam. This type

of webcam is the most common and readily available to purchase. It is budget friendly considering they can be purchased for as little as 10 dollars. This type of webcam would require the use of a USB port on the system control board. The USB is a master-slave system with the camera being the slave that requires the implementation of a master. For this situation a USB host controller would have to be implemented as the master and would be placed with the USB port on the system control board. The host controller consists of the hardware and the software necessary to interface the peripheral (USB webcam) with the controlling processor. Once the video data reaches the system control board through the USB interface it would then be transmitted to the operator's mobile device using a Wi-Fi module on the control board. This data path is represented in Figure 3-6.

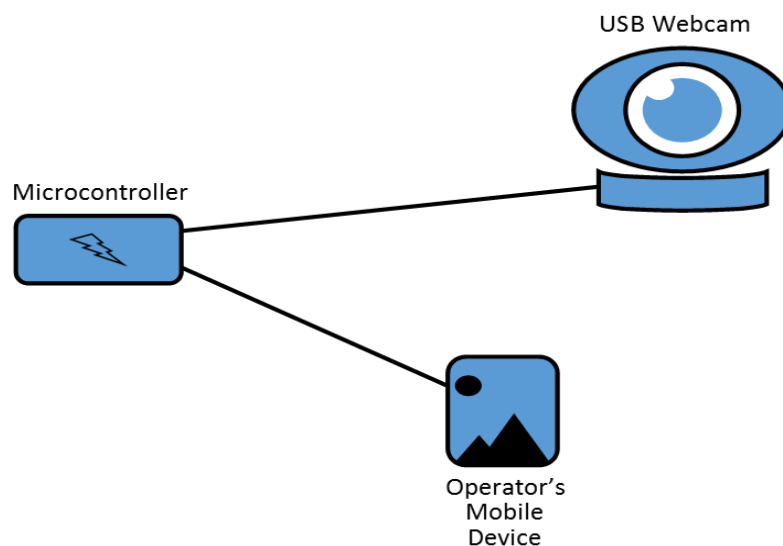

Figure 3-6 – Data Path for USB Webcam

Another option that presented itself while researching the USB webcam was the Wi-Fi webcam. This is a unique option in that it would bypass the system control board for transmission of the video feed to the operator's mobile device. The camera itself has a built in Wi-Fi module that transmits the video feed to a specific IP address. The live video stream is available for viewing through that IP address. This data path is represented in Figure 3-7. The application on the operator's mobile device would have to use this IP address to integrate the video feed into the user interface on the device. Wi-Fi webcams are however considerably more expensive than USB webcams. The use of a Wi-Fi webcam would allow for a simpler and lower costing processor to be used on the system control board because it would not have to handle the video stream which can become very resource heavy.

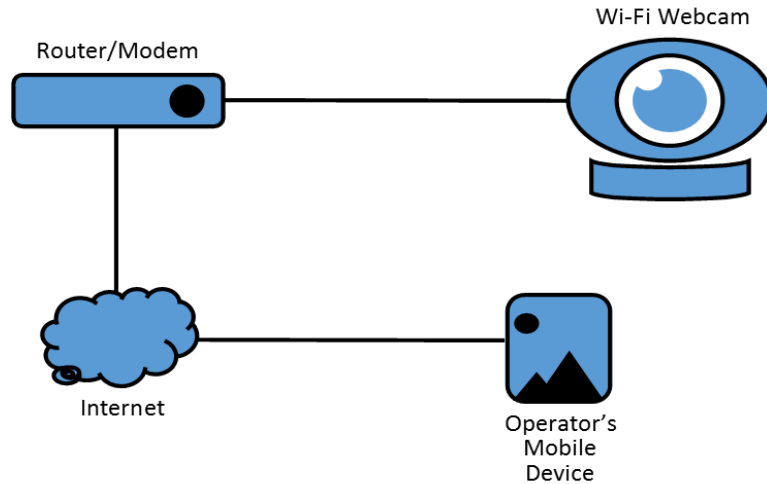

Figure 3-7 – Data Path for Wi-Fi Webcam

3.2.5 Design Software

The software used to design the printed circuit board (PCB) was another area that needed to be researched to find out what technologies were available. This research was necessary because no one from the automated coil gun project team has had any experience with PCB design software. There are several companies that provide design software and from these companies two were selected to learn more about. These two companies are ExpressPCB and Cadsoft.

The first design software researched was ExpressPCB. This software offers both a schematic design software and a PC board design software that are available for download completely free of charge. Both of these are required to complete the process of having a custom designed PCB physically produced. This software offers all of the necessary tools to design the PCB. Another aspect of research that was taken into consideration was customer reviews of the software. The general consensus found regarding ExpressPCB was that it was average to good in the reviews with some customers noting some of the negative aspects such as the software acting buggy.

The other design software researched was called Eagle, produced by the company Cadsoft. Like ExpressPCB, Eagle has both schematic design software and PC board design software. This software is available for students to use at UCF completely free and several computers already have the software installed and ready to use. ExpressPCB however is not preinstalled on UCF computers and therefore would have to be downloaded and installed on the group's personal computers. Aside from Eagle having all the features needed to complete the design of the PCB and being free to use, it also has great customer reviews. Another bonus to Eagle is that two members of the project team were able to attend the Cadsoft Eagle seminar at UCF in the spring semester of 2014. They received a great introduction to using their software and also received a

beginner's guide book with detailed steps and tutorials for using Eagle.

3.3 Projectile

When designing a coil gun the choice of projectile is just as important as the design of the coil itself. The size, material and shape of the projectile are very important in optimizing the energy transfer from the coil to the projectile. By taking into account the permeability, saturation density, friction and the aerodynamics of the projectile among other physical properties a design that maximizes the efficiency can be accomplished.

One of the major factors limiting the performance of the coil gun is the eddy currents that oppose the current induced by the magnetic flux. These eddy currents generate a magnetic field opposing the original field being generated by the coil and as a result the accelerating force on the projectile is reduced. Two approaches can be taken to reduce the eddy currents, which are adding slots along the projectile or filling an outer casing with a powdered ferrous material, somewhat similar to a shotgun shell as shown in Figure 3-8 below. The slots need to be added along the length of the projectile because primarily the eddy currents flow in a circumferential path around its surface. By adding slots along the projectile the flow of eddy currents is restricted by eliminating the solid surface for the currents to flow along. With this method care has to be taken with the placement and depth of the grooves as not to weaken the structural integrity of the projectile. The other method is to use a powdered material mixed with a resin and encased in a plastic jacket. By using a powdered matrix material eddy currents that flow in any direction will be eliminated. Another advantage to this method is the plastic jacket allows for an easily customizable shape and size. The plastic casing is also easily impacted by the rifling of the barrel if spin stabilization is desired. With this method the mixture of ferrous material to bonding resin needs to be carefully considered as the resin is not impacted by the magnetic field and may limit the efficiency of the design.

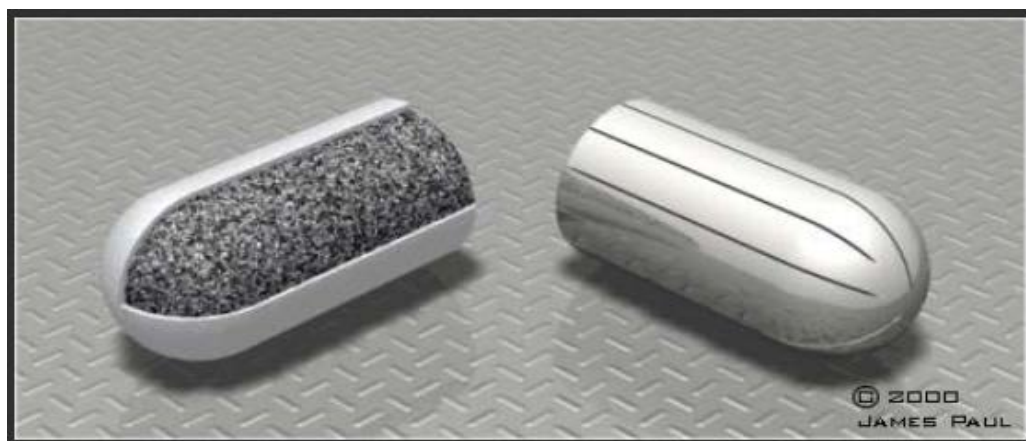

Figure 3-8 – Powder Filled Casing and Slotted Projectile
(Awaiting permission from James Paul to reprint image.)

In order to maximize the force transferred to the projectile consideration with the shape must also be taken into account. These factors affecting the acceleration of the projectile are the form drag and skin friction. To minimize these effects a balance must be found between drag and friction, simulations can be performed to streamline the projectile which will decrease the form drag. This creates a problem because the streamlined tail end of the projectile may cause it to wobble and jam while traveling down the barrel. This problem can be corrected by adding fins to the tail improving stability during acceleration in the barrel, the fins can also improve flight stabilization. The downside is added skin friction due to the fins. Using computer simulation the force curve can be optimized taking into account the form drag and skin friction.

3.4 Barrel

The barrel of the coil gun must be constructed of a non-ferrous material to allow the magnetic field to pass through to the projectile. If a ferrous material were to be used the magnetic field would be directed outward from the coil and away from the projectile. If a metal tubing were to be chosen for the design, eddy currents would greatly affect the performance of the coil gun. As with the projectile, rows of slots can be cut along circumference of the tube minimizing the eddy currents as shown in Figure 3-9. This needs to be done with precision to ensure that the projectile does not jam while traveling down the tube, as can be seen in the image if the projectile is small in relation to the slots it may try to fall out of the slots. The slots must also be carefully machined and filed to remove any burrs or defects that would increase the friction and perturb the projectile's acceleration. Another option is to use a non-conductive material such as paper, plastic or glass. While these materials don't offer the same physical strength, there is no eddy currents created by the barrel that need to be accounted for. The wall thickness of the barrel creates the required air gap between the coil and the projectile that is needed to convert the magnetic field into forward motion of the projectile.



Figure 3-9 – Slotted Barrel
(Awaiting permission from James Paul to reprint image.)

One option for increasing the velocity and stability of a projectile is to induce spin on the projectile through rifling. Rifling of the barrel is accomplished by making helical grooves along the inside of the barrel. The spin created by rifling serves to

aerodynamically stabilize the projectile and improve accuracy. The twist rate, which can range from 1 turn in 8 inches (1:8 inches) for long, small diameter projectiles to 1:48 inches for short, large diameter projectile is used to describe the barrel's rifling. By increasing the twist rate, the projectile will rotate at a higher velocity increasing its spin stability. By using equation 3-1 below, where C is 150 for a muzzle velocity less than 2,800 feet per second, D is the projectile diameter, L is the projectile length and SG is the specific gravity of the projectile, an optimized twist rate can be determined to stabilize the projectile and improve accuracy.

$$\text{Twist} = \frac{CD^2}{L} \times \sqrt{\frac{SG}{10.9}} \quad (3-1)$$

The rifling of a barrel can be achieved through various methods including cut rifling, broached rifling, button rifling, forging or flow forming. The most practical options for this project is the cut rifling, which consist of cutting one groove at a time radially along the barrel using a special machine tool. The other option is broached rifling, which is cutting all the grooves at the same time, this is also done with special machine tools. The twist ratio of the rifling must be consistent throughout the length of the barrel, as a decrease in rate of twist greatly diminishes the accuracy, where as if the twist is slightly increased along the barrel there is very little effect on accuracy and is usually done to ensure that the twist rate does not decrease. The barrel's inner diameter needs to be carefully considered to ensure that the projectile will swage, or flare out, upon firing, which is the process that initiates the projectile's spin. [4]

3.5 Magnetic Field

The function of a coil gun is to transfer a large pulse of energy to accelerate an object by passing current through a coil to generate the required magnetic field. The greatest challenge to a coil gun is optimizing efficiency, as most designs are only able to achieve a 2% energy transfer from the source to the projectile. There are two distinct methods for implementing a coil gun and they differ in the manner in which the magnetic field propels the projectile. A reluctance coil gun uses the attractive ferromagnetic properties of the projectile to generate the force required to accelerate the projectile. While the induction coil gun is used to accelerate a non-ferromagnetic projectile through the repulsive forces of the eddy-currents generated in the projectile.

For this project the reluctance coil design will be utilized. Being that the magnetic field generates the force needed to accelerate the projectile, the most common thought is to increase the size of the coil to increase the projectile's acceleration. The fact is that the density of the coil and resulting magnetic flux is one of the least important factors in developing an efficient, high powered coil, simply adding layers to a coil can often reduce the coil gun's performance. The most important part of the coil gun design is the projectile that is chosen to be fired.

This choice will determine all others that follow. A compromise needs to be found when designing the coil and current pulse to optimize the acceleration. The coil parameters need to be just right to ensure that the current pulse is timed to stop when the projectile reaches the coil's midpoint, so as to limit any counter force that would lead to projectile pull back. Another option for increasing muzzle velocity if efficiency cannot be improved anymore is to increase the number of coils. This design adds the possibility of more timing issues with the current pulse and also results in a diminishing return, as each additional coil has less effect on muzzle velocity as the duration exposed to the magnetic field in each additional coil decreases. The efficiency of the shot is also a result of any demagnetizing field that might generate in the material. This field is generated by the poles created at the ends of the projectile when it magnetizes, this creates an internal magnetic field that opposes the external magnetic field. This demagnetizing field in a projectile is related to the size of the projectile. A short projectile with a large diameter will experience a greater demagnetizing field than a long slender projectile. To optimize the net magnetic field a projectile should have a length to diameter ration between 2 and 5 to achieve the best results. The force acting on the projectile can be determined using equation 3-2, where N is the number of turns, I is the current and $d\phi/dx$ is the flux linkage, the change in flux density with respect to projectile displacement. Unlike N and I , $d\phi/dx$ is very difficult to determine but their relationship to the force can easily be seen. Increasing N and I is rather straight forward but with respect to the flux linkage, it can be enhanced by either changing the projectile to one with a higher saturation flux density or by adding external iron around the coil. As discussed previously there is always a tradeoff with the coil gun design. Making these adjustments to the system will change the inductance of the system and result in a different time constant for the coil.

$$F = \frac{1}{2} NI \frac{d\phi}{dx} \quad (3-2)$$

3.5.1 External Iron

Adding iron to the exterior of the coil can improve the magnetization of the projectile and improve efficiency of the energy transfer. The external iron has the effect of increasing the magnetic flux of the system by adding its magnetization and directing the flux lines toward the center of the coil and the projectile, as is shown in figure 3-10. The shorter flux lines cause the projectile to experience an increased force pulling on the projectile. The external iron also has the effect of reducing the reluctance of the system, which illustrated in equation 3-3 increases the magnetic flux. The reluctance is reduced by essentially eliminating the air external to the coil, which has a higher reluctance than the iron due to the inverse relationship between reluctance and relative permeability. The magnetic circuit can be modeled similarly to an electrical circuit using principles of Ohm's Law, where magnetic flux (B) replaces current, magneto motive force (mmf) replaces voltage and reluctance (R) replaces resistance.

$$B = \frac{\text{mmf}}{R}$$

(3-3)

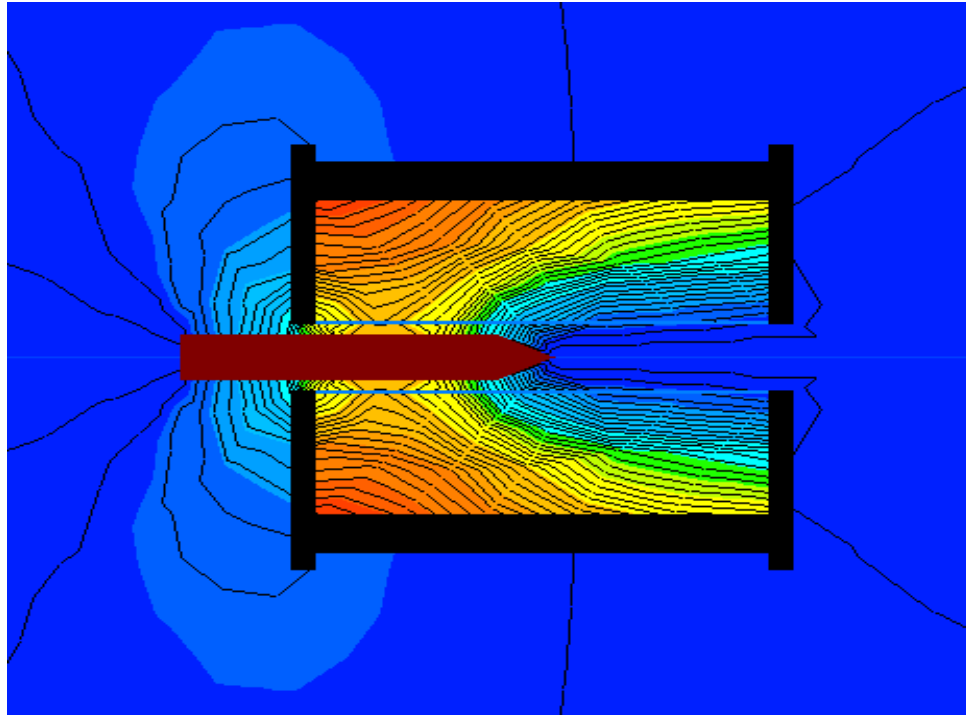

Figure 3-10 – Magnetic Flux with External Added
(Reprinted with permission from Barry Hansen.)

It is relatively easy to add external iron to a coil and can be accomplished using an iron pipe and flat washers at the ends. In order to maximize the system reluctance the external iron needs to be sized to try to eliminate any air gap between the iron and the coil. This can be a little more difficult to do if a custom coil is fabricated as readily available pipes are only found in standard sizes and may need to be fabricated as well. Another disadvantage to the added iron is the increased weight of the coil gun will make it hard to control for targeting using small inexpensive motors. The enclosed coil will also limit the ability to adequately dissipate heat that is generated by the current pulse. [1][4]

3.6 Heat Dissipation

One of the major design concerns is the coil's ability to dissipate heat rapidly enough to allow for continuous firing without damaging the coil. Since the projectile's acceleration period is only a few milliseconds it can be assumed that without the addition of a cooling system all of the heat will be dissipated in the coil's conductor and insulation. Depending on the energy dissipated in the coil, without the proper conductor sizing and cooling the coil will melt causing a short. There are various options available when trying to cool electrical components, applying forced air, submerging the coil into nonconductive oil or gas, and heat sinks.

Heat sinks are commonly used in the cooling of electronics and work on the thermodynamic principle of heat exchange. By placing a component in contact with a heat sink its surface area is effectively increased allowing for improved heat dissipation maximizing contact with the cooling medium. Although a very efficient method a heat sink may be hard to implement given the cylindrical shape of the coil. Another method commonly used in electronics is a forced air application in which a fan forces air across the component to dissipate heat. This would be a relatively easy to accomplish by placing a CPU fan in close approximation to the coil. The fan could also be integrated into the coil gun controls by turning on and starting a timer when a projectile is fired and staying on for a predetermined amount of time necessary to cool the coil or can be designed to apply a constant flow of air to the coil.

The most effective method of cooling for high energy applications is submerging the electrical component into a nonconductive oil or gas, as is commonly done with large transformers, generators and underground transmission lines. Implementing this type of cooling system would require designing some type of vessel to contain the coil and coolant, allowing for any expansion due to the natural convection process and the added weight would make it more difficult to implement the targeting aspects of this project. Although liquid cooling provides an effective option its downsides far outweigh its advantages for this project as its costs and effort to design would exceed the scope of this project.

3.7 Automatic Reload

In order to achieve the semi-automatic firing of the projectiles, the coil gun not only needs to be designed to handle the current pulse but also needs to position a new projectile in the correct location to be attracted by the magnetic field after every shot until the magazine is empty. This can be accomplished using a gravity fed system, mechanical system or electromechanical system. For all of these designs the barrel has to be modified, by cutting a slot to allow the projectile to be loaded into place. Just as with the slots that would need to be added to a metal barrel to negate eddy currents, the barrel would need to be machined in a manner that allows the loading mechanism to mechanically work and keep the projectile from jamming as it is fired.

The gravity fed and mechanical fed system for loading a projectile would operate in the same fashion. The gravity feed would be a top fed design in which a box magazine, similar to tradition fire arms, would be mounted to the barrel and allow the projectiles to simply fall into place. For this design the magazine would need to be positioned in a manner that the projectile would be adequately magnetized to induce acceleration. The projectile would also need to be held in place to keep the projectile from sliding along the barrel as the coil gun's position changes from the turret targeting system. This can be easily accomplished by installing a bolt in the end of the barrel with a weak magnet to hold the projectile in place.

The mechanical magazine would operate in a similar manner by locating the clip in a location that allows the projectile to be magnetized and accelerated. The difference of this design is that the projectile could be fed from either the top or bottom, by adding a spring in the magazine that pushes the projectiles into the barrel. Some of the concerns with this design is finding or fabricating a spring with a spring stiffness that exhibits enough force to move the projectile into place without too much force, pushing the projectile against the barrel wall negating the force pulling the projectile through the coil.

The electromechanical design could be implemented using either of the two magazine designs above. This would be accomplished using a small push-pull solenoid. The solenoid can be mounted behind the projectile or in line with the projectile by adding an arm to the solenoid to push the projectile into place. This design complicates the mechanical aspect of the loading mechanism that can increase chances of jamming or miss firing of the coil gun. For the bottom fed magazine that uses a spring to load the projectile, the force pushing the projectile into the barrel may cause the solenoid's plunger to stick after each shot, not allowing the next projectile to be loaded. This problem can be solved by replacing the solenoid return spring with one having a spring stiffness necessary to allow the solenoid's spring return to work properly. Another issue that arises with this design is the timing of the coil switching, caused by the loading solenoid pre-firing the projectile down the barrel. If this factor isn't corrected the timing of the accelerating coil could cause the projectile to be fired backwards, slowed down or not accelerated at all. The timing can be corrected by adding an electronic switch in front of the coil to detect the projectile and trigger the coil switching at the correct time. Any of the switches described in the velocity detection section can be added to the firing mechanism to handle the timing of the projectile firing. [5]

3.8 Velocity Detection

One of the major specifications of this project is to fire a projectile with a muzzle velocity of 120 feet per second (36.58 m/sec) and in order to verify this a method of determining the projectile's velocity needs to be developed. The velocity of an object can be determined with numerous techniques some more challenging and technical than others. Some of the easier options involve setting up a separate experiment and would not be part of the actual coil gun. They include setting up a vertical or horizontal ballistic speed trap, using stop frame action recording, an acoustic recording or building a ballistic pendulum. Some of the more technical sensing methods would require designing an electronic circuit to detect the projectile using a mechanical contact, optical sensors, an electrical contact or a sensing coil.

3.8.1 Experimental Methods

The experiments can be easily setup and designed without needing to acquire a lot of extra equipment or parts. The easiest of the options would be to either setup a vertical or horizontal ballistic speed trap test. The vertical speed trap consists of using some type of target that would show the impact, to fire the projectile at. The target can be placed at any distance from the end of the barrel, the velocity is determined using equation 3-4 where D is the distance from the barrel to the target and H is the difference between the height of the barrel and the height at which the projectile impacts the target from some reference height. The horizontal speed trap follows the same principle as the vertical, the difference is the target is laid horizontally. The same equation can be used to calculate velocity where D is the distance from the barrel to where the projectile lands and H is the height that it fell. For the horizontal speed trap the problem of determining velocity is a little more difficult, primarily because a general idea of how far the projectile will travel will need to be known in order to place a target at the correct location. This may be difficult with smaller projectiles since they may be harder to follow at higher speeds. Another issue is this will most likely need to be performed outdoors and the accuracy of the measurement will be based on the ability to determine an accurate reference height via flat ground.

$$v = D \times \sqrt{\frac{9.81}{2 \times H}} \quad (3-4)$$

Some of the other options include performing either acoustic test or filming the shot, which can easily be performed in a laboratory environment. The acoustic test can be conducted using a computer and microphone placed at the end of the barrel to record the sound of the shot and the impact. Using audio software the recording can be used to determine the time between shot and impact, then the velocity can be measured knowing the distance to target. The velocity can also be determined by filming the projectile as it is shot in front of a black and white striped background. Using film editing software the film can be examined frame by frame and the distance the projectile travels can be determined knowing the width of the stripes. The distance of flight and the frames per second of the camera will be used to determine the muzzle velocity.

Another crude method for determining the velocity of the projectile is to build a ballistic pendulum. This technique was first developed by Benjamin Robbins in which he used principles of conservation of momentum and conservation of energy in order to determine the velocity of an object. This works by firing the projectile directly into a pendulum with a known mass at close range and measuring the change in height of the pendulum along the arc it travels. This experiment is a proven method and relatively easy to setup with household items such as a cardboard box weighted down and some string. Achieving accurate measurements for the mass of the projectile and pendulum, as well as the change in height of the arc are critical in determining the muzzle velocity. The arc can be measured by transferring the motion of the pendulum to a board parallel to the motion of swing using a felt tip marker. Using equation 3-5 the

muzzle velocity can be calculated, where m_p is the mass of the pendulum, m_b is the mass of the projectile and h is the change in height of the arc. [1]

$$v = \left(1 + \frac{m_p}{m_b}\right) \times \sqrt{2 \cdot 9.81 \cdot h} \quad (3-5)$$

3.8.2 Real Time Methods

While the methods above are good for determining the velocity of the projectile as an initial test, a more technical method would need to be developed to record the velocity during normal operation in real time. Some of these methods include using mechanical contacts, electrical contacts, sensing coils or optical contacts. All of these methods involve designing electronic circuits to take the measurements and perform the calculations. For all of these methods the circuit would remain relatively unchanged, only the method in which the projectile is detected changes. The mechanical contacts would probably be the easiest design to integrate into the coil gun as they should take little setup or troubleshooting. The downside of this type of contact is the fact that it is a mechanical contact that would have to protrude into the barrel so that the projectile would depress the plunger as it travels along the barrel. This may cause the projectile to slow down from the obstruction and friction due to the contact. The electrical contact is a similar method to the mechanical in that some kind of contact would need to protrude into the barrel, as the projectile itself is used to complete the electrical circuit. The downside to this design would be determining the placement of the contact to ensure that the projectile will complete the circuit without impeding its motion.

The sensing coil would be the most unobtrusive design. The coils work on the same principle as the coil for the coil gun and for this reason would be interesting to experiment with. This approach works by applying a DC biased current to the sensing coil which briefly magnetizes the projectile. This magnetization of the projectile creates a voltage spike as it enters the coil and a negative spike as it exits the coil. The main advantage of the sensing coils is that no modification of the barrel needs to be made in order to determine the projectile's location allowing the coil to be placed anywhere along the barrel and slid up and down the barrel if needed. The downsides of this approach is designing a coil that is capable of producing a large enough voltage spike that can be detected. This would require the development of some experiments to determine the necessary coil size. Another issue that might arise with the sensing coil is filtering out any magnetic interference due to the field generated by the firing coil that might produce erroneous velocity measurements.

The most widely used design is to utilize optical sensors to detect the projectile position. This design also allows for the detection of the projectile without having to actually make contact with it. This can be implemented using a photodiode and infrared sensor that will detect the projectile when the beam is broken as it passes between them. The downside of this design is the need of two sets of the

optical setup installed with a specified distance between them to start and stop a timer. In order for the optical sensors to work the barrel will need to be modified by cutting holes in it to allow the light to pass through. Not only does this add extra fabrication to the barrel it also limits the ability to adjust the placement of the sensors along the barrel if needed. Care must also be taken to remove any burrs that may be left on the inside of the barrel and to not remove too much material. Just as with the slots cut in the barrel in response to eddy currents, a non-continuous surface may impede the acceleration of the projectile, cause it to wobble or possibly even jam if not sized properly. [4]

3.9 Capacitor Type

There are many different capacitors available, each having their own advantages and disadvantages. There are several questions that can be asked about the specifications of the capacitors required. For example, should the capacitors be fixed or variable? What should the construction material be? Screw top or pinned? Size? Max voltage? Capacitance? Polarized? Cost? Etc. The requirements of the capacitor for this project will be detailed as follows.

The first specification that will be discussed is the capacitance and max voltage rating. For this application, capacitors with larger maximum voltage ratings relative to many smaller common pinned capacitors will be required. The target range for capacitance will be from 2000 to 3000 microfarads. The target range for the max voltage rating will be from 300 to 400 volts. The reason for choosing this voltage range is because AC outlet power (120V 60 Hz) will be used. This voltage will then be stepped up in order to charge the capacitors to this voltage range. Since the energy stored in a capacitor is proportional to the capacitance and voltage, this will ensure there is enough stored charge to provide enough energy to supply the magnetic field for the coil. Maximum capacitor voltage ratings are equivalent for all capacitors of the same rating, so as long as the voltage does not exceed the max voltage rating, there will be no damage to the device. The charging voltage should be kept at least slightly below the maximum rating to prevent damage from possible variations in input voltage. The maximum voltage rating does not mean that this should be the voltage the capacitors should be charged to, just the maximum they can withstand and operate properly. It would be wise to choose capacitors with higher maximum voltage ratings than they will be charged to.

The second specification discussed will be the material the capacitors are constructed from. Many capacitors that are made with film, paper, metalized, mica, and ceramic materials contain low max voltage ratings, so these will not be considered. In addition, most of these smaller capacitors are not polarized, however capacitors with larger max voltage and capacitance values are usually polarized, which is required since the current will need to flow a certain direction in the coil. Possible materials the capacitors for this project can be made from include polypropylene, Teflon, aluminum electrolyte, and supercapacitors.

Polystyrene capacitors have high voltage ratings and are resistant to breakdown. Teflon capacitors have higher stability and lower losses than other capacitors. Aluminum electrolytic capacitors have a large range of capacitance values from 1 to 47000 microfarads and voltage ratings up to 500 volts. Supercapacitors have capacitance values and are usually used as temporary replacement for batteries. These last three types of capacitors are ideal for high voltage, high capacitance applications.

Capacitance values for capacitors vary based on the tolerance. While some may contain the exact capacitance labeled, most will vary based on the labeled tolerance. Smaller capacitors vary usually by picofarads, while larger capacitors usually vary by a capacitance percentage. For example, a capacitor with a labeled capacitance of 1000 microfarads and a tolerance of 10% can range from 900 to 1100 microfarads. Tolerance is important to consider since, for this application, the energy of the capacitors, and thus the current supplied to the coil, can vary significantly with tolerance. This is important since multiple capacitors will be used and if each capacitor is on the low end of the tolerance values, this could result in (if they were all 10% below the rated capacitance values) 10% less energy. Providing too much capacitance can also be a problem since this would lead to higher energy amounts than expected, which would result in higher current and thus heat from the coil than expected. This could lead to overheating and damage to parts so this should be accounted for.

Another parameter to consider when choosing a capacitor is leakage current. Leakage current is the loss of charge from a capacitor due to the large separation of charge within the capacitor. Although this value is usually very small in smaller capacitors, it is what results in the slow discharge of the capacitor over time and can be represented as a resistor in parallel with the capacitor as shown in Figure 3-11.

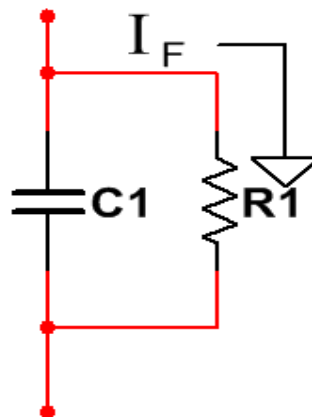

Figure 3-11 - Leakage Current Model

This leakage current can be higher (around 10 microamps) in larger capacitors

and needs to be considered in design. A graph showing the leakage current versus the temperature of a 1000 microfarad, 50 volt capacitor measured after 30 minutes is shown in Figure 3-12. In addition, the leakage current also increases with higher operating temperatures, shown in Figure 3-13. Electrolytic capacitors tend to have these higher leakage currents due to poor insulation resistance. [21][22][23]

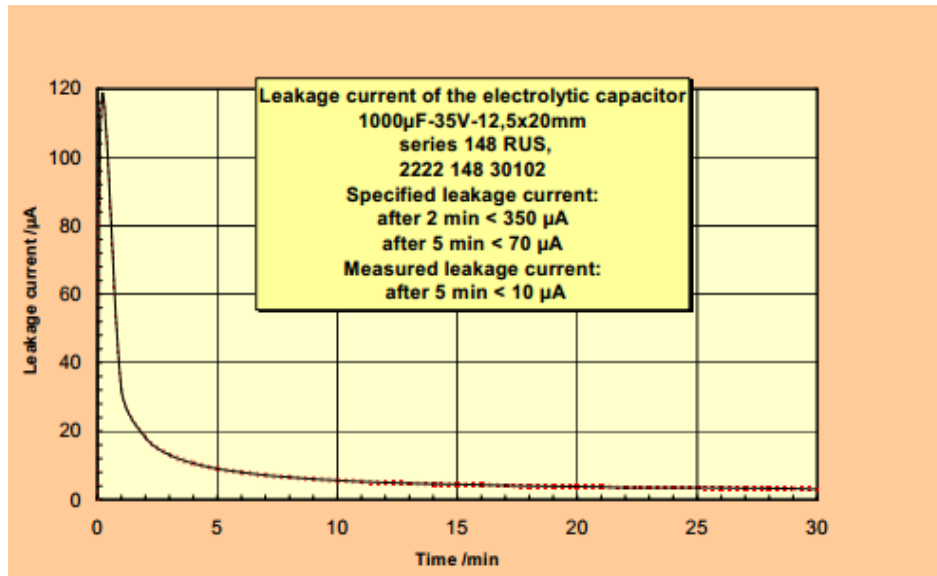

Figure 3-12 - Leakage Current vs. Time in 1000 microfarad Capacitor (Awaiting Permission from Jens Both to reprint image.)

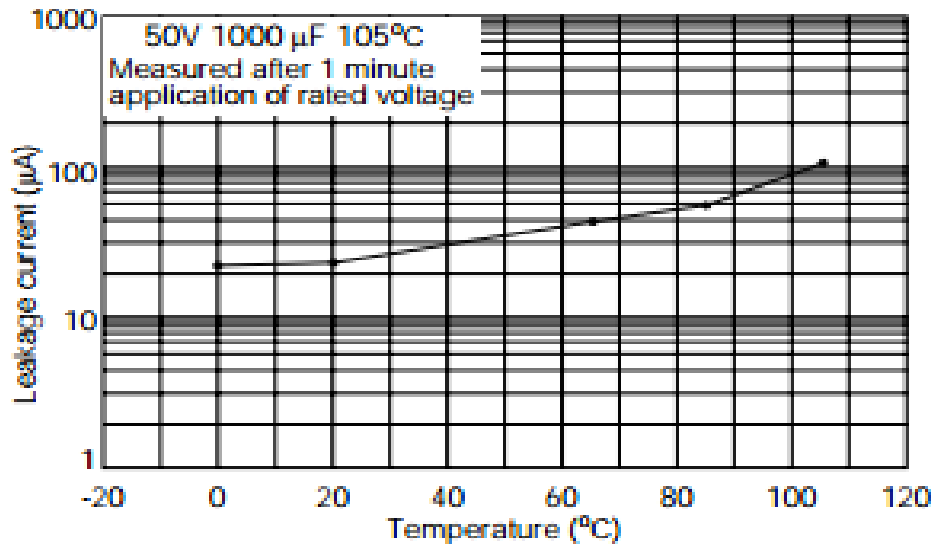

Figure 13 – Leakage Current vs. Temperature in 1000 microfarad Capacitor (Awaiting Permission from Nichicon Corporation to reprint image.)

3.10 Power Sources

3.10.1 Batteries

Batteries have many common uses in small scale electronics equipment. For this project, batteries are an option for the power source. There is a high voltage and low voltage power requirement for this coil gun. The microcontroller needs to be powered by low voltage. The coil needs to have a high voltage. A supply voltage in the standard range of five to nine volts could be easily designed for the microcontroller using amplifiers, resistors, regulators, or other components to ensure the steady supply voltage. For the coil, there would be two ways to supply the high current required for the magnetic field.

First, a battery pack could be used to charge a capacitor bank, then the capacitor bank is discharged to provide the high current. The other option is to step up the voltage supplied by the battery and use it to directly supply the current to the coil. As mentioned in the research of previous projects, most coil gun designs use capacitor banks to supply the coil current, however the battery option has the advantage of not having a charge time. However, batteries supply less power and require charging. Batteries that supply the coil current cannot supply a high enough current to launch a projectile at desirable speeds, therefore multiple coil stages have to be included in order to provide more acceleration and increase velocity. This creates the need for a switching circuit that will control multiple stages which complicates the design. While multiple coils are needed in order to reach comparable projectile speeds that are achieved from discharging capacitors, rapid firing is more easily achieved using batteries since the energy can be supplied steadily with batteries.

3.11 Power Conversion

3.11.1 AC/DC Conversion

The power source for this project will be 120 volt 60 Hertz AC signal from a standard outlet. The AC signal will need to be converted to DC in order to charge the capacitors. The practical way to convert alternating current to direct current is to use rectifiers. Commonly known rectifiers are half wave, full wave, and bridge rectifiers. Half wave rectifiers convert only half of the alternating cycles, which wastes energy, and would be impractical for this application. Full wave rectifiers convert both positive and negative alternating cycles and are commonly used in power applications. Full wave rectifiers can convert the alternating cycles to either fully negative or fully positive. For the coil gun design, it would not be wise to allow the direct current to flow either positive or negative; one direction would be necessary. This is important for safety reasons as well, since the capacitors are polarized and charging them with the opposite polarity can cause them to be damaged or explode depending on the voltage. The full wave rectifier has the advantage of having a center tap design, which eliminates the voltage drop required to operate the diodes. The diode operating voltage is usually only a problem for smaller voltage circuits.

Arguably the most useful rectifier design is the full wave bridge rectifier. This design has an advantage in that the polarity of the input doesn't matter; the output voltage polarity will be the same. The disadvantage is that the operating voltages of all the diodes are present and since there are four diodes instead of two, the required operating voltage is higher. Again, this is usually only an issue at smaller voltages since the operating voltages are very small so output voltage will not be lower than expected. The full wave bridge rectifier will be the rectifier used for this project and is shown in Figure 3-14. [24]

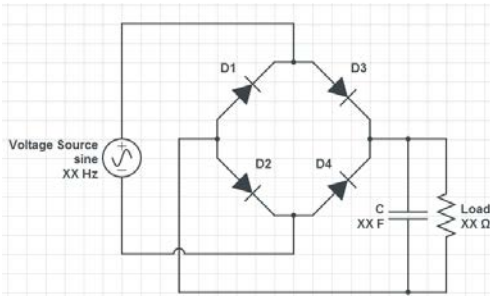

Figure 3-14 - Full Wave Bridge Rectifier

Frequency is another consideration for the power source selected. Ideally, the capacitor bank will be charged with a purely direct current source. A 60 Hertz sinusoidal source can be used, but is 60 Hertz enough cycles per second to represent a direct current source? Will the capacitor bank be charged effectively? An alternating source should not be used for charging a capacitor bank; a direct current source is needed. After the alternating current is rectified by the full wave bridge rectifier the signal is still “bumpy” because of ripple voltage. It is more effective to have a constant voltage for charging the capacitors. Common methods to reduce the ripple voltage are to use a resistor and capacitor in parallel, which is also shown in Figure 3-15. This method provides a cheap source of rectified voltage. However, for certain applications it may be necessary to provide a more reliable and accurate constant voltage. From the circuit shown in Figure 3-15 below, the ripple voltage would vary slightly. While this may not be an issue for applications that don't require high accuracy such as bulbs, fans, etc., it is important for an application such as powering a microcontroller. If the supply voltage to a microcontroller drops below the required voltage, there is a chance the device will power off and/or not operate properly. This is especially crucial if the microcontroller has volatile memory since data will be lost. Therefore, it is important to have a smooth steady supply voltage to prevent such malfunctions.

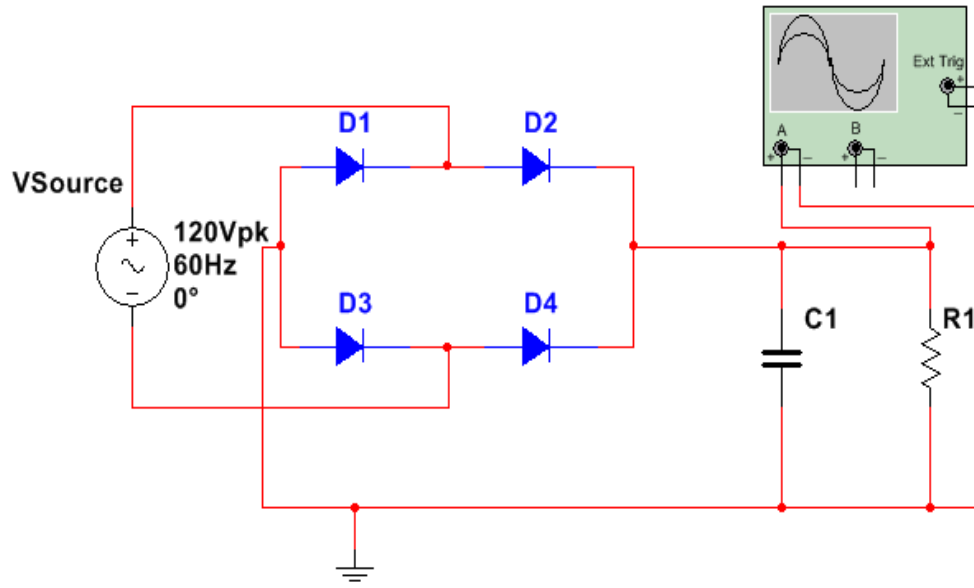

Figure 3-15 - Full Wave Bridge Rectifier Circuit with Filter

In this case a linear voltage regulator can be used. The linear voltage regulator has an input, reference, and output voltage. A current divider can be used to control the output voltage. The output voltage of this linear regulator can be found using equation 3-6 below.

$$V_{\text{out}} = V_{\text{ref}}\left(1 + \frac{R_2}{R_1}\right) + I_{\text{adj}}R_2 \quad (3-6)$$

The use of a voltage regulator will ensure the output voltage from the rectifier circuit will not contain ripple and remain constant. From the use of a circuit with a regulator as in Figure 3-16, the output voltage for this circuit will be constant. One disadvantage of the linear regulator is the operating voltage, which can be high compared to the supply power for applications that use batteries or solar. Since the power source will be a wall outlet, powering the regulator will not be an issue. The linear regulator circuit will be used for this project.

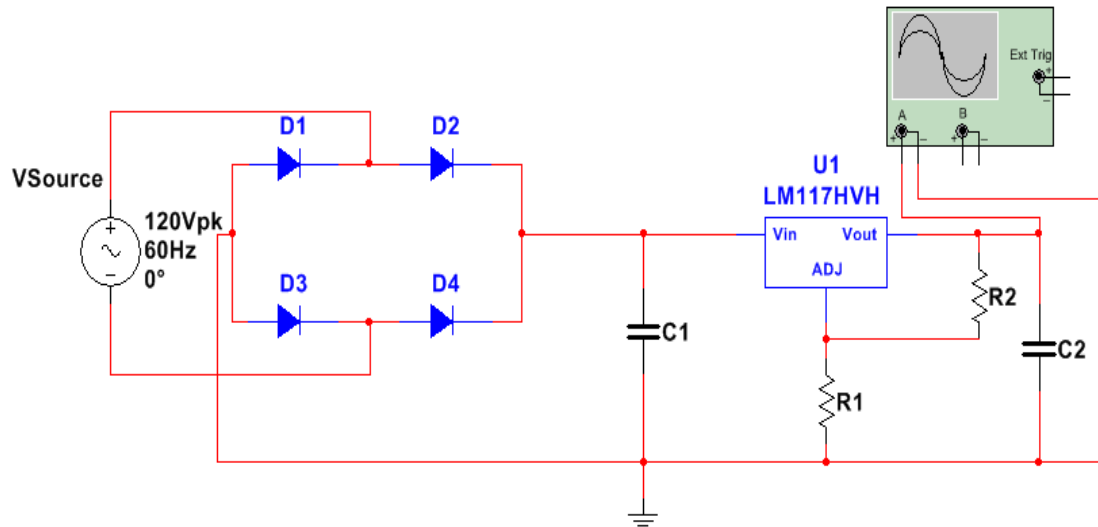

Figure 3-16 - Rectifier Circuit with Regulated Output Voltage

This project requires both high voltage (for charging the capacitors) and low voltage (for powering the microcontroller and everything else). Therefore the alternating current needs to be converted to high and low voltage direct current. The high voltage conversion will use a transformer and rectifier while the low voltage conversion will use just a rectifier and linear voltage regulator to obtain the required voltages.

3.11.1.1 AC Step-up

Transformers are used to either step up or step down an alternating voltage source. This device is used to convert power provided from power plants to high voltages in order to transfer energy with lower losses. The transformer here would be used to simply step up the voltage in order to charge the capacitor bank to a value close to the capacitors maximum voltage rating. Transformers have a wide range of voltages and power ratings. Larger power ratings, measured in volt-amps are used for higher voltage applications and can be very large, ranging from kilo to mega volt-amps. This would be impractical for this application and a smaller transformer will be required.

A practical transformer that can be used this project would require a 4 to 1 ratio and a power rating of around 500 VA. This would allow around one amp of current to flow through the output and a voltage of roughly 480 volts. The advantage of using a transformer is that no pulse width modulation is needed and the frequency of the input does not need to be considered. When using a design that implements DC to DC step up, which would most likely involve boost regulators (refer to Section 3.11.1.2), the switching frequency is important for the operation of the amplifier. However for the transformer doesn't use pulse width modulation or any kind of frequency manipulation so this simplifies the design. The frequency only needs to be considered when using a transformer for this application when the output filter is designed, however if a properly designed

filter is in place, the frequency still doesn't need to be considered.

The disadvantage of using a transformer is that they can become bulky and heavy for larger power ratings. This means added weight to the design and can make mobility and assembly more difficult. One of the goals of this design is to have a mobile coil gun turret meaning that it can be shipped and assembled in pieces with no special equipment or tools. Therefore, the use of a transformer that is large and adds weight makes this goal harder to achieve. However, the transformer that is required for this project, which is around 500 VA, are not very heavy. An Allen Bradley brand, 500 VA, single phase transformer was found from an online retailer for around 25 dollars and has a weight of 17 pounds, which will be reasonable for this design. The heaviest component for this coil gun will likely be the capacitor bank.

3.11.1.2 DC Step-up

There are multiple methods to use in order to charge the capacitor bank strictly with direct current instead of stepping up alternating current and converting it into direct current. With the advent of digital electronics becoming cheaper and more popular, using regulators has become a popular way to change voltage levels to desired values. Instead of relying on transformers, which can become expensive and bulky, regulators allow direct current to produce a larger output voltage and still remain small. This allows for a more compact circuit design and device to be created. In addition, devices that normally would be required to be attached to a wall outlet because of the high voltage or current requirements can now be powered by lower voltage batteries.

There is a common regulator that can be used in order to step up direct current. This is called a step-up regulator, also known as a boost converter. This is a DC to DC device that converts a smaller input voltage into a larger output voltage. This device contains a storage element (inductor and/or capacitor), a switch, and a diode to create pulses of current at higher voltages. When the switch is closed, the current in the inductor increases based on time constant of the inductor. This is called the storage phase and shown in Figure 3-17. After a short period, the switch is opened. At this point, the inductor tries to maintain a constant magnetic field. To do this, the current must be maintained. Since the switch is now an open and the current wants to be constant, the voltage across the switch increases until the current can conduct across the switch. This is known as the discharge phase and is shown in Figure 3-18. This greatly increased voltage to allow the current to conduct is what creates the high output voltage. Since power must be conserved, if the output voltage is 10 to 15 times the input voltage, this means the output current is 10 to 15 times lower than the input current. Devices like this have operating frequencies that can range from 50 to 250 kHz in order for the switching to be efficient. This frequency means that control (i.e. pulse width modulation) needs to be added in order for the boost converter to operate effectively. Often, a filter circuit is added to the output of these converters (consisting of a resistor and capacitor in parallel) in order to reduce the ripple voltage (refer to Section 3.11.1.1). This device would require that the control is

connected to the microcontroller or that an additional timer be added to the design in order to set the proper switching frequency. [4]

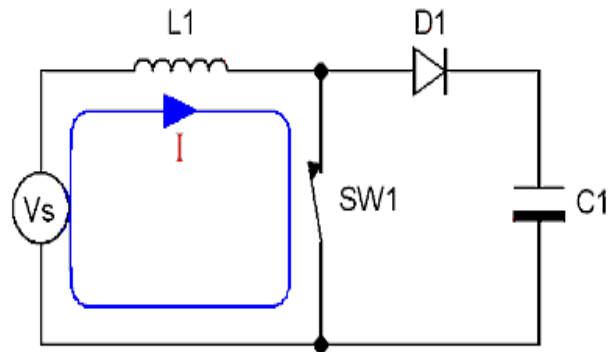

Figure 3-17 - Boost Regulator Storage Phase
(Awaiting permission from James Paul to reprint image.)

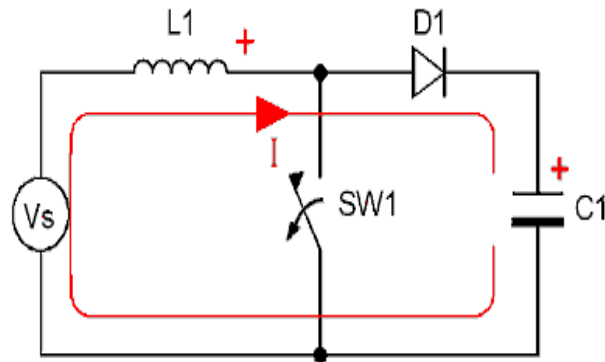

Figure 3-18 - Boost Regulator Discharge Phase
(Awaiting permission from James Paul to reprint image.)

3.11.1.3 DC Step-down

The voltage needs to be stepped down in order to supply power to low voltage parts of this project, i.e. the microcontroller. A DC to DC device to consider is the step down regulator, also called a buck converter. The principle of this device is the same as that of the boost regulator, however the voltage of the output is lower than that of the input while the current of the output is greater than that of the input. When the switch is closed, as in Figure 3-19, the diode is reverse biased and the current rises steadily in the inductor. This is called the storage phase. During this phase, the capacitor becomes charged and the voltage across the capacitor and load becomes steady. Once the switch is opened as in Figure 3-20, the diode becomes forward biased. The voltage source becomes shorted and the voltage on the inductor becomes the opposite polarity as the magnetic field collapses. The voltage on the load now becomes less than the source. This is called the discharge phase. This device also requires high frequency switching in order to operate effectively. The use of pulse width modulation is normally used to operate this device. Again, the microcontroller would be able to perform

this operation. [25]

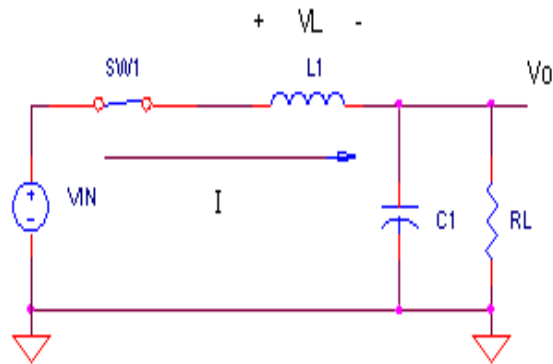

Figure 3-19 - Buck Converter Storage Phase Equivalent Circuit
(Awaiting permission from eCircuits to reprint image.)

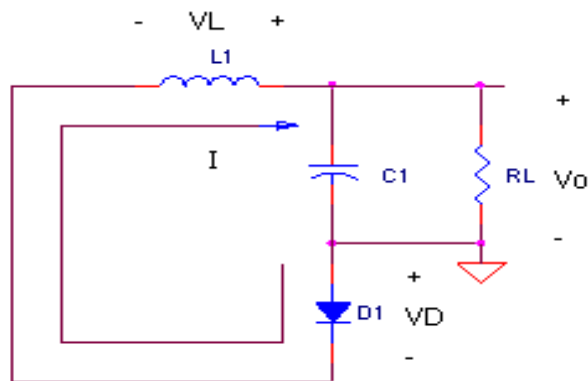

Figure 3-20 - Buck Converter Discharge Phase Equivalent Circuit
(Awaiting permission from eCircuits to reprint image.)

A Buck converter is a strong consideration over a linear regulator since Buck regulators are very efficient. Many of these devices have efficiencies reaching 95 percent. A linear regulator wastes a lot of power since the device must be powered and throws off excess power as heat. Therefore, the use of a more efficient device such as the buck converter would be desired. However, the power supplied to the microcontroller is very small compared to the power supplied to the coil. This means that while using the buck converter in order to power to the microcontroller is more efficient, which has practical uses in small, compact electronic devices, the power saved is almost irrelevant compared to the power that will be consumed by the coil. Therefore the use of a buck converter doesn't have a great advantage over the linear regulator in this project. [26]

4.0 Design

4.1 Projectile

As with any coil gun project the objective is to accelerate an object for a desired purpose, whether for a practical application as the energy source to accelerate a nail gun, rocket, to study the electromagnetic principles or simply for fun. A coil gun by nature is very inefficient, on average 1-2 %, and as a result maximizing efficiency is a primary concern for any project. The required field generation system and design changes, relative to the desired object to be propelled. For this reason the design must begin with the projectile and everything else will be designed in order to accelerate that particular object alone.

4.1.1 Magnetic Properties

To be able to accelerate a projectile using an electromagnetic field the projectile must be constructed of a ferrous material for the magnetic flux lines to induce an accelerating force on the projectile. By examining a particular materials hysteresis curve, it can be seen how a material's magnetic lux density begins to saturate as the applied magnetic field increases for this reason there is a diminishing return for the design of the coil and the resulting magnetic field it generates. A materials permeability and saturation point will determine the magnetic field that can be applied to the projectile before resulting in a reduced efficiency. Ferrous materials that will be considered for this project include iron, steel, nickel and some alloys. Table 4-1 below shows the magnetic properties of the materials being considered for use as a projectile. To determine which material will be best for this project the cost, availability and the ability to machine the material to a desired shape will all need to be considered to make a final decision. By calculating the energy and magnetic field required to accelerate the projectile to a desired specification a determination will be made in regards to any limitations with muzzle velocity that may be encountered for a particular projectile size and material properties. Even though utilizing other materials may allow for a more efficient design, for this project a ¼ inch diameter steel rod will be chosen to use as the projectile for the design of the components that make up the coil gun, this decision is based primarily on availability, price and ease of fabrication. The steel rod can easily be purchased online or at most home improvement stores at a cheap price.

Material	Relative	Saturation	Flux
----------	----------	------------	------

	Permeability (μ_r)	Density (Tesla)
Cold Rolled Steel	2,000	2.10
Nickel	600	0.64
Iron (99.8% pure)	5000	2.15
Iron (99.96% pure)	280,000	2.15
MO/Ni Supermalloy	1,000,000	0.80

Table 4-1 – Magnetic Properties of Ferromagnetic Materials

4.1.2 Projectile Fabrication

The size and shape of the projectile can have just as much effect on the muzzle velocity as the materials magnetic properties. The size of the projectile has a direct relationship to the saturation point of the material. For this reason a spherical shaped projectile, like a bb makes for a very inefficient design. In order to achieve a sufficient magnetic flux density the projectile should have a length at least 3 times longer than its diameter. As can be seen in Figure 4-1 the length of the projectile as related to the coil's length has an effect on the coil gun's efficiency as well, this relationship will be used to size the coil's length. During the prototype stage the rod can easily be cut to various lengths to find the optimum projectile that will result in the greatest muzzle velocity.

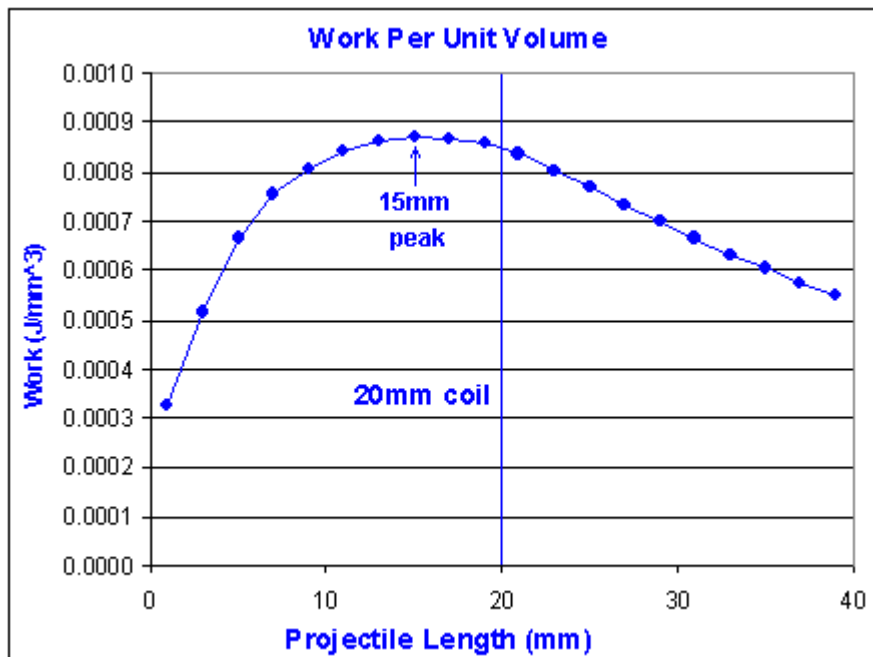

Figure 4-1 – Efficiency with a Fixed Coil Length and Varying Projectile Length (Reprinted with permission from Barry Hansen.)

Since a smooth steel rod is being used as the projectile, another factor effecting

efficiency is the buildup of eddy currents in the projectile that produce magnetic fields that oppose the fields generated by the coil. Since the projectile is a ferromagnetic material this is unavoidable, one option that is available is to add slots along the surface by machining the steel dowel to eliminate a smooth path for the eddy currents to flow. For this project an assumption will be made that the eddy currents will not have a great impact on efficiency since access to the equipment or skills to customize the steel dowel is not available. To improve the projectile's accuracy simulations can be run to determine the best aerodynamic shape and the resulting shape can be turned using a metal lathe and machined to create fins to improve stability during flight. For this project there is no benefit to creating these simulation models as it is outside the scope of this project and access to the skills or equipment to fabricate an optimized projectile is not available. There would also be no benefit to contracting someone else to design and fabricate as it is not within the budget. The projectile design will be limited to a smooth steel dowel due to financial concerns and lack of access to advanced fabrication methods. During the prototype phase of the project an attempt will be made to turn the nose of the dowel to a rounded nose as opposed to a flush cut, to check for improvements in accuracy or flight time. [1][4]

4.2 Barrel

The barrel of a coil gun performs an additional function not needed in a traditional gun, creating an air gap. The presence of the air gap is what allows the magnetic field to accelerate the projectile without it the projectile would just be turned into a permanent magnet. The air gap can only be created if the barrel material has a relative permeability around one, this gives a permeability close to that of air.

A non-ferrous metallic tubing is an option for this design as it offers the needed air gap and offers great structural integrity. Although for this design metal tubing is eliminated as an option for various reasons, one being with that design custom fabrication machine tools would be needed to eliminate the build-up of eddy currents. Other concerns with using a metal barrel is excessive build-up of heat that a metal barrel might cause and the fact that the barrel could become a conductor posing a hazard to users. Since one of the major design specifications of this coil gun is the ability to fire multiple rounds in succession, excessive heat is a major concern and using a metal barrel could create a problem not allowing the coil to coil efficiently. Extra steps would need to be taken to try to cool the barrel and coil, which would be difficult since only surface cooling options are available and would not have an effect on cooling the barrel or interior of coil.

Another function a barrel performs for typical firearms is providing accuracy and velocity. For this type of gun, the barrel length cannot increase velocity because there is no gases to be trapped behind the projectile during firing. The barrel length can also provide improved accuracy as it allow the projectile to stabilize along a constant direction during acceleration. The barrel can also be rifled to

increase accuracy. This can be done using machine tools or can be done by hand in this case, since PVC is being used and is soft enough that grooves can be cut using a handmade die. The projectile being used in this project probably isn't soft enough to swage upon acceleration. As a result the projectile most likely will not be engaged by the rifling, therefore the rifling will have little or no effect on the accuracy for this design. Rifling will not be used in this project because of the little or no effect it would have on projectile accuracy.

For this project a PVC barrel will be used because it has a relative permeability close to one and allows for easy fabrication. With this choice the barrel might need to be held secure with supports because it does not offer the same structural integrity as a brass or other metal tubing would offer. The PVC tubing used will have an inner diameter of ¼ inch, which is determined by the ¼ in steel rod being used as the projectile. Its outer diameter is set by the choice of tubing and is based on standard PVC tubing available. The length of tubing will most likely be around 18 inches to allow the projectile to stabilize during acceleration, while not being too bulky or awkward to maneuver. The length can be adjusted during testing to optimize accuracy and ease of control.

4.3 Force and Energy Characteristics

The magnetic field is generated by current flowing through a coil and calculating the force and energy required to accelerate a particular object to a specified velocity is the first step in determining the required magnetic field. The coil gun will be designed to operate in two firing modes, a single shot high velocity mode (Mode 1) and semi-automatic modes (Modes 2&3) that fires with a lower velocity. Table 4-2 contains the results of the force and energy calculations needed to meet the design specifications for firing mode 1 and Table 4-3 contains the results for semiautomatic modes 2 and 3. Design calculations based on the higher energy high velocity mode will be used to determine the coil parameters needed to generate magnetic field. For the semi-automatic mode the main design concern is with the possibility of excessive heat build-up, since the coil will not be allowed to cool naturally between shots. For the high velocity design an estimated projectile mass of 6 grams with a targeted muzzle velocity of 120 feet per second (36.58 m/sec) will be used. The projectile's acceleration period is calculated using an acceleration distance equal to half the length of the coil, 0.0254 m. Rearranging and combining equations 4-1 and 4-2 gives equation 4-3, which is used to calculate the acceleration time, this is also the duration that the magnetic field should be applied.

$$d_a = \frac{1}{2}at^2 \quad (4-1)$$

$$v = at_a \quad (4-2)$$

$$t_a = \frac{2d_a}{v} \quad (4-3)$$

Equation 4-4 gives the projectile's acceleration, based on the velocity specification and the calculated duration of the magnetic field.

$$a = \frac{v}{t_a} \quad (4-4)$$

The force required to accelerate the 6 gram projectile to a muzzle velocity is given below in equation 4-5 and can be converted to energy in joules with equation 4-6.

$$F = ma \quad (4-5)$$

$$E = Fd_a \quad (4-6)$$

Equating 4-7 and 4-8 for kinetic and potential energy respectfully gives equation 4-9 assuming a 2 % efficiency factor, which can be used to calculate the optimum capacitance and voltage values, which are used to calculate the coil's current with equation 4-10.

$$KE = \frac{1}{2}mv^2 \quad (4-7)$$

$$PE = \frac{1}{2}CV^2 \quad (4-8)$$

$$KE = e(PE) \quad (4-9)$$

$$I = C \frac{dV}{dt} \quad (4-10)$$

Equation 4-11 gives the coil's impedance, which will be used in equation 4-12 to determine the coil's time constant, which is the first half-wave of the firing period's oscillation.

$$L = \frac{2PE}{I^2} \quad (4-11)$$

$$\tau = \pi\sqrt{LC} \quad (4-12)$$

To allow for an easier design and fabrication of the coil gun, the same capacitors will be used for the semi-automatic mode and will be charged to the same voltage. Doing this will also simplify the calculations and by using the same equations above the energy and force generated can be determined. The design of the semi-automatic mode will be based on using the same 6 gram projectile, in which one 1800 microFarad capacitor will be charged to 334 V to generate the magnetic field used to accelerate it. The current flow through the coil during modes 2 and 3 will also be calculated using equation 4-10 and the value will be used to help determine the conductor size needed to handle the heat generated by multiple shots.

Description	Variable	Value	Units
Mode 1 Design Calculations			
Acceleration Time	t_a	1.389	msec
Projectile's Acceleration	a	26340.5	$\frac{m}{sec^2}$
Force	F	158.043	N
Energy	E	4.014	J
Kinetic Energy	KE	4.014	J
Potential Energy @ 2% Efficiency	PE	200.714	J
Capacitance – 2 @ 1800 μ F each	C	3600	μ F
Voltage	V	333.93	V
Coil Current	I	865.637	A
Coil Impedance	L	0.536	mH
LC Time Constant	τ	4.364	msec

Table 4-2 – Mode 1 Force and Energy Calculations

Using the specified capacitor and voltage values allows the energy requirements to be determined, which can be used to calculate the projectile's acceleration and muzzle velocity with equations 4-13 and 4-14 respectively.

$$a = \frac{F}{m} \quad (4-13)$$

$$v = \sqrt{\frac{2KE}{m}} \quad (4-14)$$

The projectile's acceleration time will be calculated using equation 4-15 and will be compared to the capacitor time constant to check for magnetic pull-back.

$$t_a = \frac{v}{a} \quad (4-15)$$

From the results in Tables 4-2 and 4.3 the coil can be designed to meet the energy requirements, with the material properties that can produce the intended muzzle velocity. It can be seen that the coil needs to be designed such that it can handle a current of 865 A for a period of 1.5 milliseconds and a current of 306 Amps for 10 milliseconds in order to operate in either mode 1 or modes 2

and 3. The coil also needs to have an inductance around 0.5 milliHenries for the capacitors to discharge fast enough to limit the pull-back effect on the projectile. [1]

Description	Variable	Value	Units
Design Specifications			
Capacitance – 1 @ 1800 μF	C	1800	μF
Voltage	V	333.93	V
Modes 2 & 3 Design Calculations			
Potential Energy	PE	100.358	J
Kinetic Energy @ 2% Efficiency	KE	2.007	J
Force	F	79.022	N
Projectile's Acceleration	a	13170.4	$\frac{m}{sec^2}$
Projectile's Muzzle Velocity	v	25.866	m/sec
Acceleration Time	t _a	1.964	msec
Coil Current	I	306.052	A

Table 4-3 – Semiautomatic Modes 2 & 3 Force and Energy Calculations

4.4 Coil

The design of the coil was first attempted by using the magnetic field equations and Matlab scripts to simulate the magnetic flux density versus coil dimensions. The analysis of the coil was investigated using equations found at www.netdenizen.com for practical magnet design and with equation 4-16, which can be used to calculate the magnetic field in a finite air core solenoid. The assumption was made that the magnetic field is strongest at center of the coil where x_1 and x_2 being the magnitude of the distance to the point of measurement from each end of the coil are the same, thus simplifying to equation 4-17, which is illustrated in Figure 4-2.

$$B = \frac{x_2 \mu_0 I N}{2(r_2 - r_1)} \cdot \ln \frac{\sqrt{r_2^2 + x_2^2} + r_2}{\sqrt{r_1^2 + x_2^2} + r_1} - \frac{x_1 \mu_0 I N}{2(r_2 - r_1)} \cdot \ln \frac{\sqrt{r_2^2 + x_1^2} + r_2}{\sqrt{r_1^2 + x_1^2} + r_1} \quad (4-16)$$

$$B = \frac{\mu_0 j L}{2} \cdot \ln \frac{\sqrt{r_2^2 + (\frac{L}{2})^2} + r_2}{\sqrt{r_1^2 + (\frac{L}{2})^2} + r_1} \quad (4-17)$$

Where:

- μ_0 = the permeability constant
- j = the current density in the coil in Amps/unit area
- L = length of the coil
- r_1 = the inner radius of the coil
- r_2 = the outer radius of the coil

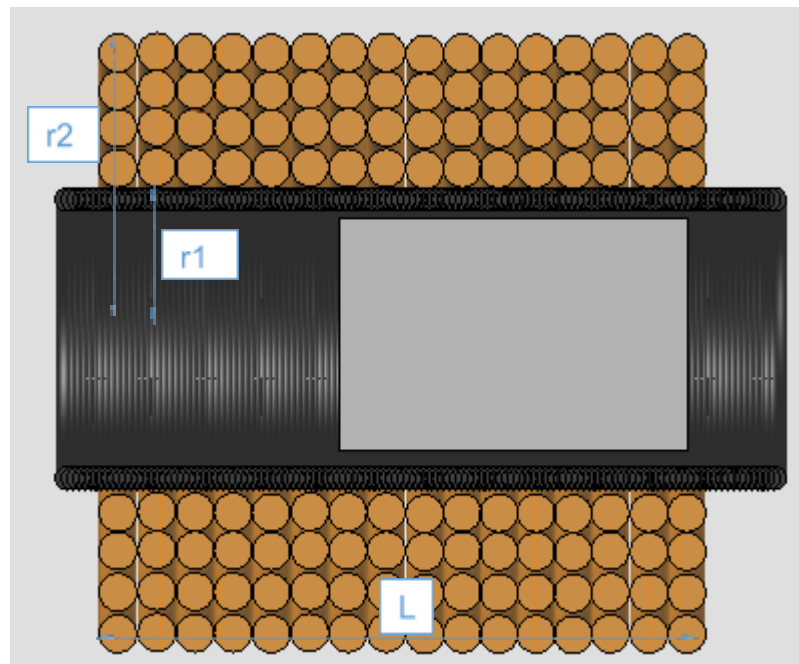

Figure 4-2 – Cross-Section of Coil Showing Parameters for Calculating B Field

The equations above proved difficult in helping to determine the dimensions of the coil. One issue is the injection of the projectile into the calculations and how to handle the changing magnetic field due to the travel of the projectile. After days of trying to develop equations and model the coil, as well as further research and the realization that the magnetic field strength is less important than the coil's LC time constant, the above equations were set aside, but they will be used to study the magnetic field of the completed design. Instead the results of the calculations performed in section 4.3 will be used to design the coil.

4.4.1 Dimensions

4.4.1.1 Diameters

Just as with all other factors of this design the coil's diameter starts with the projectile being used and thus the barrel that controls the direction of its acceleration. For this project the barrel that is being used has an outside diameter of 14 millimeters and this establishes the inside diameter of the coil. This inner diameter of the coil is chosen to be 14 millimeters to eliminate any additional air gap between the coil and projectile that would minimize the magnetization of the projectile. This diameter also allows the coil to be easily fabricated by directly winding the coil onto a jig made from a piece of the firing tubing. This jig would allow the ability to fabricate multiple coils that can be slid off of the jig and directly onto the barrel without any air gap.

Determining the outer diameter is not as straight forward and has to be calculated. The idea is to choose dimensions that would maximize the magnetization of the projectile while staying within the inductance value of 0.536 milliHenries calculated from the energy to accelerate the projectile to the specified velocity. Utilizing the equations found at www.netdenizen.com the magnetic field can be optimized based on the relationships found in equations 4-18 and 4-19 below. The magnetic field will be maximum given a specified input power when alpha is equal to 3 and beta is equal to 2.

$$\alpha = \frac{r_2}{r_1} \quad (4-18)$$

$$\beta = \frac{1}{2 \cdot r_1} \quad (4-19)$$

While, beta cannot be optimized for this project given that r_1 is based on the projectile and barrel diameters alpha can be optimized. Using the coil's inner diameter of 14 millimeters the outer diameter can be chosen to optimize alpha and the magnetic field. This optimization sets the outer diameter of the coil to be 42 millimeters. [27]

4.4.1.2 Length

The length of the coil was assumed to be 50.8 millimeters in section 4.3 to calculate the acceleration distance and the resulting force necessary to accelerate the projectile to a specified velocity within the assumed distance. The calculations for force and energy resulted in an inductance value of 536 microHenries for the coil. With the optimized inner and outer diameters of the coil calculated to be 14 and 42 millimeters respectfully. The calculated coils inductance and equation 4-20 will be used to create a Matlab script that will determine the length of the coil, this value will be compared with the assumed length to see if there are any similarities. The Matlab script will contain a function that takes inputs of conductor size, coil diameters and length. The number of turns will be in terms of the inputs and the function will output the inductance and resistance of the given coil. [1]

$$L = \frac{0.8(NA)^2}{6A+9B+10C} \quad (4-20)$$

Where:

- N = the number of turns
- A = the average radius of the coil
- B = length of the coil
- C = the coil thickness

4.4.2 Conductor

The choice of the conductor being used for the coil will be based on the functionality of coil fabrication, current carrying capacity, the heat losses and heat dissipation. Any conductor can be used to make the coil, but the best type of conductor to use is magnet wire. Magnet wire is not actually magnetic, but the name comes from the fact that it is used in electromagnetic machines, like transformers, motors, inductors and speakers. Magnet wire consists of either an aluminum or copper conductor with a very thin insulation, this allows for a tighter wound coil which increases the magnetic flux density. The size of the conductor will determine the amount of current the coil can handle and how the heat dissipates, establishing the firing rate and acceptable muzzle velocities.

4.4.2.1 Conductor Type

Magnet wire differs from a traditional conductor in that it is annealed and coated with a different kind of insulation, allowing thinner insulations while still maintaining insulation breakdown voltages and temperature ratings. The annealing process is performed by heating the conductor above critical temperature and slowly cooling back to room temperature. The annealing process helps to eliminate defects within the crystalline structure of the material, softening it by improving the material's ductility. By improving the ductility of the conductor a tighter wound coil becomes possible, which improves the magnetic flux density the coil can generate increasing the efficiency and improving the workability of the conductor allowing for an easier coil fabrication. Magnet wire can be either round, rectangular, square, square with beveled edges or have a flat cross-section. The square shaped cross-section allows for a tighter fit of the coil's conductor, giving a denser field as there is less air gap around the conductor. This is often used in large motors and transformers, but is rarely available in the smaller conductor sizes used for this design.

Magnet wire can be made of either copper or aluminum. An aluminum conductor is a softer material allowing improved workability during fabrication, this is about the extent of the advantages to using an aluminum conductor. Aluminum has a higher resistivity than copper so for that reason an aluminum conductor must be about one in a half times larger than a copper conductor used for the same application. Aluminum also has a lower melting temperature which limits the current pulse that can be applied and the duration of current flow, which would reduce the magnetic field generated and capabilities of the coil gun. Aluminum

magnet wire is traditionally used in large electromagnetic machines and the copper magnet wire is better suited for the small compact coil being designed for this application. For all the reasons listed above a copper magnet wire with a round cross-sectional area will be used in the fabrication of the coil.

4.4.2.2 Insulation Type

The insulation of the magnet wire provides a tough, continuous layer at various temperature ratings to prevent shorting of the coil. The advantage of magnet wire over a traditional conductor with a plastic or rubber insulation is a thinner insulation without reducing the voltage and temperature ratings of the insulation, which also allows for a tighter wound coil. The thinner insulation reduces the distance between turns, improving the flux density as it is directly related to the number turns per layer for a given coil length. Magnet wire is identified by its NEMA rating, which rates the insulation by its thermal capacity. Table 4-4 lists the thermal classes of magnet wire by their temperature rating and available insulating materials.

Thermal Class	Insulating Materials
105 °C	Polyvinyl Acetal-Phenolic, Polyurethane/Polyamide/Polyvinyl Acetate
130 °C	Polyurethane/Polyamide
155 °C	Polyurethane, Polyurethane/Polyamide, Glass Fibers
180 °C	Polyurethane, Polyurethane/Polyamide, Modified Polyester-Imide, Modified Polyester-Imide/Polyamide, Polyester/Polyamideimide/Bond Coat
200 °C	Polyester/Polyamideimide, Glass Fibers
220 °C	Polyester, Polyester/Polyamideimide, Aromatic Polyamide Paper
240 °C	Aromatic Polyimide

Table 4-4 – Magnet Wire Insulation Ratings and Properties

The different insulating materials allow for the use of magnet wire in different applications depending on environment and use. The choice of insulation type is based on temperature rating, flexibility, abrasion resistance, chemical resistance, moisture resistance, heat shock and whether solder terminations are desired among other specialty features and applications. With this design most of the environmental concerns will not be considered when choosing conductor insulation as operation will primarily be limited to a laboratory environment with no exposure to outside elements. The main concern will be the flexibility of the insulation to allow for a tightly wound coil and a temperature rating of at least 180 degrees Celsius, to allow for a balance between a coil that can handle higher energies while keeping the cost of the wire relatively inexpensive. A polyester or polyester/polyamide insulation will be used as they are often used in the fabrication of coils, offering high thermal resistance, flexibility and abrasion

resistance. [28]

4.4.2.3 Conductor Size

The standard current ratings for conductors do not apply for this design as they are based on constant current, whereas the current flow through the coil will only be present for a few milliseconds. The approach that will be taken to determine the appropriate conductor size is to use the Onderdonk equation below, which determines the wire size used in fuses. Equation 4-21 allows the ability to determine the amount of time it will take a conductor of specific size to melt, based on the amount of current applied and ambient temperature.

$$S = \left(\frac{A}{I}\right)^2 \times \log_{10} \left(\frac{(T_m - T_a)}{(234 + T_a)} + 1\right) \div 33 \quad (4-21)$$

Where:

- S = duration of current flow in seconds
- A = the wires cross-sectional area in circular mils
- I = the amount of current in Amps
- T_m = the melting point of the conductor (1084 °C for copper)
- T_a = the ambient temperature in °C

The Onderdonk equation will be evaluated using a Matlab script with input parameters for wire size, applied current and ambient temperature to perform calculations of the conductor's melting time for both operating modes. For the semi-automatic mode the duration of current flow will be considered to be the total time of all the shots. Table 4-5 contains the results of the Onderdonk equation showing the melting time and number of possible shots given a specified current, wire size, mode of operation and ambient temperature. The number of shots will be based on the projectile's acceleration time determined earlier, a value of 2 milliseconds will be used to allow for any variance between the ideal design and coil testing. While performing the Matlab calculations it was determined that changing the ambient temperature from the average room temperature of 27 °C to 35 °C, the temperature of an average summer day in Florida, resulted on average to only a 1 to 2 percent decrease of melting time for the conductor. Since the ambient temperature across a relatively narrow spectrum has little effect on the calculation results a temperature of 27 °C was used in the calculations.

The results of the possible number of shots is quite surprising, as one would assume that while operating the coil gun the temperature increase for each additional shot would have an exponential response. These results are far above any goals for a firing rate that is desired, so the actual possible firing rate will be experimentally determined during testing by firing successive shots while monitoring the temperature increase. This will be discussed in greater detail later in the prototype testing section. For this project a 14 AWG magnet wire will be used as it offers a relatively long melting time for the energies that will be present while still allowing for the fabrication of a compact coil.

Conductor Size	Applied Current (A)	Melting Time (s)	Time (s) Derated 20%	Max # of Shots
Mode 1 – High Power				
12 AWG	865	1.215	0.972	N/A
14 AWG	865	0.480	0.384	N/A
16 AWG	865	0.190	0.152	N/A
18 AWG	865	0.075	0.060	N/A
20 AWG	865	0.030	0.024	N/A
Mode 2 – Semi-Auto				
12 AWG	306	9.705	7.764	3882
14 AWG	306	3.839	3.071	1535
16 AWG	306	1.518	1.215	607
18 AWG	306	0.601	0.480	240
20 AWG	306	0.238	0.190	95

Table 4-5 – Results of Onderdonk Equation for Conductor Melting Time

4.4.3 Coil Simulations

4.4.3.1 Inductor Simulator

Some very handy simulation tools created by Barry Hansen are available at www.coilgun.info, the inductor simulator seen in Figure 4-3 is a Java source code that calculates the inductance and resistance of a coil for given dimensions and conductor sizes. Using the given diameters of the coil to meet the optimized physical parameters of the design and the conductor size determined in section 4.4.2, the length of the coil can be determined that will give the inductance required to dissipate the potential energy stored in the capacitors. Another advantage of the simulator is that it also calculates the number of turns, total wire length, weight of coil and other parameters that help design subsequent aspects of the project as well as the fabrication of the coil.

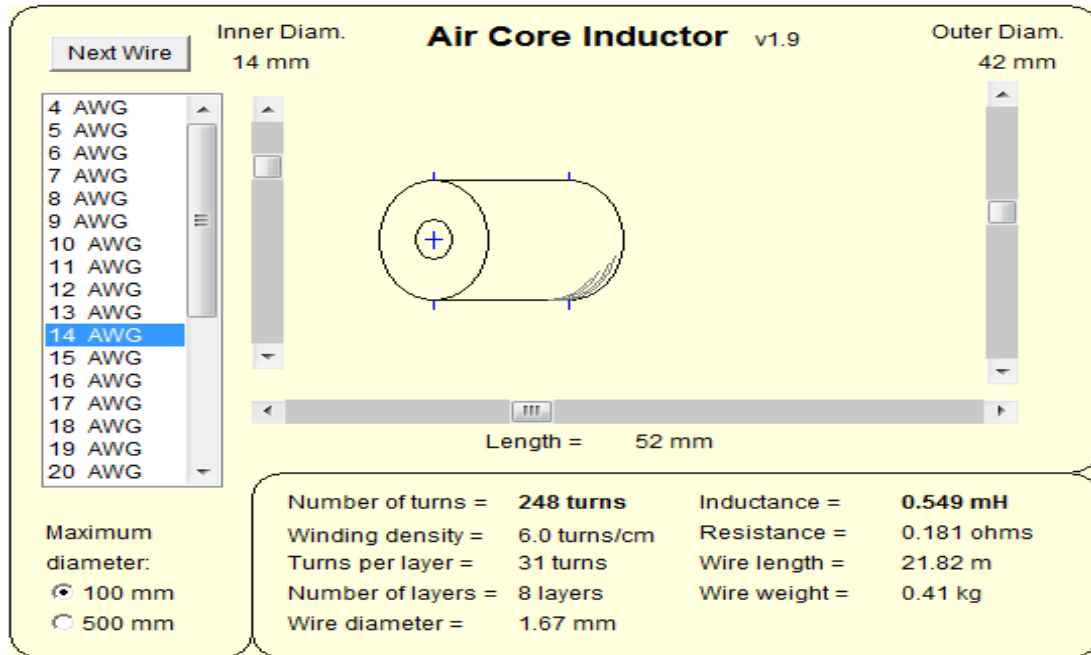

Figure 4-3 – Inductor Simulation to Determine Coil Length
(Reprinted with permission from Barry Hansen.)

4.4.3.2 RLC Simulator

The RLC simulator is also a Java applet made available at www.coilgun.info that can be used to calculate the peak current and the duration of the current pulse. The coil's inductance and resistance values determined from the inductor simulator are entered into the simulation along with the capacitance of the energy source. The simulation was performed for both the high power mode and the two semi-auto modes, the results can be seen in Figures 4-4 and 4-5 respectfully.

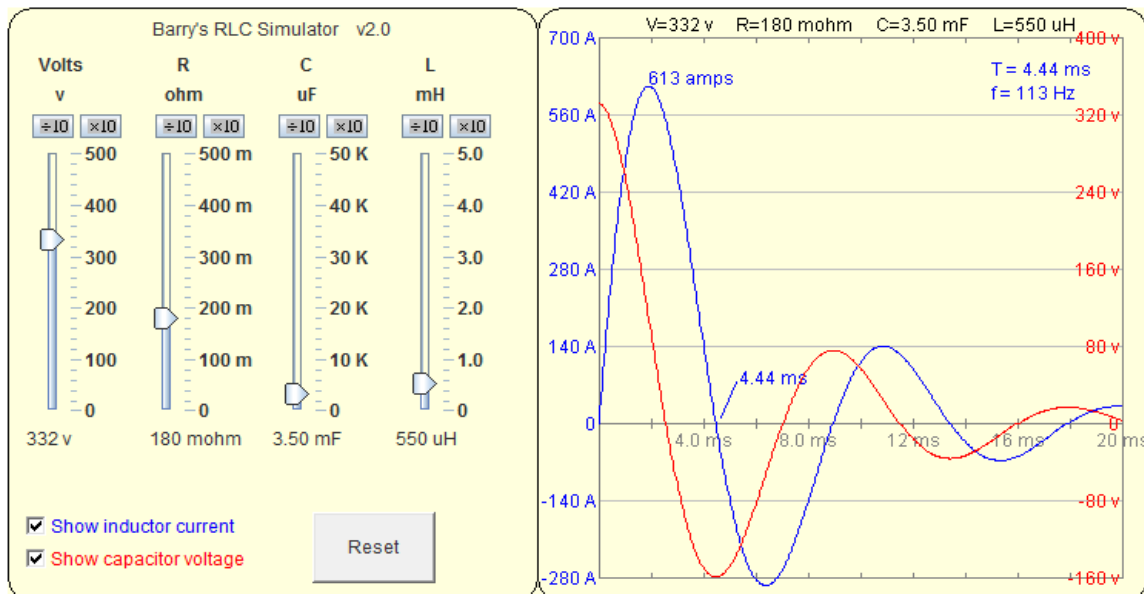

Figure 4-4 – RLC Simulation of Mode 1 Showing Current Pulse and Duration

(Reprinted with permission from Barry Hansen.)

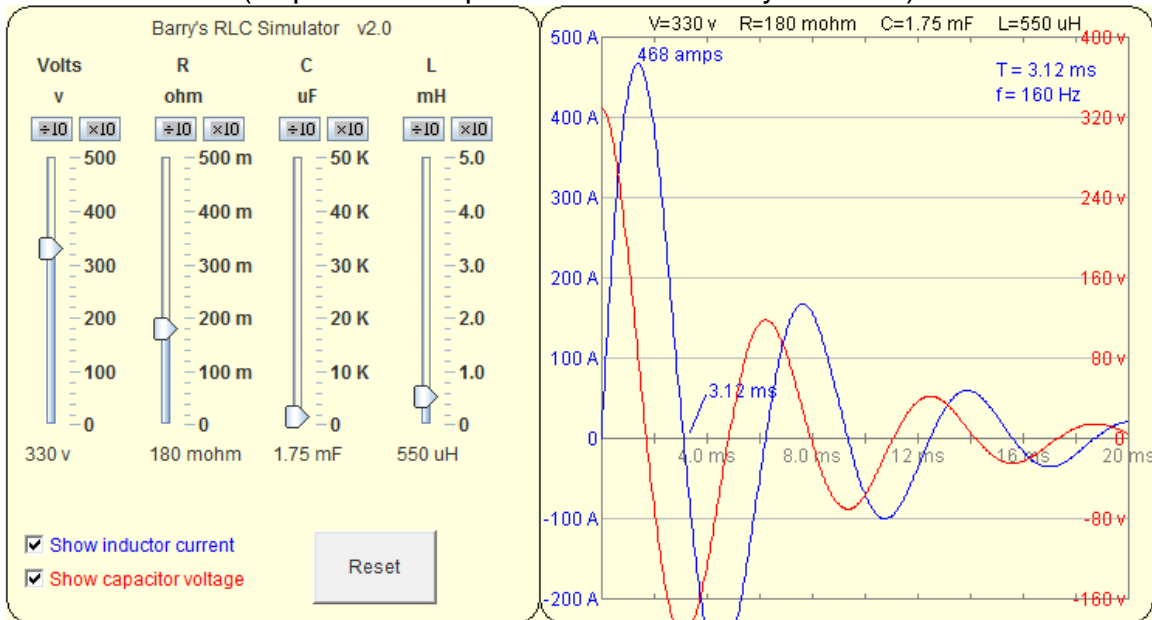

Figure 4-5 – RLC Simulation of Modes 2&3 Showing Current Pulse and Duration
(Reprinted with permission from Barry Hansen.)

The results in Table 4-6 of the inductor simulator will be compared with the Matlab calculations to determine the optimized coil design. Using the optimized coil design the results of the RLC simulator, in Table 4-7 will be compared with the calculations in section 4.3 to verify viability of assumptions made in the coil design.

Description	Variable	Value		Units
Coil Parameters				
Inner Diameter	r_i	14		mm
Outer Diameter	r_o	42		mm
Length	l	52		mm
Wire Size	d_w	14		AWG
Results		Matlab	Simulator	
Inductance	L	0.4597	0.549	mH
Resistance	R	0.170	0.181	Ω
Total Length	l_{wire}	21.05	21.82	m

Table 4-6 – Coil Properties

Description	Variable	Values		Units
Energy Calculations		Mode 1	Modes 2/3	
Current Pulse	I	865.6	306.1	Amps
Pulse Duration	t_a	4.364	4.364	msec
RLC Simulator				
Current Pulse	I	613	468	Amps
Pulse Duration	t_a	4.44	3.12	msec

Table 4-7 – Properties of the Current Pulse for each Firing Mode

4.4.4 Heat Dissipation

The heat generated by the current pulse through the coil is the factor most affecting the ability to fire projectiles rapidly in the design of the coil. Since the current pulse is very short with a coil gun it can be assumed that no natural cooling of the coil takes place during the pulse duration. The most practical way to cool the coil for a project of this size and budget is to use a computer fan to displace the heat generated. Computer fans take a 12 volt DC input to power the fan, whereas the control of the fan's speed varies with model. The CFM rating of a fan indicates the flow of air the fan can deliver, the air flow can be temperature controlled, digitally controlled or manually controlled with a potentiometer. The fans can operate on input voltage lower than their rating, but the CFM capabilities will diminish. For this project the determination of whether or not to implement a fan into the design will be made during the testing phase of the project in order to determine what the actual increase in temperature will be. If necessary a fan can be easily added to the system to help dissipate heat, a computer fan with a high CFM rating would be chosen and the control circuit would be designed for the fan to operate all the time at max speed.

Temperature increase in the coil is due to the heat losses in the conductor. The heat loss in Joules can be calculated with equation 4-22 using the current pulse, the resistance of the coil and the acceleration time. The issue that arises with trying to calculate the rise in temperature is that the conductor heat losses cause the resistance of the coil to increase. The temperature rise is based on the ratio of resistances and the temperature coefficient of copper α_c , which is 0.393 percent per degrees Celsius. Equation 4-23 can be used experimentally to determine the temperature rise by measuring the coil's resistance before and after the current pulse. Table 4-8 contains the results of the coil's heat losses for the first shot, the potential energy of the system and the percent of energy that is lost due to heat, which can be calculated using equation 4-24. As can be seen in

the results, one of the main reasons coil guns are so inefficient is the amount of energy that is lost due to heat and this explains the 2 percent efficiency that is traditionally achieved for most high energy coil guns. This further illustrates the importance of optimizing the magnetic field and current pulse duration in order to achieve an efficient coil gun, The actual rise in temperature will be determined in the testing stage of this project by measuring the change in resistance, the advantage of this approach is the temperature can be calculated after each successive firing to determine the maximum possible firing rate before damaging the coil. After performing the test the determination of whether or not a CPU fan needs to be added to the design will be made.

$$E_j = I^2 R t_a \quad (4-22)$$

$$\Delta T = \frac{\left(\frac{R_2}{R_1} - 1\right)}{\alpha_c} \quad (4-23)$$

$$\%_{\text{loss}} = \left(1 - \frac{PE - E_j}{PE}\right) \times 100 \quad (4-24)$$

Description	Variable	Value	Units
Heat Loss	E_j	176.678	J
Potential Energy of System	PE	200.714	J
Energy Loss Due to Heat	$\%_{\text{loss}}$	88.02	%

Table 4-8 – Heat Losses in Coil

4.5 Magnetic Field

The magnetic field that exists in a coil gun during the firing of a projectile is very difficult to calculate due to the relationship between the coil and projectile as it moves through the coil. Finite Element Magnetics or FEM models are a good tool for modeling the magnetic field of the coil gun. QuickField offers a student version of their FEM software, this software does have limitations on the complexity of the system being modeled, but will be useful in illustrating and understanding how the magnetic field in the coil changes depending on the position of the projectile. A Matlab function was created using equations 4-16 and 4-17 to examine the magnetic flux density of this particular design. The function allows the ability to change the coil parameters, current pulse and point at which the flux density will be measured. This code can only be used to understand the flux density of the air core coil itself and is not able to incorporate the effects of the projectile. Table 4-9 contains the results of the Matlab function for the designed coil at the midpoint and an assumed firing position in front of the coil, of 8 millimeters.

Description	Variable	Value	Units
Magnetic Flux at Midpoint	B	0.0747	T
Magnetic Flux at Firing Position	B	0.0295	T

Table 4-9 – Magnetic Flux of Coil with Without Projectile

The QuickField FEM modeling program was used to model the magnetic field and flux density of the designed coil incorporating the steel projectile. The model can be created using the top cross-section of the coil and projectile due to the symmetry of the system. Figures 4-6 to 4-8 show how the magnetic field of the coil changes as the projectile passes through the coil. The created FEM model of the coil gun was then used to determine the magnetic flux density in the coil and projectile, Figure 4-9 shows the strength of the flux density concentrated in the projectile. This figure illustrates the importance of the current pulse duration since the majority of the magnetic flux is concentrated in the projectile. [1]

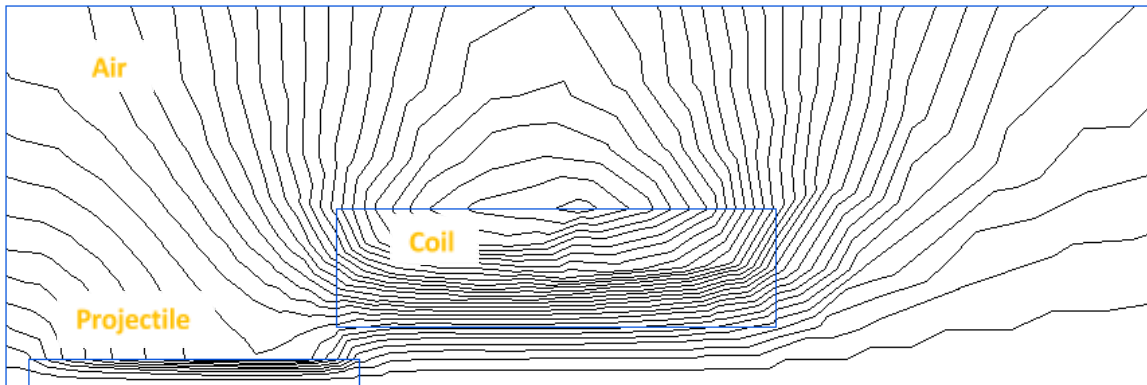

Figure 4-6 – Magnetic Field with Projectile at Firing Position

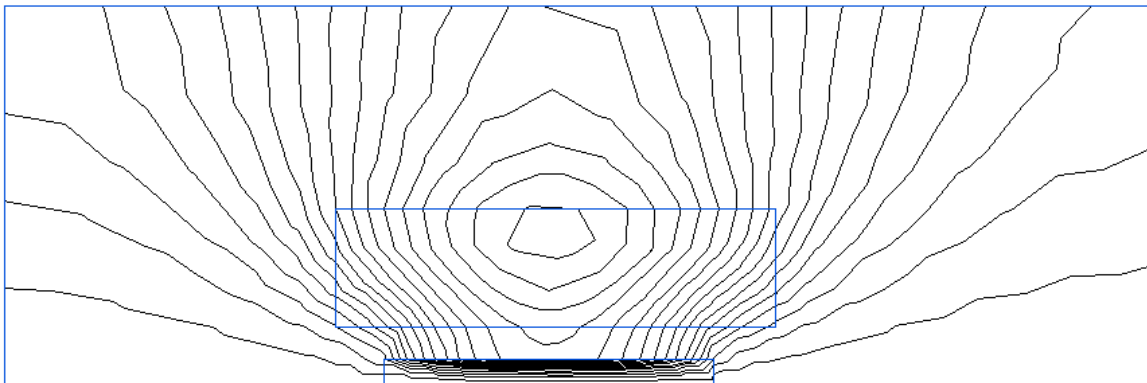

Figure 4-7 – Magnetic Field with Projectile at Center of Coil

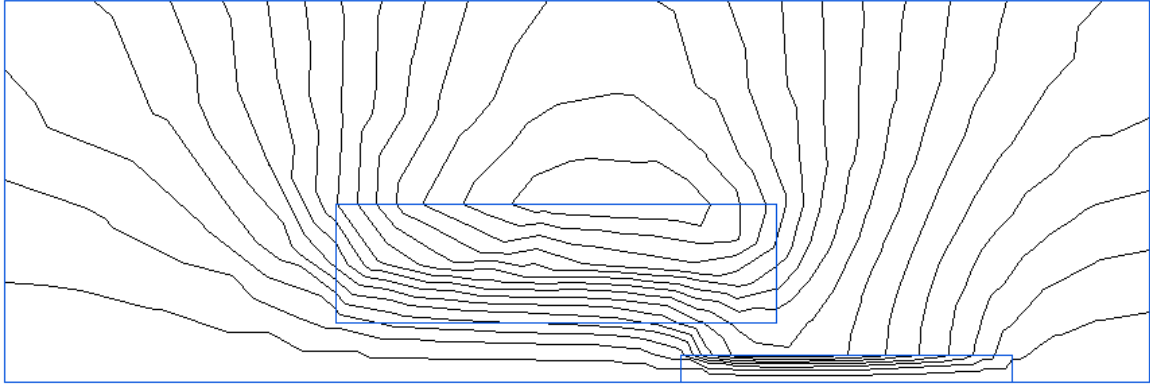

Figure 4-8 – Magnetic Field with Projectile Exiting Coil

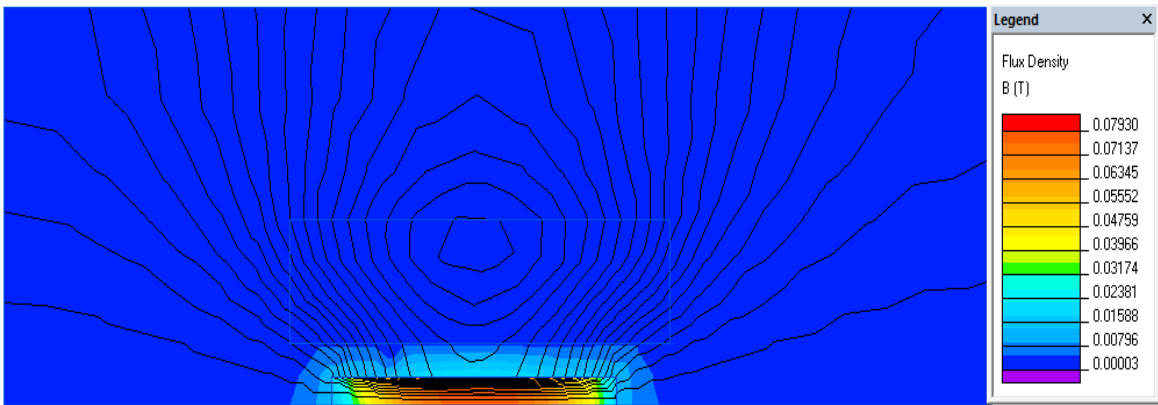

Figure 4-9 – Magnetic Flux Density in Coil Gun

4.6 Automatic Reload

The reloading of the projectile will be handled by connecting a gravity fed box magazine to the top of the barrel. The magazine will be large enough to accept 6 projectiles and the barrel will be modified by cutting a slot the length of the projectile determined to produce the best results for muzzle velocity. The placement of the magazine in relation to the coil's entry point will also be determined in the testing stage, by finding where the projectile exhibits the greatest velocity. The projectile magazine will be constructed with acrylic sheets to limit the weight of the coil gun. To keep the design simple, a push-pull solenoid will not be incorporated into the design due to the added weight, additional mechanical design and troubleshooting, and the additional control circuit that would be needed to sense the projectile's position for coil timing.

4.7 Velocity Detection

Being that one of the main design parameters was to achieve a muzzle velocity of 120 feet per second a method of measuring the velocity of the projectile needs to be designed. In the early stages of prototype testing the velocity will be estimated experimentally in order to determine if the coil gun is operating

adequately. After the coil gun is operating satisfactorily an electronic circuit will be incorporated into the design to measure and display the velocity of each shot. For this project two optical sensors will be used to establish a speed trap to calculate the projectile's velocity and display it. This design was chosen because of the inexpensive and readily available components, as well as the amount of information available of previous applications incorporated into a coil gun. This type of design will also allow the ability to prototype, test and troubleshoot the system before adding it to the coil gun. The speed trap will work by cutting holes in the barrel to allow the transmission of an Infrared LED beam to an IR phototransistor mounted on opposite sides of the barrel. Figure 4-10 shows the circuit that will use a comparator to determine if the projectile is blocking the beam by comparing the output of the phototransistor to a reference voltage. The output of the two comparators will be connected to inputs of the microprocessor to start and stop a timer. Using the distance between the two optical sensors the processor can calculate the muzzle velocity.

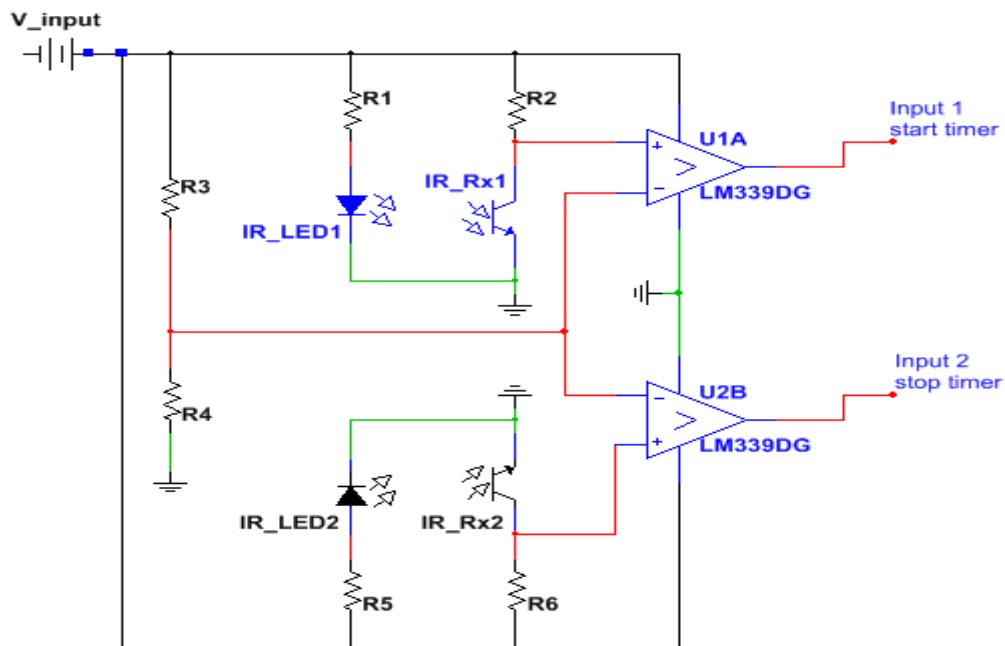

Figure 4-10 – Optical Speed Trap Circuit

4.8 Automated Turret

The turret subsystem design for the project needs to add a dynamic feature to the automated coil gun project. The turret must give the operator the ability to aim the coil gun remotely. This will provide for a couple of unique benefits that would be rather limiting without a turret. It provides the ability for the coil gun to change position which allows the operator to change the object they are targeting or continue to target a single object as it moves. The remote operation allows for the change in position of the coil gun without having a person physically reposition the system. This provides for convenience of use, greater adaptability in repositioning, and most importantly safety.

4.8.1 Power and Control

The first thing to consider for the design of the turret system's power and control are the overall project requirements. Several of these requirements affect the way the turret must function and therefore affect the design. Some of the requirements that fall into this category are:

- Operator can control the system from a safe area at a safe distance
- Coil gun can target objects in a 180 degree range on the horizontal plane
- Coil gun can target objects in a 45 degree range on the vertical plane measured in the positive direction from the horizon
- Change in position must be executed in a smooth motion, not jerky

After research into the options available the DC servo motor will be the motor used to power the movement of the turret subsystem. This type of motor best suits the needs and requirements of the project. Many different models of DC servo motors are available. The model that will be used must meet the torque requirements of the system.

In order to find the right size servo motor, the torque required to move the weight of the coil gun subsystem must be known. The following are torque calculations done for each of the two servo motors to accommodate movement in the required range of motion. Table 4-10 lists the components that the servo motors will be moving and their weights are used for finding the force variable for torque in equation 4-25. The values used for the displacement vector variable in Table 4-11 and in Table 4-12 are the distances calculated from the pivoting point of the servo motor to the center of mass for the objects that are moving.

Component	Maximum Weight
Coil	1.5 lbs.
Frame	1.5 lbs.
Projectile	2 oz.
Barrel	4 oz.
Fan	5 oz.
Hardware	6 oz.
Camera	7 oz.

Table 4-10 – Component Maximum Weights

Total maximum weight (with 6 projectiles) = 5 lbs. 2 oz. = 5.125 lbs.

$$\text{Torque: } \tau = r \times F = |r||F|\sin\theta \quad (4-25)$$

Torque for the vertical movement servo:

Description	Variable	Value	Units
Displacement Vector	r	4	in.
Force Vector	F	5.125	lbs.
Angle Between Force & Displacement Vectors	θ	45	degree ^o

Table 4-11 – Torque Equation Variables

$$\tau = |4||5.125|\sin(45) = 14.496 \frac{\text{lbs}}{\text{in}} = 231.931 \frac{\text{oz}}{\text{in}}$$

Torque for the horizontal movement servo:

Description	Variable	Value	Units
Displacement Vector	r	2	in.
Force Vector	F	5.125	lbs.
Angle Between Force & Displacement Vectors	θ	90	degree ^o

Table 4-12 – Torque Equation Variables

$$\tau = |2||5.125|\sin(90) = 10.25 \frac{\text{lbs}}{\text{in}} = 164 \frac{\text{oz}}{\text{in}}$$

Specific requirements were made for the range of motion to ensure there is a safe zone for the operator and others. The specified range also ensures the maximum projectile distance can be reached by allowing a vertical angle of up to 45 degrees to be used. The key component to control the movement of the turret is the closed-loop control that is used by DC servo motors. The motors receive a pulse width modulated signal for control of their position. The pulse width will be determined by the microcontroller based off the operator's input for the desired position. The microcontroller will use a time period of 20 milliseconds to send a pulse to the servo motor. The width of the pulse determines what angle the servo will rotate towards.

For the servo that controls the horizontal motor a 1.5 millisecond pulse width will be used for the neutral position. A 1.0 millisecond pulse width will be used as the minimum and will rotate the servo 90 degrees from neutral. A 2.0 millisecond pulse width will be used as the maximum and will rotate the servo 90 degrees from neutral in the opposite direction. The pulse width position for the horizontal motor control is pictured left in Figure 4-11.

For the servo that controls the vertical motor a 1.5 millisecond pulse width will be

used for the neutral position. The same 1.5 millisecond pulse width will be used as the minimum. This will make the neutral position the same as the minimum position which is parallel to the ground, not allowing the coil to be aimed into the ground. A 1.75 millisecond pulse width will be used as the maximum and will rotate the servo 45 degrees from neutral in the positive vertical direction. The pulse width position for the vertical control is pictured right in Figure 4-11.

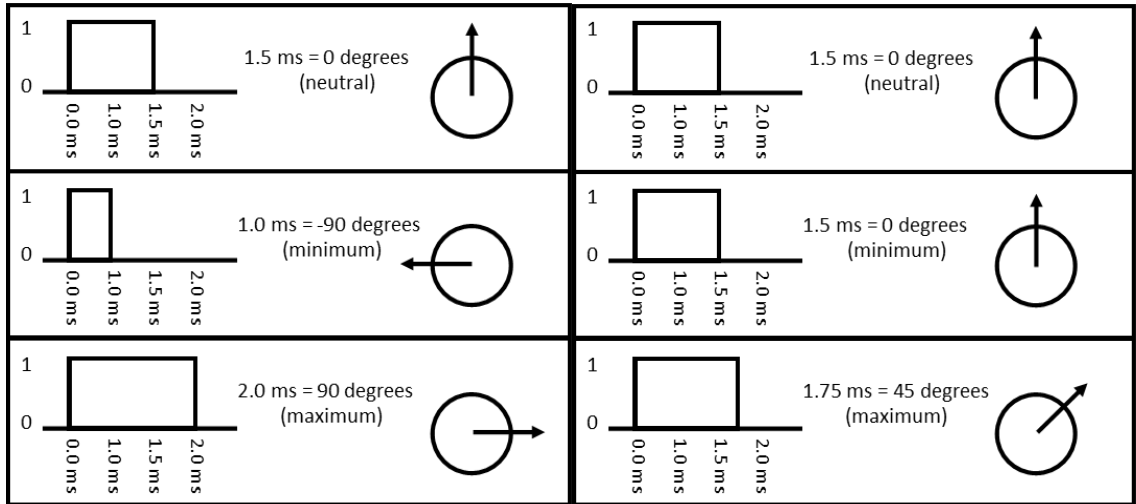

Figure 4-11 – Horizontal Motor Control (left), Vertical Motor Control (right)

Servo motors require three lines to operate; control line, power, and ground. The control lines that carry the PWM signal to the servo motors will come from the GPIO pins on the microcontroller. The power and ground lines will also be supplied from the microcontroller's GPIO pins. The GPIO pins will be separated into several sections. One section will address the power needs including the voltage needed by the servo and the ground line. The power line will transmit 4.8, 6, or 7.2 volts depending on the rating of the servo motor that is chosen. These three voltages are the voltages most commonly used on typical hobby servo motors. Another section of GPIO pins will supply PWM signals that are needed. Each servo will have a dedicated PWM line.

4.8.2 Mounting Hardware

The project requirements that were listed in section 4.7.1 that had to be considered for power and control design also have to be accounted for in the design of the turret mounting hardware. The hardware parts that will be moving have to allow for the specified range of motion and for smoothness in its movement. The hardware to be used will include a rotational part for the panning movement, a hinged part for the tilting movement, a stationary base, a mounting platform for the coil gun, and accommodations for wiring.

The panning hardware will be used in conjunction with the servo motor that will be controlling the coil gun movement in the horizontal range of motion. This combination will allow for smooth rotational movement. The panning hardware

gives the coil gun a full 180 degree range of motion in the horizontal plane. It also offers a rigid platform that is flat on top so that it is conducive to having additional hardware mounted on top. The base of the panning hardware can be tapped and drilled for custom mounting. The tilting hardware will be used in conjunction with the servo motor that will be controlling the coil gun movement in the vertical range of motion. The tilt bracket along with the servo motor allow for the specified 45 degree range of motion in the vertical plane. This bracket also offers rigidity to the tilting motion while still allowing for smooth movement. The tilting bracket has both a smooth top and bottom to provide easy mounting capabilities.

The base of the automated turret will provide a stabilized base for the mounting of the panning hardware, tilting hardware, and coil gun. It also gives the coil gun some elevation off of the ground. The panning hardware is mounted directly on top of the stabilized base. The tilting bracket is mounted directly on top of the panning hardware. The coil gun will be mounted indirectly on top of the tilting bracket. The design of the coil gun does not provide a sturdy place for mounting. This is due to the barrel and coil being round in its shape. To address this, a frame will be constructed around the barrel and coil to create a flat surface. This will make it easier to mount the coil gun onto the turret tilt bracket. It also makes the system as a whole much sturdier.

Another aspect that must be taken into consideration when designing the automated turret system is the wiring. The system will use a couple of custom designed wiring harnesses for organization and to keep wires from getting tangled when the turret is in motion. The organization also will help in the prevention of wires getting pulled on and loosened from their connections. Wiring for both of the servo motors will be contained within a single harness. This will include the control, power, and ground for each of the servo motors. The second harness will contain wiring for the coil of the gun, a control line for the fire signal, and optical sensor line, and the camera's USB cable. The wiring harnesses provide an additional benefit of being aesthetically pleasing as opposed to random, loose wires. These benefits are accentuated by covering each wire harness with a braided expandable flex sleeve.

4.8.3 Position Feedback

Once again the project specifications and requirements shape the design of another system. Position feedback is implemented in the servo motor control to ensure that the coil gun remains aimed in the direction specified by the operator. This provides for the safe operating area noted in the requirements. It also verifies that the turret can maintain and stay within the specified ranges of motion in each direction. Lastly, position feedback can help with the smooth motion of the turret.

The position feedback will implement the theory of a fully closed-loop system. The loop will start with the microcontroller giving a PWM position command to the

servo control circuit. The servo control circuit will take the input and produce a drive current to the motor. A potentiometer will turn with the motor to provide position feedback to the servo control circuit and also the microcontroller. The fully closed-loop path described here can be seen in Figure 4-12. With position feedback going to the servo control unit, it can check that signal with the input from the microcontroller to inspect for errors. By also closing the loop back to the microcontroller several advantages are gained. One advantage that is now gained is the microcontroller can verify if and when the desired servo motor position is reached. Another advantage gained with this method is the programming for the microcontroller is easier. With the feedback, code does not have to be written to track the most recent position command that got sent to the servo control circuit. If the position of the servo needs to be known, the input on the microcontroller from the potentiometer can be used.

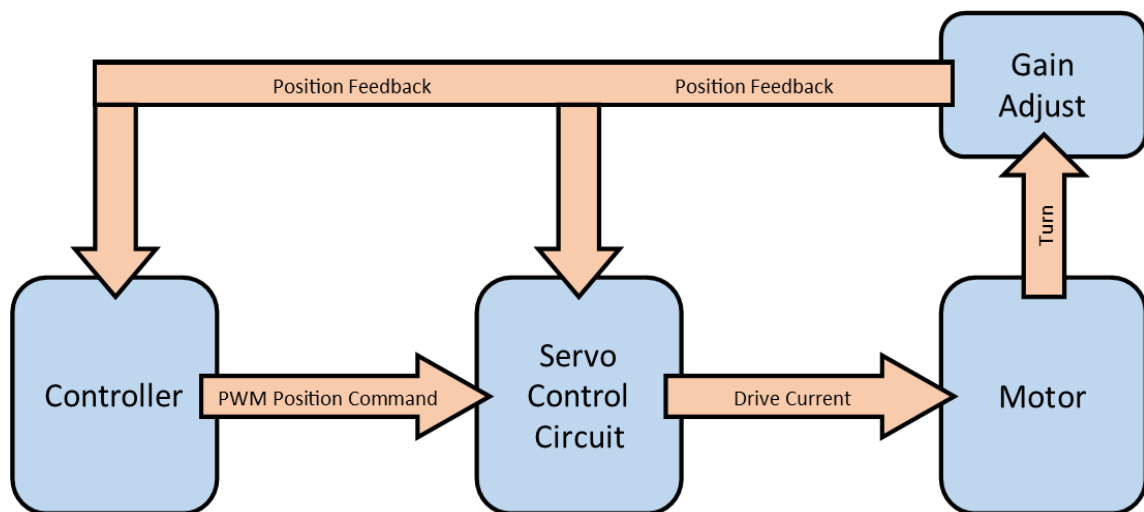

Figure 4-12 – Fully Closed-loop Feedback

4.9 PCB Components

The system control board will be made with a base that is a custom designed PCB. The PCB will have several components on it. Each component will be used to accomplish a specific task of the project as required by the system specifications. The components will be added to the system control board using a combination of surface mounted components and through-hole components. Through-hole offers an advantage to the testing and prototype stages as it is easier to make adjustments and replacements. Surface mount is used because it offers the advantage of being more space efficient. With it a higher component density can be achieved on a smaller circuit board.

4.9.1 Wireless and USB

The Wi-Fi module on the microcontroller is the communications interface between the microcontroller and the operator's mobile device. It will transmit commands from the operator to the microcontroller and if needed transmit the video feed from the microcontroller to the mobile device. The Wi-Fi network processor will use IEEE 802.11 b/g specification standards for the implementation of the wireless network and it will operate at a 2.4 GHz frequency. This will meet the projects requirements for range and data rate with the 802.11b protocol allowing up to 11 Mbit/s at up to 115 feet and the 802.11g protocol allowing up to 54 Mbit/s at up to 125 feet. The network processor will have an embedded IPv4 TCP/IP stack which will specify the format, address, transmission, route, and reception of the data. It will communicate with the microcontroller by using the Serial Peripheral Interface (SPI) at up to a 16 MHz clock speed. SPI operates as full-duplex to allow communication between the network processor and the microcontroller in both directions simultaneously. This communication interface can be seen in Figure 4-13 where SPI_CLK is the serial clock output from master, SPI_CS is the chip select output from master, SPI_IRQ is the interrupt request, SPI_DOUT is the data output to master, and SPI_DIN is the data input to master. The Wi-Fi module will operate on a power supply of 3.3 volts.

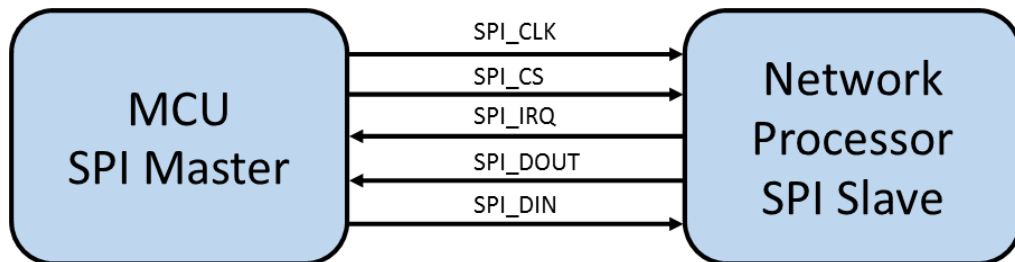

Figure 4-13 – Serial Peripheral Interface

The USB module on the PCB will be able to serve a dual purpose. It will be used as a communications interface between the computer that is used for programming the software and the microcontroller. It can also be used to relay the video feed from the webcam to the microcontroller. The interface will be USB 2.0 compatible. In order for this communication to work the interface will implement a USB to TTL serial UART converter which will be on a small PCB attached to the USB port. This small PCB will be USB powered when connected to an external computer and no other power will be required. When not connected to an external computer, the module will be powered by 3.3 voltage source from the microcontroller. Six pins will be used to connect the USB PCB to the microcontroller and PCB. Table 4-13 shows the six pin assignment.

Name	Description
GND	Device ground supply pin.
VCC	3.3 volts.
CTS#	Clear to send control input.
RTS#	Request to send control input.
TXD	Transmit asynchronous data output.
RXD	Receive asynchronous data input.

Table 4-13 – USB PCB Pin Assignment

4.9.2 GPIO Pins

The general purpose input and output pins will supply the interface for communications between several important systems. The pins will be separated into two main groupings or ports. One will be an input set of GPIO pins and the other will be an output set of GPIO pins. The processor will have the ability to enable or disable any of the pins as needed. Each of the pins will be set up for a designated function. These functions will include sensor input, PWM, voltage output, ground, light-emitting diode (LED) output, and trigger output.

4.9.2.1 Input

A port of GPIO pins will function as one of the input interfaces to other subsystems. The input will be used by the microcontroller to monitor the status of these peripherals. The data will be used for analysis and to make adjustments as necessary. Considerations had to be made in order to determine whether an input should be designated as analog or digital. GPIO pins designated as input will be used for position feedback, power system sensors, and optical sensors. A visual representation of these pins can be seen in Figure 4-14.

Position feedback is one important signal that will be seen at the input port of pins. One pin will be used for the position feedback of the servo motor controlling the horizontal motion and a second pin will be used for the position feedback of the servo motor controlling the vertical motion. Both of these pins will be receiving PWM signals and therefore will be designated as digital input pins. This input will be relayed to the microcontroller and will be used to verify if and when each motor has reached the last position command sent.

A set of optical sensors will be used on the coil gun to feedback information regarding the projectiles to the processor. The feedback signal produced from the optical sensors is in the form of a voltage. To accommodate for this type of signal a digital voltage input pin will be used. The interface GPIO pin between the optical sensors and processor will relay the signal to allow the data to be used to stay up to date on system status regarding the projectiles.

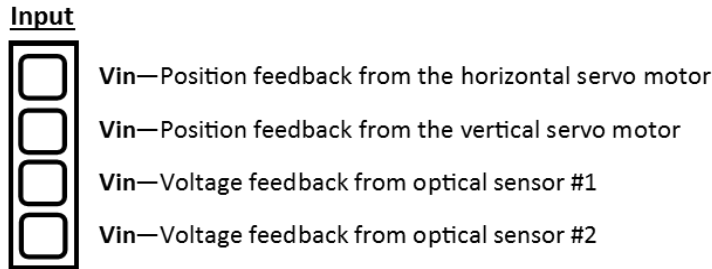

Figure 4-14 – General Purpose Input Pins

4.9.2.2 Output

A second port of GPIO pins will be used as an output interface between the processor and some of the peripherals. These output pins will be used by the microcontroller to execute critical system functions as well as supply power to certain peripherals. The pins will serve several different functions including PWM, LED operation, power output, and ground pins. Each pin will be designated to perform a specific function and interface with a specific subsystem. A visual representation of these pins can be seen in Figure 4-15.

Two output GPIO pins will be used for the position control of servo motors. Each motor will receive a signal from a separate pin. The signal used for position control will be a PWM signal. Therefore, these two pins will be designated as digital PWM output pins. The microcontroller will use these two pins to send PWM signals to each servo motor for the execution of position commands given by the operator of the system.

An LED will be used as a visual representation for the status of the capacitors in the power subsystem. When the capacitors are charged to an amount sufficient for a projectile to fire, the LED will light up. The LED will require two GPIO pins for operation. One pin will be used to supply a voltage between 3.0 and 5.0 volts depending on the specifications of the exact LED that is chosen. The voltage will be applied to the LED circuit to enable enough current flow for the light to illuminate. The LED will be turned on and off with respect to the state of the GPIO pin; high state will be on and low state will be off. The state of the pin will be controlled by the processor sending either a logical 1 (high) or 0 (low). To complete the circuit a ground pin will also be used from the GPIO port.

Several GPIO pins will be specifically set to function as power and ground pins. Both of the servo motors, along with both of the optical sensors, and the LED will each need a ground pin. The LED will need a GPIO pin for power that will be set to a constant voltage and toggled between states as needed by the processor. Each of the two servo motors will have a designated GPIO pin assigned to supply a constant voltage of 4.8, 6.0, or 7.4 volts depending on the specifications of the exact servo motor that is chosen. The optical sensor will require a specific GPIO pin to supply a steady voltage between 2.2 and 3.6 volts also dependent on the specifications of the model chosen.

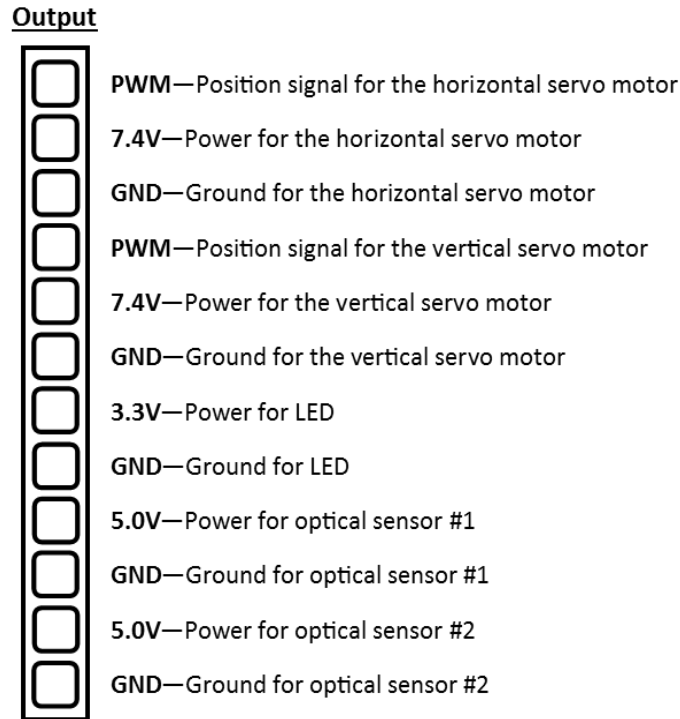

Figure 4-15 – General Purpose Output Pins

4.9.3 Microcontroller

4.9.3.1 Hardware

The microcontroller used in the project's system control board will be need to meet certain specifications in order to function properly in all aspects of the tasks it will be required to perform. Atmel was chosen as the manufacturer that will be used for the processor that will be used on the system control board. This manufacturer was chosen based upon its great reputation for a quality product and for the very extensive list of processing parts that they currently offer. In addition to the great hardware they also have their own development platform for their microcontrollers.

The Atmel microcontroller used will depend on the final design of the video subsystem. If the video subsystem uses a USB camera the microcontroller that will be chosen will be one of Atmel's AVR32 microcontrollers. If the final design of the video subsystem uses a Wi-Fi camera the microcontroller that will be chosen will be one of Atmel's AVR8 microcontrollers. The AVR line of products from Atmel focus on high performance and low power consumption. This is a great fit to meet the needs of the project. The high performance will be crucial to prevent any unnecessary latency or lag when the microcontroller is processing many tasks simultaneously such as controlling turret servo motors and firing the coil gun. The low power consumption will be beneficial as the board will already be supplying power to several modules such as the servo motors, Wi-Fi module, USB interface, and sensors. These high quality features come at a conveniently

low price. The AVR implements a modified version of the Harvard memory architecture which will allow for greater speed to be achieved. By having separate memories and buses for the code and the data a single clock cycle can be used to access code and data.

If the USB camera is used a 32-bit AVR by Atmel will be implemented. It uses reduced instruction set computing (RISC). This processor design strategy uses a simplified instruction set to achieve higher performance. This model also implements a peripheral direct memory access (PCDA) controller. This feature reduces the traffic and workload of the processor bypassing the processor's involvement and transferring data directly between peripherals and memory. The microcontroller will have the following specifications.

- Up to 15 general purpose 32-bit registers
- 66 MHz maximum operating frequency
- 100 pin count
- 128KB flash
- 32 KB SRAM
- 10/100 Ethernet MAC
- Full speed USB 2.0 with embedded host capability
- Consume 40 mA at 3.3 volts

If the Wi-Fi camera is used an 8-bit AVR will be implemented. It, like the AVR32s, uses RISC architecture. This model balances processing speed and consumption of power and attains 1 MIPS per MHz. It does this by instructions being executed in a single clock cycle. The microcontroller will have the following specifications.

- Up to 32 general purpose 8-bit registers
- 20 MIPS throughput at 20 MHz
- 32 GPIO lines
- 32KB flash
- 2KB SRAM
- Operates at 1.8 - 5.5 volts

4.9.3.2 Software

Atmel microcontroller based applications have the advantage of an environment provided by Atmel for programming the microcontroller in the project. The software suite is called Atmel Studio 6 and it is the integrated development platform (IDP) for Atmel products. It supports C and assembly for the writing, building, and debugging of code for the microcontroller. This software is downloadable from the Atmel website and is completely free of charge. The most recent version not in beta is Atmel Studio 6.1 update 2.0 (build 2730) and will be the version used for this project. It contains the version noted with Atmel Software Framework 3.11.0 and Atmel Toolchain. The Toolchain feature contains the tools and libraries collection that is used for creating AVR microcontroller applications. Also available from Atmel is a full user guide for the Atmel software

developer's kit.

The free open source code from Atmel Studio 6 will be used along with the library containing 1,600 sample projects for 8 and 32 bit AVR microcontrollers. They will be referenced when designing and writing the program that will be implemented in the microcontroller of the project. Referencing existing projects will save time by not having to write code for programs that have already been written and are available as open source code. Another aspect of Atmel Studio 6 that will save time is the in circuit debugging feature it has. This tool along with setting breakpoints allows you to get the following information: see all variables and their values, see all registers, monitor interrupts and their causes, and step through code one line at a time for error detection.

4.9.4 Power

The PCB will have power supplied to it from the power subsystem of the project. It will ensure that all of the parts being run off of the PCB will have the power they need to function properly. The Wi-Fi module, the USB interface, and the status LED will each have a supply of 3.3 volts and a ground. Each of the two servo motors for the turret subsystem will have a constant voltage of 7.4 volts applied as well as a ground line and a 5.0 volt line for the PWM. The optical sensors will have a constant voltage of 5.0 volts and ground as well. The microcontroller also uses 3.3 volts and a ground.

To interface the PCB to the power subsystem of the project a PCB vertical mount DC power jack will be used. As implied by the name, this jack will receive DC power from the power subsystem. It will be mounted directly to the PCB using through-hole mounts. It has an integrated on/off switch as a safety measure to make sure there will not be a surge when it is plugged in. The jack is female, has an inside contact diameter of 2 millimeters, and a center pin length of 4.4 millimeters. It has a DC voltage rating of 24 volts and a current rating of 5 amperes which allows for sufficient power to be drawn by PCB to run all of its components. This power jack design is used to allow for more versatility as opposed to a hard-wired design that is much more permanent. With the power jack the PCB can be more easily removed from the project for the purposes of making improvements and testing.

Regulators are a key component in the power system of the PCB. Multiple regulators will be implemented in order to produce the correct voltages to each of the modules and components that need it. 3.3 volt regulator models will be used to step down the voltage coming in to allow a safe level for operating several components. These components are the microcontroller, Wi-Fi module, USB interface, and status LED. 5.0 volt regulator models will be used to step down the voltage for use in PWM. The last model of regulator that is needed is the adjustable voltage regulator. This regulator will be used to adjust the voltage down to 7.4 volts for use in the operation of the servo motors. An adjustable

regulator is needed to account for the lack of a standard 7.4 volt regulator. An overview of the PCB power layout can be seen in Figure 4-16.

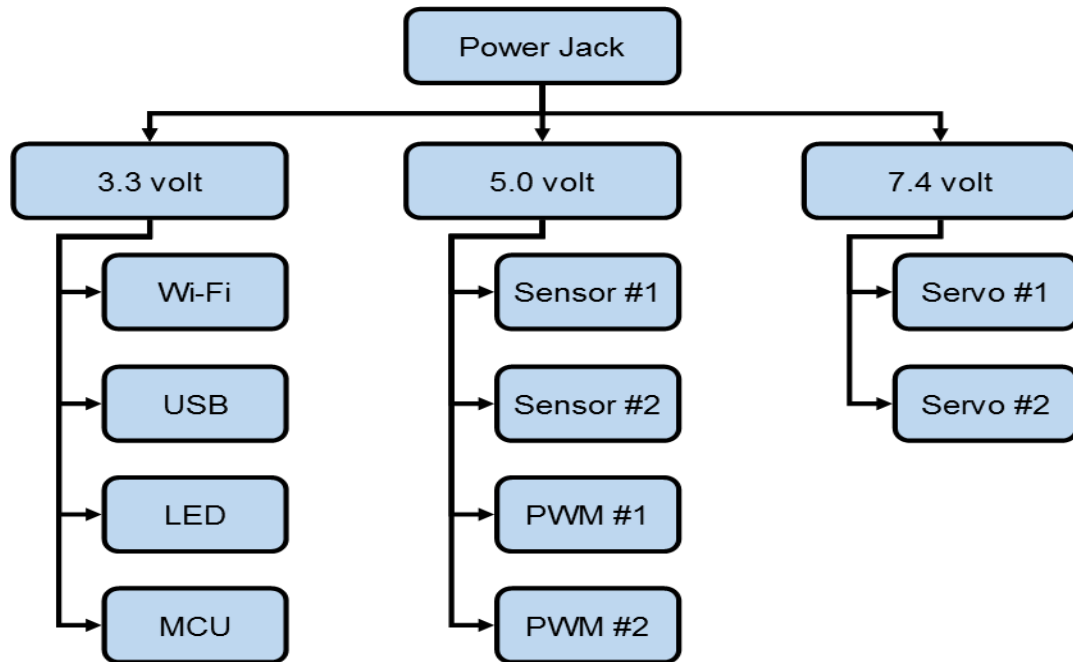

Figure 4-16 – PCB Power Layout Overview

4.10 Optics

The video subsystem is designed to meet the specific requirements of the project. The design prioritizes having a live and constant video stream over having a resource heavy, high resolution image. This prioritization was done because the project needed to be able to produce a real time video feed so the operator is aware of what is in front of the coil gun at all times. This is another safety measure in place to keep people safe. By scaling back the resolution of the image and the color depth of the image, the frame size is reduced and a faster frame rate can be achieved without requiring a larger bandwidth to accommodate for a change in bit rate. The calculations that follow were done to find the bit rate required for the system. Table 4-14 shows the variables with their description, value, and units that were used in the bit rate calculations. [29]

Description	Variable	Value	Units
Resolution	R	120x160	pixel
Color Depth	C	8	bit
Frame Rate	Fr	24	frames per second (fps)

Frame Size	F_s	$R \times C$	bit
Bit Rate	Br	$F_s \times Fr$	bits per second (bps)

Table 4-14 – Bit Rate Variables

$$\text{Frame Size: } F_s = (120 \times 160) \times 8 = 153.6 \text{ Kbits}$$

$$\text{Bit Rate: } Br = 153.6K \times 24 = 3.6864 \text{ Mbps}$$

4.11 Software Implementation

4.11.1 Software Block Diagram

The overall software class diagram with all of the individual functions is labeled below in Figure 4-17. This class diagram discusses all the features and its individual parts that will be discussed throughout the software implementation.

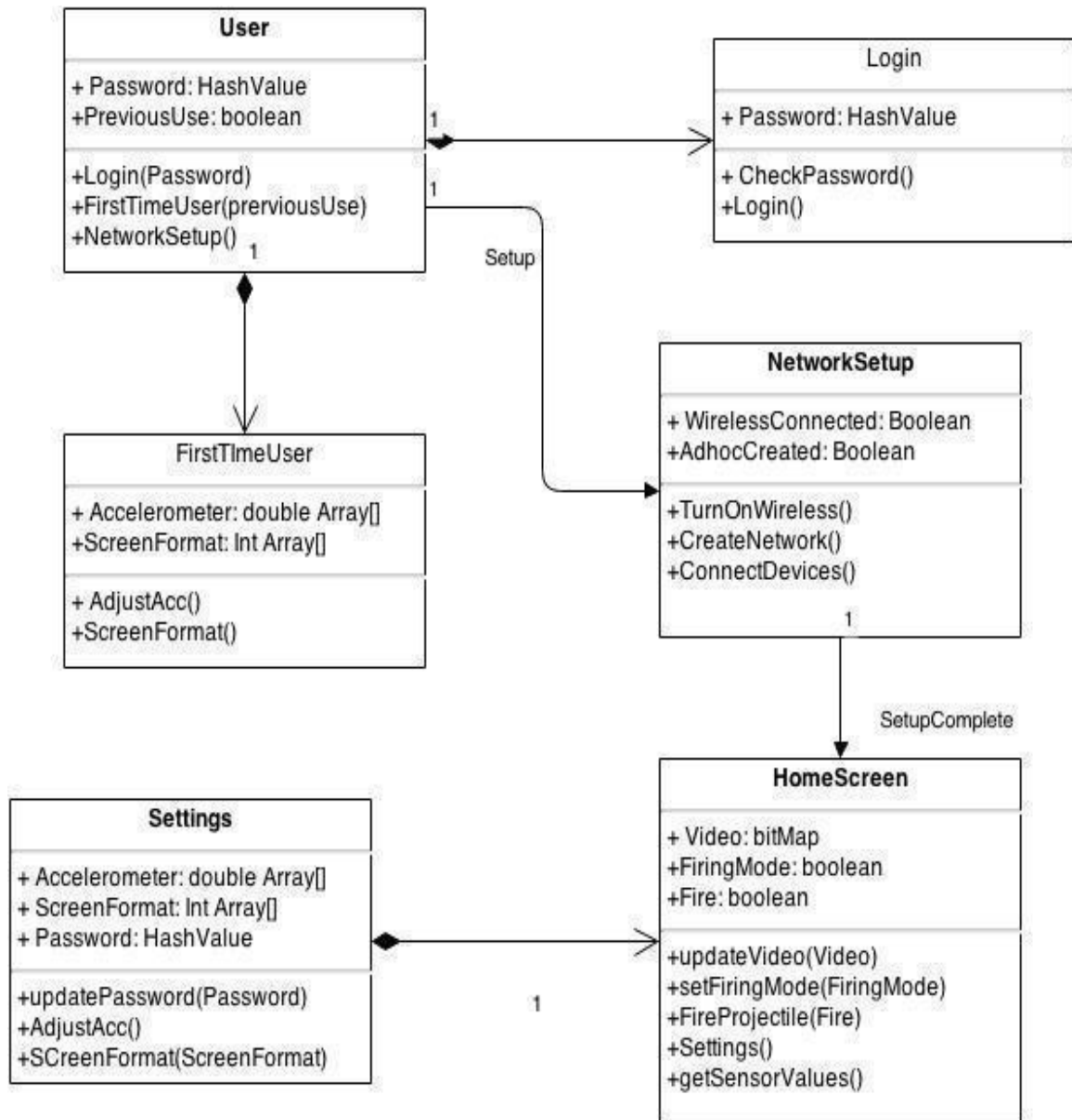

Figure 4-17 – Software Class Diagram

4.11.2 Android vs. IOS

During the implementation of the Automated Coil Gun, one of the factors needed to be decided on was the platform the application would run on. As both Android and IOS have their many advantages and disadvantages, this was an important issue that needed to be decided on. Both platforms have grown extraordinarily in the past few years, as have the information, processing power, and software development guides associated with them. There are many factors we considered before making our final decision. These decisions included cost, relevant programming languages, and difficulty.

One of the bigger decisions we made as a group was the cost of programming in each platform, which we originally thought would be free for both. This assumption turned out wrong, as programming in IOS costs ninety-nine dollars a year. Another hitch in programming in IOS is that this platform can only be programmed on a Mac computer. On the other hand, Android's software development kit (SDK) is completely free and the only cost comes if one decided to publish this application to the app store, which is irrelevant for our intended use. In comparison, the IOS cost to develop is nearly 100 dollars more than Android's.

The second issue needed to be discussed is the relevant programming languages. This issue discusses what programming languages are acceptable to program in on each platform. After doing some research it was discovered IOS is programmed in a language known as objective C, which is very similar to the original C programming language with an object oriented twist. The main difference between this language and regular C, is an added Smalltalk-style messaging, which adds more functionality for the user. The main programming language for Android development is Java, which is a well-known and widely used language for many types of applications. Due to familiarity, this language seemed to best suit the needs of the automated coil gun project.

Another matter that needed to be looked at is the sheer difficulty of each platform. As the group had never programmed for either of these platforms and were on a strict time schedule, this issue would play a big role in the decision-making. After comparing both platforms from other programmers' perspectives, it seemed, overall, that IOS had an easier platform to program on. The reasons for this come down to the building of the GUI interface, API, and amount of documentation. As IOS has a far more popular crowd of developers and users, previous users have made it much simpler to understand the ins and outs, and have developed tools to provide convenience for the developer. With all this being said, the group has a much larger background in java programming. This background would give a much bigger advantage in programming for Android, as it is most friendly to our needs.

With all options considered, the group made an ultimate decision to use Android as our platform of choice. Due to the reasons and research listed above, this platform seemed like the best fit in the development of the automated coil gun.

4.11.3 User Interface

Many of the elements of the coil gun are indifferent to the user, while playing an important part in the overall design. This is where the User Interface comes into play. The job of the UI is to take care of the backend information and give an easy to use control for the user. The backend information is discussed in section 2.3.4 of the software specifications.

The UI once started prompts the user to login using the password created by the group. This password is encrypted as discussed in section 4.13.4.2. Once the user gets passed this login screen they are displayed with a first time login screen in order to properly calibrate the device. This calibration includes proper screen formatting selection, and adjustment of the accelerometers. As these factors vary from device to device this is an important calibration that needs to be done for each first time user.

Once this calibration is done the next thing to do is ensure the user has a wireless connection and that their device is setup to create an ad hoc network. After this connection is made sure of the user will be taken through the steps of setting up the network for connection to the PCB and the wireless camera. This step will need to occur each time the application is started as this step is crucial to the entire application.

Once all the preliminary steps are taken care of the user is brought to the main screen of the application. This screen includes the camera feed, a button to fire the coil, settings, current sensor values and selection of the different firing modes. The camera feed will be displayed as the background of the main screen as the format of this feed will be quite large and important to see in detail. At the bottom section of this screen the different buttons will be displayed for the user to interact with.

The first button to be discussed is the firing button as this is the main purpose of the project. This button had a direct tie to the reading of the voltage sensor, as per the specifications of the project. The firing mechanism was not allowed to be activated until the required voltage was met. In order to adjust for this, until the application read a voltage of 480 volts the button was grayed out making it unusable. Once this voltage was acquired the button lit up red allowing the user to fire. As a safety feature of this button being pressed accidentally, this button was required to be held for 3 seconds with a countdown displaying on the screen. Once this countdown timer was reached the projectile was fired.

The settings button brought the user to a new screen with the different settings of the application. These settings included readjustment of the accelerometers, and changing of the launch password. The accelerometer's adjustment brought the user to the screen that was previously discussed. The changing of the password, much like other applications, prompted the user for the current password to avoid manipulation from an outside user.

To help the user better understand why restrictions or movements were being made the different sensor values are displayed on the main screen. These sensors are the three accelerometer values, and the voltage sensor. The displays of these different values were located in the top right corner of the application with their appropriate labels. These values had no user interaction and simply provided feedback.

The last part of the UI was to allow the user to adjust between the different firing modes. The Automated Coil Gun has the feature to fire in different modes including single fire and burst fire. To switch between these different modes a button was added. The application always starts in single fire mode and the button currently displays the fire mode it is in. Once the button is selected the firing mode is changed and the label is changed accordingly. Different capacitors were used for different modes so selecting a different firing mode changed the voltage meter. In order to stop the user from allowing the gun to fire by reading the wrong voltage, the firing button is automatically grayed out for 3 seconds while the new voltage is read.

Errors are bound to happen in large integrated projects such as this one. In order to adjust for these errors the UI needed to adapt accordingly. The errors that brought up the biggest concerns in terms of the UI were voltage sensor readings, video feed, and network connections. All three of these concerns had application breaking potential and needed to be checked for. The fixing of these concerns allowed for the application to display these errors instead of completely crashing.

The first error in which the voltage sensor not receiving a reading would not allow the gun to be fired at all or even worse fired when not supposed to. In order to adjust for this first the connection to the PCB was checked to make sure that functionality between the two exist. If this was working properly this narrowed down the error to the voltage sensor itself, but in either case the user was notified of the specific error and closed the application.

As discussed previously the camera feed had many different requirements in order for it to work. These requirements if not met would not allow display of this feed. As video feed is very complex especially being received as a live feed from a wireless source certain complications are bound to happen. In order to adjust for this instead of completely closing the application the background of the application simply displayed "No video to be displayed". This helped the user fix this problem without crashing every time a small shortage in video feed wasn't received.

The last issue was complete loss of connection and in its worst case would crash everything as the entire devices communication system was based on this connection. In the event of this connection failure there was no way for the device to adjust for this so the user was notified of loss of connection and the application closed.

4.11.4 Wi-Fi P2P Communication

In order for the microcontroller and the Android Touchscreen device to communicate with each other with reliable speed, Wi-Fi communication was chosen. The reason for this choice comes from its high speed data transfer, and that it is built into all Android devices running Android 4.0 software and beyond.

Wi-Fi direct or Wi-Fi peer to peer communication (ad-hoc) makes it possible for data to be transferred over devices built in Wi-Fi antenna with no need for a wireless access point. This is important in the development of the automated coil gun, as it can't rely on a wireless access point to be within the testing range at all times.

There are a few complications that can arise in an ad-hoc network that include security and speed. With a network like ad-hoc, security becomes an issue as it is not monitored by a third party device. This, in turn, can allow for unwanted connections with unwanted results. This is why the automatic coil gun needed to be equipped with password protection, to avoid this unwanted response. The second complication that arose was the unstable speed of this type of network. This speed drops from 54mbps to 11mbps due to its lack of structure in the connections initial "handshake". As a measure to fight this unwarranted behavior, the automated coil gun's video feed's quality was reduced in order to provide uninterrupted feed.

With Android's latest features, some Wi-Fi peer to peer networks can be implemented in as little as three or four steps. These steps are as simple as turning on Wi-Fi on both devices to be connected, activating Android's built in Wi-Fi direct connection, and then selecting the devices one would like to connect to. This design is great for its simplicity, but falls short in the design of the automated coil gun. The reasons for these shortcomings are the microcontrollers' weak processing power and the complex communication needed between the two devices this turret uses. Instead of using this nicely built-in feature, custom software will need to be designed.

With the huge influx of Android application development, it has become increasingly easier to implement these, once complex, features with a few built in functions. These functions play a few roles in increasing simplicity. The functions include a method that allows one device to discover and request a connection between local peers, action listeners to see when and what data is being sent and received, and disconnection of a peer. All of these actions are implemented through the WiFiP2PManager class. For the needs of the automated coil gun, the application will implement all of these features, with the added security of a password protected firing mechanism.

The exact method of establishing this connection was done executing the following commands: First, you must initialize your application for peer to peer connections by calling the initialize () function. Next, you must discover nearby devices by calling discoverPeers(). Finally, you must start the connection by calling connect(). Once established, a listener was called and took care of receiving video feed remotely.

4.11.4.1 Camera Feed

One of the big features of the automated coil gun is live video feed from a wireless camera. The first part of this is to establish a connection to the wireless camera, which was done in part 4.13.4 using Android's built in functions. The

next step is to establish the IP address of the wireless camera. This can be done by looking in the manual to see that it is located at the IP address XXX.XXX.XXX.XXX. The greatest feature of a wireless camera is that the video feed is automatically uploaded to this address as long as some sort of internet connection has been made. This feature eliminates the need to process the video feed through the PCB, which saves processing power and time.

One of the more limiting factors of the IP camera is the requirement of an internet connection. Without this connection, the video feed is unusable, as it is never redirected to the proper location. Without the upload to this location, no video will be received, which causes the control app to malfunction as it has nothing to display. One of the best ways to adjust this problem is discussed in section 4.13.4 when talking about an Ad-Hoc network. The idea behind this network is to use the Android's built in mobile network connection to create a mock router for the IP camera to connect to. Once this connection is made, an outside internet connection is no longer needed and everything can function as needed.

The output of the camera feed will be displayed much like Figure 4-18 below. The next step is to retrieve just the video itself in its specific video format that can still be displayed by the control app. This video format is important as the Android interface has a limited amount of video formats it can display. This is another reason the group decided to pick the camera that they did, as many cameras have different formats and this one fit their needs. Once the video was retrieved, the next step was to do some formatting to the video in order for it to be the proper size and video quality to display. Once all these settings are established, the video feed can be pushed to the control APP, giving the user the view of the live feed being displayed from the camera in real time.

The next task to be handled involved error handling in the form of frames being dropped. As this was a live video feed, much like communication through Skype or a phone call, if packets failed to arrive on time to display these frames, the video would be interrupted. The solution to this is to drop the frames using a protocol known as UDP, which drops frames if not received in the correct order to avoid non synchronous flow at the cost of choppy video feed. This would be less than ideal in situations where the data being transmitted was needed in its entirety. However, since this was not a needed function of this camera, this would have no effect on the overall specifications.



Figure 4-18 – IP Camera Feed
(Awaiting Permission from Francis D'sa to reprint)

The last task that was handled was complete loss of connection. If this error is to be left unhandled, the entire control application could crash due to passing null or empty variables into a function that requires a value. The way to correct this is to check this variable before trying to use it, and the nice thing about java programming is the built in ability of error handling. This error handling is known as a try-catch statement. This statement handles this failed reception and instead of crashing the entire application, it displays the error and continues to run the rest of the application.

Once all of these factors are taken care of, the camera feed can be directly injected into the application. The way to inject this video into the actual application is to use an Android object known as VideoView, which extends SurfaceView. The great thing about this object is it can receive video from multiple sources, and takes care of the measurements based on the user's needs. Another great feature of this object is the ability to scale to all different Android platforms. This object has the built in functionality to determine the device it is running on and to adjust the video's different parameters to fit onto this user's platform. This built in object has many built in features to take care of some of the overly complex functions that, if were needed to be built, would be overwhelming and time consuming.

4.11.4.2 Password Protected Launch

The application being built to control the automated coil gun is wireless, and high powered. With this combination comes the security risk of unwanted remote access, and firing of this lethal gun. This security issues has a very minimal chance of happening, but with the lethal potential of a coil gun it was in the best interest of the group to address. The solution that was chosen was to add a password protected launch at the beginning of the application. This mechanism would not limit the functionality of the coil gun in anyway but simply provide an extra measure of security.

This password protected launch would simply prompt the user for a password at the beginning of every launch. To avoid backdoors into the system such as launching an object in the code that started the application while avoiding the login screen, sessions were used. Sessions allowed the code to store the input the user used at the login screen, and if at any point this password did not match the required one the user would be backed out immediately.

The next backdoor to avoid was stealing of the password by simply decompiling the code and reading the password directly. The way to avoid this was to implement the password using password hashing. The idea behind this is to not store the password as plain text but to instead store the user's password as the value that's created when running it through the hash function. The reason this is secure is even if this hash value is stolen from the database it will provide no benefit to the potential hacker. As this hash value is still required to be passed into the hash function during login which would then completely change this value giving an improper login. This type of password protection is implemented by many of the higher level computer companies because if implemented correctly it is virtually impossible to break into the system.

Another added benefit of this hashing was the ability to change passwords without adding any further complications. The program is able to generate these hash values in constant time in terms of big O notation. This generation speed makes it so no extra strain is made on the processor when a new password is created as the only thing needed to be updated is the password storage located on the database.

In order to make sure the user could not simply edit the database on their device the database was stored on the PCB itself. Since the storage of only one password was needed this amount of data was minimal in terms of storage size. This minimal storage size and control over the PCBs physical security theoretically made the project completely secure from outside threats. This allowed for our application to be put in the Google Play Store or online for others to download without the added threat of being hacked. This benefited the group as if a new phone needed the application or it just needed to be reinstalled it could be done from anywhere securely.

4.12 Capacitor Charge and Discharge

The aluminum electrolytic capacitor will be the chosen type of capacitor for this application since it contains max voltage ratings and capacitance values within the ranges required for the coil. In addition, many aluminum electrolytic capacitors have screw tops, which will be useful for easy assembly when using a copper bus to connect the capacitors in parallel in the capacitor bank. Affordable capacitors in the range of \$12 per capacitor were found online through distributors' websites and online auctions sites. The chosen capacitors had a voltage rating of 450 volts and a capacitance of 1800 microfarads. While the voltage rating is within the desired range, the capacitance is slightly lower than wanted. In addition, the tolerance is 20%, which is higher than what would be ideal for this application, though high precision capacitors are not required. A simple solution is to add more capacitors to the capacitor bank to make up for this shortfall. Adding more capacitors will make up for any variance in the energy supplied as well as any variance due to tolerance. The capacitor chosen are shown in Figure 4-19.



Figure 4-19 – Capacitors Chosen for the Capacitor Bank

The capacitors in this project need to be charged and discharged effectively in order to provide the needed coil current. An important consideration is the capacitor charge and discharge time. The first consideration will be the charge time. The capacitor charge time depends on the capacitance, resistance, start voltage, and end voltage (what the desired charge voltage is).

The charging specifications for these capacitors will be a starting voltage of zero volts and end voltage of 350 volts and will be charged through a RC circuit. The supply voltage (from the power supply) will be 480 volts. The resistance will be assumed to be 1000 ohms and the desired charge time will be assumed to be

three seconds. For these parameters, a simulation of the charge time is shown in Figure 4-20. The peak power in the resistor for these specifications will be 230.4 watts and the peak current will be 480 milliamperes.

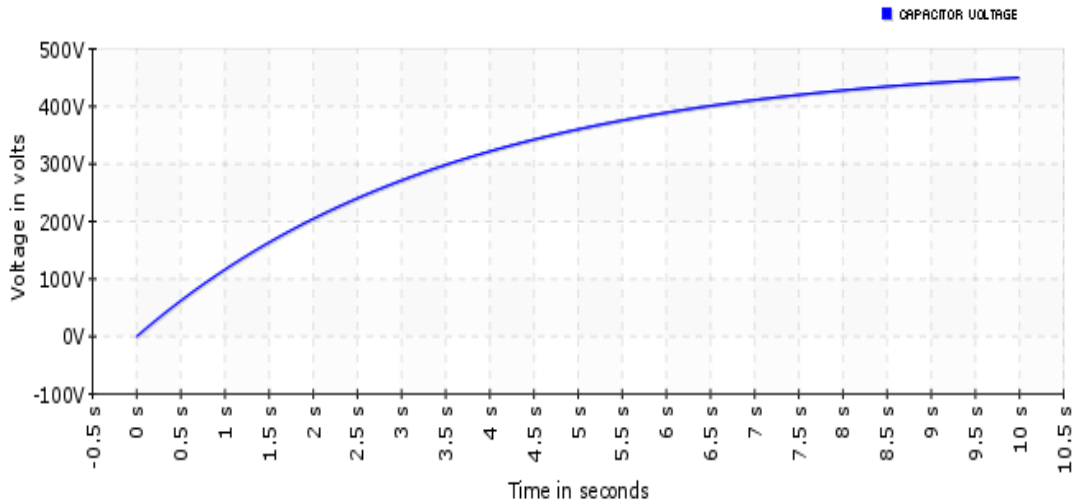

Figure 4-20 – Two 1800 microfarad Capacitors Charge Voltage vs Time with 480 Volt Supply Voltage

These specifications can be changed depending on the testing in the circuit. The charge time can change depending on the resistance and capacitance, though it is desired to have a fast charge time. Three seconds should allow a quick charge rate that is accomplishable. Expecting a charge time of milliseconds is unrealistic considering the power supply. A much faster energy transfer rate that would charge in the order of milliseconds should not be expected. The charge time will be tested in order to know what is expected for the different firing modes.

The discharge time of the capacitors can also be simulated however the discharge of the actual capacitors will be through an RLC circuit, not an RC circuit. The discharge time for the coil circuit can be found in Table 4-2. The discharge time of two capacitors, summing to 3600 microfarads, a start voltage of 350 volts, a resistance of 1000 ohms, and an end voltage of zero volts can be found in Figure 4-21. The peak power in the resistor is 122.5 watts and the peak current is approximately 350 milliamperes. This simulation can be used as a model in order to test the capacitors. The capacitors need to be tested and discharged and using an RC circuit will represent a practical testing circuit. Details of the capacitor testing procedure are found in Section 7.1.6. [30]

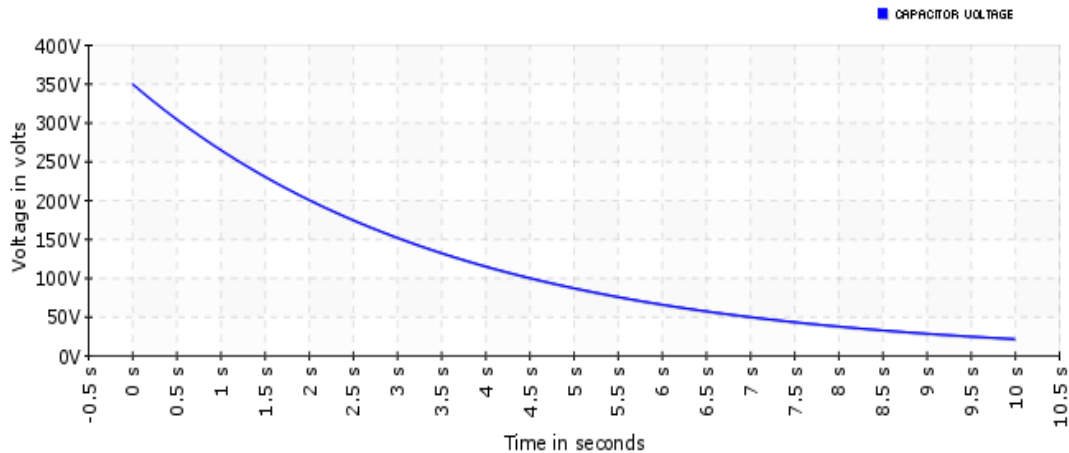

Figure 4-21 – Discharge Time of Two 1800 microfarad Capacitors Through an RC Circuit

4.12.1 Mode 1 (Single fire mode)

The typical way to charge and discharge capacitors for a coil gun are all at once. Each capacitor, being connected in parallel, is charged to the same voltage, which as mentioned before, is at some specified voltage. For safety reasons, the voltage is just below each capacitors maximum voltage rating. Here, the first charge mode will be implementing this same method. Each capacitor will be charged to a range between 300 and 400 volts. Each capacitor bank will then discharge in order to deliver the energy to the coil. This will allow the projectile to launch at its fastest speed while using two capacitors. Since two capacitors will be used, the maximum energy can be found using the equation 4-9 for potential energy. Using the equation 4-8 for kinetic energy, the projectile velocity can be found using the same method in the magnetic field Section 4.3.

The charging circuit for this first firing mode will be simple. The capacitor bank will be charged by simply connecting the rectified AC source (which is 480 volts DC) to the capacitor bank until they are fully charged. There will be a voltage display mounted to the turret in order to show what voltage the capacitors are charged to. In addition, the microcontroller will be able to read the voltage of the capacitors and determine that the desired voltage (around 300-400 volts) has been met. If so, a green LED will display on both the turret and the mobile application to verify the coil gun is ready to fire.

In order for the capacitor bank to be discharged effectively, there needs to a switching circuit. A diagram of what the basic circuit is shown in Figure 4-22. This circuit will be part of a printed circuit board that will be designed to handle the high voltage applications of this project. The switching circuit will allow the energy the flow from the capacitors to the coil effectively. The practical device to use for this is a silicon controlled rectifier (SCR). A SCR is similar to a Shockley diode except for the addition of one wire to the PNP structure. The applications of a

Shockley diode is limited, however with the addition of the third wire to the PNP junction, thus creating the SCR, the usefulness of the device can be extended. A useful application of SCRs are switching circuits. This is because a relatively small amount of current applied between the gate and cathode can allow a large current flow through the second transistor. This provides a small amplification effect and is ideal for controlling larger current flows with a small amount of current. This is practical since the control for releasing or handling larger currents is almost always low current (since, for example, a small voltage control signal will be sent from a microcontroller).

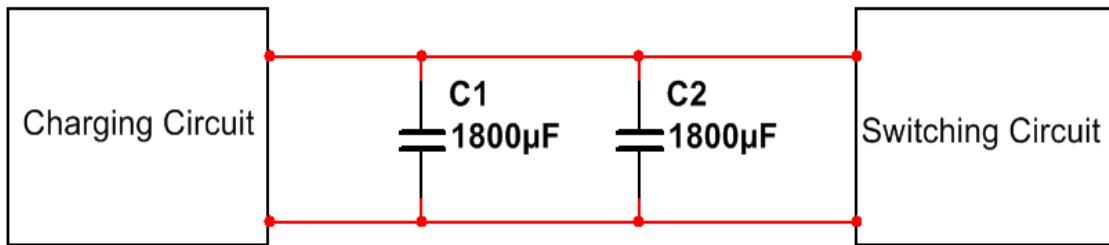

Figure 4-22 – Basic Diagram of Charge and Discharge Circuit

The design of a SCR switching circuit will to handle the current flow of the entire capacitor bank will need to be handled carefully. First, the switching circuit will need to be able to handle the current flow of the entire switching circuit. Since two capacitors will be used, the max current flow can be calculated using equation 4-10. Therefore, the current and voltage rating of the SCR need to be at least 350 amps. The switching circuit will be found in Figure 7-2 in section 7.1.1. [31]

4.12.2 Mode 2 (Semi-automatic mode)

A difference between this coil gun and others will be the way the capacitors are charged and discharged. This second mode will allow the capacitors to be charged at a constant rate, until they have reached the specified voltage. The difference here is that the capacitor bank will be split into smaller capacitor banks consisting of one capacitor each. This will allow each smaller bank to be charged and discharged separately. In order to accomplish this, the three capacitor banks will need to be charged separately. Though this complicates the design, this method will allow each capacitor bank to be charged separately, allowing a semi-automatic firing mode. With this design, each capacitor bank will be charged immediately after it is discharged in order to reduce charging time and eliminate the need to stop firing in order to charge.

In order to accomplish this design, three separate SCRs will need to be used for the switching circuit. A basic diagram of this configuration is shown in Figure 4-23. Since the current released from the smaller capacitor banks will be lower, the SCRs and appropriate section of the switching circuit will not need to handle as

much current. This means the max SCR ratings can be smaller, which should be cheaper. Usually devices with larger max ratings are more expensive. This design means that four total SCRs will be required. One SCR that has higher max ratings for the single fire mode and three SCRs that have smaller max ratings for the semi-automatic fire mode. The design of the switching circuit itself can be done on one printable circuit board (PCB). Therefore, the design can be more compact and economical. The downside is that more components are required for this mode. The need for multiple SCRs to allow the switching to work properly adds more parts and therefore space and cost. However, the design is for a turret, not a handheld weapon therefore the design does not need to be compact. The lower ratings on the SCRs should mean that this will lower the additional cost since they should be cheaper.

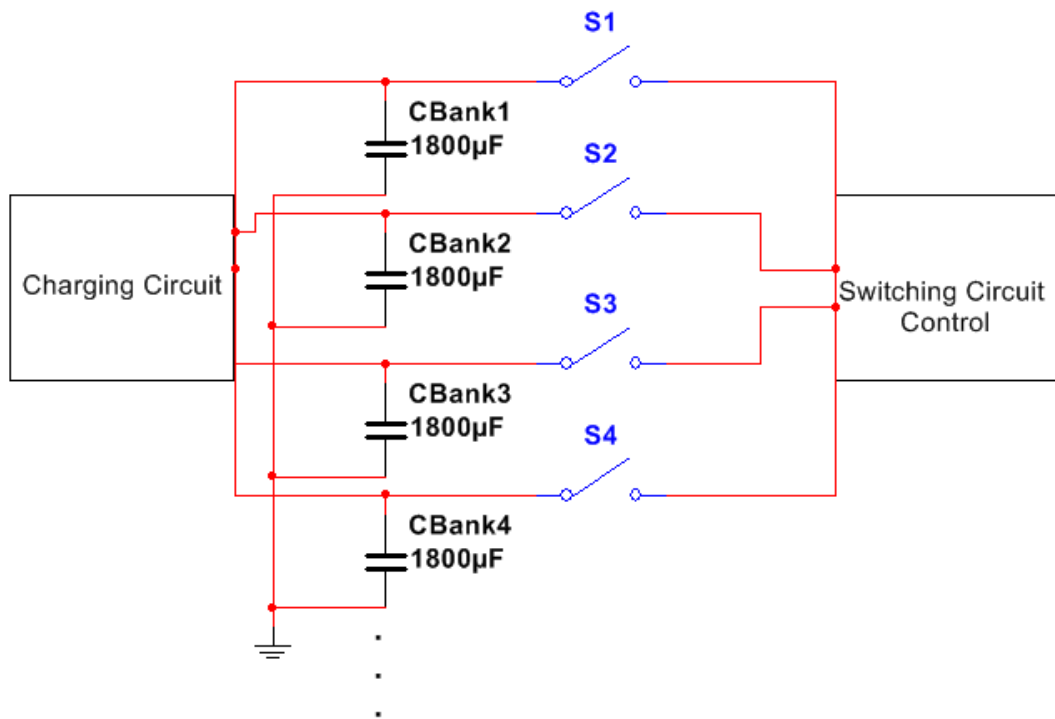

Figure 4-23 – Basic Circuit Design for Semi-automatic Firing Mode

4.12.3 Mode 3 (Burst mode)

The third firing mode to be implemented will be a “burst” mode. The setup will be the same as the second firing mode i.e. the capacitor bank will be split into three separate smaller capacitor banks. Here, the smaller banks will be charged in succession, that is, once one bank fires, it will be charged immediately afterward, just as in the second firing mode. This will allow for faster response time between firing. This firing mode will implement the same setup as in firing mode two (refer to Figure 4-23).

Here, the three separate capacitor banks will be discharged within 10

milliseconds of each other, requiring timing control from the microcontroller. This will allow the “burst” firing mode, which will shoot three projectile in succession. The capacitors will then charge until the desired value and the coil will be ready to fire again. The basic circuit of this firing mode with the timing control is shown in Figure 4-24.

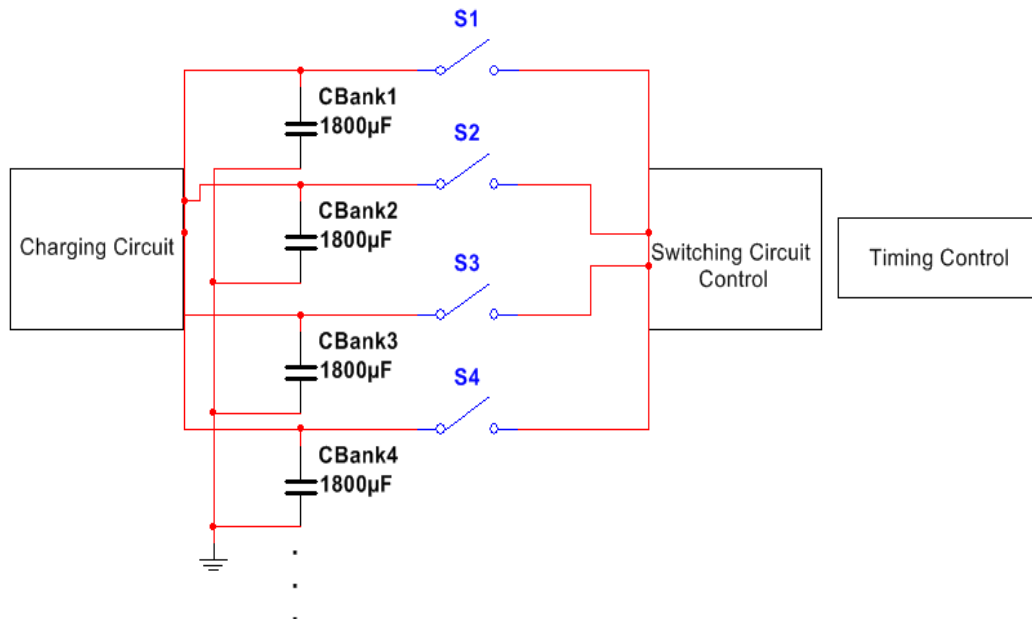

Figure 4-24 – Basic Circuit Design for Burst Firing Mode

For this firing mode, the use of a battery has an advantage over the use of capacitors for energy storage devices. This is because the use of a battery eliminates the need to charging and discharging, i.e. the battery has power that is always there (at least until the battery is drained and does need to be recharged). The details of the advantage and disadvantage of using batteries is explained further in Section 3.11.1.1.

The SCR (or thyristor) that could be used for this project is the 500 volts, 20 amp rated thyristor from Mouser. This device is used for car starting applications, which requires large boosts of current from the battery to the starter. This would be ideal for this scenario since the coil deals with this exact scenario.

4.13 Power Supply

A power supply is an important part of any electrical device. Controlling a steady and stable power source is crucial for all electrical components. Often, this involves converting a 120 volt, 60 Hz, alternating current power source to a low voltage, direct current source to power many microelectronics other electronics. Different considerations can be addressed when designing the power supply, mainly, power from a wall outlet or from batteries.

4.13.1 Energy Source

4.13.1.1 Batteries

If batteries are considered for the project, the first step is to know what power requirements are needed. The power requirements for the coil can be calculated from requirements in Section 4.3 in Table 4.2. Using equation 4-26 below, and the energy, distance, and mass of the projectile (assuming eight projectiles in the clip), the power requirement is calculated to be approximately 460 watts.

$$\text{Power (P)} = \frac{E^2}{d \cdot \sqrt{2m}} \quad (4-26)$$

Batteries that would be considered would lie in the range of 2500 to 5000 mAh. These are usually Lithium ion or Lithium polymer batteries. These type of batteries are commonly found in hobby “toys” such as RC cars, helicopters, planes, etc. A battery that could be considered is one from Racer’s Edge that is 5000 mAh, 20 C, and 7.4 volts. This battery is lightweight, weighing only 264 grams which is a little over half a pound. The cost through an online retailer is approximately \$55. Using multiple batteries would allow stronger currents and more discharges, however this would make the design more expensive. This specific battery contains Deans plugs and is shown in Figure 4-25. [5]



Figure 4-25 – Racers Edge Brand 5000 mAh Battery

4.13.1.2 Wall outlet

The other energy source for this project is a wall outlet. The advantage of using a wall outlet (which in the United States is a 120 volt, 60 Hz AC signal) is that higher power is obtainable. Starting off with 120 volts, assuming capacitors are used, makes it easier to obtain the 450 volts the capacitors will be charged with. The voltage will simply need to be stepped up and rectified, the process of which is explained in Section 3.11.1.1. The ability to obtain 450 volts from the capacitor bank means more current can be obtained with the tradeoff of a longer charge time. However, while capacitors need to be charged and discharged, they can do

this process repeatedly as long as heat constraints allow it. The charge and discharge process does not need to be stopped as it does with the batteries in order to recharge. The use of a battery is more common for a rapid fire coil gun because of the disadvantage of the capacitor charge and discharge time. The time constant needs to be considered since it can be significant. The capacitor charge time to reach 350 volts, which is found in Section 4-12 using the two capacitor was found to be approximately five seconds.

With these options available, the decision was made to use a wall outlet as the energy source and capacitors as the storage device. While this is a coil gun with different firing modes, of which one is rapid fire, the steady alternating current supply was still chosen. While the use of batteries seems to have an advantage when designing a rapid firing mode, the steady and readily available power from the wall outlet seems to be the better option to power both the coil and the microcontroller components. The decision to split the capacitor bank into smaller capacitor banks, found in Section 4-12, should allow the coil gun to fire rapidly and maintain high firing speeds since the capacitors allow higher current bursts. Experimental methods and circuits for this design can be found in prototype testing in Section 7.0.

4.13.2 Turret Power

The power requirement for the turret is relatively low. The turret itself is controlled by two servo motors that will control the movement. The required voltage to power the turret servo motors is 7.4 volts. The servo motor for the turret will not need a separate power line because it will be powered by GPIO line from the microcontroller. This will make the control easier since the interface between the motor controls will be directly connected to the microcontroller. The details are discussed in Section 4.8. The control of the servo motor will be the only power needed for the turret, which will be provided through the microcontroller.

4.13.3 Control Power

The power requirement for the controller is low. A microcontroller will be used in order to control the camera, logic, switching, voltage readout, Wi-Fi, and controller, and other components. The low voltage from the wall outlet will be separated, rectified, stepped down, and regulated in order to provide the required nine volts for the microcontroller. The schematic of this circuit is shown in Section 3.11.1. There will be a protection circuit and a switch from the supply power to the microcontroller in order to prevent and damage and turn off the microcontroller supply power if necessary. The protection circuit can be modeled in a breadboard and will be designed and tested. The plans for this testing circuit can be found in Section 7.0. Refer to Section 6.2.1 for how the breadboard will be constructed and laid out.

4.13.4 Coil Power

The power needed for the coil is high. The coil current needs to be high in order to launch the projectile at the required speed. Since the power source is provided from a wall outlet, the voltage needs to be stepped up, converted to direct current, and regulated in order to charge the capacitor bank. This requires separation from the low voltage circuit and additional protection for the high voltage end. The power to the coil will have a protection circuit and switch in order to provide protection and control over the high voltage. The protection circuit for this can be found in Section 4.11.6 and the circuit for the high voltage charging and discharging circuit can be found in Section 4.12.

4.13.5 Circuit Protection

Circuit protection is important for any electrical circuit. A circuit needs to have protection from too much voltage or current on components in order to prevent damage or circuit malfunctions that could lead to further damage. In some lower power circuits that are powered by low power energy sources, such as batteries or solar panels, circuit protection may not be as important. However, when dealing with large power sources that are powering both high and low power components, circuit protection is very important.

A very common method of implementing basic circuit protection is using switches. This is true many household and industrial machinery tools; a switch is required to turn on the power to either the entire device or a subsection of that device. Multiple switches will be used for this coil gun to ensure a basic level of circuit protection. The first switch will be between the power source (the outlet) and the transformer and protection circuits. This will be the “main” power switch for the coil gun. Another switch will be used between the high voltage protection circuit and charging circuit. This is to ensure total control over the high voltage and that the charging circuit is only active when chosen to be. Control over high voltage is very important. The last switch will be between the “step down” circuit, i.e. the power supply to the microcontroller. The protection for the microcontroller is also crucial. Too little power can cause the controller to power off and could cause malfunctions of the coil gun. Too much power can cause the board to be damaged and again malfunction or not work at all. The low power circuit protection will take care of this issue, however a switch will still be added just in case some diagnostics of the camera, fan, or other components that are controlled by the microcontroller need to be tested.

The other method that will be used to protect the circuit components is a protection circuit. These usually consist of diodes in order to prevent any current from flowing in the wrong direction. The protection circuit also usually have capacitors in order to absorb small amounts of voltage that may fluctuate from

the desired voltage. These capacitors are normally placed in low or high pass filters to filter out any disturbances.

4.13.6 User Safety

All ethical engineers hold safety as the highest priority in any design. The IEEE code of ethics holds safety as its highest priority as is stated from the first code that mandates “to accept responsibility in making decisions consistent with the safety, health, and welfare of the public, and to disclose promptly factors that might endanger the public or the environment.”[32] Any application or device that uses high voltages or currents requires a high level of safety. Therefore, it is both ethical and the responsibility of the engineer to design devices that will not endanger the user or the public, even if this means the device has a greater economic cost. With this in mind, safety will be designed into every step of this project to ensure no one is harmed.

First, the coil gun will be used responsibly and be targeted only at inanimate objects. No person will be targeted or fired at in any scenario. The projectiles fired are made of iron and travel at high speeds which can cause great harm, therefore care should be taken to make sure no person is within the scope and range of the projectile's path. Since only a camera will be mounted to the barrel in order to provide visual feed for the user, no mechanism will be in place to recognize a person or animal is within the sights of the coil gun besides the user, therefore care will need to be taken to make sure the projectile's path is clear and all are out of harm's way. In addition, since the projectiles will be fired at a high speed and crashing into a targeted area or object, it is possible shrapnel will result from the collision. This means someone standing even close to the targeted area or object can be harmed. It is of the highest priority and importance that the entire area of the projectile's path and target be cleared in order to minimize any possible danger of harm from the demonstration.

Second, since this device uses power that is provided from a wall outlet, care should be taken in the design of the power supply to make sure no harm comes to anyone from electric shock. Within the power supply, protective circuit elements (i.e. diodes) have been put in place to prevent back current. While this protects the circuit elements and the microcontroller from damage, this serves two purposes because damage to a device that handles high currents in the range of this device can be dangerous to anyone near it. The coil gun will be contained within a case that should prevent any electric shock that may occur if someone touches the wrong area, however this shouldn't be a problem since there won't be any exposed circuitry.

Another issue to consider is the capacitors being charged with the wrong polarity, which can cause them to be damaged or explode. Capacitors in the range of one to ten microfarads that explode do not cause too much harm, however capacitors in the range of 1000 to 3000 microfarads, which are the size of soda cans or larger, can cause great harm if they explode. Care should especially be taken to

ensure they are not charged with reversed polarity. In addition, discharging capacitors of this size can be dangerous. Transferring the large amounts of energy stored in the capacitor bank leads to high voltages and currents. Dissipating this through a small under-rated resistor can cause the resistor to flash and burn up. A wire that is too thin can melt if it cannot handle the current passing through it. Therefore, it should be noted that voltage and current ratings (i.e. power ratings) of all components should be adhered to in order to not damage the parts and maximize safety.

To summarize, safety is very important to adhere to in this project. Projectiles being fired causes the need for extreme caution in operation. High voltage and currents requires an extra need for safety to prevent shock or electrocution. While demonstration of the resulting product is the ultimate goal, the project would be wasteful if it cannot be shown be operated in a safe manner. Therefore, the standards and rules specified in this section should always be followed.

5.0 Design Summary

5.1 Final Gun Design

The final design of the coil gun prototype is based on the research, calculations and simulations performed and explained in this report. The prototype of the gun design will consist of components including the projectile, barrel, coil, loading mechanism, housing and velocity detection. At this time the prototype will not include any components for the cooling of the coil, this aspect of the project will be examined during the bench testing of the gun and can be added easily to the design if necessary.

The projectile that was chosen for the project is an 8 millimeter steel rod. This was chosen because the steel is a material with a permeability that should allow magnetization necessary to be accelerated by the field. The steel rod is also inexpensive and readily available, it can be found at home improvement store like Home Depot or Lowes and is available in 1 or 3 foot lengths that allow for easy fabrication and customization of the projectile length that results in maximum muzzle velocity.

The barrel chosen for the coil gun is a ¼ inch schedule 40 PVC tubing. The tubing was chosen due to the inner diameter of around 9 millimeters that allows the projectile to slide easily down the barrel while keeping the air gap at a minimum. The PVC also means not having to modify the barrel to eliminate eddy currents and the wall thickness keeps the air gap at a minimum while still providing the physical strength needed. The barrel will be housed in a square tube constructed with 0.093 inch acrylic sheets that can also be found at any home improvement store. The gun housing gives additional strength to the gun and a surface for mounting the optical sensors, camera and other components needed to operate the coil gun. The placement of the projectile magazine will be chosen by determining experimentally the starting position in which the projectile exhibits the greatest muzzle velocity. The magazine will be constructed of the same acrylic sheets as the gun housing and placed on top of the barrel to allow the projectile to drop into place. The projectile will be held in place using a 5/16 inch bolt installed in the end of the barrel with a magnet attached to the bolt's head.

The prototype for the coil will be made using #14 AWG magnet wire. The wire is Essex brand with an insulation rating of 200 °C and an insulation consisting of a Base Coat of Modified Polyester Resin and an Overcoat of Modified Amide Imide Resin. Using the Matlab function for calculating the inductance of the coil and the Inductor Simulator from www.coilgun.info the coil dimensions were finalized as 14 millimeters inside diameter, 42 millimeters outside diameter and 52 millimeters for the coil length. Using these parameters the length of the wire was

determined to be between 21 and 22 meters, which was used to determine how much wire is needed to be purchased to be able to fabricate up to 3 coils in case some are damaged during testing or operation of the coil gun.

The velocity of the projectile will be determined using the optical sensor circuit designed in section 4.7. The IR LEDs were chosen as not to allow the sensors to be triggered by visible light. The IR LED and IR phototransistor chosen are manufactured by Honeywell with part numbers SE3455-003 and SD3410-002 respectfully. The IR LED outputs gallium arsenide with a 935 nanometer wavelength and an optional beam angle of 90 or 20 degrees. The IR sensor is an NPN silicon photodarlington that is mechanically and spectrally match to the IR LED chosen. The sensor has an optional acceptance beam angle of 90 or 12 degrees. The output of the LM393 comparator will be used to for the signal to start and stop the timer of the microprocessor. [1]

5.2 Final PCB Microcontroller Design

The final design of the PCB microcontroller is constructed from the research and calculations done throughout this report. The final design was decided upon in order to meet the specific requirements of the system control board for the automated turret project. The final system control board will consist of the PCB, microcontroller, USB interface, Wi-Fi module, GPIO pins, power jack, voltage regulators, resistors, and capacitors.

5.2.1 Schematic and PCB Layout

The PCB itself will be designed using a Cadsoft product called Eagle. It is a PCB design software consisting of two major components, a schematic editor and a layout editor. The schematic editor will be used first to set up to represent the design of the circuits that interface the various components on the board with all of the electronic components (capacitors, resistors, etc.) represented on this diagram as well. After the schematic design is finished the components chosen can be exported to the layout editor. In this editor the virtual representation of the physical parts are placed and positioned on the virtual representation of the physical board. The physical layout of the components on the board will be organized to allow easy access to the peripheral interfaces such as the GPIO pins and USB port. The screenshot in Figure 5-1 shows part of the schematic editor in Eagle for the Arduino Uno. The screenshot in Figure 5-2 shows the layout editor in Eagle for the Arduino Uno. These files are provided in Eagle as examples that can be referenced when designing a PCB. The design of the PCB for this project will be modeled similar to the Arduino Uno and these files will be referenced for the design.

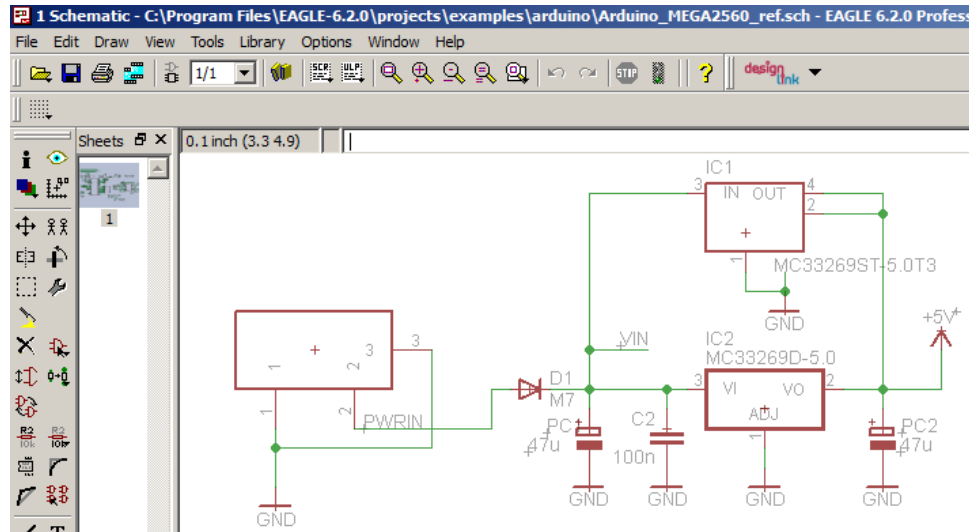

Figure 5-1 – Screenshot of Schematic Editor in Eagle
(Reprinted with permission from Arduino.)

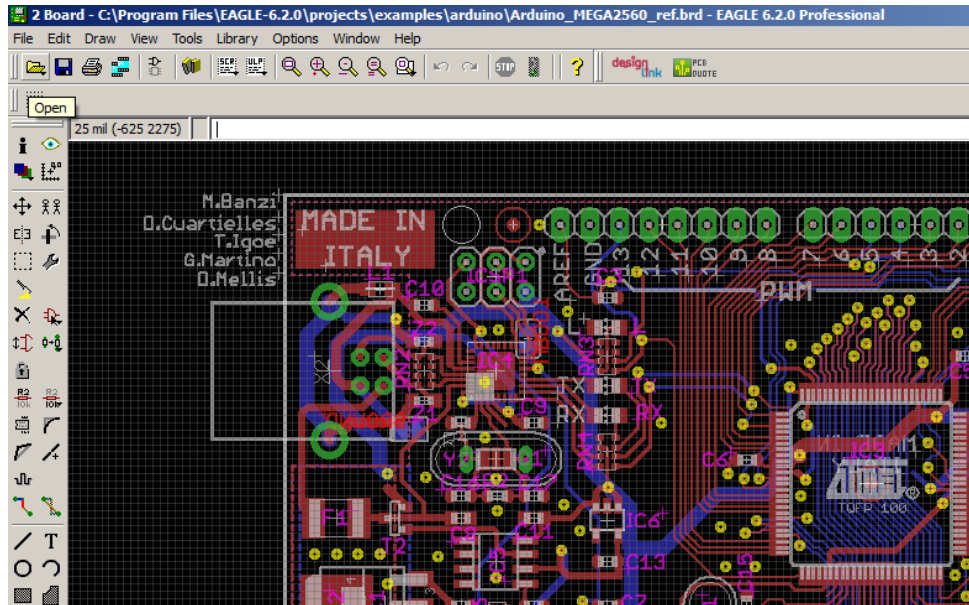

Figure 5-2 – Screenshot of Layout Editor in Eagle
(Reprinted with permission from Arduino.)

The microcontroller chosen for the system control board is the ATmega328-PU manufactured by Atmel. This microcontroller will be used because the final design for the video subsystem uses a Wi-Fi camera. This means the 32-bit processor is not needed to handle the video stream. This part meets the needs of the project without having a lot of extra features and capabilities that would go unused for this product. It has 23 I/O pins that will be sufficient in number for the communication lines to each of the peripherals in the project. It has 32 Kbytes of flash memory to allow for programming and reprogramming of system functions. This microcontroller has the unique advantage of being the same microcontroller that comes with the Arduino Uno. Due to the Arduino Uno's widespread use

there are many sources of information for the ATmega328-PU. This microcontroller is available online from Digi-Key.

The component chosen as the USB host interface for the system control board is the CP2102 chip manufactured by SiLabs. This part has a female USB port attached to a small PCB with the CP2102. The chip on the board is a USB to UART bridge which processes the incoming USB and transfers it to UART so it can be used by the microcontroller. It is USB 2.0 compatible as well as Windows 8/7/Vista/Server 2003/XP/2000 compatible. This allows for flexibility in use with multiple systems. The side opposite of the USB port has I/O pins for easy interfacing with the system control board. The CP2102 chip and also the breakout board are available online from SparkFun.

The Wi-Fi module chosen for the system control board is the CC3000EM manufactured by TI. It contains the CC3000 chip and breakout board or evaluation module. This processor is optimal for use in combination with low power microcontrollers such as the ATmega328-PU. It is a wireless network processor self-contained on the evaluation module. It uses IEEE 802.11 b/g protocol and IPv4 TCP/IP Stack protocol which meets the requirements of the project. The CC3000EM is available online from TI.

The component chosen as the GPIO interface is the Break Away Female Header which is part number PRT-00743. The headers come standard with a single 30-hole row with standard spacing of 0.1 inches. The header can be customized to size and number of holes by cutting off the excess or unwanted holes. Two separate headers will be used on the system control board, one for input and the other for output. The PRT-00743 is available online from SparkFun.

The power components on the system control board consist of the power jack, regulators, resistors, and capacitors. The power jack chosen for the board is the KLDVHCX-0202-A manufactured by Kycon. It meets all of the power requirements of the power jack component including having an integrated on/off switch. It is available online from Mouser. Several regulators will be used to adjust the voltage to the necessary rating for the different components and peripherals on and supplied by the system control board. COM-00526 3.3 volt regulators will be used for components requiring an operating voltage of 3.3 volts. Com-00107 5.0 volt regulators will be used for components requiring an operating voltage of 5.0 volts. COM-00527 adjustable voltage regulators will be used for the components requiring an operating voltage of 7.4 volts. All three of these regulators are available online at SparkFun. Also, used in the power circuits are various resistors and capacitors. These are also available online from SparkFun.

5.2.2 Microcontroller Software

One advantage of choosing the ATmega328-PU as the microcontroller for the

project is the software programming environment called Studio that is provided by Atmel. This integrated development platform will be used for writing, testing, and debugging the functions that will be used to control the automated coil gun project. The programming will consist of several files and functions that will each be designed to for a specific task. Atmel Studio supports C language which will be used in the programming of the functions.

At the core of the microcontroller programming will be the main function. This function will run in an infinite loop upon startup until the microcontroller is powered off. At each iteration of the loop the main function will be communicating with every file and function used for each of the components or peripherals. Functions will be used to govern the communications between the microcontroller and the Wi-Fi module. They will be used for PWM control of each servo motor and the input received back from the servo motor's gain adjustment. Other functions will be used for the optical sensors, LED, USB interface, and coil gun firing. A potential program structure can be seen in Figure 5-3.

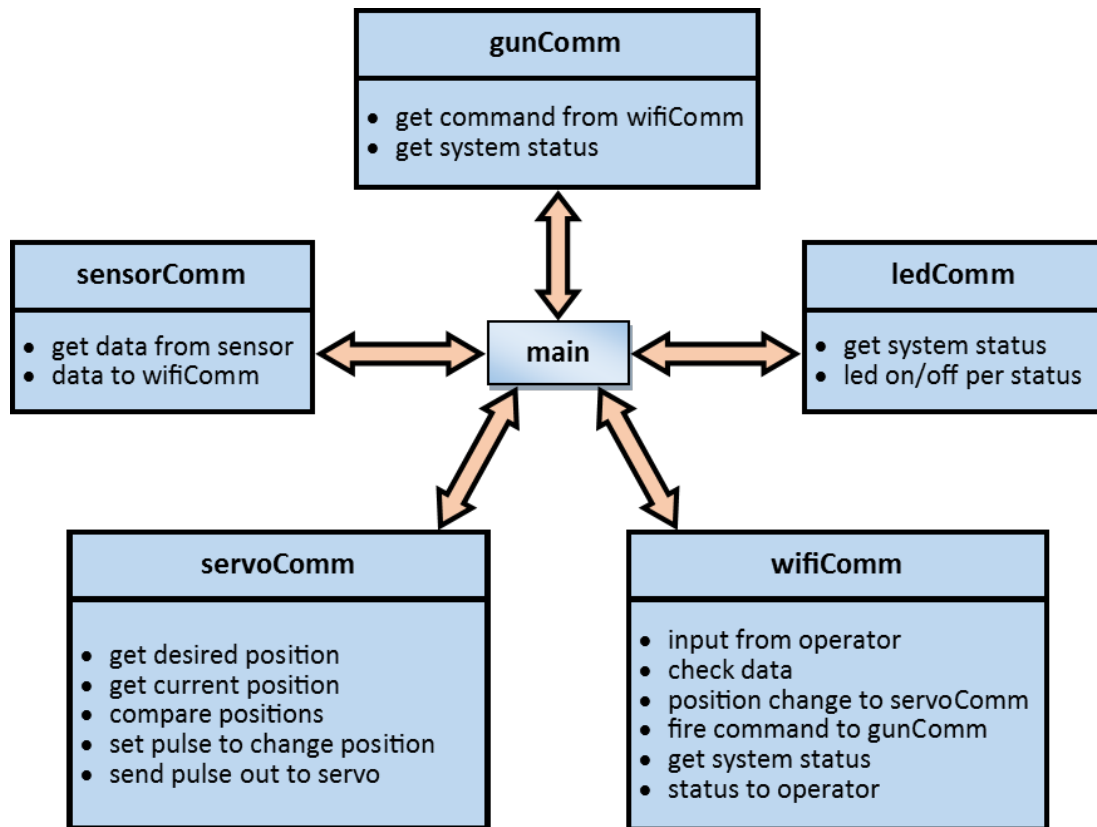

Figure 5-3 – Potential Program Structure

5.3 Final Turret Design

The turret design is finalized after sufficient calculations and research were done to meet all specifications and requirements for this system of the project. The final design consists of two major components, the servo motors and the pan and

tilt brackets used for mounting.

The mounting hardware has two separate brackets that are affixed to each other to give movement on two axes. The first part is mounted on the bottom and allows for the panning movement. It provides 180 degree coverage on the horizontal plane. The part chosen to meet the needs of this component is the DDP 155 Base Pan. It has a sturdy cylindrical shape with a top plate that rotates. It is made out of ABS plastic, has aluminum standoffs, and a ball bearing to provide a smooth movement and rigidity to the platform. This pan system also supports closed-loop feedback that will be implemented for the servo that will be mounted into the cylinder. The DDP 155 Base Pan part accommodates any standard size servo motor manufactured by Futaba or Hitec. It is available for purchase online from ServoCity.

The second mounting part is attached directly on top of the DDP 155 Base Pan. It allows for the tilting movement. It's coverage in the vertical plane will be limited to 45 degrees to meet project specifications. The part chosen to meet the needs of this component is the DDT 540 Direct Drive Tilt. Like the Base Pan it is made out of ABS plastic, has aluminum components, and has bearings for smooth motion and sturdiness. It has an underslung cradle design which keeps the center of mass close to the pivoting point. The tilt system also supports closed-loop feedback which will be implemented for the servo mounted to the side bracket of the tilt system. The DDT 540 also accommodates any standard size servo motor manufactured by Futaba or Hitec. It is available for purchase online from ServoCity.

The other major component in the turret system is the servo motor. Two separate servo motors are used. However to keep the design as simple as possible the same model of servo motor will be used for both the horizontal movement and the vertical movement. The vertical movement requires more torque and therefore its requirement for torque was used for selecting the servo motor model. The model chosen to meet the needs of the system is the Hitec HS-5585 MH. This servo motor can be operated at 6.0 volts or 7.4 volts. For this project they will operate at 7.4 volts to fulfill the torque needed. At this voltage the servo can provide a torque of 236 ounces per inch. According to calculations done earlier in the report this is sufficient for giving full range of motion. The model chosen has ball bearings and heavy-duty metal gears to further support the sturdiness and smooth motion of the turret system. This is a standard size servo motor and will fit well with the pan and tilt brackets chosen for the turret. These servo motors are available from many online retailers including ServoCity.

6.0 Prototype Construction

6.1 Gun Components

By choosing the 8 millimeter steel rod the fabrication of a customizable projectile can be easily achieved by cutting the rod into various lengths using a saw with a metal cutting blade, hacksaw or a grinder equipped with a cutting wheel. By customizing the length of the projectile the max muzzle velocity can be achieved. Once the optimal projectile length is determined, multiple projectiles can be fabricated to allow for semi-automatic firing. After cutting the rod to the determined length any burs or sharp edges need to be removed to keep the projectile edges from catching on the barrel walls. The edges of the projectile can be smoothed using a file, grinder or Dremel tool. The grinder or Dremel tool can also be used to round the nose of the projectile to improve its aerodynamics and flight.

The PVC barrel also allows for easy fabrication once all the components have been tested and the best location for the optical sensors, projectile loading and overall length have been determined. The holes to allow the LED beam to pass through the barrel can be drilled using a drill press or a jig to ensure the holes are drilled perpendicular to the barrel. The slot that needs to be cut to allow the projectile to be loaded will be a little more complicated. The best way to create this slot is to build a jig that orientates the barrel to keep the holes for the optical sensors and the slot in line with each other. The jig will also need to be constructed to allow a router to be used to cut the slot. A router will be used because the depth of the cut can be adjusted and the jig will determine the length of the slot. An 8 millimeter bolt will be affixed in the end of the barrel to secure the projectile in the firing position by attaching a permanent magnet to the head of the bolt.

The fabrication of the coil can be achieved by creating a jig and winding the coil by hand. The jig seen in Figure 6-1 was created using a piece of 5/16 inch threaded rod, a piece of the barrel cut to the length of the coil, washers and wing nuts. The barrel was used to wind the coil onto it to establish the correct inner diameter. To fabricate a tightly wound coil the magnet wire needs to be wound one layer at a time. After winding each layer super glue, epoxy or insulating varnish needs to be applied to secure the magnet wire in place, resulting in a tightly wound coil. Using the insulating varnish gives an additional benefit by increasing the dielectric of the coil, which helps to direct the magnetic field towards the projectile. The disadvantage of the insulating varnish is that it needs to be baked on to allow the varnish to cure once it is applied.

A housing or square tubular frame will be fabricated out of a clear acrylic sheet to add physical strength, to allow the mounting of components and the integration of subsystems for the gun. Figures 6-2 and 6-3 show the prototype of the housing and dimensions, where the tube and barrel will be supported with mounting

brackets that will also be used to secure the acrylic sheets that make up the sides of the tubular housing. The brackets will be fabricated out of 1 inch square solid rod that will be cut 3/8 to 1/2 inch thick. The mounting brackets will be drilled and tapped so that the housing sides can easily be removed allowing accessibility to components for any changes or repairs that might be needed. The acrylic sheets that make up the sides will also be drilled and tapped to secure components in place and attach the coil gun to the turret. [1]

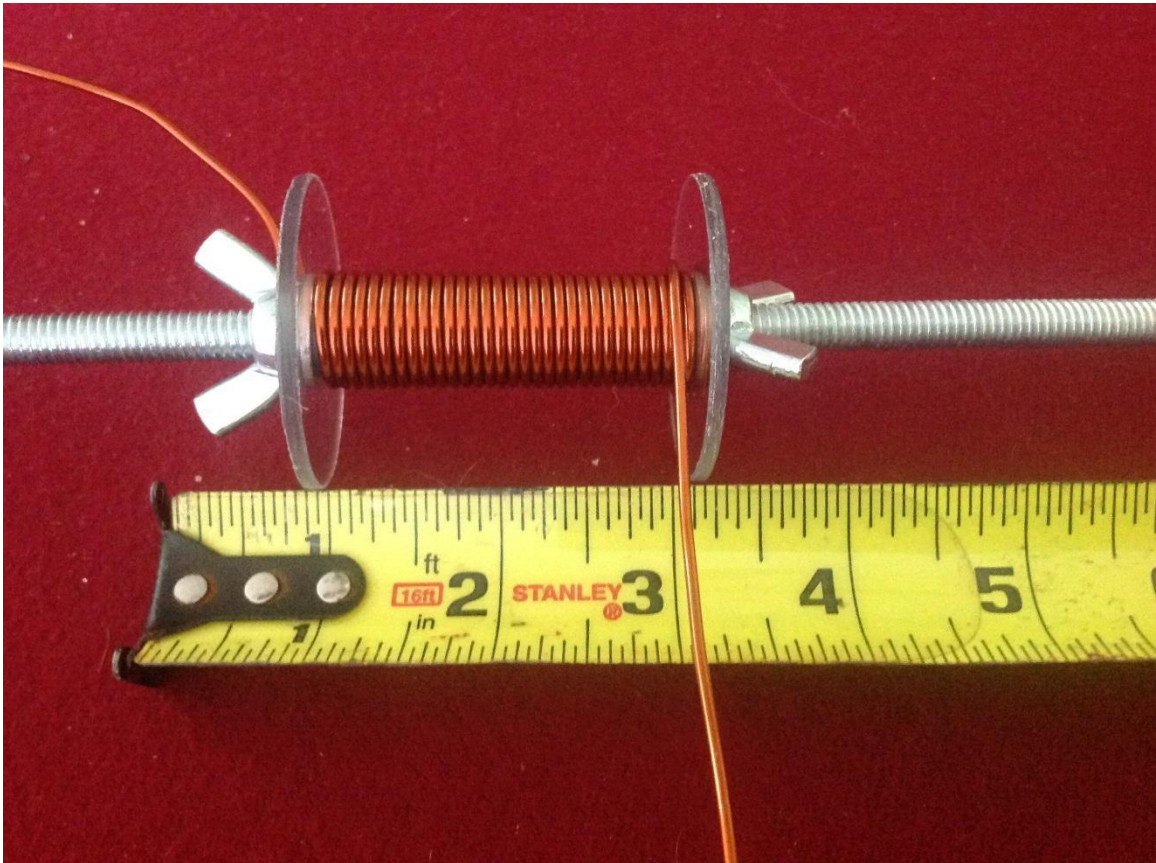

Figure 6-1 – Coil Fabrication Jig

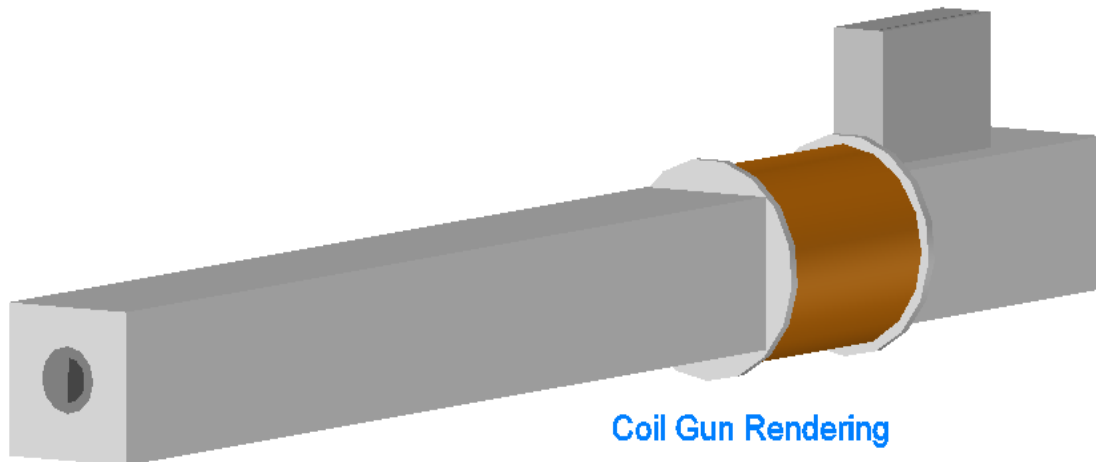

Figure 6-2 – Coil Gun Rendering

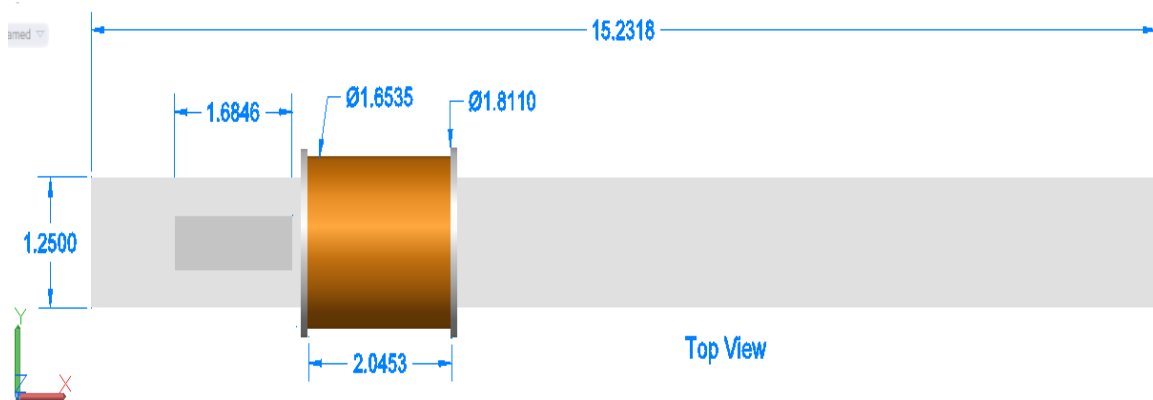

Figure 6-3 – Coil Gun Dimensions

6.2 Microcontroller Prototype

The automated coil gun's microcontroller development will be a process that is broken down into several different steps. The last step for trials and testing begins with the building of functional microcontroller prototypes. Prototyping allows for further design development with the added ability to test different concepts. Two prototypes of the microcontroller will be made in all. The first one will be temporary and is built on a breadboard. The second one will be the prototype on a PCB and will be the final version built for this project.

6.2.1 Breadboard Microcontroller

The first functional prototype will be designed and built on a solderless breadboard. This process of prototyping will unfold in several separate stages. Each stage of the breadboard build will be temporary in order to experiment with different components and circuit designs. During the process of constructing the circuits of the microcontroller on the breadboard a high emphasis will be placed

on the organization and neatness of all wiring and components. Often complex breadboard builds with microcontrollers have circuits that can become very complicated when a lot of wiring is required. Examples of what the breadboard prototype will look like can be seen in Figure 6-3. Also seen in Figure 6-4 is what will be avoided in the build of the breadboard.

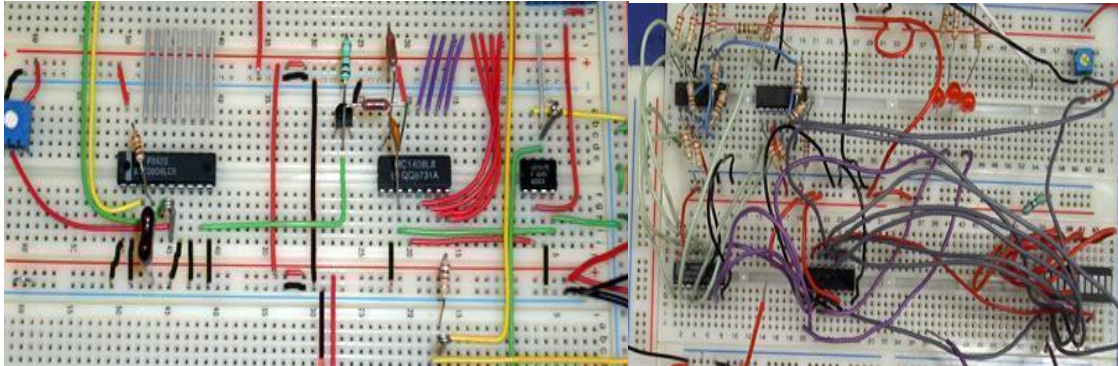

Figure 6-4 – Desired Breadboard (*left*), Wiring to be Avoided (*Right*)
(Reprinted with permission from Nick Reeder.)

The first stage of the breadboard prototyping will start with the configuring and testing of the individual components in combination with the microcontroller. Using jumper wires the components will each be connected to the microcontroller for their initial individual configuration. This process will be done for each of the parts separately. Once each component is configured to achieve the desired results they will be integrated together. As the breadboard design becomes more finalized, cut wires will be used to provide a cleaner and more organized wiring layout.

This prototyping process will first be done for the USB host interface because it will be needed for programming the microcontroller for the integration of other parts. The servo motors will use this procedure to set up the PWM and fully closed-loop feedback. The Wi-Fi module will be set up to configure communications between the operator's mobile device and the microcontroller. Optical sensors will first be used alone with the microcontroller for the detection of objects. After that is configured correctly, the LED will be set up as well. When the optical sensors and the LED are working properly they will be implemented together so that the LED will indicate the presence of a projectile. The PCB power jack will also go through the breadboard prototyping stage to create an environment for designing and testing the PCB's power subsystem.

6.2.2 PCB Microcontroller

After a breadboard prototype has successfully been completed to meet all project requirements a PCB microcontroller prototype will be created. This is a much more finalized version of a prototype. When the PCB is made its permanent and further design changes cannot be implemented without having to have a completely new PCB made. The PCB microcontroller prototype is the final

functional prototype that will be used. Once all testing on this prototype is done it will be the one that is integrated into the final automated coil gun system.

The first step of the PCB prototype is designing the schematic and physical layout of the PCB. This design step is done using Cadsoft's PCB design software, Eagle. Using this software the schematic for the PCB will be constructed based on the breadboard layout of circuits and components. From the schematic, Eagle has the ability to populate layout editor with all of the parts used in the schematic design. The components can then be dragged and dropped onto the virtual board to finalize the exact layout of the PCB. The PCB can then be ordered. Once it is received the prototype is completed with the placement of components onto the board. This placement of components will be done systematically as done with previous prototypes to allow for testing and trials of individual components, the interaction of components, and finally the system as a whole.

6.3 Supply Power

The supply power for this project is provided by a common wall outlet. The prototype construction of the supply power circuit be done on a breadboard or prototype board. Care should be taken when using a breadboard since high voltage and high currents will be used. The high current will not be pushed through the breadboard since appropriate wiring gauge will be needed to handle this. The low voltage supply power to the microcontroller should be able to be done on a breadboard. The prototype for this low voltage circuit (refer to Section 3.11.1) will be constructed on a breadboard and measured with an oscilloscope. The construction on the breadboard will also be done in an orderly fashion so that proper analysis and troubleshooting can be performed easily, instead of dealing with a wired mess. The circuit should look like the one shown in Figure 6-4 on the left in Section 6.2.1.

The high voltage circuit will not be constructed on a breadboard since the risk of melting or burning plastic is not desired. The prototype circuit for the high voltage can be constructed in a separate open box that will be able to dissipate heat. The wiring will need to be the appropriate gauge in order to handle the high current.

6.3.1 Equipment Housing

The equipment for the prototype needs to be contained in a neat and orderly manner. This will allow for easy troubleshooting and all the related equipment to be in the same area. The use of a "project box" or a similar heavy duty box, such as a tackle box, that can contain the electronic components, microcontroller, capacitors, and other parts can be purchased or constructed. An example of a box that can be used to contain these components is shown in Figure 6-5.



Figure 6-5 – Common Project Box
(Awaiting Permission from InventGeek to Reprint.)

The use of these boxes is not to just organize the components. They also serve to protect users and builders from electrical shock that can occur, especially with the capacitor bank fully charged. It is crucial that the capacitors be isolated from touch and from other electrical components since an arc connection can occur that will either shock someone or destroy other electrical parts, such as the microcontroller.

The final design of the coil gun will contain project boxes that are similar to the one shown in. However, the final design will be more organized and compact than the prototype. While making the final design as compact as possible is wanted, the heat constraints of the capacitors, power supply, and coil may not allow such a design. Other components such as fans or heat sinks can be added in order to dissipate heat, however a fan needs power to run and both of these components make the device more bulky. A design that will minimize space and maintain performance will be sought in order to keep the turret compact.

6.3.2 Wiring Harnesses

Wires are inevitable electronics design. Designing a prototype can quickly lead to a wiring mess that can be confusing to follow and very difficult to troubleshoot. Therefore, it is necessary to include an organized wiring diagram or at least an easy to follow wiring path in the design. The use of a wiring harness will accomplish this. An example of a wiring harness is shown in Figure 6-6.



Figure 6-6 – Common Wiring Harness
(Awaiting Permission from Crutchfield to Reprint.)

Wiring harnesses are found in car stereo equipment, boats, planes, etc., and are a common way to keep organization in design. They also help ensure safety because it is more difficult to incorrectly wire something, such as mixing the power line with a signal line. It is necessary that wiring harnesses or the use of zip ties or similar way to organize the wires be in place in both the prototype and the final design.

7.0 Prototype Testing

7.1 Bench Testing

7.1.1 Charging Circuit

The charging circuit for this project is very important to test. The charging circuit determines how the capacitors will be charged and also how quickly the firing rate of the coil gun. The firing rate will also be attributed to the charge and discharge speed of the capacitors, which will also be tested (refer to Section 7.1.6). Testing the charging circuit can be accomplished by using a breadboard or similar prototype board to make a circuit that will mimic the actual printed circuit board that will be designed. The designed charging time for the capacitors was simulated and shown in Figure 4-20 in Section 4.12. The assumption was that the capacitors have a charge time of three seconds. A charging circuit can be constructed in order to test this design.

A typical charging circuit for a coil gun uses a thyristor as a switch. An example circuit of what will be constructed is shown in Figure 7-1.

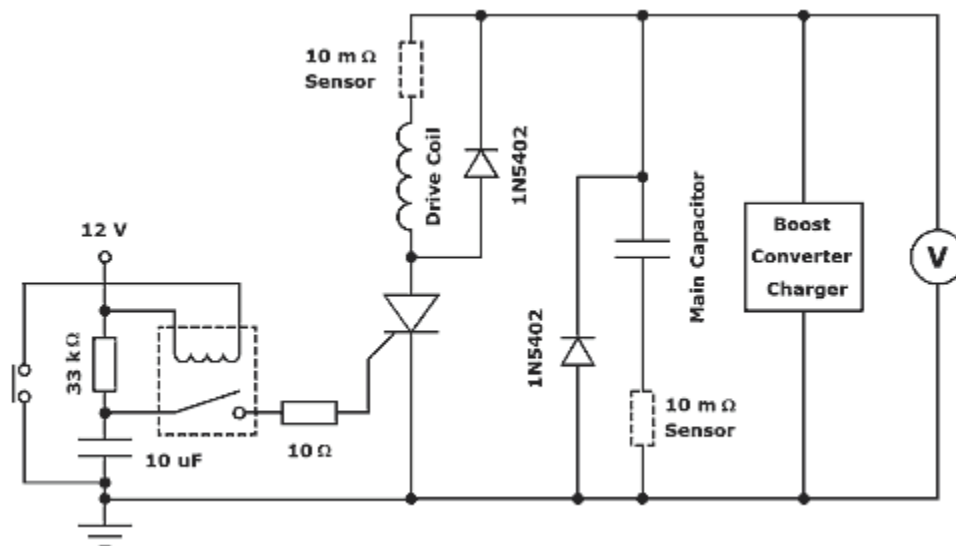

Figure 7-1 – Thyristor Fired Coil Gun Circuit
(Awaiting Permission from James Paul to Reprint.)

The values of these voltages, resistors, and diodes for the circuit for this coil gun design will be different. The use of a boost regulator will not be used in this design. The use of a transformer to step up the voltage will be used and after rectification a steady supply voltage of 480 volts will be available. For this coil gun design, the circuit will look more like the one below in Figure 7-2.

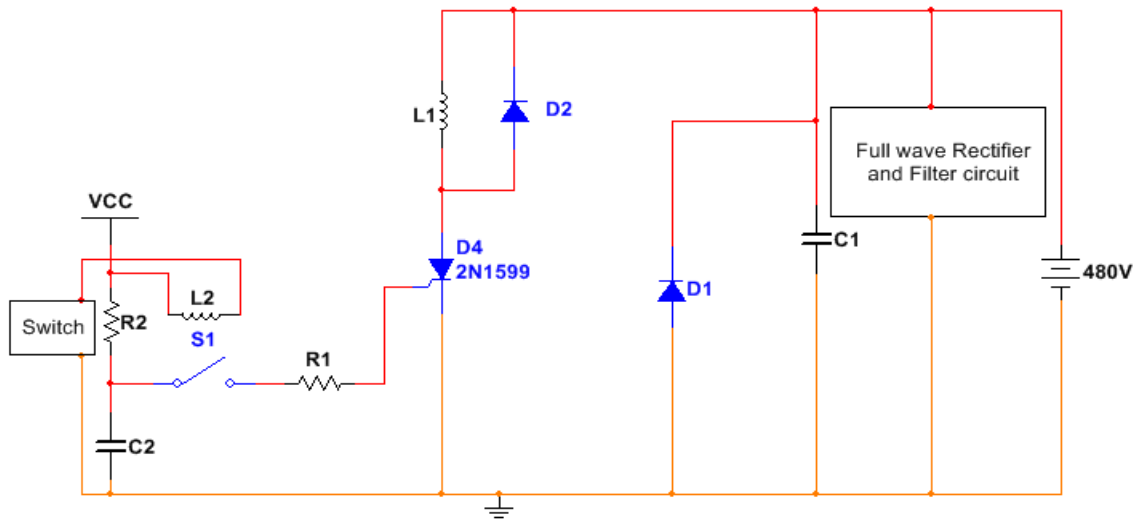

Figure 7-2 – Designed Firing Circuit for Coil Gun

Once this circuit is constructed, it can be tested using by charging a capacitor and measuring the voltage with an oscilloscope. The behavior of the charging circuit can then be graphed and the response of the charging circuit will allow a better prediction of the actual charging and discharging circuit response.

7.1.2 Gun Components

The components that make up the coil gun will be tested individually in the senior design lab before it is assembled to check for any problems with the design. By testing and troubleshooting the components individually the design can be finalized before time and money is spent on the fabrication of the finished product. The operation of the components will be simulated experimentally in a controlled manner to test and measure the response of the component for the temperature, current, output, velocity, efficiency and overall operation.

7.1.2.1 Coil and Projectile

After the coil is fabricated the resistance and inductance of the coil will be measured to check that values are within the expected values calculated in the design. The inductance can be measured by placing the coil in series with a resistor box and applying a voltage using a small control transformer and adjusting the resistance until the voltage drop across the resistor box and the coil are the same. The resulting resistance is the reactance of the circuit and can be entered into equation 7-1 to determine the coil's inductance. The first test of the coil's operation will be performed by charging the capacitors to 100 volts limiting the energy to see how the coil functions and check for any major problems that may be caused by coil fabrication or the design of the coil. The coils current will be measured and any increase in temperature will be noted to determine if the capabilities of the coil design are limited. This process will be repeated to determine the maximum current pulse that can be applied to the coil before failure occurs, by increasing voltage and number of capacitors. The rise in

temperature will be determined using equation 4-23 by measuring the change in resistance of the coil after each firing of the projectile. The results will be used to create a graph of the coil's temperature versus number of shots.

$$L = \frac{X_L}{2\pi f} \quad (7-1)$$

Then the output velocity that the coil is capable of producing will be determined. This will be conducted using a vertical speed trap experiment described in section 3.8, by setting the coil gun on a level surface and firing the projectile into a target and measuring the fall to calculate velocity. This will be performed varying the magnitude of the source, the length of the projectile and the firing position to determine the optimal combination of parameters. While the velocity measurements may not be exact they should be close enough to determine if the coil gun is operating satisfactorily and establish the firing parameters.

7.1.2.2 Firing Position

By setting up an experiment the starting position where the force on the projectile is greatest can be determined. The setup of the test seen in Figure 7-3 will be performed using the steel rod cut at lengths of 38, 32, 25 and 19 millimeters. The test is performed by incrementally moving the projectile into the coil and at each point finding the voltage at which the projectile is sucked into the coil. The test will start with the coil 10 millimeters higher than the length of the projectile and lowered at 1 millimeter increments, noting the supply voltage and position for each step. The results are then entered into equations 7-2 and 7-3 to determine the firing position and force respectfully to generate a graph of the force vs. starting position. This test can help to determine the optimal starting position of the projectile but would have to be compared with results at actual firing energies where the LC time constant of the coil timing may produce different results.

$$d_{\text{into coil}} = l_{\text{projectile}} - h_{\text{coil}} \quad (7-2)$$

$$F = \frac{V_{\text{max}}}{V_{\text{applied}}} \quad (7-3)$$

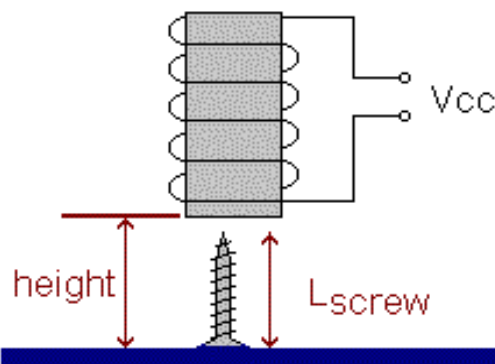

Figure 7-3 – Measuring Coil Strength at Different Firing Positions
(Reprinted with permission from Barry Hansen.)

7.1.2.3 Velocity Detection

To calculate an accurate muzzle velocity of the projectile the circuit in Figure 4-10 will be built using a breadboard and testing the operation of the optical sensors alone. The optical sensors will be temporarily mounted mimicking their placement in the barrel and the projectile will be placed in between blocking the infrared beam. The output of the comparator will be measured as the projectile is moved across the sensors using an oscilloscope so that the response can be seen. Then the sensors will be attached to a mock barrel to check for any discrepancies in the output that may be caused by sensor placement in relation to the barrel. The arrangement of the sensors can be adjusted to allow for correct sensing of the projectile. The proper design of the optical sensors will then be verified by mounting the sensors to the finalized barrel and holding the barrel vertically the projectile will be dropped through it and using the microcontroller and known distance between the sensors the velocity can be calculated. The result can be compared to the expected velocity based on gravity and mass of the projectile.

7.1.3 Turret Control

Testing of the turret control subsystem of the automated coil gun will be done at many times throughout the development process. Initially testing will be on individual components before they are integrated with other parts. This type of testing allows for problems to be diagnosed more quickly and the tester does not have to sort through multiple components to identify the source of the problem. This in turn will lead to a better turnaround time on the process of fixing any bugs or problems in the turret system. After each individual component has satisfied the tests and fully meets the requirements of the project it can be integrated with other parts that have met their respective criteria.

The individual components of the turret and control system are the servo motors, the GPIO pins, the microcontroller, the Wi-Fi module, and the operator's mobile device. The servo motors will be tested individually with one servo motor having to achieve a range of motion of 180 degrees. The other servo motor will have to achieve a range of motion of 45 degrees. The servo motors will have to display a quick reaction time with smooth and controlled movements. The GPIO pins will be tested to safely handle the current and voltage that they will be required to transmit to the servo motors. The microcontroller will initially be programmed to produce a PWM signal for initial testing of the communications interface between it and the servo motors. The fully closed-loop feedback system implemented will be monitored to ensure the microcontroller is receiving the correct signal that corresponds to the servo motor's current position. In a separate testing environment the Wi-Fi module will be interfaced with the microcontroller and communications between the two will be tested. After that is successfully completed the microcontroller's program will be adapted to be able to respond to signals transmitted through the Wi-Fi module from the operator's mobile device.

These signals will be used to control the PWM signal delivered to each servo motor.

Upon successful completion of testing, the turret and control subsystem will have the following functions fully operational:

- Turret movement control from operator's mobile device
- Wi-Fi communication between the microcontroller and mobile device
- Microcontroller tracking of current servo motor positions
- Horizontal range of motion up to 180 degrees
- Vertical range of motion up to 45 degrees
- Smooth, controlled movements

Once all components have been individually tested, integrated with the other parts of the turret and control system, and has been successful in meeting the functions listed above it can then be integrated with the rest of the project components. The coil gun, video subsystem, and power subsystem will each be joined with the turret subsystem. Each of these additions will be made one at a time and after each subsystem is added the turret subsystem will be retested to ensure that with each addition it still meets the requirements of the project.

7.1.4 Firing Modes

The three different firing modes can be tested by creating a circuit that imitates the function of the switching circuit. This circuit will be built on a breadboard or a similar project board that is able to handle the high currents required of this coil. An oscilloscope or digital multimeter can be used to measure the voltage that the circuit i.e. the capacitors, have been charged to. The capacitors will then be discharged and the voltage across the capacitors will drop to a low value (theoretically zero after an infinite amount of time).

For the first firing mode, which is a single fire mode aimed at firing at the projectile at the specified 120 feet per second, will use the energy stored in two capacitors to achieve this speed. This will be tested by charging the two capacitors, discharging them through the switching circuit, and measuring the speed of the projectile. There are multiple methods that can be used to test the speed of the projectile which will be discussed in Section 7.1.2.3. A schematic of the testing circuit for the first firing mode is shown in Figure 4-22 in section 4.12.1.

The second firing mode is a semiautomatic mode that will allow the user to fire successive projectiles. In order to allow more projectiles to be fired, only one capacitor will be discharged for this firing mode. This means the speed of the projectile will be lower since the energy and thus current in the coil will be lower. Again, the method used to determine the speed of the projectile can vary, however the same method for measuring speed will be used for each firing mode. An oscilloscope would be the best measuring tool for testing this firing

mode since the spikes of each capacitor discharge will be observable. The testing circuit for this second firing mode is shown in Figure 4-23 in Section 4.12.2.

The last firing mode that will be tested is the burst firing mode. This will fire three successive shots every time the coil gun is fired. Again, one capacitor will be used for each projectile fired, however three will be discharged after a short delay. Again, for this firing mode an oscilloscope will be ideal to measure the discharge circuit and observe the behavior. For each one of these firing modes, a simulation can be created using Multisim and similar software programs in order to simulate the different firing modes. The testing circuit for this third firing mode is shown in Figure 4-24 in Section 4.12.3.

7.1.5 Control App

In order to properly test the control app, all other features of the automated coil gun must be working properly, and because of this, it was one of the last things to be tested. Once all the other individual components of the automated coil gun were working, each individual component could be tested by using the control app itself. The features that needed to be tested were communication to the wireless module on the PCB, operation of the servo motors, the firing mechanism, live feed from the wireless camera, changing of firing modes, accurate reading of the voltage sensor displayed, and the system as a whole.

The process of connecting to the PCB and live feed from the wireless camera had similar testing environments and concerns, allowing them to be tested in unison. The tests needing to take place were changing of geographic location, loss of internet connection, and physical distance. All had the potential to make the application fail without proper error checking and needed to be taken care of before advancing.

The next test to be taken all involved communication between the PCB and the control app, which is why the above test were needed to be performed first. Tests involved in this process involved the reading of the voltage sensor accurately, operation of servo motors, and the changing of firing modes. The testing behind this required that the commands were being encoded and sent properly, while providing error checking with a service such as TCP. If this was not tested, improper signals could be sent, which, in turn, could give an unwanted operation or improper readings which would provide a lack of feedback to the user. This would make it much more difficult to pinpoint potential problems.

Once all of these features were tested individually, the whole system needed to be tested in order to make sure one feature would not affect, or even break, another. A problem like this could be caused by a different object if the software could read input that is not meant for its use, which throws an error exception, or

worse, misuses these signals. Once everything was tested simultaneously, the prototype could be verified as working properly.

7.1.6 Capacitors

Capacitors that are obtained from various manufacturers have different tolerances, max voltage ratings, etc. For certain applications, it is important for the capacitance to be exactly what the manufacturer states it is. For more delicate devices, or those requiring high accuracy, a low tolerance value is desired. This often leads to higher prices and for this project, high tolerance values are not required. However, since the capacitors are being purchased from outside retailers and may be used or old, it is important to have them tested to ensure they fall within the specifications on the label.

There is a technique for “restoring” capacitors in order to improve performance and operating safety. This is called reforming capacitors. The process simply involves applying a steadily increasing voltage to the capacitor in order to restore the internal dielectric material. When a steady voltage is applied to the capacitors, the internal current should drop to zero (or at least the rated leakage current) since a constant voltage on a capacitor is modeled as an open. For the 1800 microfarad, 480 volts capacitors used in this project, a constant DC voltage source can be applied up to 400 volts. It is important that an ammeter be placed in series with this circuit and the current measured to ensure the capacitor doesn’t breakdown. If the capacitor does breakdown during this testing process, large amounts of current can be drawn and it can explode, therefore caution must be taken. Each capacitor must be tested separately to ensure the rated parameters are met. An example of the simple circuit that is used for this testing circuit is shown in Figure 7-4. The parameters that will be used will be an input voltage of 400 volts for 10 minutes and the output voltage and current will be measured.

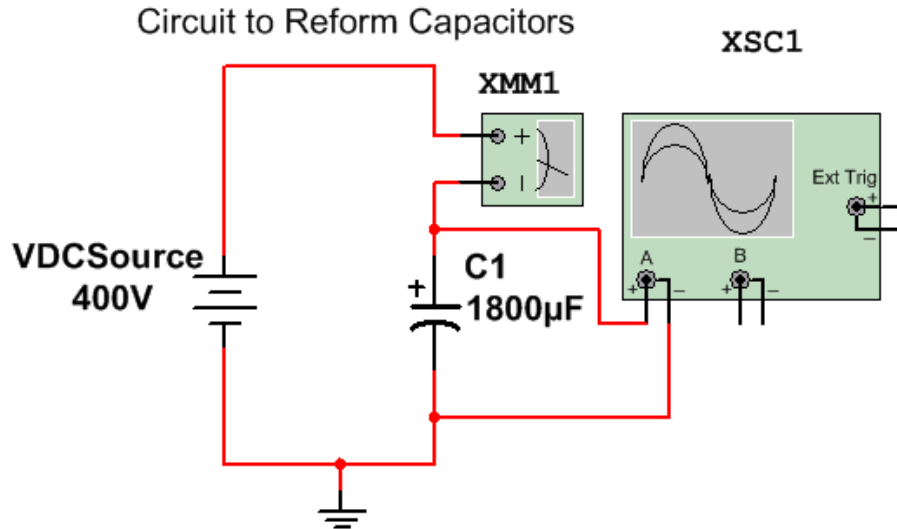

Figure 7-4 – Reforming Circuit for Capacitors

The energy stored in each capacitor then needs to be discharged. This is a lot of energy in each capacitor and using typical small wattage resistors won't effectively or safely discharge them. One solution is to use light bulbs to dissipate the stored energy. Light bulbs are good high wattage resistors and they dissipate heat effectively. Using 60 watt light bulbs, the energy from each bulb can be dissipated safely. The light bulbs will be connected in series in order to dissipate more energy (Energy dissipation is desired here so inefficiency and heat dissipation in the circuit is the goal). The circuit made to discharge the circuit is shown in Figure 7-5. [1]

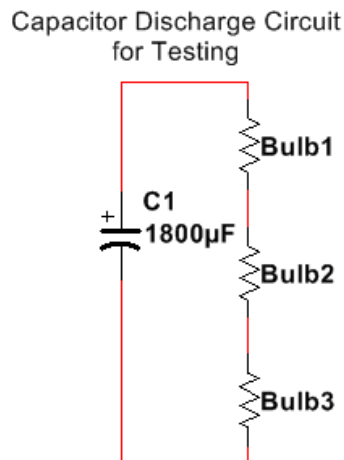

Figure 7-5 – Discharge Circuit for Capacitor Testing

7.2 Field Testing

After the successful testing of all individual subsystems, they will begin to be integrated together for final field testing. This testing will be carried out in several

phases. The first phase will be integration testing and will entail testing the system after each subsystem is added. After each subsystem is integrated into the final project prototype the next phase of testing can begin. This testing will be done on the project as a whole in the controlled environment of the Senior Design Lab in the Engineering building. This step will be used to evaluate the system as a whole with the ability to quickly diagnose problems with the equipment that is readily available in the Senior Design Lab. The last phase will be the actual field testing where the final project will be taken outside to be tested in the environment that it will be in for the final presentation. The environment will have to be an open area where the coil gun can be operated safely but still have access to a power source. This step of testing will allow the group to better understand the capabilities of the project with regards to projectile distance and accuracy. A shooting range will be set up with targets placed in the field of fire to track accuracy. Distance markers will be set up to track the distances the projectile travels within each firing mode. The testing will conclude when the project meets all specification requirements to the satisfaction of the group.

7.3 Efficiency

The efficiency of this design can be tested by comparing the potential energy stored in the capacitors and the kinetic energy of the projectile. The potential energy of the capacitors can be found using Equation 4-9 in Section 4.3. The potential energy of two capacitors at 350 volts was calculated to be 221 Joules. The testing circuit can be constructed and an oscilloscope or digital multimeter can be used to measure the exact voltage on the capacitors once fully charged. The exact capacitance values of the capacitors will be measured using a digital multimeter. Therefore, the exact potential energy stored within the capacitors can be actually measured.

In order to measure the projectile, a circuit that replicates the charging and switching circuit will need to be constructed. The coil will also need to be constructed. The use of one capacitor that can be charged, a switch, and the coil will be enough to launch the projectile. Though this will be a crude contraption compared to the final design, it will be enough of the prototype to measure efficiency.

To test the kinetic energy of the projectile, the velocity will need to be measured. There are multiple methods that could be used to measure the velocity of the projectile. There is an older method to measure the velocity, called a ballistic pendulum, of a projectile that catches the projectile into a wood block. The approach of setting up this method is discussed in detail in Section 3.8.1. The potential energy of the block can then be compared to the kinetic energy of the

projectile. If some assumptions are made, conservation of energy can be assumed and the conservation of energy and momentum equation applies. The setup of this contraption is shown in Figure 7-6.

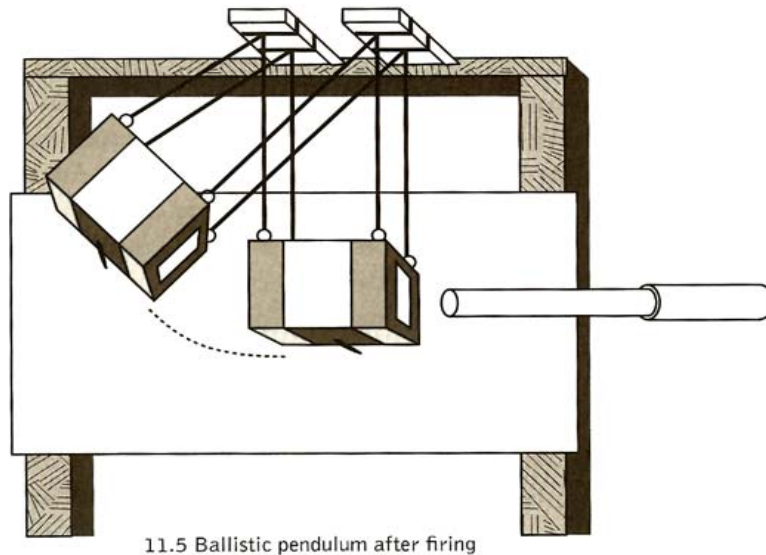

11.5 Ballistic pendulum after firing
Figure 7-6 – Ballistic Pendulum After Firing
(Reprinted with Permission from Barry Hansen.)

The velocity of the projectile in this project will be measured with the speed detection circuit shown in Figure 4-10 in Section 4.7 in the final design. Using this circuit, which will be controlled and displayed with the use of the microcontroller, the velocity of the projectile will be measured and the kinetic energy can be determined. The velocity for the testing will be measured with the vertical speed trap. With the kinetic energy of the projectile and the potential energy of the capacitors measured, the efficiency of the energy transfer can be measured. The efficiency is the output energy divided by the input energy times 100, which is shown in equation 4-9.

8.0 Administration Content

8.1 Project Milestones

The milestone timeline for Senior Design I shown in Figure 8-1. Although, in theory, the design of the project seemed manageable, since none of the group members have built anything like this or at this amount of detail, it was hard to determine estimates for the projects milestones. In order to avoid being overwhelmed as a group, it was decided to overestimate the time to complete each task to give some leeway and avoid time crunching. The first part of the project involved research of each individual part and how it would fit in with the rest of the project. This research would take around sixty days, in order to get a full understanding of everything as a whole. This research would define the rest of the project, so it played a crucial role in everything that was done. Anything that wasn't researched would be very hard to implement on the short schedule in which the project was due.

After all the research was done, the next step was to order all the correct parts and test how they worked individually and together. As with many projects of this scale, although individual parts work as a whole, things tend to crash. For this reason, allowing plenty of time for testing was very important to the whole project. One of the biggest limitations of this project came in the form of lack of experience. Although many of the group members had a good understanding of software development and electronics, none had actually implemented something this complex. To make up for this lack of experience, the group decided to limit the features and functions of the automated coil gun to something

manageable with plenty of time to be done. Each group member having an individual part to work on allowed the milestones to be split up and worked on at the same time. For the second half of the project, the milestones were more focused on testing and implementation. These milestones are shown below in Figure 8-2.

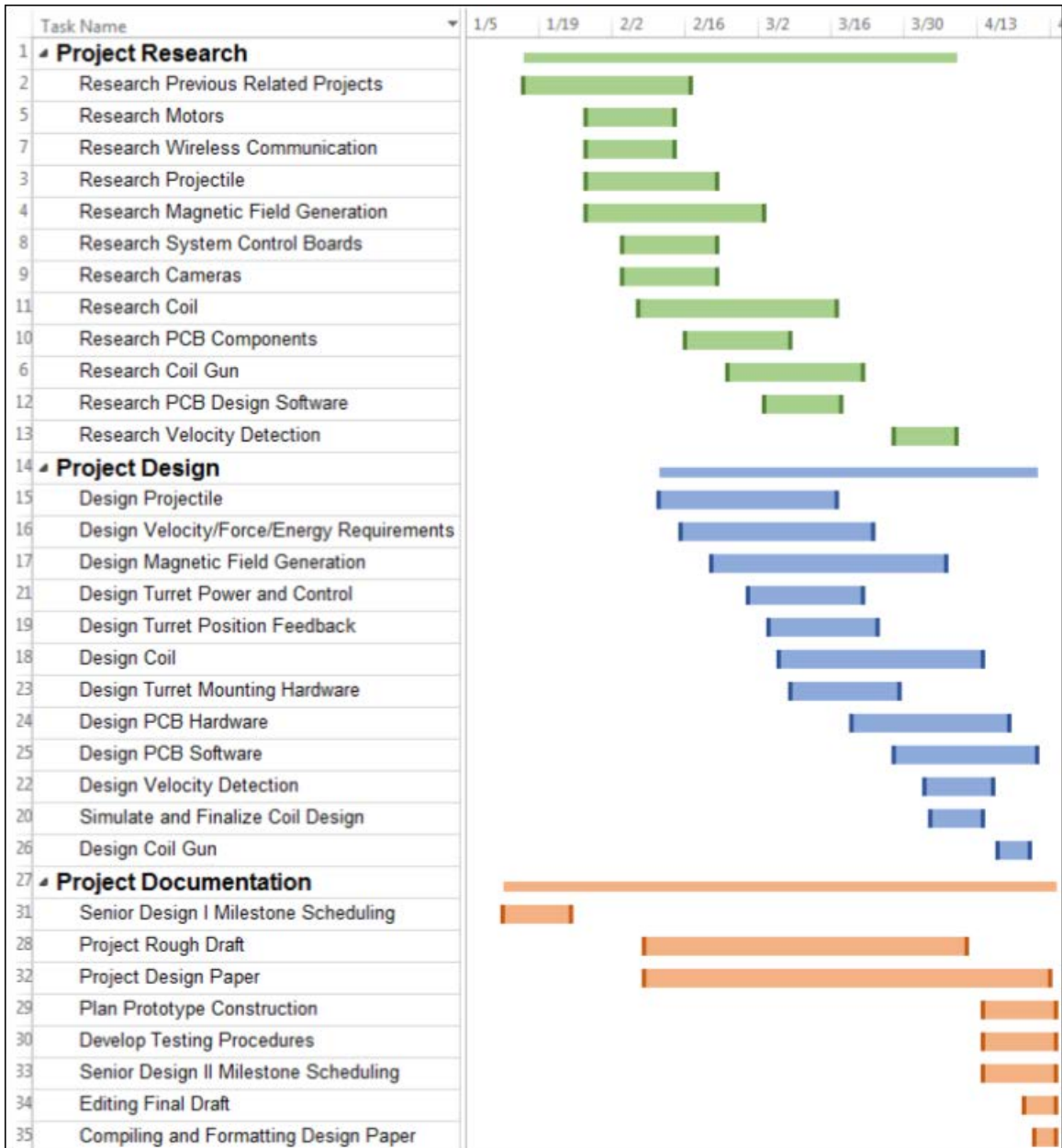

Figure 8-1 – Senior Design I Milestones

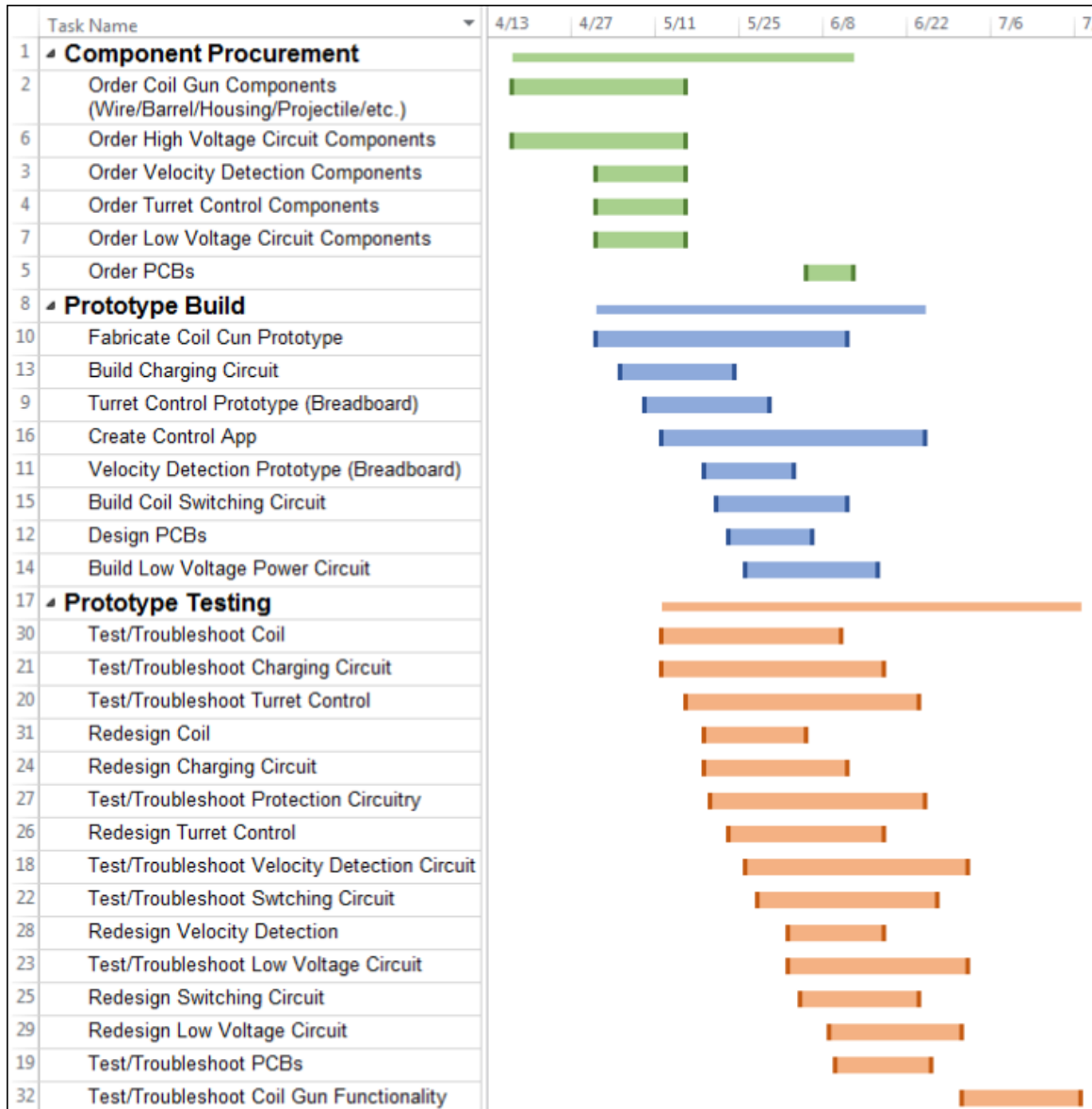

Figure 8-2 – Senior Design II Milestones

8.2 Project Budget

When creating the Automated Coil Gun, the budget was one of the most important things to consider. In order to properly estimate the budget, a large amount of research needed to be done. The first thing to research was previous projects and things currently on the market with similar features. As not many coil guns are manufactured by companies and, any that are, are on a military budget scale, this would provide no insight into the cost. The next step was to research similar projects that implemented many of the same features, as this would give the best estimation of cost. However, since no other project implemented everything the exact same way, this would only be a rough estimate.

Some things that made the estimation difficult were scrap parts. With a project such as this one, certain parts were bound to break due to the use of large amounts of voltage and a limited knowledge of how these parts will function under such testing conditions. Parts such as the capacitors, microcontroller, coil, and voltage sensor can be somewhat sensitive and the max voltage limitations given in the description manuals are only a close estimation to how they will actually function.

An important part of the research that was done was pricing of these parts. Many factors that were needed to be looked at were different prices, the quality of the part, and shipping requirements. When looking at parts for the overall project, many different companies sold the same part, so the first thing that was looked at for each of these parts was their actual price. In theory, the cheaper part should be chosen on a limited budget, but the quality of these parts comes into question. The way to overcome this limitation without trusting an unknown company was to look at reviews of the individual part and the company as a whole. The last thing to look at when choosing a part was the shipping requirements of these parts. With small and out-of-garage companies based off of websites such as eBay, an important thing to understand is when these parts would be expected to arrive. If these parts were limited to only ship once a month, this would mean that the group would not receive these parts for a month or more at a time. This would certainly prove to be a problem. This would completely change the timeline of the milestones, as parts could not be tested on time. This would ultimately push the entire project back. The best way the group found to avoid this issue was to order from bigger, well known, companies. These companies usually guaranteed a reasonable shipment date that could be worked around, while still keeping the cost to a minimum.

After all factors were taken into account, the budget could be drawn up and determined. This budget is shown below in table 8-1.

Item Description	Unit Price	Qty.	Total Cost
Magnet Wire	\$68.63	5 lbs.	\$68.63
¼ Inch PVC Barrel ¼"X3'	\$2.80	1 ea.	\$2.80
Inch Steel Rod 5/16"X3'	\$3.47	1 ea.	\$3.47
Clear Acrylic Sheets 18"X24"	\$19.98	1 ea.	\$19.98
Square Acrylic Rod 1"X1"X12"	\$6.99	1 ea.	\$6.99
Infrared LED	\$5.98	4 ea.	\$23.92
Infrared Phototransistor	\$3.86	4 ea.	\$15.44
LM393 Comparator	\$0.92	4 ea.	\$3.68
Hitec HS-5585 MH Servo Motor	\$69.99	2 ea.	\$139.98
DDP 155 Base Pan	\$39.99	1 ea.	\$39.99
DDT 540 Direct Drive Tilt	\$39.99	1 ea.	\$39.99
ATmega328-PU	\$3.41	2 ea.	\$6.82
KLDVHCX-0202-A-LT Power Jack	\$1.08	1 ea.	\$1.08
COM-00107 Regulator	\$1.95	3 ea.	\$5.85
PRT-00743 Pin Header	\$3.95	2 ea.	\$7.90
CC3000-EM Wi-Fi Evaluation Module	\$35.29	1 ea.	\$35.29
CP2102 USB to Serial	\$21.95	1 ea.	\$21.95
2 Layer PCB	\$70.00	1 ea.	\$70.00
Voltage Sensor Module	\$4.99	1 ea.	\$4.99
450 Volt-1800 micro Farad Capacitor	\$13.14	8 ea.	\$105.08
Thyristor	\$1.18	1 ea.	\$1.18
Transformer	\$34.98	1 ea.	\$34.98
Copper Bus Bar	\$16.25	2 ea.	\$16.25
Frame Hardware	\$25.00	1 ea.	\$25.00
Misc. Electronics	\$50.00	1 ea.	\$50.00
Total Cost			\$751.24

Table 8-1 – Project Budget

Appendix A – References

- [1] Hansen, Barry. (n.d.). Barry's Coilgun Design. Retrieved 2 February, 2014, from <http://www.coilgun.info/about/home.htm>
- [2] Hoehn, Ng, Reid, Von Niederhausern. (2010). Automated Coil Gun 2010. Retrieved 5 February, 2014, from <http://www.eecs.ucf.edu/seniordesign/su2010fa2010/g08/>
- [3] Dagdagan, Ko, Shashvat. (2013, March 15). Multistage Coil Gun. Retrieved 5 February, 2014, from http://courses.engr.illinois.edu/ece445/projects/spring2013/project3_design_review.pdf
- [4] Paul, James. (n.d.). Retrieved 8 April, 2014, from http://www.coilgun.eclipse.co.uk/electromagnetic_pistol_voltage_converter_design.html
- [5] Murray, Jason (n.d.). Delta-V Engineering. Retrieved 26 March, 2014, from <http://www.deltaveng.com/gauss-machine-gun/design/>
- [6] Mann, Clymer, Huant. (2012, May). *Remote Touchscreen Controlled Defense Turret*. Retrieved April 11, 2014 from <http://www.eecs.ucf.edu/seniordesign/fa2011sp2012/g11/>
- [7] Colon, Horton, Steighner, Yielding. (2011, May). *Automated Targeting Proximity Turret*. Retrieved March 15, 2014 from <http://www.eecs.ucf.edu/seniordesign/fa2010sp2011/g17/>
- [8] Michelsen. (2013, July). *Nerf Vulcan Sentry Gun*. Retrieved April 2, 2014 from <http://www.instructables.com/id/Nerf-Vulcan-Sentry-Gun/>
- [9] Murph. (2007, January). *Airsoft Project 2.0*. Retrieved April 2, 2014 from <http://www.engadget.com/2007/01/16/airsoft-project-2-0-touts-four-times-the-firepower/>
- [10] Samsung. (2013, May). *Autonomous Self Aiming Turret Robot*. Retrieved April 4, 2014 from <http://www.techeblog.com/index.php/tech-gadget/samsung-sgr-1-the-autonomous-self-aiming-turret-robot>
- [11] DoDamm. (2010, December). *Super aEgis ii*. Retrieved April 6, 2014 from <http://www.gizmag.com/korea-dodamm-super-aegis-autonomos-robot-gun-turret/17198/>
- [12] Khare. (2013, December). *Gesture Controlled Robot*. Retrieved March 5, 2014 from <http://www.final-yearproject.com/2013/12/hand-gesture-based-wireless-controlled-robot.html#.U113TfldXTs>
- [13] Neto, Pires, Moreira. (2009). *Acceleromter Controlled Robotic Arm*. Retrieved March 9, 2014 from <http://arxiv.org/ftp/arxiv/papers/1309/1309.2090.pdf>
- [14] Goyal, Saini. (2013, May). *AcceleromterBased Hand Gesture Controlled Wheelchair*. Retrieved April 1, 2014 from <http://researchtrend.net/ijet41/3%20DIKSHA%20NGF.pdf>
- [15] Edwards, Steve. (2011, February). *Microporcessors or FPGAs?: Making the Right Choice*. Curtiss-Wright Controls Embedded Computing. Referenced 3 February, 2014, from <http://www.rtcmagazine.com/articles/view/102015>

- [16] newagepublishers.com. (n.d.). *Introduction to Microcontrollers*. 1. Referenced 12 April, 2014, from <http://www.newagepublishers.com/samplechapter/001599.pdf>
- [17] Cisco. (n.d.). *Capacity coverage & Deployment Considerations for IEEE 802.11g*. Referenced 15 February, 2014, from http://www.cisco.com/en/US/products/hw/wireless/ps430/products_white_paper09186a00801d61a3.shtml
- [18] Reed, Frances. (n.d.). *How Servo Motors Work*. Jameco Electronics. Referenced 10 April, 2014, from <http://www.jameco.com/Jameco/workshop/howitworks/how-servo-motors-work.html>
- [19] IEEE. (n.d.). *Lecture 8. Stepper Motors*. IEEE. Retrieved 25 February, 2014, from http://hibp.ecse.rpi.edu/~connor/education/IEE/lectures/Lecture_8_Stepper_motors.pdf
- [20] omega.com. (n.d.). *Introduction to Stepper Motors*. Omega. Referenced 12 April, 2014, from http://www.omega.com/prodinfo/stepper_motors.html
- [21] Storr, Wayne. (n.d.). *Capacitor Characteristics*. Retrieved 3 April, 2014, from http://www.electronics-tutorials.ws/capacitor/cap_3.html
- [22] Both, Jens. (2001). *Power Saver*. BC Components. Retrieved 2 April, 2014, from <http://www.tadiranbatteries.de/pdf/applications/leakage-current-properties-of-modern-electrolytic-capacitors.pdf>
- [23] Nichicon.com. (n.d.). *General Descriptions of Aluminum Electrolytic Capacitors*. Nichicon. Retrieved 3 April, 2014, from <http://www.nmr.mgh.harvard.edu/~reese/electrolytics/tec1.pdf>
- [24] Kuphaldt, R. Tony. (2009, March). *Lessons in Electric Circuits Volume III - Semiconductors*. 3.4. pg. 108. Retrieved 7 April, 2014, from http://www.allaboutcircuits.com/vol_3/chpt_3/4.html
- [25] ecircuitcenter.com. (2005). eCircuit Center. Retrieved 26 February, 2014 from http://www.ecircuitcenter.com/Circuits/smpps_buck/smpps_buck.htm
- [26] Wikipedia. (2014, April 14). *Buck Converter*. Retrieved 15 April, 2014, from http://en.wikipedia.org/wiki/Buck_converter
- [27] Dennison, Eric. (2005). Magnet Formulas. Retrieved 10 March, 2014, from www.netdenizen.com/emagnet/
- [28] Magnet Wire/Winding Wire Product Application and Packaging Data. (1999). Retrieved 20 March, 2014 from <http://www.electro-wind.ca/suppliers-pdfs/Superior-Essex/Superior-Essex-Magnet-Wire/essex-wire-catalogue.pdf>
- [29] mistralsolutions.com. (2009, July). *Video Surveillance Bandwidth Requirements – Calculation of Utilization*. Referenced 5 April, 2014, from

<http://www.mistralsolutions.com/hs-downloads/tech-briefs/jul09-article-1.html>

[30] mustcalaculate.com. (n.d.). Retrieved 25 April, 2014, from <http://mustcalculate.com/electronics/capacitorchargeanddischarge.php?vfrom=0&vto=350&vs=450&c=.0018&r=1000&time=3>

[31] Kuphaldt, R. Tony. (2009, March). *Lessons in Electric Circuits Volume III - Semiconductors*. 7.5. pg. 329. Retrieved 7 April, 2014, from http://www.allaboutcircuits.com/vol_3/chpt_7/5.html

[32] IEEE Code of Ethics. (n.d.). Retrieved 7 March, 2014 from <http://www.ieee.org/about/corporate/governance/p7-8.html>

Appendix B – Permission Requests

Site Theory Coilguns Levitators Projects Ham Radio Sitemap

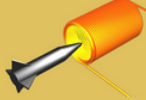
 **About This Site**

Topics: **About**

Barry's Coilgun Designs

1. Home
2. Whats New
3. Overview
4. Site Map
5. About Site
6. Bad SEO
7. Twitter
8. Disclaimers
9. Copyright
10. Privacy Policy
11. Terms of Use
12. About Barry
13. Links

Copyright

The information may be freely copied or distributed subject to the inclusion of the author's name (Barry Hansen) and the web site address (www.coilgun.info). You have permission to copy, translate, reprint, edit or reproduce this material in any form. Also note that including my site address in your materials has the benefit of allowing your readers to visit here for the latest information.

< Previous Page 9 of 13 Next >

Last update 2008-06-15
©1998-2014 By [Barry Hansen](#)



freemandonnie

Fri 4/25/2014 1:37 PM

mark as unread

To: coilgunner@yahoo.co.uk;

James Paul,

I am a student at the University of Central Florida and my senior design group chose to design a coil gun for our project. While researching the project I came across your website www.coilgun.eclipse.co.uk and have found it very informative and helpful. I would like to ask your permission to use some of your images and content for our design paper. Any content that we use from your site will be credited to you and referenced to your site.

Thank You

Donnie Freeman

Product Photos

← REPLY ← REPLY ALL → FORWARD ***



SparkFun Customer Service <cservice@sparkfun.com>
Mon 4/21/2014 9:35 AM

mark as unread

To: austin.akey <austin.akey@knights.ucf.edu>;

Hello Austin,

SparkFun product photos may be used without permission for educational purposes (research papers, school projects, etc.). Permission must be granted for commercial use and proper credit to SparkFun must be given. For inquiries about the use of our product photos or permission to use them, please contact marketing@sparkfun.com.

Please let me know if you have further questions and have a great day!

Best Regards,

Maya Kleinbort
Customer Service Representative
SparkFun Electronics
www.sparkfun.com
303.945.2984



austin.akey
Sun 4/20/2014 11:27 PM

Hello, My name is Austin and I am a Computer Engineering student at the University of Central Florida. I am currently working on the research an...

Frequently Asked Questions

What is an Arduino? Glad you asked, we have a great introduction page on Arduino, [click here to read it](#).

What do you mean by open-source hardware? Open-source hardware shares much of the principles and approach of free and open-source software. In particular, we believe that people should be able to study our hardware to understand how it works, make changes to it, and share those changes. To facilitate this, we release all of the original design files (Eagle CAD) for the Arduino hardware. These files are licensed under a Creative Commons Attribution Share-Alike license, which allows for both personal and commercial derivative works, as long as they credit Arduino and release their designs under the same license.

The Arduino software is also open-source. The source code for the Java environment is released under the GPL and the C/C++ microcontroller libraries are under the LGPL.

Breadboarding Guidelines Web Page ⤴

← REPLY ← REPLY ALL → FORWARD ⋮

 Reeder, Nicholas <nick.reeder@sinclair.edu>
Mon 4/21/2014 7:22 AM mark as unread

To: austin.akey <austin.akey@knights.ucf.edu>;

Austin:
Yes, you have my permission to use these photos.
Nick Reeder

← ← →

 austin.akey
Sun 4/20/2014 11:22 PM
Sent Items mark as unread

Hello Nick Reeder,

My name is Austin and I am a Computer Engineering major at the University of Central Florida. I am currently working on the research and documentation for my senior design project. I wanted to request your permission to use some of the photos you have posted at <http://people.sinclair.edu/nickreeder/eet1131/breadboardingTips.htm>. Also, thank you for the tips you have on that page. I found them very helpful!

Thank you,
Austin Akey

Request for permission ⤴

← REPLY ← REPLY ALL → FORWARD ⋮

 odenbrett
Sun 4/27/2014 11:56 AM mark as unread

To: spssaini.saini@gmail.com;

Hello Professor Saini,

I am a student attending the University of Central Florida, and am doing a senior design project that involves accelerometers. In 2013 you oversaw a project using this technology known as Accelerometer Based Hand Gesture Controlled Wheelchair. In this project it discusses some important features of this technology and I would like to site this in my documentation. I was requesting permission from you, any help would be greatly appreciated.

Thank you,
William Oden

Permission to reproduce



← REPLY ← REPLY ALL → FORWARD ⋮



odenbrett
Sun 4/27/2014 11:43 AM

mark as unread

To: francis.dsa@chip.in;

Hello Francis D'sa,

My name is William Oden and I attended the University of Central Florida. I am doing a senior design project that implements wireless cameras. One of the articles you wrote for Tech2 (<http://tech.firstpost.com/news-analysis/how-to-use-an-old-smartphone-or-tablet-as-a-security-camera-104346.html>) uses information that would be useful for my project. I was wondering if I could use this information in my documentation, with proper citing.

Thanks,

William Oden

Senior Design Permission



← REPLY ← REPLY ALL → FORWARD ⋮



odenbrett
Sun 4/27/2014 10:56 AM

mark as unread

To: Adam Horton;

Hello Adam,

My name is William Oden and I am currently doing a senior design project at UCF. Our project is similar to the one your group did a few years back, and as such I wanted to use one of your photos in our documentation. I was wondering if this was okay with you, if you could reply back at your earliest convenience it would be greatly appreciated.

Thanks,
William Oden

Appendix C – Matlab Codes

```
function [d_w] = wire_d(AWG)
% finds the diameter of wire in mm
d_w = .127*92^((36-AWG)/39);
```

```
function [B] = B_entry(d1,d2,I,N,x1,x2);
% Magnetic Flux Density at front of air filled coil
%  $B = ((\mu * j * l) / 2) * \ln(((r2^2 + (l/2)^2)^{.5} + r2) / ((r1^2 + (l/2)^2)^{.5} + r1))$ 
% Where  $\mu$  is permeability constant,  $j$  is current density in A/m2,
%  $l$  is length of coil,  $r1$  and  $r2$  are coil diameters
%  $\mu$  for copper is  $4 * \pi * 10^{-7}$ 
r1 = d1/2*.001;
r2 = d2/2*.001;
x1 = x1*.001;
x2 = x2*.001;
mu = 4*pi*10^-7;
num1 = sqrt(r2^2+x1^2)+r2;
den1 = sqrt(r1^2+x1^2)+r1;
num2 = sqrt(r2^2+x2^2)+r2;
den2 = sqrt(r1^2+x2^2)+r1;
ln_func1 = log(num1/den1)/log(exp(1));
ln_func2 = log(num2/den2)/log(exp(1));
B1 = ((x1*mu*I*N)/(2*(r2-r1)))*ln_func1;
B2 = ((x2*mu*I*N)/(2*(r2-r1)))*ln_func2;
B = B2 - B1;
```

```
function [B] = B_midpoint(AWG,d1,d2,I,N,l)
% Magnetic Flux Density at front of air filled coil
%  $B = ((\mu * j * l) / 2) * \ln(((r2^2 + (l/2)^2)^{.5} + r2) / ((r1^2 + (l/2)^2)^{.5} + r1))$ 
% Where  $\mu$  is permeability constant,  $j$  is current density in A/m2,
%  $l$  is length of coil,  $r1$  and  $r2$  are coil diameters
%  $\mu$  for copper is  $4 * \pi * 10^{-7}$ 
d_w = wire_d(AWG);
r1 = d1/2*.001;
r2 = d2/2*.001;
l = l*.001;
mu = 4*pi*10^-7;
A = N*pi*(d_w/2*.001)^2;
j = I/A;
num = sqrt(r2^2+(l/2)^2)+r2;
den = sqrt(r1^2+(l/2)^2)+r1;
ln_func = log(num/den)/log(exp(1));
B = (mu*j*l)/2*ln_func;
```

```
function [S,S_20,shots] = Onderdonk(AWG,I,deg)
% The Onderdonk Equation for wire sizes used in fuses
%  $33 * (I/A)^2 * S = \log((T_m - T_a) / (234 + T_a) + 1)$ 
% Where  $I$  is the current in Amperes,  $A$  is the area of wire in circular
% mils,  $S$  is the time the current flows in seconds,  $T_m$  is the melting
% point in degrees C (1084 C for a copper conductor),  $T_a$  is the ambient
% temp in degrees C (room temp will be assumed for calculations)
```

```

Tm = 1084;
Ta = (deg-32)*5/9;
A = (5*92^((36-AWG)/39))^2;
S = (A/I)^2*log10((Tm - Ta)/(234 + Ta) + 1 )/33;
S_20 = S*.8;
shots = S_20/.002;

```

```

function [L] = inductance(AWG,d1,d2,l)
% Inductance equation for air core solenoid
% L = .8(NA)^2/(6A+9B+10C)
% N is # of turns, A is avg coil radius, B is coil length,
% C is coil thickness
% function takes inputs for conductor size, inner and outer
% radius and coil length
r1 = d1/2;
r2 = d2/2;
d_w = wire_d(AWG);
N_per_layer = floor(l/d_w);
layers = floor((r2-r1)/d_w);
N = N_per_layer*layers;
B = N_per_layer*d_w*.039;
A = ((r2-r1)/2 + r1)*.039;
C = (d2-d1)*.039;
L = (0.8*(N*A)^2)/(6*A + 9*B + 10*C)*10^-3;
% Resistance equation for copper conductor
% R_c = (16*F*rho(r2^2-r1^2)*l)/(pi*d_w^4)
% F is the coil filling factor, rho is wire resistivity,
% r1 is inner diameter, r2 is outer diameter, d_w is
% the diameter of the wire
F = pi/4;
rho = 1.68*10^-8;           % for copper
n = 0;
c = 0;
l_wire = 0;
while n ~= layers;
    r_layer = ((r1 + d_w/2) + n*d_w)*.001;
    c = 2*pi*r_layer;
    l_layer = c*N_per_layer;
    l_wire = (l_wire + l_layer);
    n = n + 1;
end
l_wire
A = pi*(d_w/2*.001)^2;
R_wire = (rho*l_wire)/A

```