

University of Central Florida

Department of Electrical & Computer
Engineering

EEL 4914
Senior Design



QwikCam

Divide and Conquer v2.0

Design Project

Author:

Mark Escott, EE
Steven Little, CpE
Kevin Brown, EE
Santiago Alvarez, CpE

Instructor:

Professor Richie

Project Sponsor:

Todd DeNoyer, Qwikcut Video & Analytics

January 21, 2021

Topic - Project Narrative

In the United States alone there are over 25,000 high school and junior programs. Extracurricular activities such as school sponsored sports and athletics make up a significant experience to millions of students and their families every year. Whether it be through direct contact and participation of an individual or the commitment of the family to come and support those that are participating. Being able to record, stream, and access footage of these athletics are crucial to many different clients and personnel in the junior athletic world. This can range from family members out of state wanting to tune in for a Friday night football game of their family member to a coach wanting to record the play on a soccer pitch to show his players later on in practice sessions what can be approved upon.

Qwikcut is a video and analytics company based in the central Florida area that is contracted to go to high school athletics such as Football games, Soccer matches, lacrosse matches, etc and their objective is to record, stream, and relay these games in real time from their current camera and tripod setup. This recording and live streaming can be used for some of the examples listed in the above sections and gives the customer a great service in filming these events. The Qwikcut current setup coincides with a 25' tall tripod that is mounted with a Bescor motorized head with a Sony handycam and three cables used for streaming.

However, over the years that Qwikcut has been operating they have found their tripod and camera setup to be less than adequate to handle the needs of the company and have been running into some issues that need to be addressed. The current setup as listed above has problems with its three cables system in which these cables are always needing to be replaced which is a great expense, the motorized head that is used at the top of tripod does not pan fast enough for sports and uses 4- AA batteries as a power unit, and the HDMI that is currently used does not carry audio while streaming the video. Along with these design issues another big issue comes from the fact that Florida's weather does not always give the company perfect conditions to film in, especially when the current equipment is not waterproof. In order to solve these downfalls Qwikcut has called upon us to improve upon their current setup and design a new filming tripod that they call the Qwikcam.

Qwikcam will improve upon all aspects of the previous design in that it will feature more adequate and updated technology that can be used to better serve Qwikcut themselves but also their customers. The system will comprise of a Pan-Tilt-Zoom (PTZ) camera that will be housed in a waterproof container that will run via either a singular USB 3 or CAT 5 cable that will run to a computer to be recorded and streamed in real time. This PTZ camera will be able to stream in at least 1920x1080 clarity and will be able to be controlled by a wired game controller connected to the computer.

The goal for our customer is to create a portable, lightweight, and overall simple system that can be taken to a wide variety of schools, athletic events, and locations around the central Florida area and be used by the Qwikcut team in order to make their recording and streaming of games as efficient and easy as possible.

Motivation

There are many things we can look at while watching game film that can be very useful for both the student and the coach. These films are meant to be a very important part of moving from the highschool level to the collegiate level in many cases. In the quest of trying to reach that level, it's well known that using game film lets you become your own coach in a way and see things that may be too hard to explain. It provides players a means of reflection with an opportunity to notice the other teams or their own strengths and weaknesses. When players can see first hand and recognize a role they can improve on, they become much harder to overcome.

In our group, we have either seen, shot, or edited a game film at some point in time and we see there are things that can be improved on as well as problems that need to be fixed. We feel like the issues Qwikcut has expressed to us, when fixed, can make the world of a difference in the eyes of a student trying to up their game, a coach or even a prospect trying to get more information which can then turn this into a make or break moment.

As a group it was exciting to think of the improvements we can make along with how this idea can be brought to the next level of convenience, with streaming being a large portion of media consumed today, we are streaming more than ever. This is due to the newer forms of entertainment being brought about and with an even bigger obstacle we face every day now with COVID-19. Living with the virus today has made most of us uncertain with how big groups will gather in the future and streaming has been a big part of that.

With all these factors in mind, we felt like this was a project that was perfect for our group to tackle. We feel that we can take the needs and requirements from Qwikcut and deliver on something all parties can be proud of at the end of the day. Below we can also see the setup that Qwikcut is working with so we can get an idea of devices and requirements we must use to make this project a reality.





Requirements Specifications

Going off the previous build and tripod for Qwikcut the new and improved qwikcam will need to be able to meet the specifications of our sponsor. This project will fulfill the following requirements:

- Use a Pan-Tilt-Zoom (PTZ) camera that PoE (Power over Ethernet) capable
- Would need to be easily mounted to the current 25' tripods that Qwikcut uses
- Use only 1 cable to run down to a laptop, possibly USB 3 or CAT 5
- PTZ camera would need to be able to be run by a game controller connected to the computer
- Video needs to be stored on either an SD card in the computer or internal hard drive or both
- This system/build will need to be waterproof as well

Possible extra requirements or alterations we could add:

- Wireless communications system from the computer to the camera, no wired connection
- Motorized system to build onto tripod to lift the system into the air up to the 25' requirement
- Possibly multiple cameras around to be switched to remotely.

		Panning Speed	Quality of Video	Battery Life	Weight	Target
		+	+	+	-	
Panning Speed	+		↓	↓	↓	Full Field In 10 seconds
Quality of Video	+	↓		↓↓	↓↓	1080P
Battery Life	+	↓	↓↓		↓↓	10-12 Hours
Weight	-	↓	↓↓	↓↓		=< Existing

Table 1: House of Quality

Constraints:

Below is a list of constraints that are outlined in the project description given by Qwikcut.

<u>Part Required</u>	<u>Specification and Type</u>
Tripod	<ul style="list-style-type: none"> • At least 20' Tall
Camera	<ul style="list-style-type: none"> • Capable of 1920x1080 quality or higher • 180 pan angle • 90 degree tilt angle • Zoom capability of at least 20 yards • PoE powered • Waterproof - Preferably IP66 waterproofing • Programmable
FPGA/Microcontroller	<ul style="list-style-type: none"> • Wireless communication
Computer	<ul style="list-style-type: none"> • Qwikcut sponsor use of a new laptop. • Needs to have at least a 4 hour battery life
Controller	<ul style="list-style-type: none"> • Wired, 360 degree motion control
Microphone	<ul style="list-style-type: none"> • PoE powered, range of at least 50 yards
Qwikbox	<ul style="list-style-type: none"> • Waterproof container for limited storage
SD Card	<ul style="list-style-type: none"> • At least 64 GB
Network	<ul style="list-style-type: none"> • Verizon wireless network @ 15GB

Table 2: Project constraints

Block Diagram

This section will divide portions of our project into respective sections that will be researched and looked into by our group members. Currently every section is in the research phase of the project.

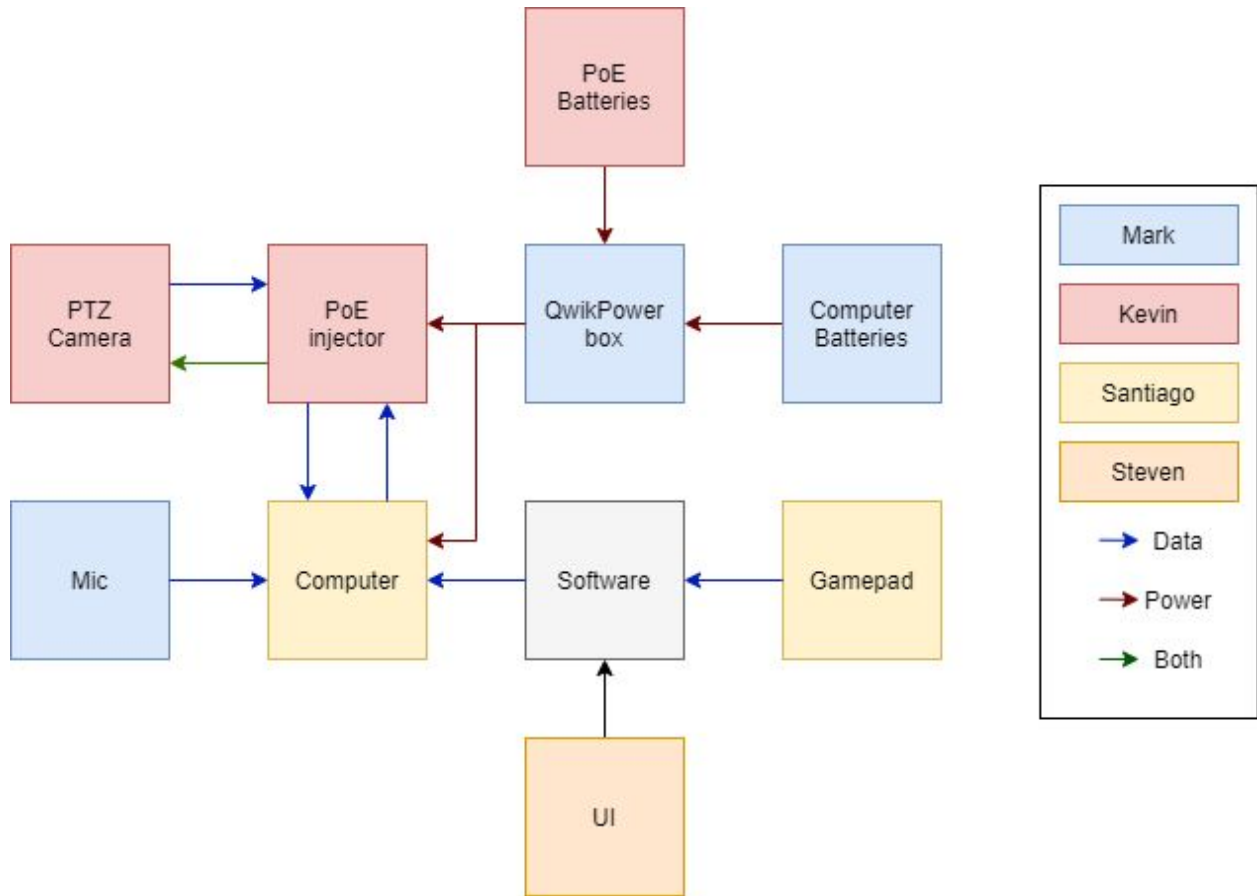

Figure 1: Block Diagram

Budget and Financing

The table listed below lists all needed parts and aspects of this project at the moment with a minor description of the part along with a price. Quantity and suppliers are also listed but will need to be altered and added to as the semester and project moves on as there are a few aspects of the project and design still up in the air. A more definitive price and overall quantity will be determined at a future date. Some parts and pieces will be provided by our sponsor at Qwikcut and most if not all parts and supplies needed for this project are to be purchased or funded from our sponsor. This is unless any unforeseen circumstances or equipment issues may arise down the line. Much of our projected budget and cost for this overall project are yet to be decided based on which project will serve Qwikcut and our design build the best. So the total cost of the project is still up in the air. Please refer to table 3 below for more information.

<u>Part</u>	<u>Part Description</u>	<u>Quantity</u>	<u>Price (\$USD)</u>	<u>Supplier</u>
Housing unit	Waterproof containment apparatus	1	30-70	TBD
PTZ Camera	Camera to be used in the filming	1	200-300	TBD
Tripod	Tripod the system needs to be mounted upon	1	0	Qwikcut
Game controller	Controller to control the movement of the PTZ camera	1	30-50	TBD
Cable	CAT 5e cable to be connected to the computer and the camera	10m	5-15	TBD
Batteries - POE	External batteries to power PCB board or PTZ camera	1-4	10-20	TBD
Batteries - Computer	Batteries to operate the laptop - Minimum 4 hour life	1-3	100-150	TBD
Computer	Laptop to operate and control the camera from	1	300-600	TBDt
Poe Injector	Injects power into a ethernet cable	1	15-25	TBD
Microphone	Used to pick up audio along with the PTZ camera	1	20-40	TBD
SD Card	SD card to download and store the video from the PTZ camera	1-2	10-12	TBD
		<u>Total Price:</u>	860-1,342	

Table 3: Budgeting and finance

Project Milestone

This section will detail and lay out the basic groundwork for how our group is going to research, prototype, and build our final project at the end of the summer 21 semester.

<u>Objective</u>	<u>Semester</u>	<u>Start date</u>	<u>End Date</u>	<u>Status</u>
Senior design idea generation	Spring 21	1/11/21	1/18/21	Completed
Confirmation of project	Spring 21	1/19/21	1/22/21	Completed
D&C V1	Spring 21	1/23/21	1/27/21	Completed
Meeting with professor Richie	Spring 21	2/2/21	2/2/21	Completed
D&C V2	Spring 21	2/3/12	2/12/21	In Progress
Respective research for all 4 members	Spring 21	2/13/21	3/19/21	In Progress
60 Page Draft	Spring 21	3/19/21	4/2/21	In Progress
100 Page Draft	Spring 21	4/3/21	4/16/21	In Progress
120 Page- Final Documentation	Spring 21	4/17/21	4/27/21	In Progress
Final meeting with sponsor to confirm ideas before building	Summer 21	4/29/21	4/29/21	Has not occurred yet
Order components	Summer 21	TBD	TBD	
Initial building and testing	Summer 21	TBD	TBD	
Build Prototype	Summer 21	TBD	TBD	
Test and Debug	Summer 21	TBD	TBD	
Redesign if needed	Summer 21	TBD	TBD	
Final Documentation senior design 2	Summer 21	TBD	TBD	
Finalize project	Summer 21	TBD	TBD	

Table 4: Milestones

Research

-PoE system

We will be using a PoE system as our main way of powering the devices for our Qwikcam design. PoE is a medium for carrying electric power over traditional data cables (CAT cables). With the PoE specified devices, we are passing a current through the ethernet cable along with the data that is also carried over by ethernet cable. These power over ethernet devices supply power according to the IEEE 802.3 device generation. The generation is indicated by the suffix “af”, “at”, and “bt”. These can also be more basically seen as PoE, PoE+ and UPoE. These PoE standards offer a larger power budget per device on the network, delivering from approximately 15.4 watts, 30.8 watts, and 60 watts respectively.

Network cables, or our ethernet cables, like our Cat 5e and Cat6, are made of eight wires grouped as four twisted pairs. Two of these pairs are used for sending information, which are known as the data pairs. Leaving the other two pairs unused and they are referred to as the spare pairs. We know that electrical current flows in a loop, so we need at least two conductors to carry our electric current. This is obtained by the PoE treating each pair as a single conductor, so it will utilize either the two spare pairs or even the two data pairs to carry that current. When power over ethernet is injected onto the cable at a voltage between 44 and 57 volts DC, the standard practice and what is typically used is 48 volts. This voltage may seem high but it allows for more efficient means of transferring power from endpoint to endpoint. This voltage is also still at a low enough level to be considered safe. Under normal circumstances with dry skin the 48 voltage may give a shock and wake you but is rarely enough to be lethal. Before our PSE or our power sourcing equipment can enable power to our desired PD or powered device, in this case will be our pan tilt zoom camera, it must perform a signature detection process. When this process takes place, our PSE uses a lower voltage to detect the characteristics signature of IEEE compatible powered devices mentioned previously. When this signature has been detected, the PSE knows that higher voltages can be safely applied by detecting the resistances as seen on table 5. We can see a more in depth depiction of the powering stages for PoE devices.

Stage	Action	Volts (IEEE standard)	
		802.3af	802.3at
Detection	PSE detects if the PD has correct signature resistance of 19-26.5kohm	2.7-10.1	
Classification	PSE detects resistor indicating power range	14.5-20.5	
Mark 1	Signals PSE is 802.3at capable. PD presents a 0.25-4mA load.	-	7-10
Class 2	PSE outputs classification voltage gain to indicate 802.3at capability	-	14.5-20.5
Mark 2	Signals PSE is 802.3at capable. PD presents a 0.25-4mA load.	-	7-10
Startup	Startup Voltage	>42	>42
Normal operation	Supply power to device	37-57	42.5-57

Table 5: PoE startup

Any device that can utilize a PoE connection through an ethernet cable, only needs one cable connection for power and data. This can make our design much more clean and simpler, which is a main goal of the Qwikcut sponsor. Having a power over ethernet connection also holds the benefit of being less expensive and easier to maintain. Rather than using a power and a data connection

separate like the existing setup, the power over ethernet design offers more reliability and safety. Having multiple power cords often in its existing form makes the system cluttered and oftentimes more prone to breaking. Having a lower number of devices allows us to use a device called a PoE injector. These are smaller devices that receive an external power source which will reside between the computing device or the device providing power via PoE and the endpoint device to be powered. Using injectors for a larger system can be very cumbersome and complicated almost eliminating the reason for the PoE system in the first place.

While there are some limitations of some power over ethernet systems, they have been taken into account and they include transmission distance, device compatibility, and power delivery rates. Our design is meant to be smaller than a typical PoE camera system and will only need a transmission distance of less than 50 feet. This is well under the maximum transmission distances of around 100 meters and we are making sure the camera is power over ethernet compatible so it may be a more user friendly system for our sponsor and it also meets the sponsors needs of using a Pan-Tilt-Zoom camera.

-Controlling software

We will be developing a custom piece of software that will control the PTZ camera via a gamepad controller. This software will be written in Java utilizing Swing and JInput packages to achieve the user interface and controller input respectively. The goals for the software is as follows, to have a friendly user interface, to allow for any USB based gamepad to work, and to allow for smooth operations of the camera. The software will not be responsible for actually recording or streaming the video from the camera as pre-existing and well documented software already exists.

As this software might ship to customers it must be written such that almost any modern computer can run it. To achieve this the program will be multithreaded to allow for the user interface, controller input, and networking to never have to wait on each other. There will also be a heavy focus on making sure the code is optimized and stable over long periods of time. Luckily Java has a lot of built in tools to help us achieve these goals.

To control the camera the software must utilize the ONVIF standard that most modern IP cameras utilize to specify motion and camera control. More research is needed to choose if a custom implementation is needed or if a pre existing package will be able to perform the actions needed. This implementation will run on a separate thread such that inputs can be continually scanned as motion signals get sent.

The controller element using JInput will allow for the user to select which controller to use, to set up dead zones and which joystick controls what motion. JInput has grouped controllers by type, for our software to be as flexible as possible with controllers we must code for all types that have analog sticks as they will allow for the smooth camera control needed.