Group 16

Mark Escott
Steven Little
Kevin Brown
Santiago Alvarez

Sponsor:
Todd DeNoyer



QwikCut

VIDEO & ANALYTICS

Senior Design 2 : Critical Design Review



Steven Little
Computer Engineering



Santiago Alvarez
Computer Engineering



Kevin Brown
Electrical Engineering



Mark Escott
Electrical Engineering

Motivation

- The motivation for our project is to design and build a new and improved camera and recording system for our sponsor QwikCut to use for their business practice.
- We are trying to design a system that has the ability to be cost effective and efficient enough in its quality to have the possibility of the design being built on a larger scale.



Goals and Objectives

<u>Goal</u>	<u>Objective</u>
<ul style="list-style-type: none">• The new design to be a less cluttered PoE system with a single cord leading to the camera• Fast panning head on a PTZ camera• Streaming using hotspot provided and storage capabilities for film• HD quality for camera	<ul style="list-style-type: none">• To create a setup for QwikCut that can be used to film various sports games while streaming and recording of game film where there is no press box.

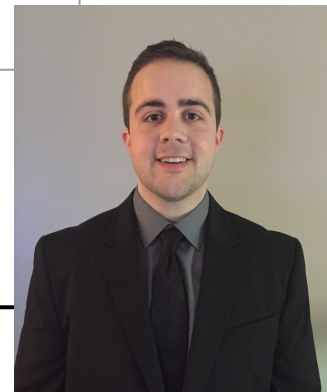

Existing System

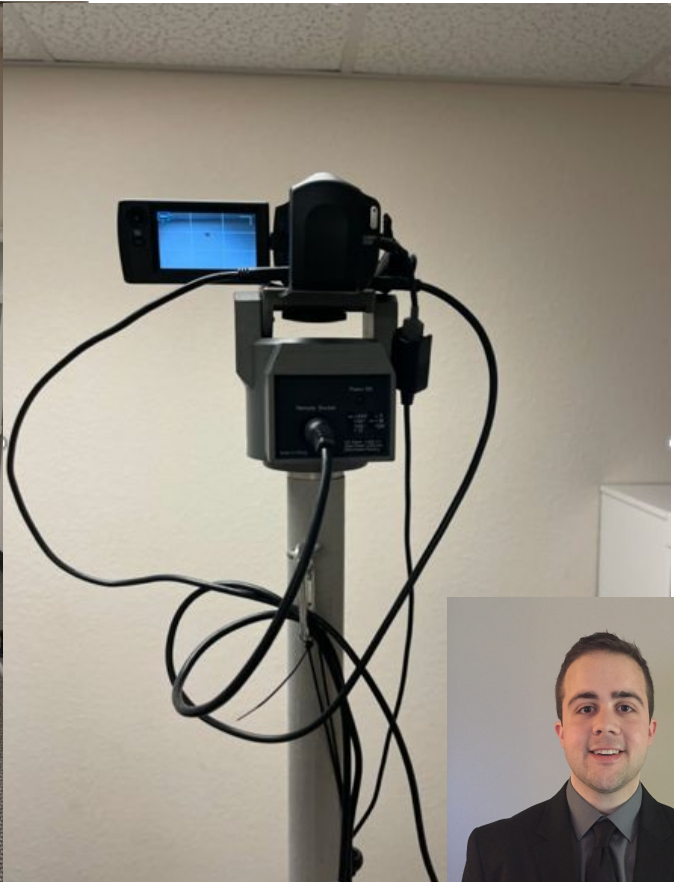



Specifications and Requirements

<u>Device</u>	<u>Constraint</u>	<u>Value</u>
Batteries	Runtime, Storage	<ul style="list-style-type: none">● 10-12 hours
Camera	Quality/Definition, PTZ capabilities, Waterproof	<ul style="list-style-type: none">● Minimum of 1080p HD● IP66 waterproofing● 0-90° Tilt● 0-180° Minimum Pan● 10x Zoom minimum
PCB	Portability, Functionality	<ul style="list-style-type: none">● Ability to fit inside our existing storage box● Must be able to provide IEEE 802.3 af/at capabilities
Software	Ease of use, Features	<ul style="list-style-type: none">● Needs to be easy to use● Able to control the camera

Block Diagram Progression - Software

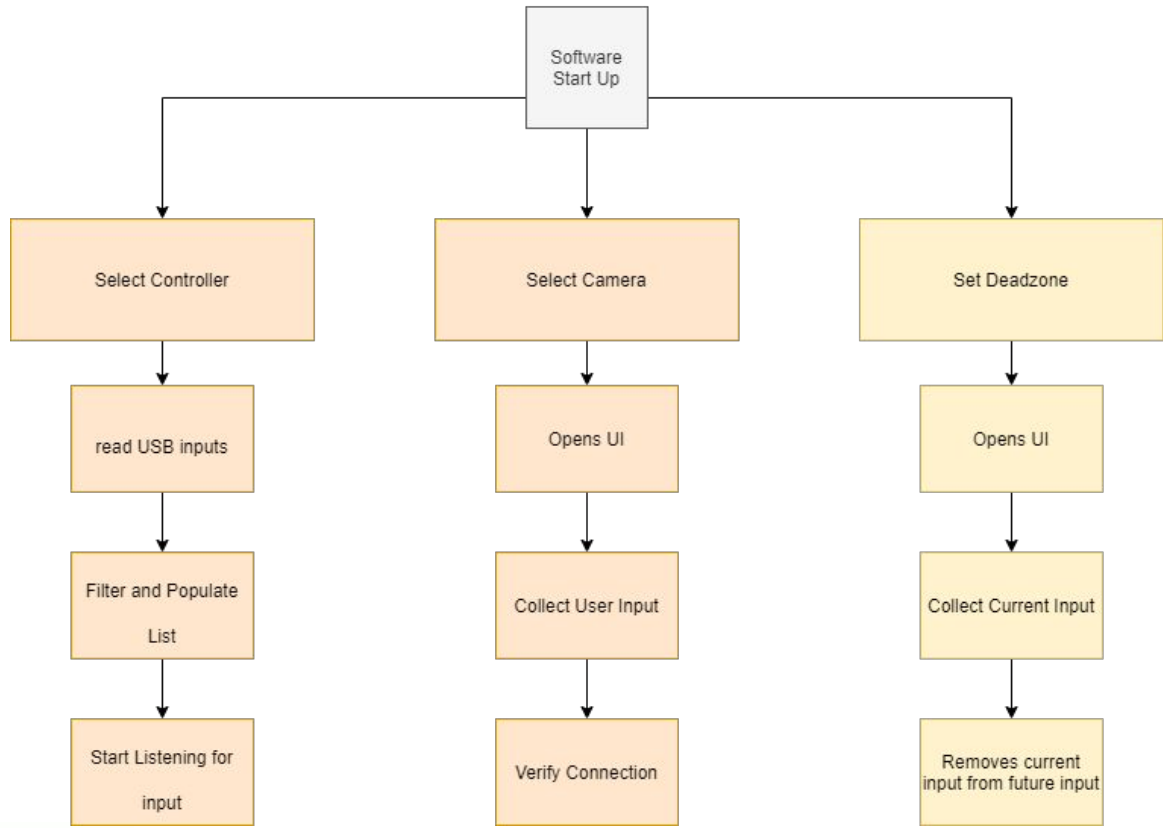

Mark
Kevin
Santiago
Steven
→ Data
→ Power
→ Both



Software features

- Easy to use and setup
- Be capable of running on most modern computers
- Be able to identify compatible cameras on the network
- Self contained and portable
- Allow the user to adjust how the inputs are scaled and mapped



Software - Technologies used

Java - used for its ability to run on most platforms.

ONVIF - used to allow for the software to talk to and control the camera. Open industry standard.

Jinput - used to read a gamepad controller. Widely used and documented.

Swing - used to make the UI. Prior experience and ease of use.



Software UI



The user interface for this software is designed to be minimal.

No video preview or processing is performed via the software.

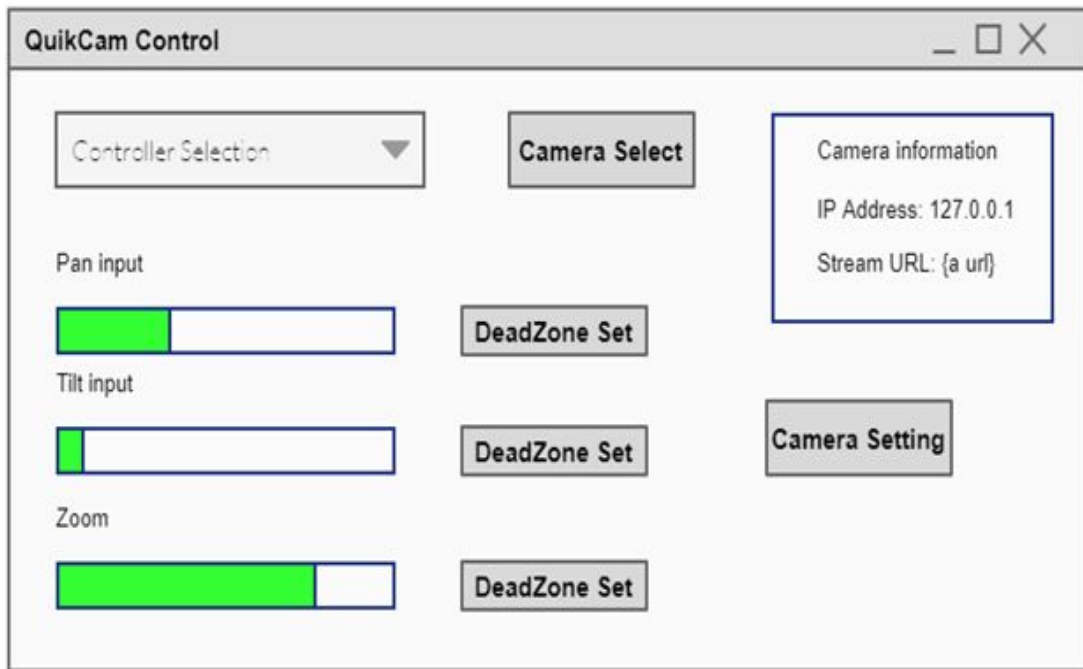



Software - Completion Percentage

- Overall Software completion

Software Component	Completion Percentage	Testing Needed?
UI	80% (Basic functions are done may need expanding)	Yes - Check for functionality
Camera Interface	70% (Can talk and move a camera needs fine tuning)	Yes - Test multiple cameras
Controller Interface	70% (Basic movement is done need to add and test more advanced features)	Yes - Test more controllers - Test dead zones and nonlinearity
Integration	25% (Need to add and test all components)	Yes - Verify all individual components work together

Laptop



Acer Aspire 5

\$523

8GB RAM

128GB SSD

Ryzen 3200u 3.5GhZ



Block Diagram Progression - Hardware

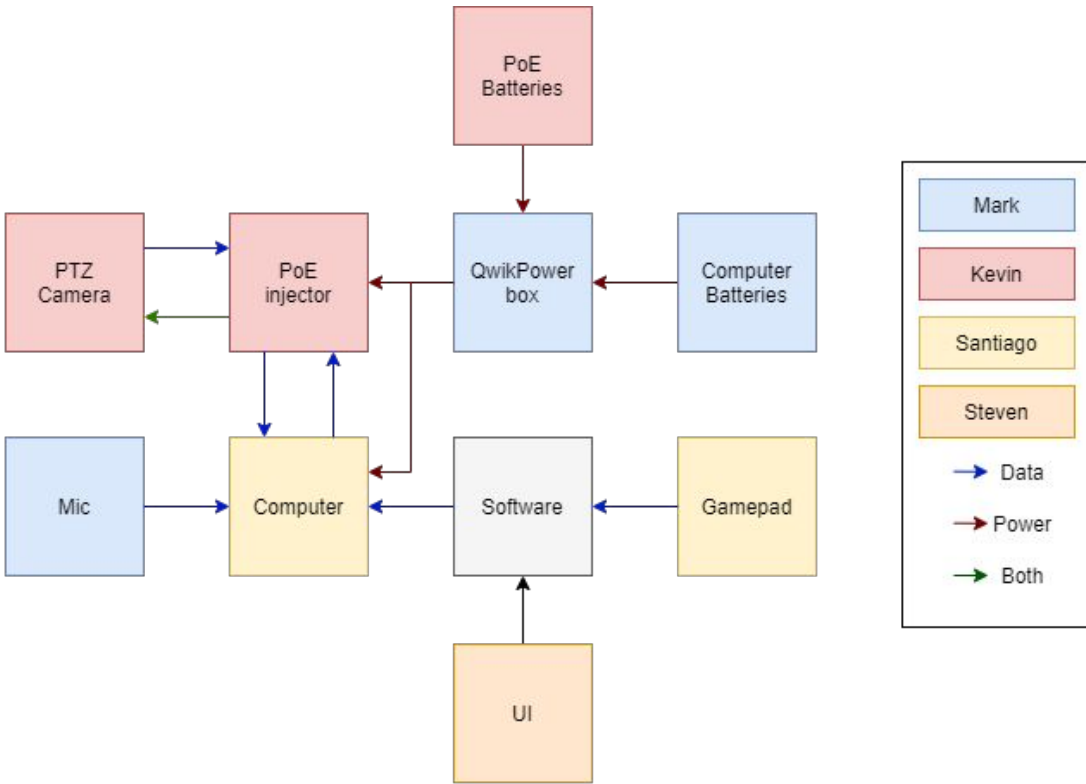

PoE Implementation

- Purpose: Used to provide power to camera and receive data via ethernet cables.
- Helps simplify the system and requires less cabling

- Defined by IEEE 802.3af and 802.3at standards
- PoE can check if the connected device requires power and if this check passes, the PoE device whether it be an injector, switch, or hub, sends the power to the connected device



- The most crucial hardware pieces in the design consist of the following parts:
 - PTZ (Pan-Tilt-Zoom) Camera
 - A Printed Circuit Board POE Injector
 - Portable Batteries to power the PCB and Laptop
 - Laptop to record and stream the information provided from the camera system



Hardware - Camera Options/Designs

- After considering multiple design choices and the possibility of designing our own PTZ camera we decided that the most logical choice and design for our system would be to repurpose an already existing camera on the market and retrofit the camera into our QwikCam design.
- Many different units and designs were considered and presented to our sponsor covering many different specifications and details. Each product was discussed with the pros and cons for each unit and our input on what camera option we think should be incorporated in the overall design
- Price range categories ranged from \$500+, \$500-300, and below \$300



Hardware - Final Camera Selection and Specifications

- After the careful deliberation and considerations for the multiple camera designs we have chosen the **Alptop 4K Outdoor POE PTZ Camera**
 - This camera company and design is readily available on amazon and other online retailers.
 - At a price point of \$330 dollars it fits into the mid range of our price categories and a very good quality camera for the price.
 - With its built in POE capabilities it is capable of being powered and transferring data via a singular Cat 5e or above cable simplifying the connections and overall process for our sponsor.
 - Meets all of the required specifications in regards to Quality, PTZ movement, and Waterproofing.



Hardware - Camera Mount



- The camera mount is a critical part of the QwikCam system, as it allows for the adoption of an existing tripod to a new camera system.
- Custom design that should be easy to attach, store, and transport.
- As we have not been hands on with the tripod the design is not finalized or prototyped.

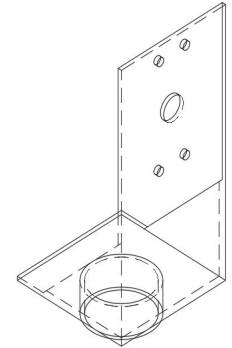
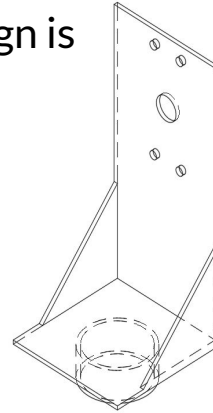

Hardware - PCB Injector

- A portable POE PCB injector will accomplish the goal of powering our PTZ camera remotely while keeping the design in a compact form and power efficient for an extended period of time.
- After doing some research on POE design requirements and capabilities we were able to find some Texas Instruments products and designs that could be used and sourced into our project in order to make sure we can successfully power any POE device that we may use.
- Our PCB Injector can be broken down into a few main sections when building as seen in the flowchart.

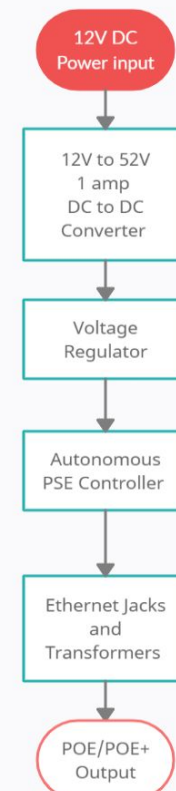

Hardware - PCB Design: DC to DC Converter

- 12V to 52V, 1 Amp DC to DC Converter
 - The Converter includes the following components:
 - Input/Power jack
 - LM5022 6-60V Boost Controller

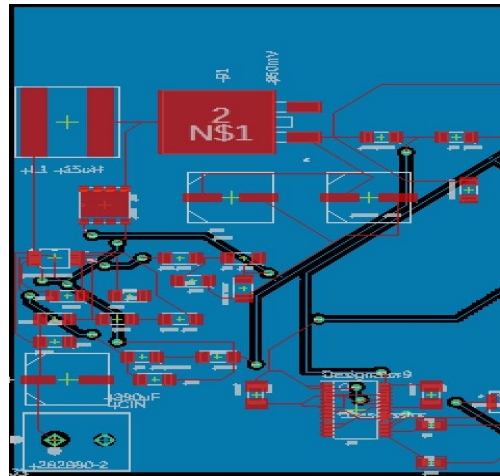
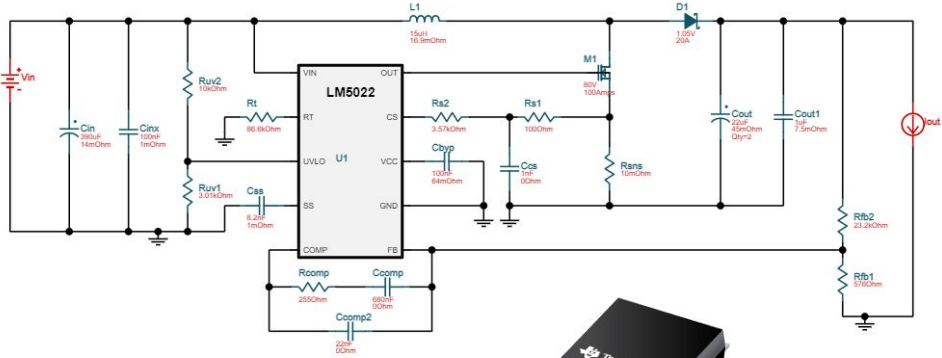
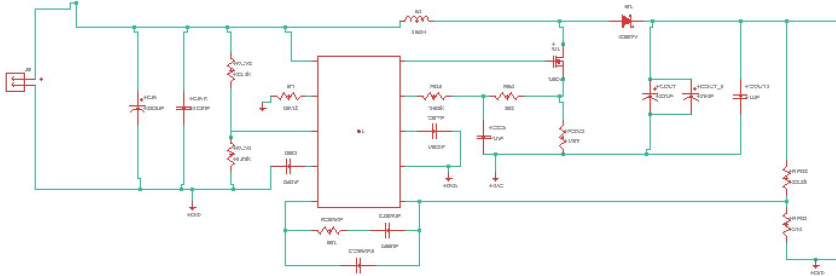

Hardware - PCB Injector - Voltage Regulator

- This section of the PCB Consists of:
 - TPS7A4001 Voltage Regulator
- The TPS7A4001 is used to power the autonomous PSE controller in the next section of the board. Converts the 52V DC back down to a digital 3.3V.

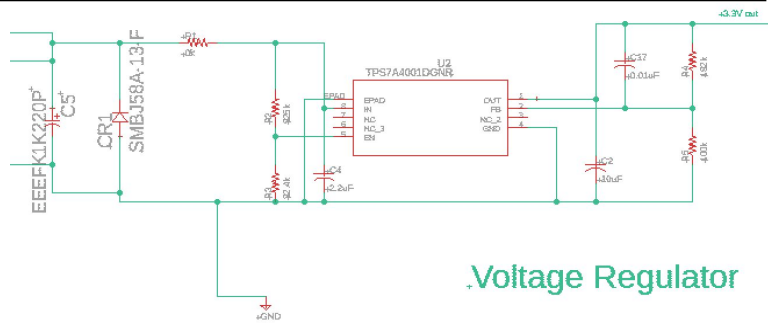

.Voltage Regulator

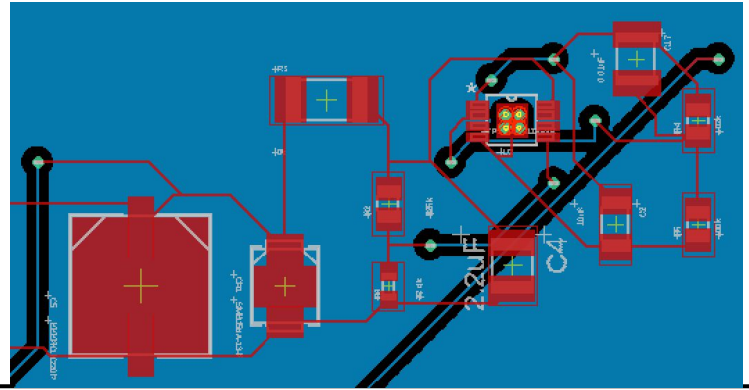
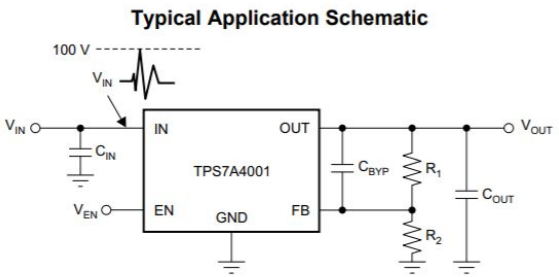

Hardware - PCB Injector - Ethernet Jacks and Transformers

- This section of the PCB consists of:
 - RJ45 Ethernet Jacks
 - Ethernet magnetics
 - Transformers 1000BASE-T compliant

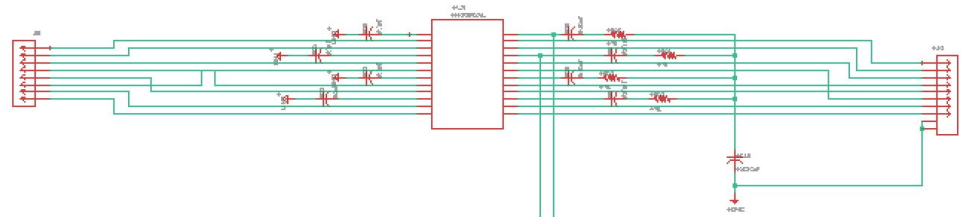
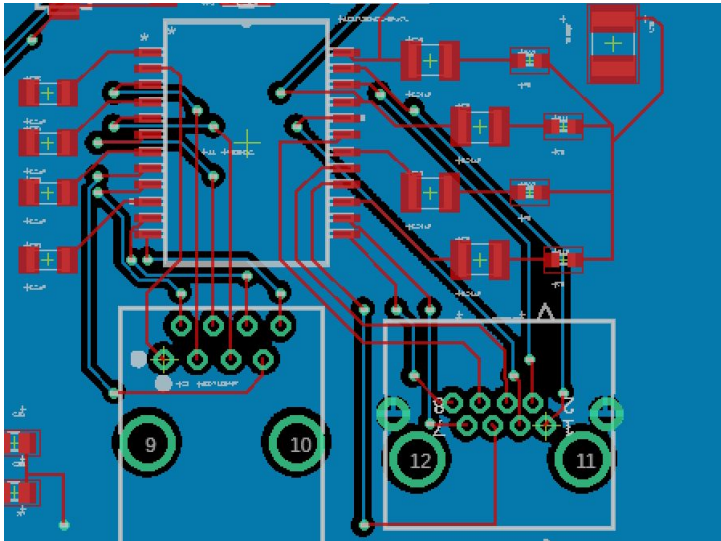

Hardware - PCB Injector - Overall Board

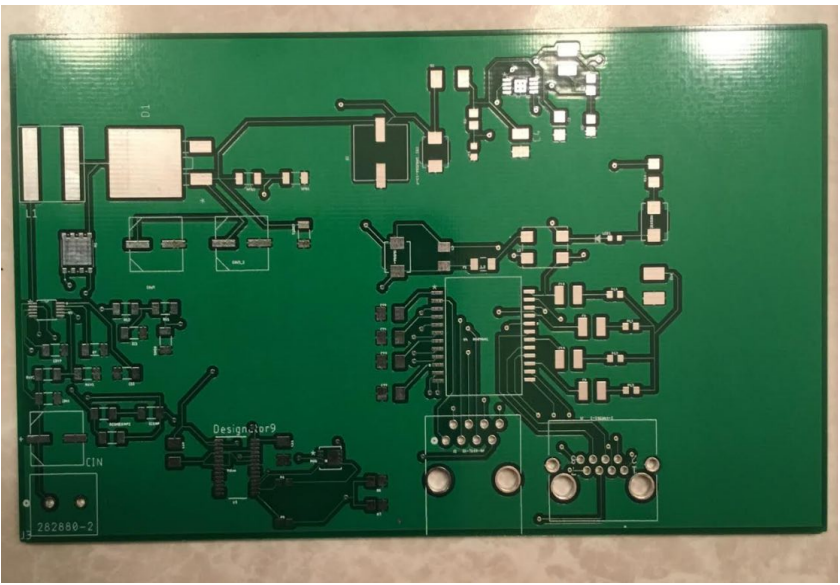
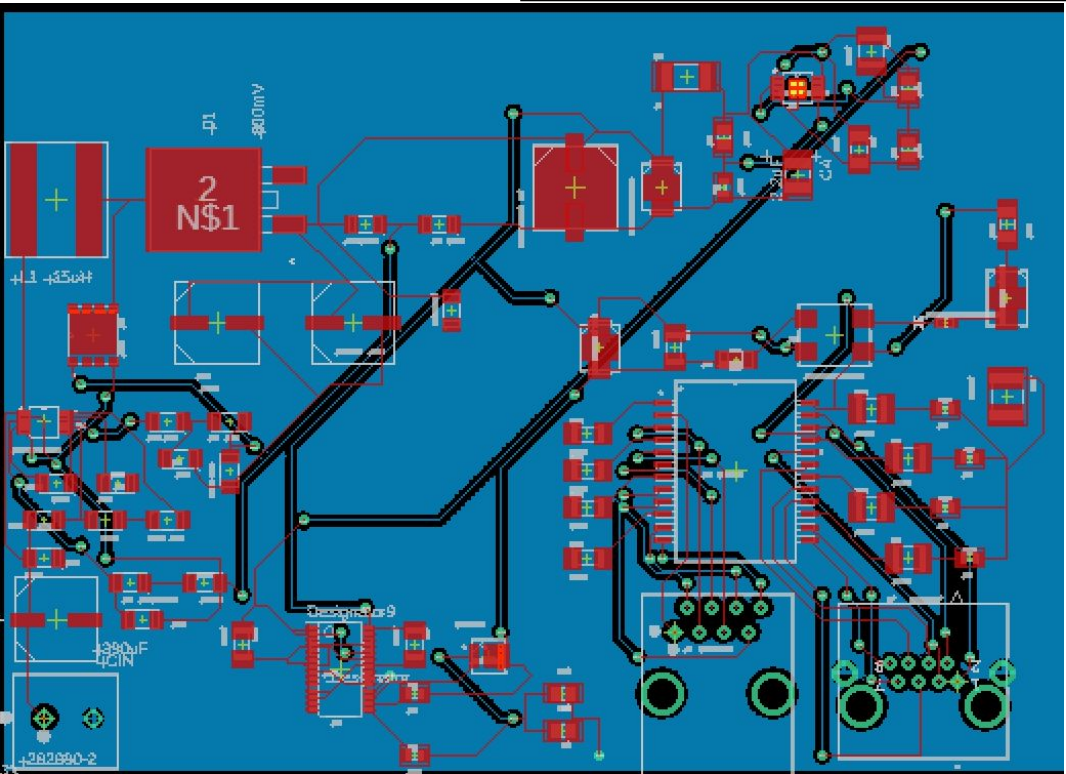

Power System Design

Requirements:

- Portable water resistant storage
- Laptop for live recording and streaming
- Single cord to the camera unlike existing system that has 3, making it more cluttered than desired.

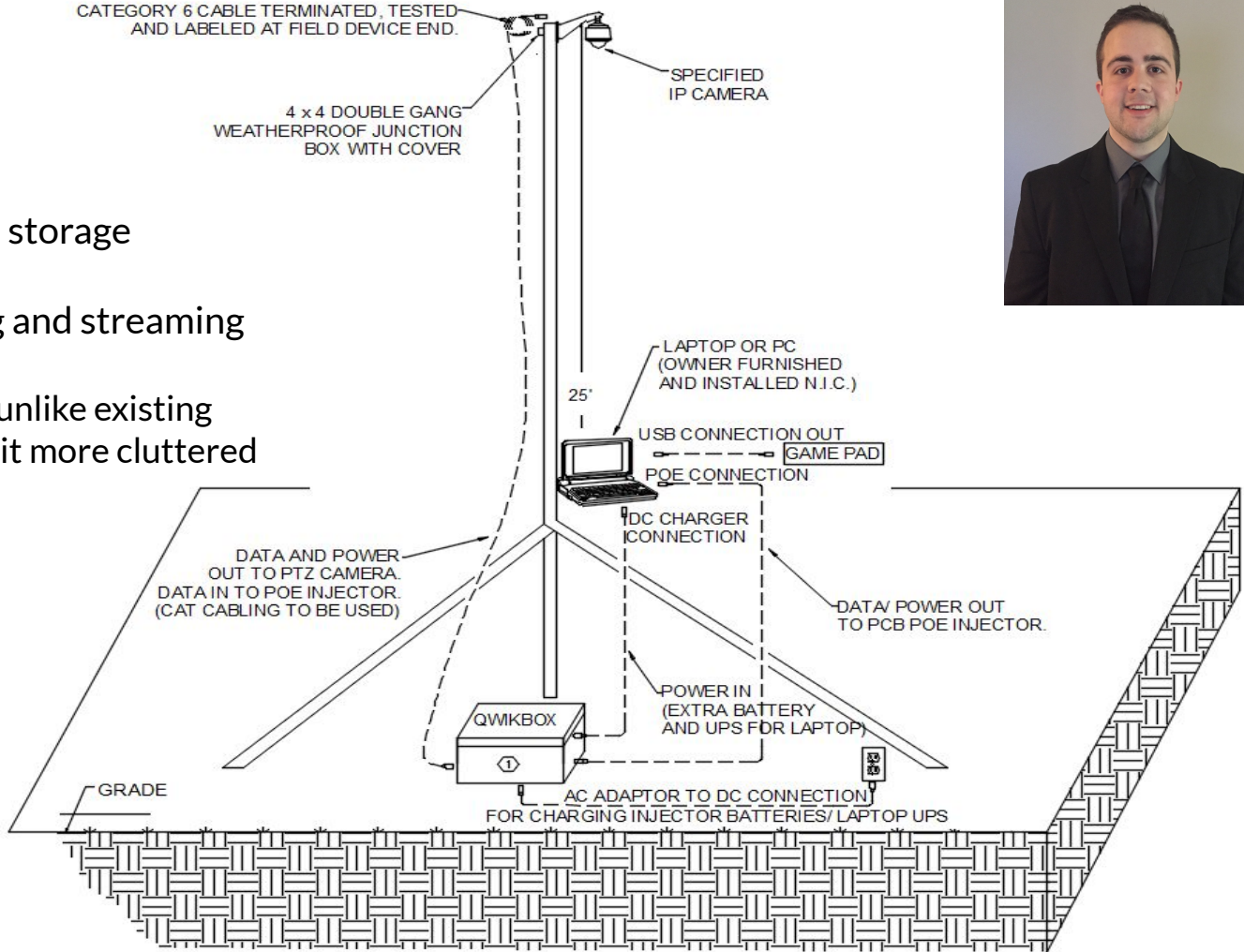
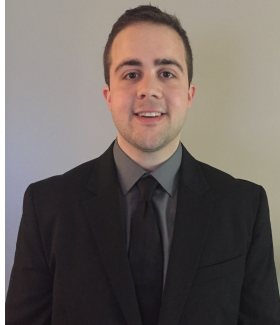

Hardware - Power flow

Power inside Qwikbox:

- Injector battery bank lasting 10-12 hours max for long days
- Extra laptop battery to charge laptop for any additional time needed
- DC connection to PCB injector and for charging of battery bank
- DC connection for laptop battery to charge

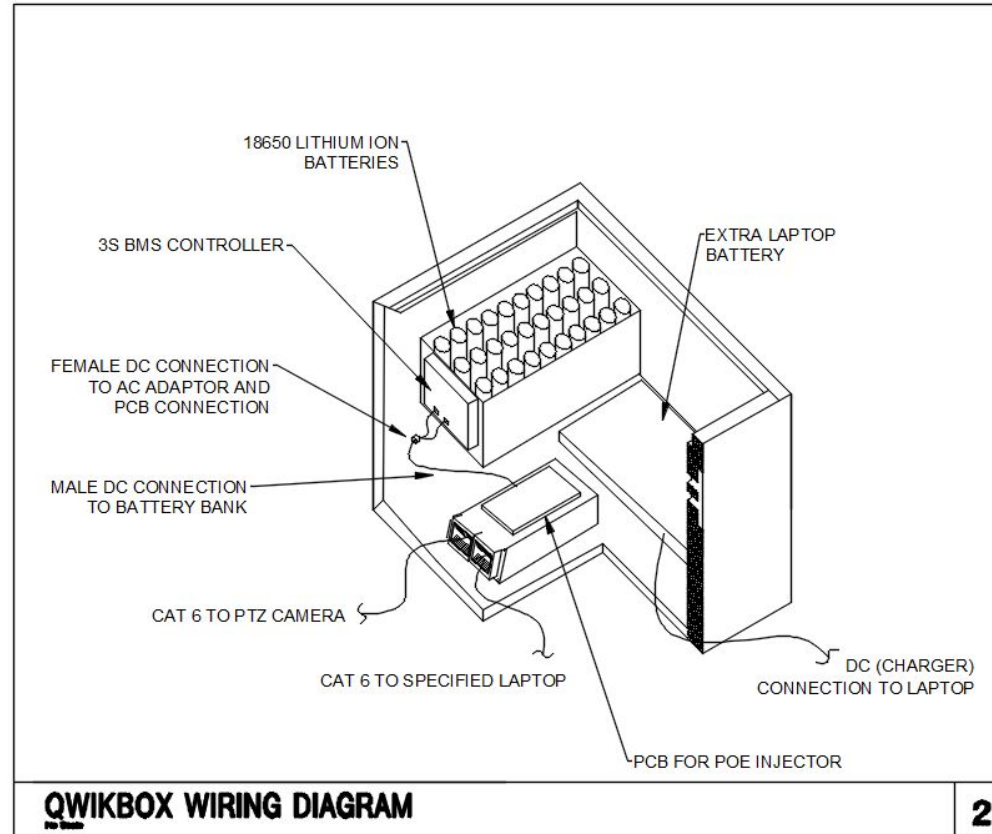

Hardware - Component Decisions

- 30 x 18650 batteries
- A 3S 25A BMS Board that manages the lithium ion battery pack.
- Ni Strips for connection of the batteries in series and parallel.
- DC jack.
- Holder for the 18650 batteries.



Hardware - 18650 Batteries

- 18650 lithium Ion Cells (3400mAh at 3.7V) chosen for the Storage and powering of the Injector.
- Will be used in series and parallel to create a chargeable battery pack with Li-ion BMS board to help with protection.
- Provide best discharge curve and allow a good size to storage ratio.

NCR18650B
PANASONIC

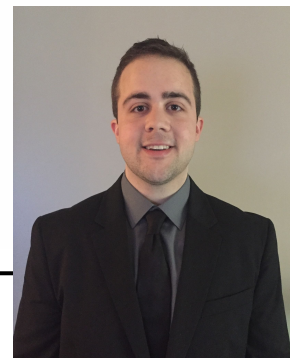

Hardware - Battery Management

- Using a 3S and 25A BMS board (HX-3S-FL25A) at \$5 a board
- Monitors all of the parallel groups in the battery pack and disconnect it from the input power source when fully charged
- Balances the cells voltages equally
- Overvoltage range: $4.25\sim 4.35V \pm 0.05V$
- Over-discharge voltage range: $2.3\sim 3.0V \pm 0.05V$
- Maximum operating current: $0\sim 25A$
- Working temperature: $-40^{\circ}C \sim +50^{\circ}C$

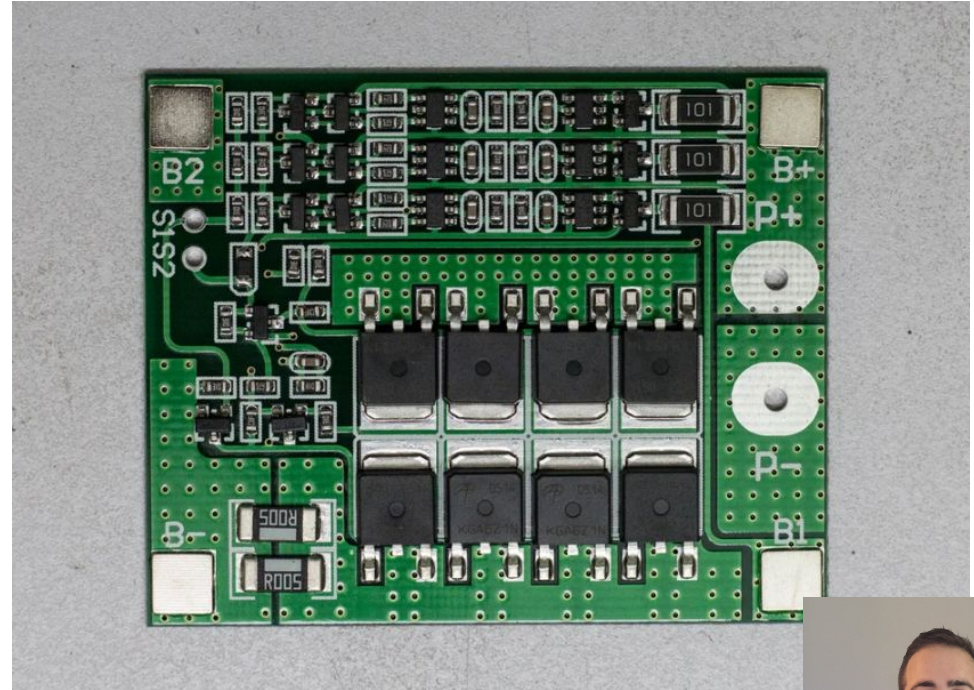

Hardware - BMS Components

Wiring Diagram:

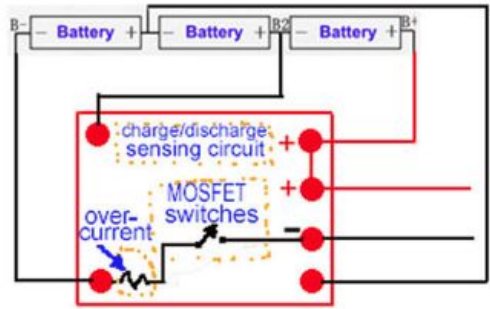
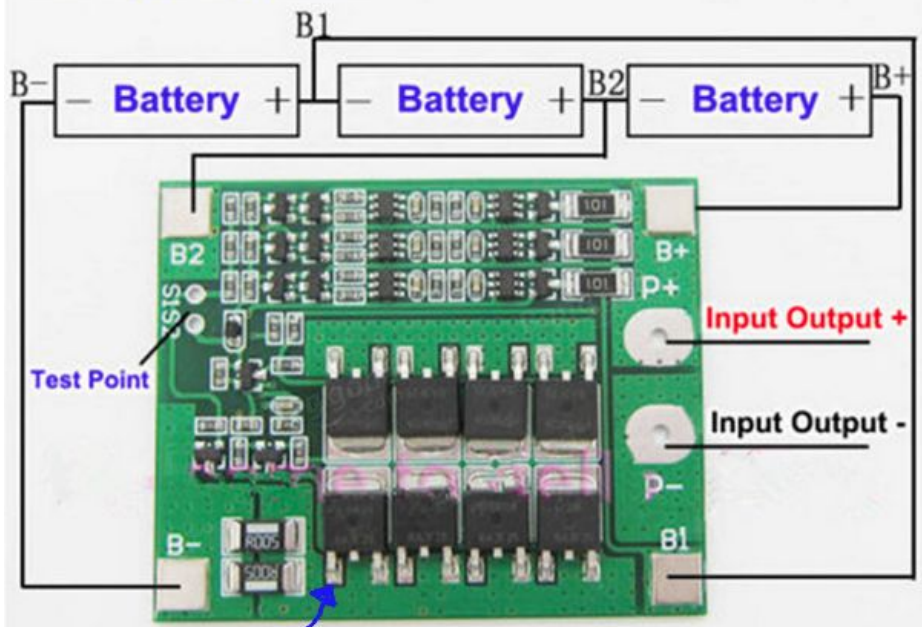

B+ connected to P+

B- connected to P- through MOSFET switches

GATE

P+: Input Output +
P- : Input Output -



BMS Calculations

<u>Efficiency</u>	<u>Number of 18650 batteries in parallel</u>	<u>Resulting Amp Hour Battery Bank</u>	<u>Amp Hour battery Bank / draw from POE+</u>	<u>Hours Provided</u>
100%	5 x 3400mAh	17Ah	17000mAh/ 2400mA	7.08 Hours
	6 x 3400mAh	20.4Ah	20400mAh/ 2400mA	8.5 Hours
	7 x 3400mAh	23.8Ah	23800mAh/ 2400mA	9.916 Hours
	8 x 3400mAh	27.2Ah	27200mAh/ 2400mA	11.33 Hours
80%	5 x 3400mAh	17Ah	17000mAh/ 2880mA	5.902 Hours
	6 x 3400mAh	20.4Ah	20400mAh/ 2880mA	7.08 Hours
	7 x 3400mAh	23.8Ah	23800mAh/ 2880mA	8.26 Hours
	8 x 3400mAh	27.2Ah	27200mAh/ 2880mA	9.44 Hours
	9 x 3400mAh	30.6Ah	30600mAh/ 2880mA	10.625 Hours
	10 x 3400mAh	34Ah	34000mAh/ 2880mA	11.81 Hours



Hardware - Testing and Assembly

- The PCB Board is currently being built as a prototype and will be getting tested against multiple camera systems and POE types in the coming days.
- The Alptop PTZ camera has been acquired and will be tested for its quality and overall movement functions before its final mounting in the system.
- Battery components for the PCB injector are being built and will be connected to multimeters and smart charger to make sure the power output and voltage is sufficient enough for our design.

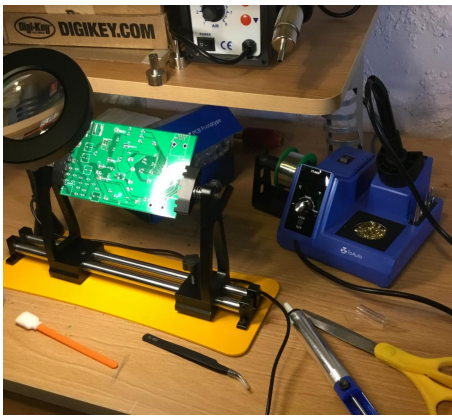

Hardware - Completion Percentage

- Overall Hardware completion

Hardware Component	Completion Percentage	Testing Needed?
PTZ Camera	90% (Product Acquired)	Yes - To check specifications and make sure camera fits quality requirements
PCB Injector	70% (Components Acquired, Beginning to assemble)	Yes - Test multiple cameras
PCB Batteries	50% (Components Acquired)	Yes - Voltage Levels and connection with injector
PC/Laptop	100% (Product Acquired)	No



Work Distribution



	Batteries + BMS	Networking PoE + PCB	Hardware Camera	Storage and Portability	Software Camera	Software Gamepad	Software UI
Mark	X			X			
Steven					X		X
Kevin		X	X				
Santiago						X	X

Budget and Financing

Sponsor: Qwikcut

- Goal is to beat the cost of the current quickbox price which is sitting at \$2,060.
- Should be reasonable price for manufacturing of further systems
- All components and equipment that is not already in use in the previous design and that need to be ordered are to be paid for by our sponsor Todd Denoyer from QwikCut.

<u>Part</u>	<u>Part Description</u>	<u>Quantity</u>	<u>Price (\$USD)</u>
Housing unit	Waterproof containment apparatus	1	30-70
PTZ Camera	Camera to be used in the filming	1	200-600
Tripod	Tripod the system needs to be mounted upon	1	0
Game controller	Controller to control the movement of the PTZ camera	1	30-50
Cable	CAT 5e cable to be connected to the computer and the camera	10m	5-15
Batteries - POE	External batteries to power PCB board or PTZ camera	1-4	10-20
Batteries - Computer	Batteries to operate the laptop - Minimum 4 hour life	1-3	100-150
Computer	Laptop to operate and control the camera from	1	524.99
Poe Injector	Injects power into a ethernet cable	1	50-70
Microphone	Used to pick up audio along with the PTZ camera	1	20-40
SD Card	SD card to download and store the video from the PTZ camera	1-2	10-12
Camera Mount	Custom mount for PTZ to tripod	1	50-150
		Total Price:	\$1,270-\$1,973



Progress Timeline

Week of	June 7th	June 14th	June 21st	June 28th	July 5th	July 12th	July 19th	July 26th
Acquire initial components & equipment	X	X						
Test components	X	X	X					
Develop, Build and test Prototype			X	X				
Adjust Documentation				X	X	X		
Finalize & Fine tune						X	X	X



June 10th



Issues

- Testing and prototyping of our overall design is still being done. Some portions and components selected are subject to change based off our sponsors feedback and desired performance.

Questions